

Ordering number : ENN4384A

Monolithic Digital IC



# LB1841V

## Low-Saturation Current-Controlled Forward/Reverse Motor Driver

### Overview

The LB1841V is a low-saturation current-controlled forward/reverse motor driver with provision for a constant voltage circuit using an external transistor and an output current limiter function. Its design is optimized for use in video camera loading motors.

### Features

- Built-in output current limiter and detector circuit
- Built-in low-saturation voltage forward/reverse bridge circuit:  $V_{O\text{sat}} = 0.40\text{V}$  typ. at 400 mA
- Little current drain in standby mode (up to 0.1  $\mu\text{A}$ )
- Built-in low-saturation constant voltage circuit using an external pnp transistor
- Built-in reference voltage linked to input
- Built-in thermal shutdown circuit
- Low external parts count. Compact SSOP-20 package allows space saving design.

### Package Dimensions

unit: mm

#### 3179A-SSOP20

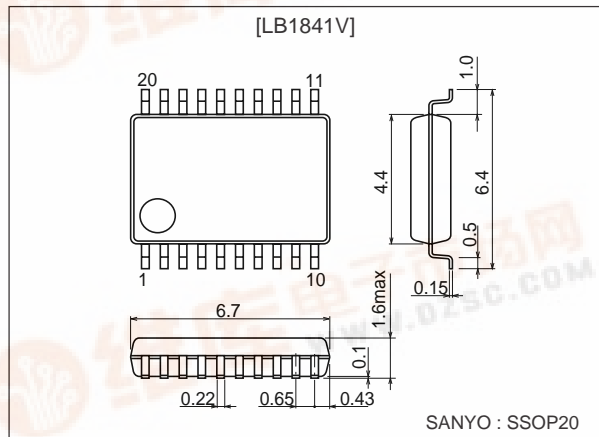

### Specifications

#### Absolute Maximum Ratings at $T_a = 25^\circ\text{C}$

Parameter	Symbol	Conditions	Ratings	Unit
Maximum supply voltage	$V_{CC\text{ max}}$		10.5	V
Maximum output current	$I_{m\text{ max}}$		800	mA
Applied input voltage	$V_{IN}$		-0.3 to +10	V
Allowable power dissipation	$P_{d\text{ max}}$	With substrate ( $50 \times 35 \times 1.6\text{ mm}^3$ )	800	mW
Operating temperature	$T_{op}$		-20 to +80	$^\circ\text{C}$
Storage temperature	$T_{stg}$		-40 to +150	$^\circ\text{C}$

- Any and all SANYO products described or contained herein do not have specifications that can handle applications that require extremely high levels of reliability, such as life-support systems, aircraft's control systems, or other applications whose failure can be reasonably expected to result in serious physical and/or material damage. Consult with your SANYO representative nearest you before using any SANYO products described or contained herein in such applications.
- SANYO assumes no responsibility for equipment failures that result from using products at values that exceed, even momentarily, rated values (such as maximum ratings, operating condition ranges, or other parameters) listed in products specifications of any and all SANYO products described or contained herein.



# LB1841V

## Allowable Operating Ranges at $T_a = 25^\circ\text{C}$

Parameter	Symbol	Conditions	Ratings	Unit
Power supply voltage	$V_{CC}$		3.0 to 9.0	V
Input High voltage	$V_{IH}$		3.0 to 9.0	V
Input Low voltage	$V_{IL}$		-0.3 to 0.7	V
SVR input voltage	$V_{SVR}$		1.0 to $V_{CC}-0.2$	V
LIR input voltage	$V_{LIR}$		0.5 to $V_{CC}-1.0$	V
Output current limiter	$I_{limit}$		50 to 350	mA

## Electrical Characteristics at $T_a = 25^\circ\text{C}$ , $V_{CC} = 7.2\text{V}$

Parameter	Symbol	Conditions	Ratings			Unit
			min	typ	max	
Power supply current	$I_{CC0}$	In standby mode		0.1	10	$\mu\text{A}$
	$I_{CC1}$	Forward/reverse No load		9	13	mA
	$I_{CC2}$	In brake mode		12	18	mA
Output saturation voltage	$V_{sat1}$	$I_O = 200\text{ mA}$ (upper side + lower side)		0.20	0.30	V
	$V_{sat2}$	$I_O = 400\text{ mA}$ (upper side + lower side)		0.40	0.60	V
Reference voltage	$V_{ref}$	$I_{Vref} = 1\text{ mA}$	1.85	2.0	2.15	V
Current limiter characteristics	$I_{limit}$	$V_S - V_M$ resistance = $1\Omega$ at LIR = 2V	165	185	205	mA
Input current	$I_{IN}$	$V_{IN} = 5\text{V}$		90	150	$\mu\text{A}$
PBC drive current	$I_{PBC}$				-10	mA
$V_S$ output voltage	$V_S$			$2.55 \times V_{SVR}$		V
RD saturation voltage	$V_{RDsat}$	$I_O = 1\text{ mA}$			0.3	V

Constant-voltage output  $V_S$  is determined by the equation  $V_S = 2.55 \times V_{SVR}$ .

The input range of  $V_{SVR}$  is 1.0 to 4 V. When  $V_S \geq V_{CC}$ , the output will be saturated.

The output current limiter value is determined according to the following equation ( $R_f$  is a sensing resistor across  $V_S$  and  $V_M$ ).

$$I_{limit} = V_{LIR} / 10 R_f (\text{A})$$

$V_{LIR}$  input range is 0.5 to  $V_{CC} - 1.0$  (V).

## Block Diagram and Sample Application Circuit

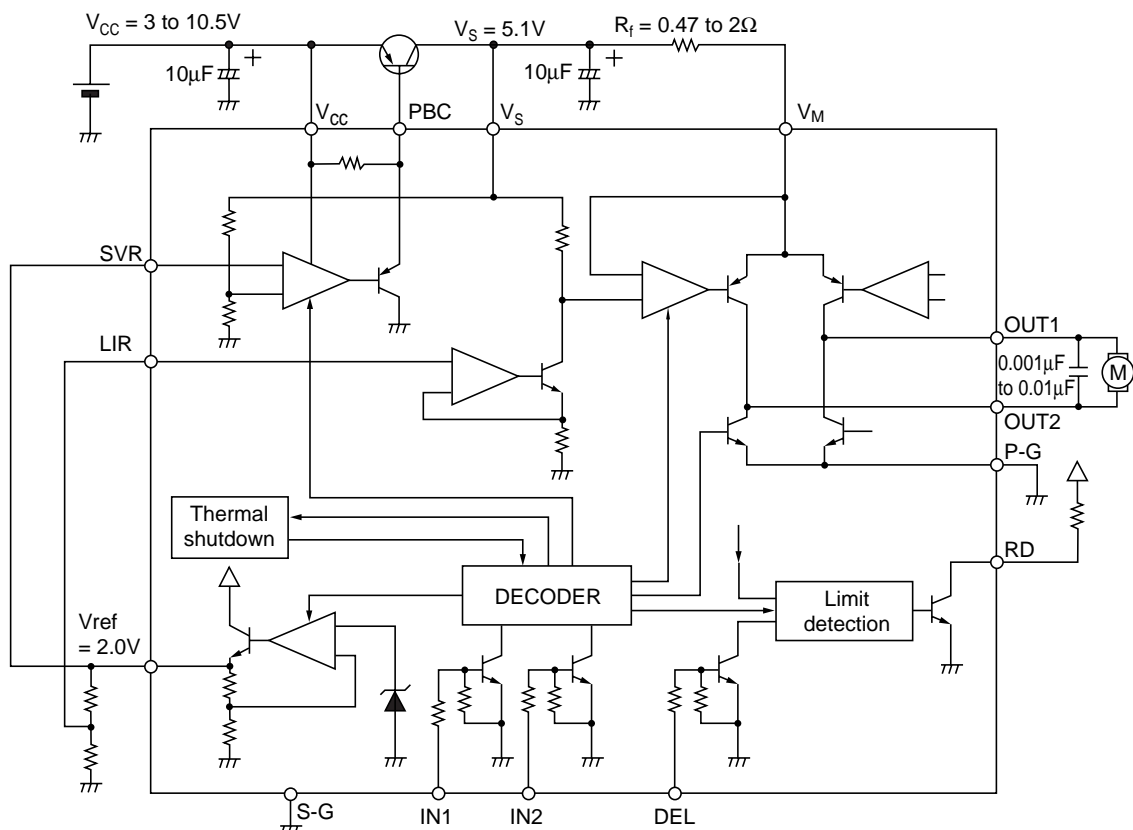

# LB1841V

## Pin Assignment

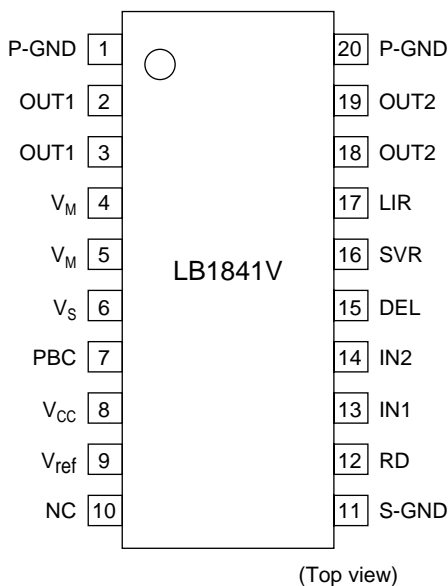

- Note)
- $V_M$  (motor power supply/sensing pin) are both connected.
  - P-GND (motor power supply GND pin) are both connected.
  - S-GND (control power supply ground pin) is connected to microprocessor ground.

## Truth Table

### Bridge and $V_S$ circuits

Input		Output			Mode
IN1	IN2	OUT1	OUT2	$V_S$	
L	L	off	off	off	Standby
H	L	H	L	H	Forward rotation
L	H	L	H	H	Reverse rotation
H	H	L	L	off	Brake

### Output current limiter and detection output

DEL	OUT output	RD
H	limit	L
	Non-limit	off
L	Saturation	off

### Pd max – Ta

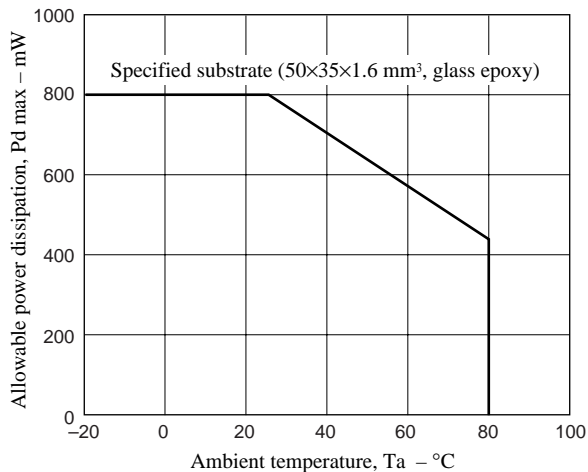

Sample Application Timing Chart

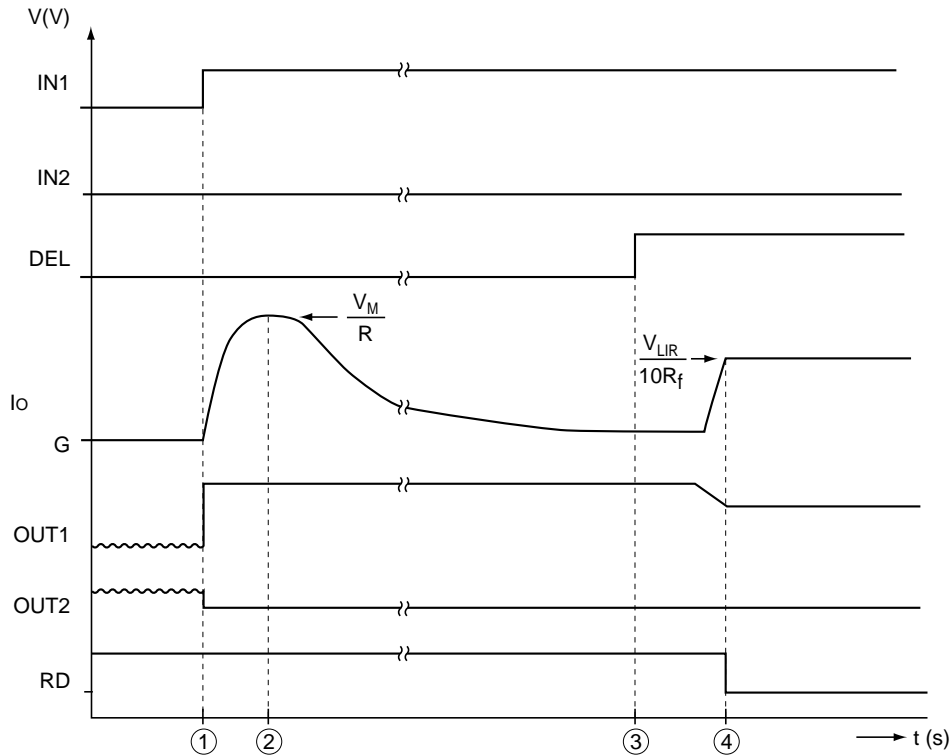

• Sample Application timing chart

- ① Connect DC motor ( $R_L = R\Omega$ ) between OUT1 and OUT2, and input forward signal (IN1 = High, IN2 = Low) with RD pin in pull-up state.  
Because output is saturated during startup, set DEL input to Low.
- ② DC motor starts and startup current ( $I_{ST} = V_M/R$ ) flows through motor.
- ③ DC motor rotates in normal condition. At this point, set DEL input to High.
- ④ When DC motor locks up, motor current  $I_M$  increases. When it reaches  $I_{limit} (=V_{LIR}/(10 R_f))$ , output current limiting circuit operates. At the same time, the set current detection circuit sets RD output to Low.

• Reference voltage Vref

The Vref output is linked to the input. When IN1 or IN2 is High, the reference voltage is output.

• Output current limiter circuitry

The circuit configuration is as shown in the separate diagram.

The output set current is determined by the reference voltage  $V_{LIR}$  applied to the LIR pin. When  $V_{LIR}$  is applied, 1/10 of the voltage occurs across  $R_S$  in the diagram. This voltage is input to the + side of the voltage setting amplifier.

The motor current  $I_M$  generates a voltage ( $I_M \times R_f$ ) across the external resistor  $R_f$ . This voltage is input to the - side of the amplifier. The differential amplifier operates so as to make the two inputs equal, then the output transistor is driven.

The set current is determined by the following equation:

$$I_{limit} = V_{LIR}/(10R_f) [A]$$

## LB1841V

• Set current detection circuit

(1) When DEL = High

When the motor current  $I_M$  is below the set current  $I_{limit}$ , the input voltage ( $I_M \times R_f$ ) at the - side of the current setting amplifier is smaller than the input voltage at the + side (larger vs. ground). The drive current therefore increases and the output pnp transistor saturates. When this condition is detected, a signal is sent to the set current detection circuit and the RD output becomes High.

When the motor current  $I_M$  reaches the set current  $I_{limit}$ , the output pnp transistor is in the controlled state and the RD output becomes Low.

(2) When DEL = Low

When a Low signal is input to the DEL pin, operation of the current setting amplifier is canceled. Therefore as described above, the output transistor saturates and the RD output becomes High.

The above conditions are shown in the table below.

DEL	OUT	RD
H	limit	L
	Non-limit (saturation)	H
L	Saturation	H

### Output Current Limiter and Setting Current Detection Circuits Block Diagram

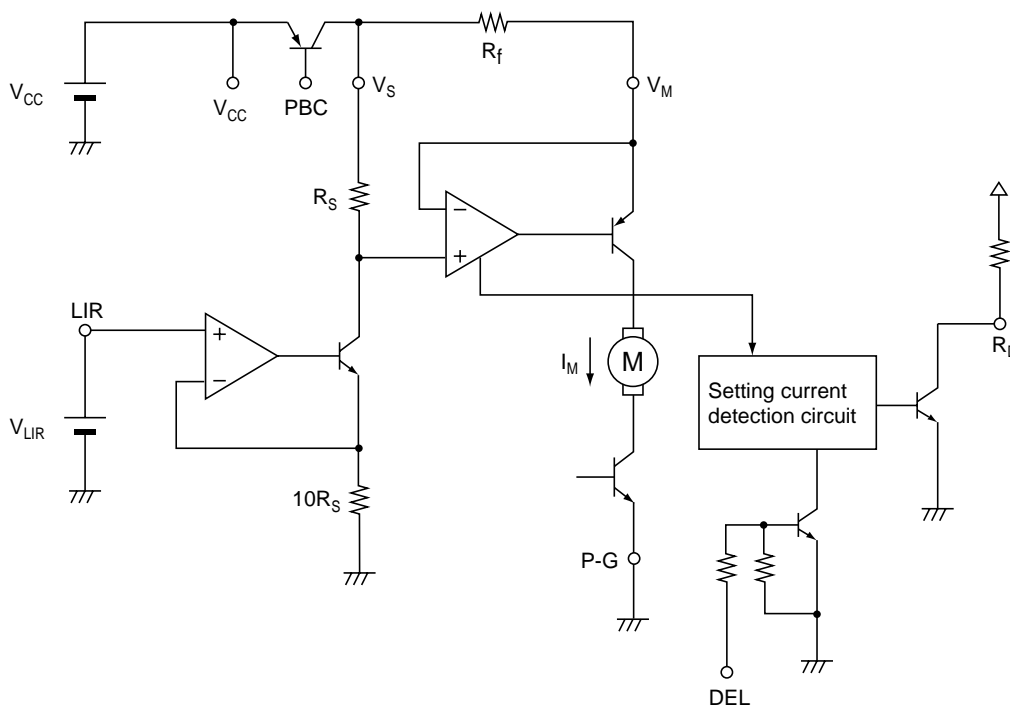

# LB1841V

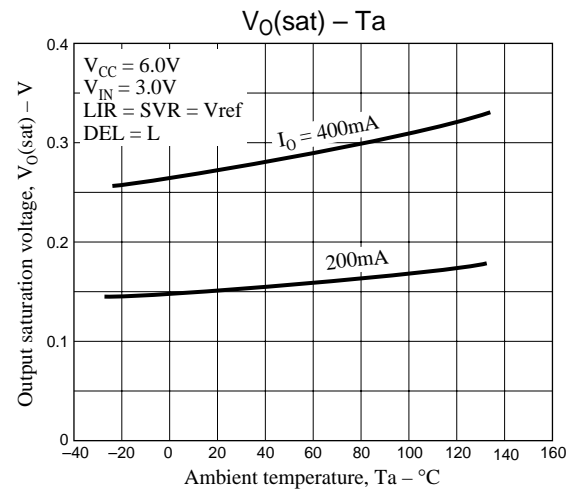
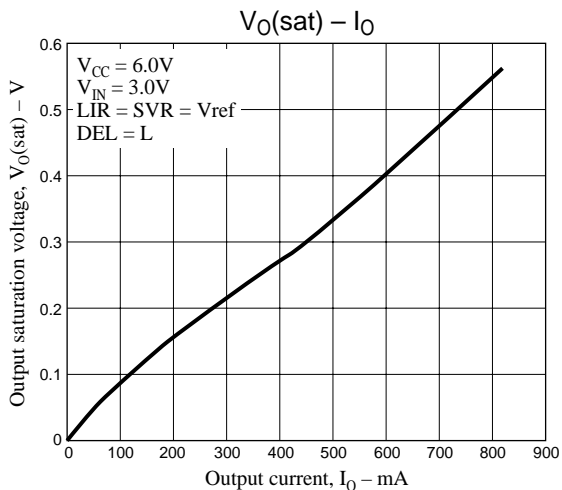
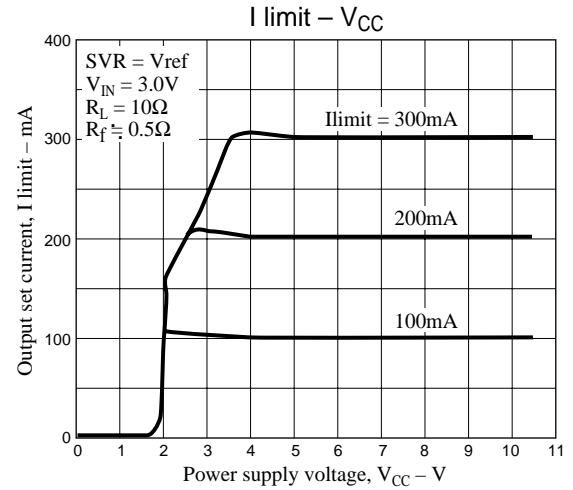
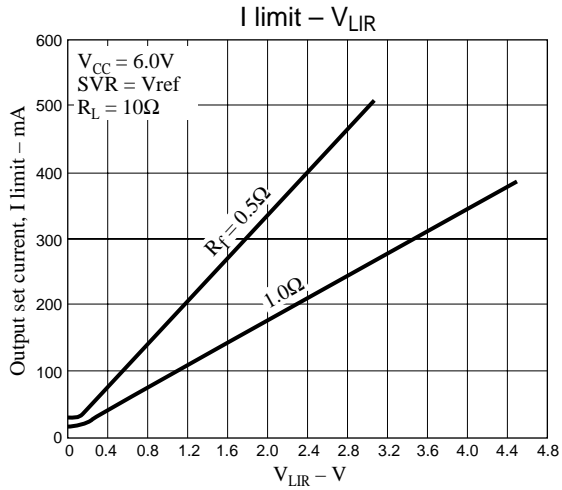
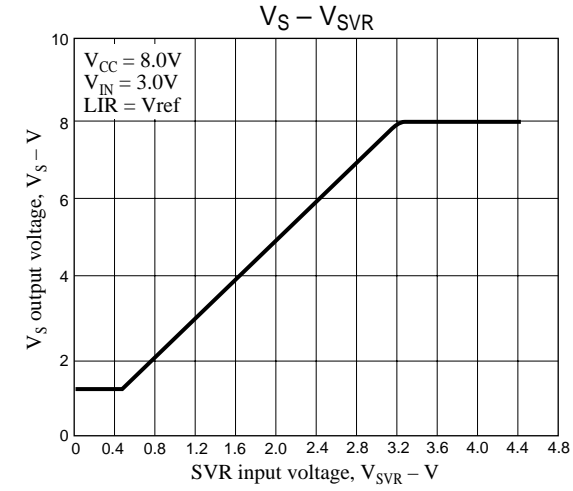
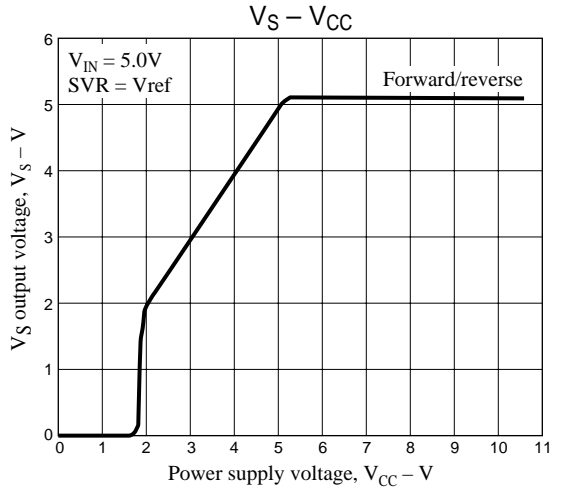
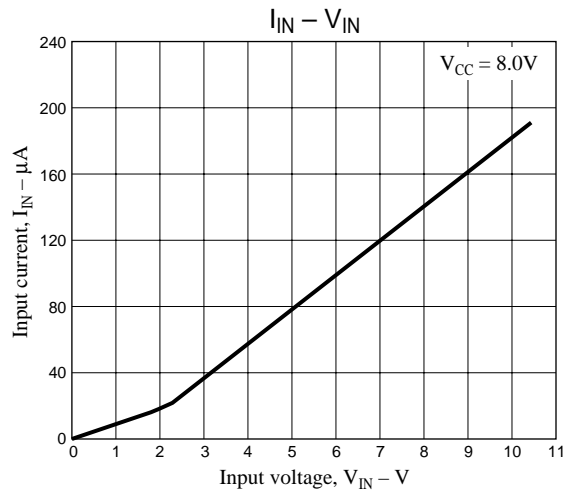
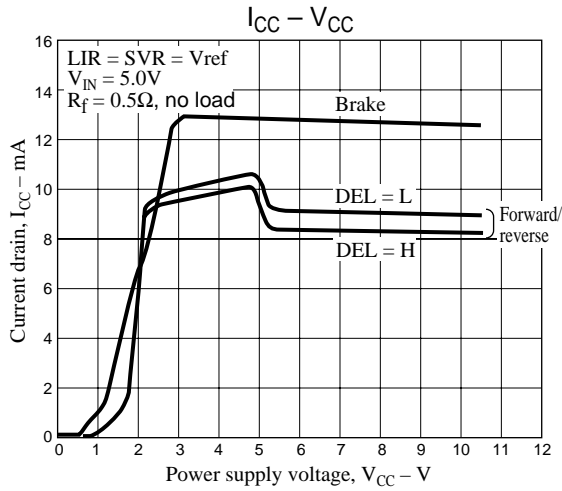

- Specifications of any and all SANYO products described or contained herein stipulate the performance, characteristics, and functions of the described products in the independent state, and are not guarantees of the performance, characteristics, and functions of the described products as mounted in the customer's products or equipment. To verify symptoms and states that cannot be evaluated in an independent device, the customer should always evaluate and test devices mounted in the customer's products or equipment.
- SANYO Electric Co., Ltd. strives to supply high-quality high-reliability products. However, any and all semiconductor products fail with some probability. It is possible that these probabilistic failures could give rise to accidents or events that could endanger human lives, that could give rise to smoke or fire, or that could cause damage to other property. When designing equipment, adopt safety measures so that these kinds of accidents or events cannot occur. Such measures include but are not limited to protective circuits and error prevention circuits for safe design, redundant design, and structural design.
- In the event that any or all SANYO products(including technical data,services) described or contained herein are controlled under any of applicable local export control laws and regulations, such products must not be exported without obtaining the export license from the authorities concerned in accordance with the above law.
- No part of this publication may be reproduced or transmitted in any form or by any means, electronic or mechanical, including photocopying and recording, or any information storage or retrieval system, or otherwise, without the prior written permission of SANYO Electric Co., Ltd.
- Any and all information described or contained herein are subject to change without notice due to product/technology improvement, etc. When designing equipment, refer to the "Delivery Specification" for the SANYO product that you intend to use.
- Information (including circuit diagrams and circuit parameters) herein is for example only ; it is not guaranteed for volume production. SANYO believes information herein is accurate and reliable, but no guarantees are made or implied regarding its use or any infringements of intellectual property rights or other rights of third parties.