

Ordering number : EN4455B

Monolithic Digital IC



# LB1881M

## Three-Phase Brushless Motor Driver IC

### Overview

The LB1881M is a three-phase brushless motor driver IC designed for use as a camcorder capstan or drum motor driver, or as a digital audio tape player/recorder motor driver.

### Features

- 120° voltage linear system
- Appropriate for portable applications, since the LB1881M reduces system power requirements by using motor voltage control for speed control.
- Built-in torque ripple compensation circuit
- Small external capacitances due to the adoption of a soft switching technique (chip capacitor).
- Built-in thermal shutdown circuit
- Built-in FG amplifier

### Package Dimensions

unit: mm

#### 3073A-MFP30S

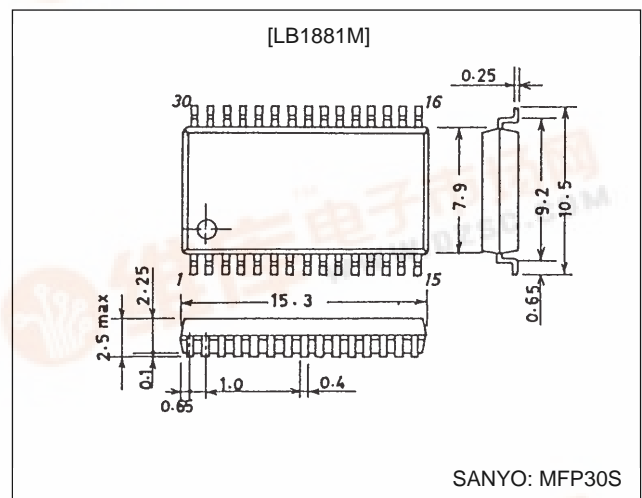

### Specifications

#### Absolute Maximum Ratings at Ta = 25°C

Parameter	Symbol	Conditions	Ratings	Unit
Supply voltage	V <sub>CC1</sub> max		7	V
	V <sub>CC2</sub> max		12	V
	V <sub>S</sub> max		V <sub>CC2</sub>	V
Output applied voltage	V <sub>O</sub> max		V <sub>S</sub> + 2	V
Input applied voltage	V <sub>I</sub> max	All input pins	V <sub>CC1</sub>	V
Output current	I <sub>O</sub> max		1.0	A
Allowable power dissipation	P <sub>d</sub> max		1.0	W
Operating temperature	T <sub>opr</sub>		-20 to +75	°C
Storage temperature	T <sub>stg</sub>		-55 to +150	°C

#### Allowable Operating Ranges at Ta = 25°C

Parameter	Symbol	Conditions	Ratings	Unit
Supply voltage	V <sub>CC1</sub>	V <sub>CC1</sub> ≤ V <sub>CC2</sub>	4.0 to 6.0	V
	V <sub>CC2</sub>		4 to 10	V
	V <sub>S</sub>		Up to V <sub>CC2</sub>	V



## LB1881M

### Electrical Characteristics at $T_a = 25^\circ\text{C}$ , $V_{CC1} = 5\text{ V}$ , $V_{CC2} = 7\text{ V}$ , $V_S = 3\text{ V}$

Parameter	Symbol	Conditions	Ratings			Unit
			min	typ	max	
Supply current	$I_{CC1}$	$V_{BR} = 5\text{ V}$		3.0	5.0	mA
	$I_{CC2}$	$V_{BR} = 5\text{ V}$		6.5	10.0	mA
	$I_S$	$V_{BR} = 5\text{ V}$ , $R_L = \infty$			5.0	mA
Output quiescent current	$I_{CCOQ}$	$V_{STBY} = 0\text{ V}$			100	$\mu\text{A}$
	$I_{SOQ}$	$V_{STBY} = 0\text{ V}$ , $R_L = \infty$			150	$\mu\text{A}$
Output saturation voltage	$V_{O(sat)}$	$I_{OUT} = 0.6\text{ A}$ , sink + source			1.7	V
Output TRS withstand voltage	$V_{O(sus)}$	$I_{OUT} = 20\text{ mA}^{*1}$	12			V
Output quiescent voltage	$V_{OQ}$	$V_{BR} = 5\text{ V}$	1.45	1.55	1.65	V
Hall amplifier input offset voltage	$V_{HOFFSET}$	*1	-5		+5	mV
Hall amplifier common mode input voltage range	$V_{HCOM}$		1.4		2.8	V
Hall I/O voltage gain	$GV_{HO}$	$R_{angle} = 8.2\text{ k}\Omega$	34.0	37.0	40.0	dB
Brake pin high level voltage	$V_{BRH}$		2.0			V
Brake pin low level voltage	$V_{BRL}$				0.8	V
Brake pin input current	$I_{BRIN}$				120	$\mu\text{A}$
Brake pin leakage current	$I_{BRLEAK}$				-30	$\mu\text{A}$
FRC pin high level voltage	$V_{FRCH}$		2.8			V
FRC pin low level voltage	$V_{FRCL}$				1.2	V
FRC pin input current	$I_{FRCIN}$				100	$\mu\text{A}$
FRC pin leakage current	$I_{FRCLEAK}$				-30	$\mu\text{A}$
Upper side residual voltage	$V_{XH}$	$I_{OUT} = 100\text{ mA}$ , $V_{CC2} = 6\text{ V}$ , $V_S = 2\text{ V}$	0.285		0.455	V
Lower side residual voltage	$V_{XL}$	$I_{OUT} = 100\text{ mA}$ , $V_{CC2} = 6\text{ V}$ , $V_S = 2\text{ V}$	0.350		0.440	V
Residual voltage inflection point	$V_{S\Delta VX}$	$I_{OUT} = 100\text{ mA}$ , $V_{CC2} = 6\text{ V}^{*1}$		0.9		V
Overlap level	OL	$V_{CC2} = 6\text{ V}$ , $V_S = 3\text{ V}$ , $R_L = 100\ \Omega$ (Y)	60	70	80	%
Overlap vertical difference	$\Delta OL$	$V_{CC2} = 6\text{ V}$ , $V_S = 3\text{ V}$ , $R_L = 100\ \Omega$ (Y)	-10	0	+10	%
Standby on voltage	$V_{STBYL}$	*2	-0.2		+0.8	V
Standby off voltage	$V_{STBYH}$		2		5	V
Standby pin bias current	$I_{STBYIN}$				100	$\mu\text{A}$
Thermal protection circuit operating temperature	$T_{TSD}$	*1	150	180	210	$^\circ\text{C}$
Thermal protection circuit hysteresis	$\Delta T_{TSD}$	*1		15		$^\circ\text{C}$
FG amplifier input offset voltage	$V_{FG\ OFFSET}$		-8		+8	mV
Open loop voltage gain	$GV_{FG}$	$f = 10\text{ kHz}$		43		dB
Source output saturation voltage	$V_{FG\ OU}$	$I_O = -2\text{ mA}$	3.7			V
Sink output saturation voltage	$V_{FG\ OD}$	$I_O = 2\text{ mA}$			1.3	V
Common mode signal exclusion ratio	$G_{HR}$	*1		80		dB
FG amplifier common mode input voltage range	$V_{FG\ CH}$		0		3.5	V
Phase margin	$\phi_M$	*1		20		deg
Schmitt amplifier threshold voltage	$V_{FGS\ SH}$	$V_{FGIN^+} = 2.5\text{ V}$ , when $V_{FGOUT2}$ goes from high to low	2.45	2.50	2.55	V
Schmitt amplifier hysteresis width	$V_{FGS\ HIS}$	$V_{FGIN^+} = 2.5\text{ V}$	20	40	60	mV

Note: 1. These are target settings, and are not measured. The overlap ratings are taken as test ratings without change.  
2. When the standby pin is open the IC will be in the standby state.

# LB1881M

## Pin Assignment

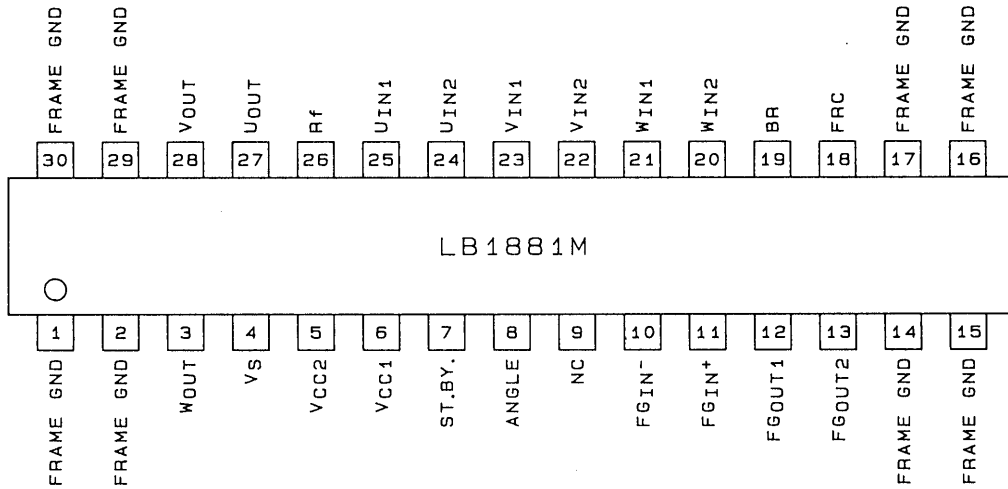

A01379

Top view

## Block Diagram

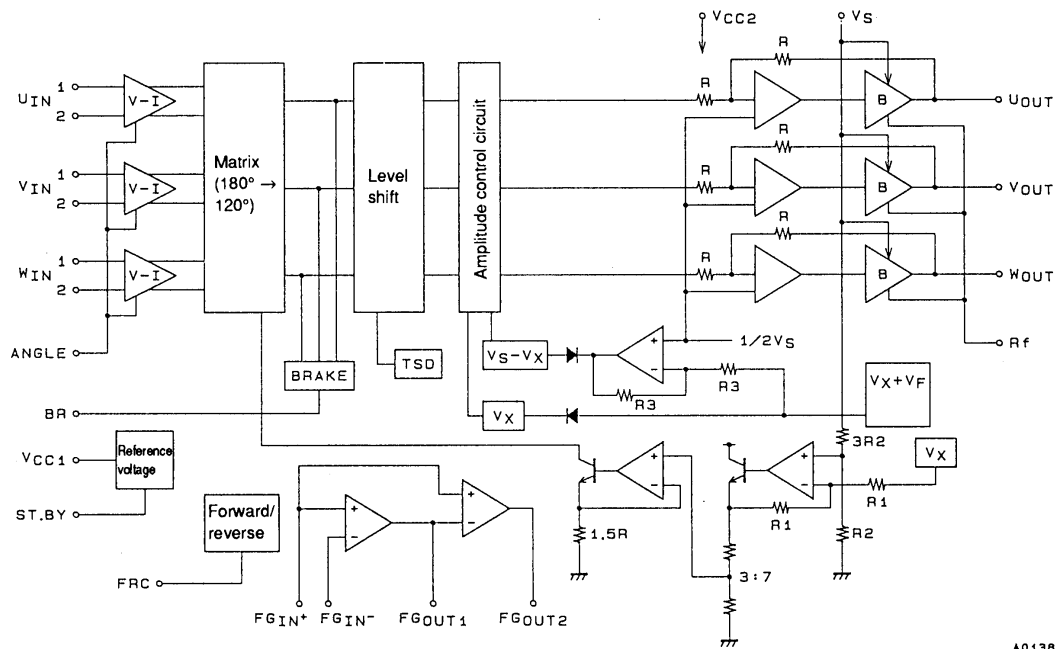

A01389

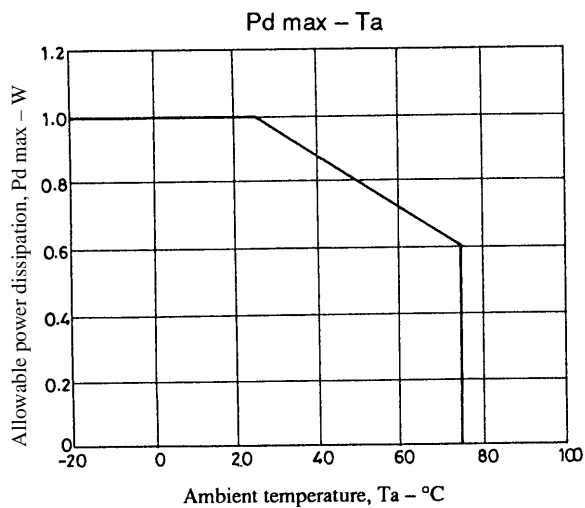

# LB1881M

## Pin Functions

Unit (resistance:  $\Omega$ )

Pin No.	Symbol	Pin voltage	Equivalent circuit	Pin function
4	$V_S$	$\leq V_{CC2}$		Power supply input that determines the output amplitude. It must be set to a voltage equal or lower than $V_{CC2}$ .
5	$V_{CC2}$	4 to 10 V		Power supply for power amplifier systems other than motor drive transistors. Power supply pin that provides voltage for blocks other than control blocks supplied by $V_{CC1}$ .
6	$V_{CC1}$	4 to 6 V		Power supply that provides voltage for the Hall amplifier, the forward/reverse circuit, the FG amplifier, and the thermal shutdown circuit.
7	ST. BY	(H): 2.0 V max (L): 0.8 V min (When $V_{CC1}$ is 5 V)		All circuits can be made inoperative either by connecting this pin to GND, or by leaving it open. In that state the supply current will be approximately 0 $\mu$ A. Hold at 2 V or higher during normal operation.
8	ANGLE			Connect a resistor between this pin and GND. Changing the value of this resistor will change the Hall input-output gain (motor waveform slope).
10 11	$FG_{IN}^-$ $FG_{IN}^+$	0 V min 3.5 V max (When $V_{CC1}$ is 5 V)		FG signal input pin
12	$FG_{OUT1}$			FG amplifier output pin

## LB1881M

Continued from preceding page.

Unit (resistance:  $\Omega$ )

Pin No.	Symbol	Pin voltage	Equivalent circuit	Pin function
13	FG <sub>OUT2</sub>			FG Schmitt amplifier output pin
18	FRC	(H): 2.8 V min (L): 1.2 V max (When V <sub>CC1</sub> is 5 V)		Pin for setting the motor to forward or reverse rotation Low level: Forward rotation (under 1.2 V: when V <sub>CC1</sub> is 5 V) High level: Reverse rotation (over 2.8 V: when V <sub>CC1</sub> is 5 V)
19	BR	(H): 2.0 V min (L): 0.8 V max		Motor brake pin Low level: Motor drive (under 0.8 V) High level: Motor brake (over 2.0 V)
20 21 22 23 24 25	W <sub>IN2</sub> W <sub>IN1</sub> V <sub>IN2</sub> V <sub>IN1</sub> U <sub>IN2</sub> U <sub>IN1</sub>	1.4 V min 2.8 V max (When V <sub>CC1</sub> is 5 V)		W phase Hall element input pins. Logic high is defined to be states where W <sub>IN1</sub> > W <sub>IN2</sub> . V phase Hall element input pins. Logic high is defined to be states where V <sub>IN1</sub> > V <sub>IN2</sub> . U phase Hall element input pins. Logic high is defined to be states where U <sub>IN1</sub> > U <sub>IN2</sub> .
26	R <sub>f</sub>			Output transistor GND
27 28 3	U <sub>OUT</sub> V <sub>OUT</sub> W <sub>OUT</sub>			Output pin
1, 2, 14, 15, 16, 17, 29, 30	FRAME (GND)			GND for all circuits other than output transistors.

