

Monolithic Digital IC

SANYO	No. 4354	LB1890M
	FDD Spindle Motor Driver	

Overview

The LB1890M is a 3-phase DD motor driver IC and is an ideal FDD spindle motor driver for 3.5 inch applications.

Functions and Features

- Three phase total wave linear driver
- Eliminates need for output electrolytic capacitor (however, depending on the motor, this may not apply)
- On-chip digital speed control
- Start/stop circuit
- Current limiter circuit
- On-chip index comparator (single HYS)
- On-chip index delay circuit
- AGC circuit
- Temperature protection circuit

Package Dimensions

unit : mm
3129-MFP36S

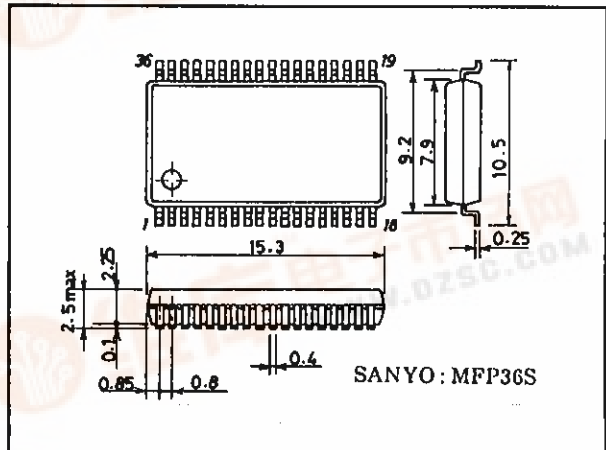

Allowable power dissipation vs. ambient temperature

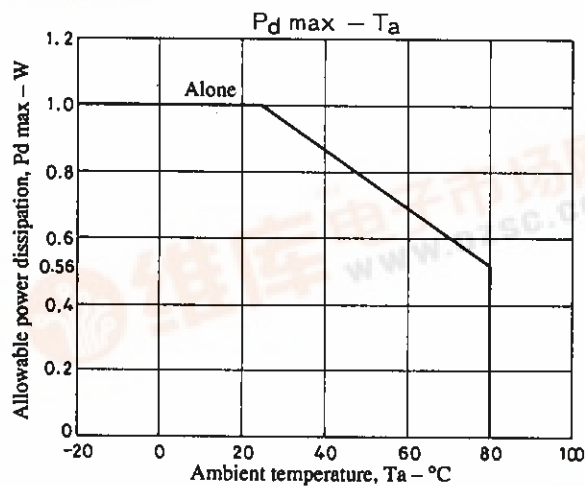

Pin Assignment

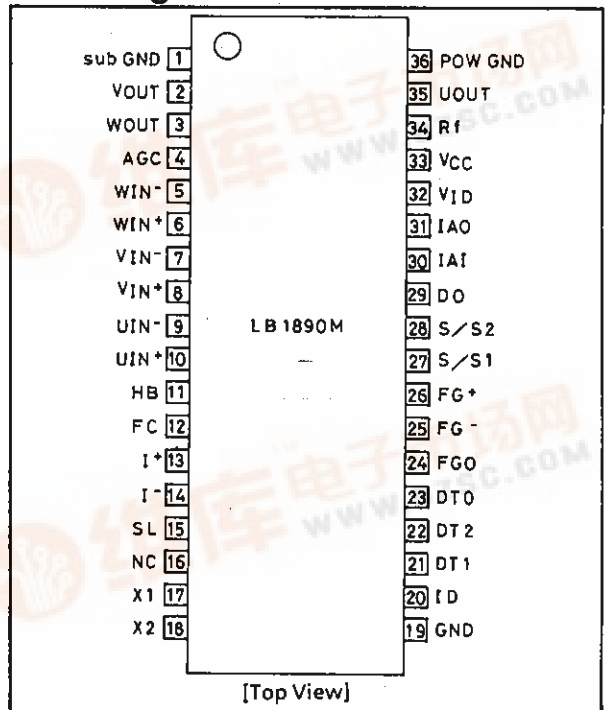

LB1890M

Specifications

Absolute Maximum Ratings at Ta = 25°C

				unit
Maximum supply voltage	V _{CC} max		7.0	V
Maximum output current	I _O max1	≤0.5sec	1.0	A
Steady Maximum output current	I _O max2		0.7	A
Allowable power dissipation	P _d max	IC alone	1	W
Operating temperature	T _{opr}		-20 to +80	°C
Storage temperature range	T _{stg}		-40 to +150	°C

Allowable Operating Conditions at Ta = 25°C

				unit
Supply voltage	V _{CC}		4.2 to 6.5	V

Electrical Characteristics at Ta = 25°C, V_{CC} = 5V

			min	typ	max	unit	note
Current consumption	I _{CCO1}	V _{CC} = 5.0V (Stop)			0.2	mA	
	I _{CC1}	V _{CC} = 5.0V (Steady)		20	30	mA	
Time changeover bias current	I _{SL}				0.4	mA	
Time changeover input voltage 1	V _{SLL}		0		0.8	V	
Time changeover input voltage 2	V _{SLH}		2.0		V _{CC}	V	
S/S1 bias current	I _{S/S1}				0.4	mA	
S/S1 start voltage	V _{S/S1}		2.0		V _{CC}	V	
S/S1 stop voltage	V _{S/S1}		0		0.8	V	
S/S2 bias current	I _{S/S2}				0.1	mA	
S/S2 start voltage	V _{S/S2}		0		0.8	V	
S/S2 stop voltage	V _{S/S2}		2.0		V _{CC}	V	
Hall-effect bias amplifier input current	I _{HB}				20	μA	
In-phase input voltage range	V _H		2.2		V _{CC} - 0.7	V	
Differential input voltage range	V _{dif}		70		250	mVp-p	*2
Input offset voltage	V _{HO}				±1.0	mV	*1
Hall-Effect output voltage	V _H	I _H = 5mA		1.5	1.8	V	
Leak current	I _{HL}	Stop			±10	μA	
Output saturation voltage	V _{SAT1}	I _O = 0.35A, V _{CC} = 4.2V		1.2	1.4	V	
Sink plus source	V _{SAT2}	I _O = 0.70A, V _{CC} = 4.2V		1.5	2.0	V	
Output leak current	I _{OL}				±1.0	mA	
Current limiter	V _{REF1}		0.27	0.30	0.33	V	
Control amplifier voltage gain	G _C			-6		dB	
Voltage gain phase differential	ΔG _C				±1	dB	
Integrated amplifier internal reference voltage	V _{REF2}			V _{CC} /2		V	
Integrated amplifier bias current	I _{IB}				±1	μA	
Integrated output voltage amplitude	V _{I+}	I _I = -0.5 mA with reference of V _{REF2}		0.75		V	
	V _{I-}	I _I = 0.5 mA with reference of V _{REF2}		-1.4		V	
Gain band width				1000		kHz	*1
FG amplifier input voltage	V _{FG}		5		100	mVp-p	
FG amplifier voltage gain	G _{FG}	Open loop		60		dB	*1
FG amplifier input offset	V _{FG0}				±10	mV	
FG amplifier internal reference voltage	V _{FGB}		2.20	2.50	2.80	V	
Schmitt hysteresis width	ΔV _{SH1}	"H" → "L"		25		mV	*1
	ΔV _{SH2}	"L" → "H"		25		mV	*1
Schmitt input operation level	V _{SH}		1		V _{CC} - 1	V	
Speed disk recount number	N			992			
Disk recount out "L" level voltage	V _{DL}	I _D = -0.5mA			0.3	V	
Disk recount out "H" level voltage	V _{DH}	I _D = 0.5mA		V _{CC} - 0.4		V	
Disk recount out leak current	I _{DI}				±1.0	μA	
Disk recount operation frequency	F _D				1.0	MHz	*1
Oscillation range	F _{OSC}				1.0	MHz	*1
Index bias current	I _{IDB}				±10	μA	
In-phase input voltage range	V _{ID}		1.5		V _{CC} - 0.5	V	
Hysteresis setting current range	I _{IDO}		5	10	15	μA	
Index output "L" level voltage	V _{IDL}	V _{ID} = 5V			0.4	V	
Index output "H" level voltage	V _{IDH}	V _{ID} = 5V	4.5			V	
Break-down voltage	V _{DLDC}	V _{ID} = 5V		2.50		V	
Delay output "L" level voltage	V _{DLL}	V _{ID} = 5V			0.4	V	
Delay output "H" level voltage	V _{DLH}	V _{ID} = 5V	4.5			V	
Excessive heat protected operating temperature	TSD		150	180		°C	*1
Hysteresis width	ΔTSD			40		°C	*1

Note: *1) Marked values (*1) are guaranteed by the design itself and therefore do not require measurement.

*2) When hall-effect input becomes larger, kick-back occurs to the output waveform and for this reason, 200 mVp-p or less is recommended.

LB1890M

Block Diagram

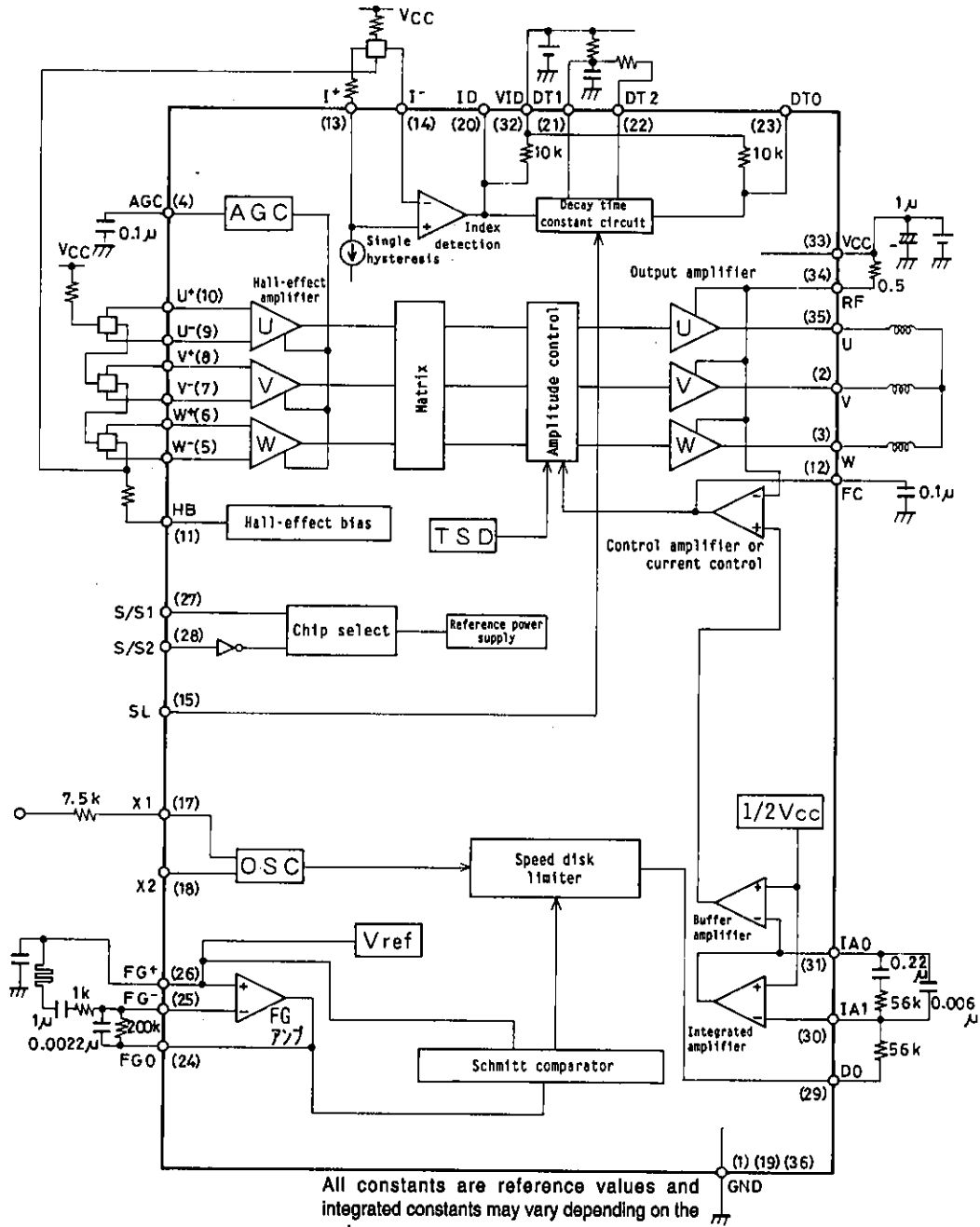

Unit (resistance: Ω , capacitance: F)

LB1890M

Pin Description

Unit (resistance: Ω)

Pin Number	Pin Symbol	Pin Voltage	Equivalent Circuit	Pin Description
5 6 7 8 9 10	W- W+ V- V+ U- U+	2.2V min $V_{CC} - 0.7V$ max		<ul style="list-style-type: none"> W-phase hall-effect input pin. W+ > W- is established when logic is at an "H" level. V-phase hall-effect input pin. V+ > V- is established when logic is at an "H" level. U-phase hall-effect input pin. U+ > U- is established when logic is at an "H" level.
11	HB	1.5V typ ($I_H = 5mA$)		<ul style="list-style-type: none"> Minus pin for hall-effect bias. When stopped, switches open and hall-effect bias severs.
12	FC			<ul style="list-style-type: none"> Frequency characteristics revision pin By installing a capacitor between this pin and GND, close-loop oscillation for the current control system halts.
13 14	I+ I-	1.5V min $V_{CC} - 0.5V$ max		<ul style="list-style-type: none"> Index input pin. When the I+ pin is at an "L" level, I1 operates with the fixed current of $I1 = 10 \mu A$ and when at an "H" level, I1 does not flow. Hysteresis width is determined by the resistor attached externally to the I+ pin.
15	SL	"L": 0.8V max "H": 2.0V min		<ul style="list-style-type: none"> Time changeover pin. 1 : 1.2 "L" level : "H" level
17	X1			<ul style="list-style-type: none"> Reference clock generating pin.
18	X2			
19	GND			<ul style="list-style-type: none"> Ground pin. Grounded as with pins 1 and 36.

Continued on next page.

LB1890M

Continued from preceding page.

Unit (resistance: Ω)

Pin Number	Pin Symbol	Pin Voltage	Equivalent Circuit	Pin Description
20	ID	"L": 0.4V max "H": 4.5V min (When V_{ID} equals 5 V)		<ul style="list-style-type: none"> Index pulse output pin.
21	DT1			<ul style="list-style-type: none"> Pin connecting the external CR for the delay time constant circuit.
22	DT2			<ul style="list-style-type: none"> Break-down current setting pin for the delay time constant circuit.
23	DTO	"L": 0.4V max "H": 4.5V min (When V_{ID} equals 5 V)		<ul style="list-style-type: none"> Index delay pulse output pin.
24	FG0			<ul style="list-style-type: none"> FG amplifier output pin.
25	FG-			<ul style="list-style-type: none"> FG amplifier negative input pin.
26	FG+	2.48V (When V_{ID} equals 5 V)		<ul style="list-style-type: none"> FG amplifier positive input pin. Generates reference voltage within IC.
27	S/S1	"L": 0.8V max "H": 2.0V min		<ul style="list-style-type: none"> Start/stop changeover pin. "H" level active.
28	S/S2	"L": 0.8V max "H": 2.0V min		<ul style="list-style-type: none"> Start/stop changeover pin. "L" level active.

Continued on next page.

LB1890M

Continued from preceding page.

Unit (resistance: Ω).

Pin Number	Pin Symbol	Pin Voltage	Equivalent Circuit	Pin Description
29	DO			<ul style="list-style-type: none"> Speed discriminator output pin.
30	IAI			<ul style="list-style-type: none"> Integrated amplifier input pin.
31	IAO			<ul style="list-style-type: none"> Integrated amplifier output pin.
32	VID			<ul style="list-style-type: none"> Index pulse output and index delay pulse output power supply pin. <p>For applications when V_{CC} equals 5 V, $V_{CC} = V_{ID} = 5$ V.</p>
33	V_{CC}			<ul style="list-style-type: none"> Total power supply voltage pin except for V_{ID}. <p>Voltage must be stable and free of ripple and noise interference.</p>
34	R_f			<ul style="list-style-type: none"> Output current detection pin. <p>By installing an R_f resistor between this pin and V_{CC}, output current is detected as voltage. Voltage detection at this pin activates the current limiter.</p>
35	U_{OUT}			<ul style="list-style-type: none"> U-phase output pin.
36	Pow GND			<ul style="list-style-type: none"> Output transistor ground pin.
1	Sub GND			<ul style="list-style-type: none"> Ground pin. <p>Grounded as with pins 19 and 36.</p>
2	V_{OUT}			<ul style="list-style-type: none"> V-phase output pin.
3	W_{OUT}			<ul style="list-style-type: none"> W-phase output pin.
4	AGC			<ul style="list-style-type: none"> AGC pin. <p>Controls hall-effect amplifier gain in response to hall-effect input frequency.</p>

Truth Table

	Source → Sink	Hall-Effect Input		
		U	V	W
1	V-phase → W-phase	H	H	L
2	V-phase → U-phase	L	H	L
3	W-phase → U-phase	L	H	H
4	W-phase → V-phase	L	L	H
5	U-phase → V-phase	H	L	H
6	U-phase → W-phase	H	L	L

When an "H" level exists for hall-effect input,
 $U^+ > U^-$
 $V^+ > V^-$
 $W^+ > W^-$

Index and Timing Chart

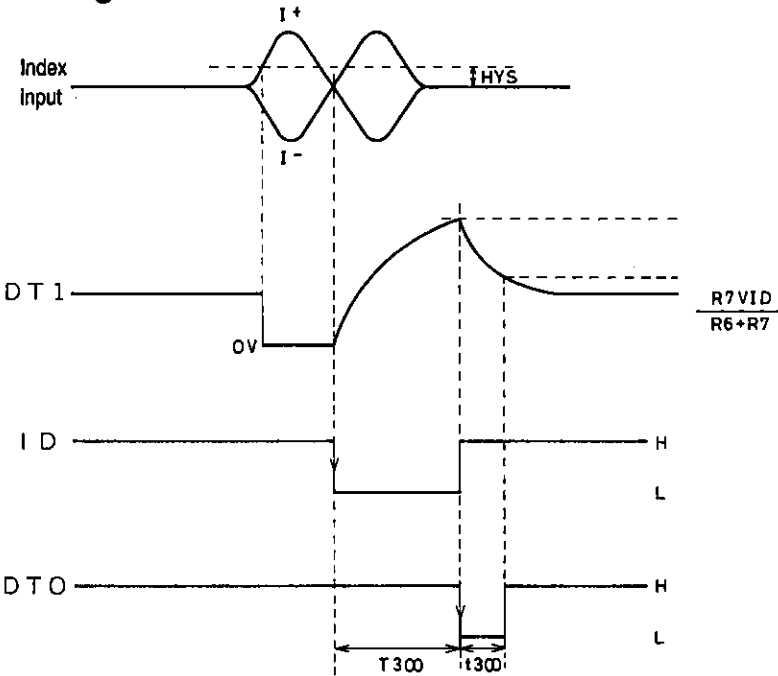

When SL equals an "H" level,

- $T' \approx 0.693CR6$
- $t' \approx \frac{CR6R7}{R6+R7} \left\{ 0.405 + \ln \left(\frac{R6-R7}{R6-2R7} \right) \right\}$

When SL equals an "L" level,

- $T' \approx 0.577CR6$
- $t' \approx \frac{CR6R7}{R6+R7} \left\{ 0.522 + \ln \left(\frac{0.781R6-R7}{R6-2R7} \right) \right\}$

Using only the ID pulse involves shorting DT1 and DT2.

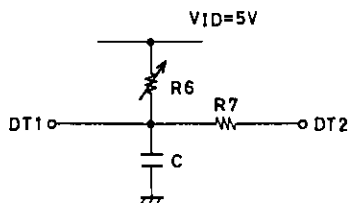

- No products described or contained herein are intended for use in surgical implants, life-support systems, aerospace equipment, nuclear power control systems, vehicles, disaster/crime-prevention equipment and the like, the failure of which may directly or indirectly cause injury, death or property loss.
- Anyone purchasing any products described or contained herein for an above-mentioned use shall:
 - ① Accept full responsibility and indemnify and defend SANYO ELECTRIC CO., LTD., its affiliates, subsidiaries and distributors and all their officers and employees, jointly and severally, against any and all claims and litigation and all damages, cost and expenses associated with such use.
 - ② Not impose any responsibility for any fault or negligence which may be cited in any such claim or litigation on SANYO ELECTRIC CO., LTD., its affiliates, subsidiaries and distributors or any of their officers and employees jointly or severally.
- Information (including circuit diagrams and circuit parameters) herein is for example only; it is not guaranteed for volume production. SANYO believes information herein is accurate and reliable, but no guarantees are made or implied regarding its use or any infringements of intellectual property rights or other rights of third parties.