

Ordering number : EN5877

CMOS IC



LC72720N, 72720NM

Single-Chip RDS Signal-Processing System LSI



Overview

The LC72720N and LC72720NM are single-chip system ICs that implement the signal processing required by the European Broadcasting Union RDS (Radio Data System) standard and by the US NRSC (National Radio System Committee) RDBS (Radio Broadcast Data System) standard. These ICs include band-pass filter, demodulator, synchronization, and error correction circuits as well as data buffer RAM on chip and perform effective error correction using a soft-decision error correction technique.

Functions

- Band-pass filter: Switched capacitor filter (SCF)
- Demodulator: RDS data clock regeneration and demodulated data reliability information
- Synchronization: Block synchronization detection (with variable backward and forward protection conditions)
- Error correction: Soft-decision/hard-decision error correction
- Buffer RAM: Adequate for 24 blocks of data (about 500 ms) and flag memory
- Data I/O: CCB interface (power on reset)

Features

- Error correction capability improved by soft-decision error correction
- The load on the microcontroller can be reduced by storing decoded data in the on-chip data buffer RAM.
- Two synchronization detection circuits provide continuous and stable detection of the synchronization timing.
- Data can be read out starting with the backward-protection block data after a synchronization reset.
- Fully adjustment free
- Operating power-supply voltage: 4.5 to 5.5 V
- Operating temperature: -40 to +85°C
- Packages: DIP24S, MFP24

- CCB is a trademark of SANYO ELECTRIC CO., LTD.
- CCB is SANYO's original bus format and all the bus addresses are controlled by SANYO.

Package Dimensions

unit: mm

3067-DIP24S

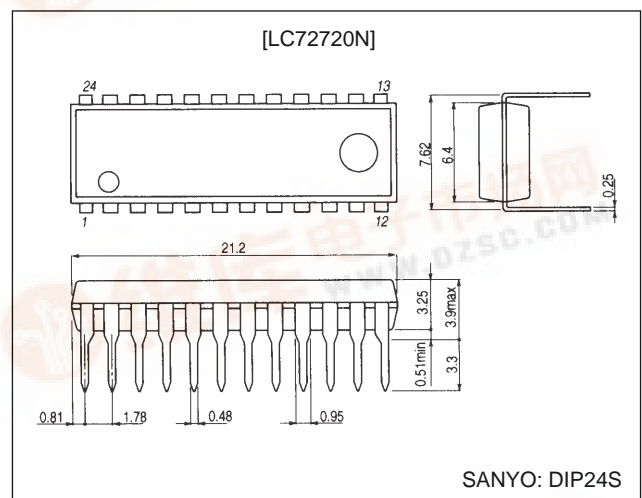

unit: mm

3045B-MFP24

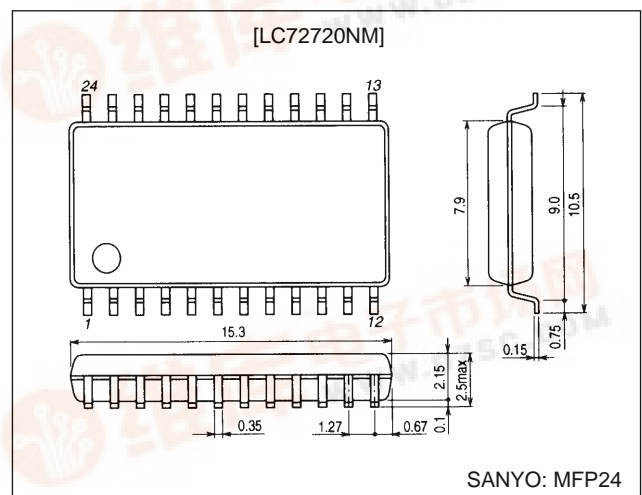

LC72720N, 72720NM

Pin Assignment

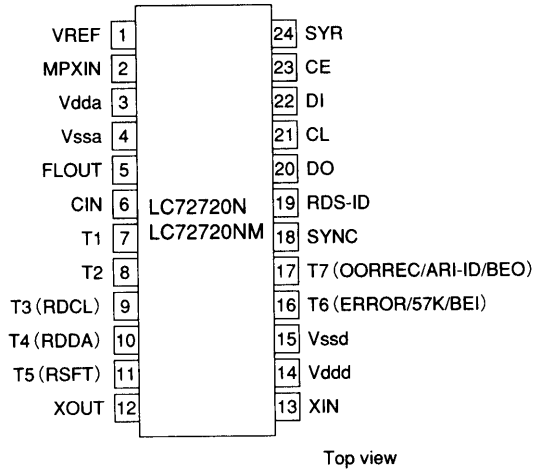

Block Diagram

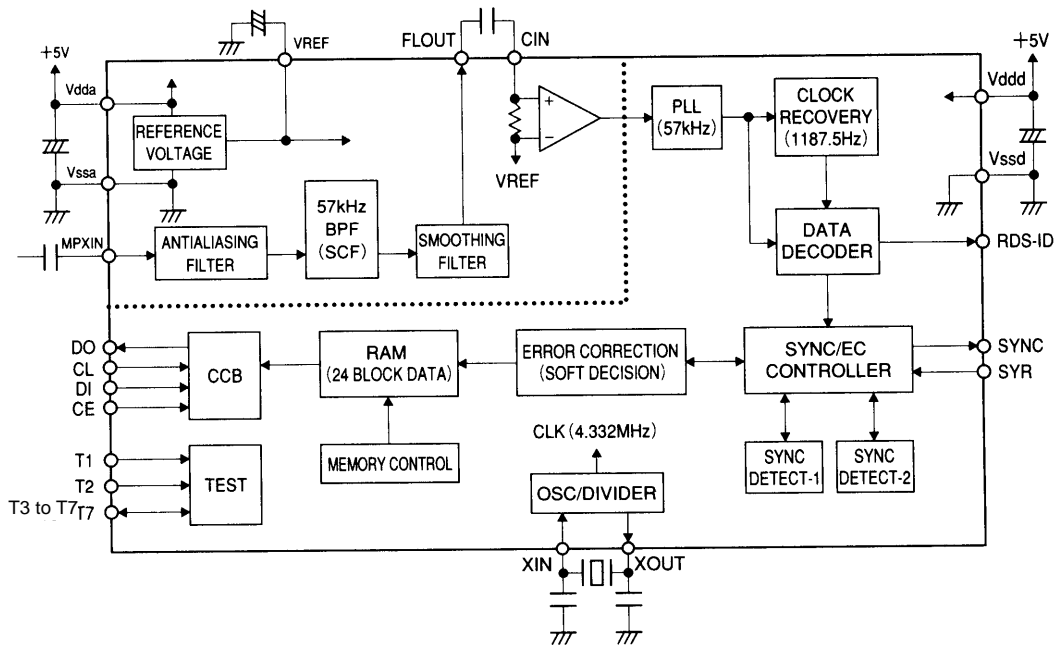

LC72720N, 72720NM

Pin Descriptions

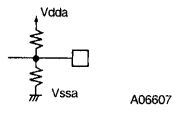
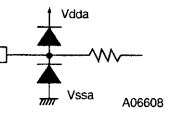
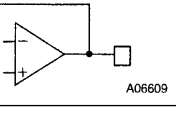
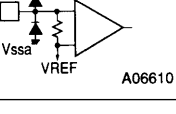
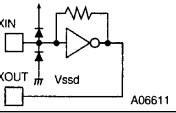
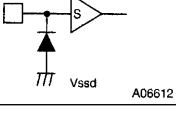
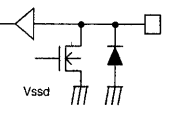
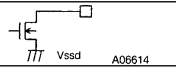
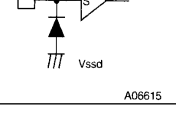
Pin No.	Pin name	Function	I/O	Equivalent circuit
1	VREF	Reference voltage output ($V_{dda}/2$)	Output	 A06607
2	MPXIN	Baseband (multiplexed) signal input	Input	 A06608
5	FLOUT	Subcarrier output (filter output)	Output	 A06609
6	CIN	Subcarrier input (comparator input)	Input	 A06610
3	Vdda	Analog system power supply (+5 V)	—	—
4	Vssa	Analog system ground	—	—
12	XOUT	Crystal oscillator output (4.332/8.664 MHz)	Output	 A06611
13	XIN	Crystal oscillator input (external reference signal input)	Input	
7	T1	Test input (This pin must always be connected to ground.)	Input	 A06612
8	T2	Test input (standby control) 0: Normal operation, 1: Standby state (crystal oscillator stopped)		
9	T3 (RDCL)	Test I/O (RDS clock output)	I/O*	 A06613
10	T4 (RDDA)	Test I/O (RDS data output)		
11	T5 (RSFT)	Test I/O (soft-decision control data output)		
16	T6 (ERROR/57K/BE1)	Test I/O (error status output, regenerated carrier output, error block count output)		
17	T7 (CORREC/ARI-ID/BE0)	Test I/O (Error correction status output, SK detection output, error block count output)		
18	SYNC	Block synchronization detection output	Output	 A06614
19	RDS-ID	RDS detection output		
20	DO	Data output	Input	 A06615
21	CL	Clock input		
22	DI	Data input		
23	CE	Chip enable		
24	SYR	Synchronization and RAM address reset (active high)		
14	Vddd	Digital system power supply (+5 V)	—	—
15	Vssd	Digital system ground	—	—

Note: * Normally function as an output pin. Used as an I/O pin in test mode, which is not available to user applications.

LC72720N, 72720NM

Specifications

Absolute Maximum Ratings at $T_a = 25^\circ\text{C}$, $V_{SSD} = V_{SSA} = 0\text{ V}$

Parameter	Symbol	Conditions	Ratings	Unit	
Maximum supply voltage	$V_{DD\text{ max}}$	Vddd, Vdda ($V_{dda} \leq V_{ddd} + 0.3\text{ V}$)	-0.3 to +7.0	V	
Maximum input voltage	$V_{IN1\text{ max}}$	CL, DI, CE, SYR, T1, T2, T3, T4, T5, T6, T7, SYNC	-0.3 to +7.0	V	
	$V_{IN2\text{ max}}$	XIN	-0.3 to Vddd +0.3	V	
	$V_{IN3\text{ max}}$	MPXIN, CIN	-0.3 to Vdda +0.3	V	
Maximum output voltage	$V_{O1\text{ max}}$	DO, SYNC, RDS-ID, T3, T4, T5, T6, T7	-0.3 to +7.0	V	
	$V_{O2\text{ max}}$	XOUT	-0.3 to Vddd +0.3	V	
	$V_{O3\text{ max}}$	FLOUT	-0.3 to Vdda +0.3	V	
Maximum output current	$I_{O1\text{ max}}$	DO, T3, T4, T5, T6, T7	6.0	mA	
	$I_{O2\text{ max}}$	XOUT, FLOUT	3.0	mA	
	$I_{O3\text{ max}}$	SYNC, RDS-ID	20.0	mA	
Allowable power dissipation	$P_{d\text{ max}}$	$T_a \leq 85^\circ\text{C}$	DIP24S:	350	mW
			MFP24:	300	mW
Operating temperature	T_{opr}		-40 to +85	$^\circ\text{C}$	
Storage temperature	T_{stg}		-55 to +125	$^\circ\text{C}$	

Note: A capacitor of at least 1000 pF must be inserted between the power supply pins Vdd and Vss.

Allowable Operating Ranges at $T_a = -40$ to $+85^\circ\text{C}$, $V_{SSD} = V_{SSA} = 0\text{ V}$

Parameter	Symbol	Conditions	Ratings			Unit
			min	typ	max	
Supply voltage	V_{DD1}	Vddd, Vdda ($V_{ddd} = V_{dda}$)	4.5	5.0	5.5	V
	V_{DD2}	Vddd: Serial data hold voltage	2.0			V
Input high-level voltage	V_{IH}	CL, DI, CE, SYR, T1, T2	0.7 Vddd		6.5	V
Input low-level voltage	V_{IL}	CL, DI, CE, SYR, T1, T2	0		0.3 Vddd	V
Output voltage	V_O	DO, SYNC, RDS-ID, T3, T4, T5, T6, T7			6.5	V
Input amplitude	V_{IN1}	MPXIN : $f = 57 \pm 2\text{ kHz}$			50	mVrms
	V_{IN2}	MPXIN : 100% modulation composite	100			mVrms
	V_{XIN}	XIN	400		1500	mVrms
Guaranteed crystal oscillator frequencies	Xtal	XIN, XOUT : $C_I \leq 120\ \Omega$ ($X_S = 0$)		4.332		MHz
		XIN, XOUT : $C_I \leq 70\ \Omega$ ($X_S = 1$)		8.664		MHz
Crystal oscillator frequency deviation	TXtal	XIN, XOUT : $f_0 = 4.322\text{ MHz}, 8.664\text{ MHz}$			± 100	ppm
Data setup time	t_{SU}	DI, CL	0.75			μs
Data hold time	t_{HD}	DI, CL	0.75			μs
Clock low-level time	t_{CL}	CL	0.75			μs
Clock high-level time	t_{CH}	CL	0.75			μs
CE wait time	t_{EL}	CE, CL	0.75			μs
CE setup time	t_{ES}	CE, CL	0.75			μs
CE hold time	t_{EH}	CE, CL	0.75			μs
CE high-level time	t_{CE}	CE			20	ms
Data latch change time	t_{LC}				1.15	μs
Data output time	t_{DC}	DO, CL: Differs depending on the value of the pull-up resistor used.			0.46	μs
	t_{DH}	DO, CE: Differs depending on the value of the pull-up resistor used.			0.46	μs

Electrical Characteristics in the allowable operating ranges

Parameter	Symbol	Conditions	Ratings			Unit
			min	typ	max	
Input resistance	Rmpxin	MPXIN-Vssa : $f = 57\text{ kHz}$		23		k Ω
	Rcin	CIN-Vssa : $f = 57\text{ kHz}$		100		k Ω
Internal feedback resistance	Rf	XIN		1.0		M Ω
Center frequency	fc	FLOUT	56.5	57.0	57.5	kHz
-3 dB bandwidth	BW - 3 dB	FLOUT	2.5	3.0	3.5	kHz
Gain	Gain	MPXIN-FLOUT : $f = 57\text{ kHz}$	28	31	34	dB
Stop band attenuation	Att1	FLOUT : $\Delta f = \pm 7\text{ kHz}$	30			dB
	Att2	FLOUT : $f < 45\text{ kHz}, f > 70\text{ kHz}$	40			dB
	Att3	FLOUT : $f < 20\text{ kHz}$	50			dB
Reference voltage output	Vref	VREF : Vdda = 5 V		2.5		V

Continued on next page.

LC72720N, 72720NM

Continued from preceding page.

Parameter	Symbol	Conditions	Ratings			Unit
			min	typ	max	
Hysteresis	V_{HIS}	CL, DI, CE, SYR, T1, T2		0.1 V_{DD}		V
Output low-level voltage	V_{OL1}	DO, T3, T4, T5, T6, T7 : I = 2 mA			0.4	V
	V_{OL2}	SYNC, RDS-ID : I = 8 mA			0.4	V
Input high-level current	I_{IH1}	CL, DI, CE, SYR, T1, T2 : $V_I = 6.5$ V			5.0	μ A
	I_{IH2}	XIN : $V_I = V_{DD}$	2.0		11	μ A
Input low-level current	I_{IL1}	CL, DI, CE, SYR, T1, T2 : $V_I = 0$ V			5.0	μ A
	I_{IL2}	XIN : $V_I = 0$ V	2.0		11	μ A
Output off leakage current	I_{OFF}	DO, SYNC, RDS-ID, T3, T4, T5, T6, T7 : $V_O = 6.5$ V			5.0	μ A
Current drain	I_{DD}	$V_{DD} + V_{DDA}$		12		mA

CCB Output Data Format

- Each block of output data consists of 32 bits (4 bytes), of which 2 bytes are RDS data and 2 bytes are flag data.
- Any number of 32-bit output data blocks can be output consecutively.
- When there is no data that can be read out in the internal memory, the system outputs blocks of all-zero data consecutively.
- If data readout is interrupted, the next read operation starts with the 32-bit data block whose readout was interrupted. However, if only the last bit remains to be read, it will not be possible to reread that whole block.
- The check bits (10 bits) are not output.
- To judge whether or not the data is valid, refer to the error information flags E0 to E2, but the offset word detection flags (OWD) should never be referred to.
- If the first four-bits are not "1010", since the readout data is invalid, readout operation must be halted.

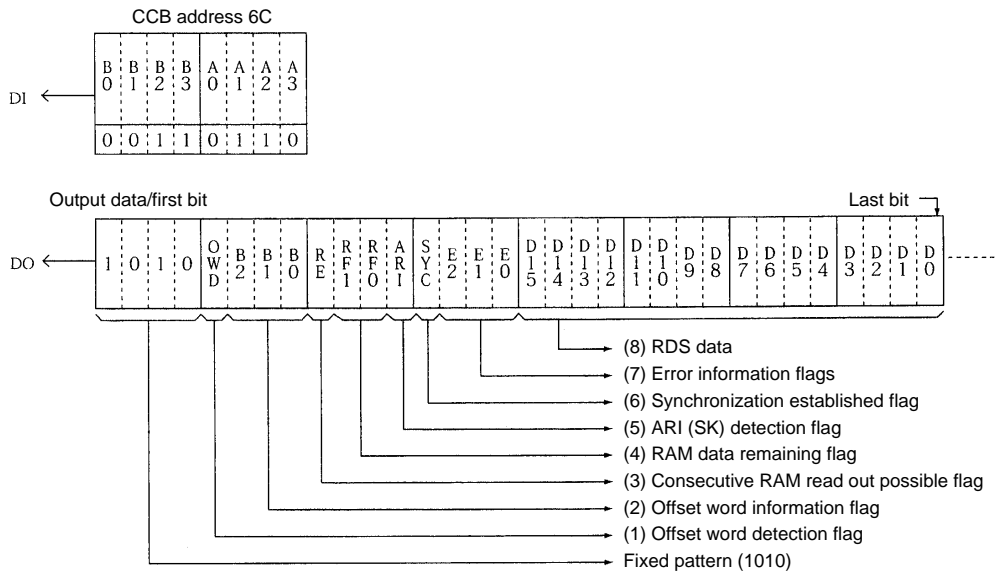

1. Offset word detection flag (1 bit): OWD

A06616

OWD	Offset word detection
1	Detected
0	Not detected (protection function operating)

2. Offset word information flag (3 bits): B0 to B2

B2	B1	B0	Offset word
0	0	0	A
0	0	1	B
0	1	0	C
0	1	1	C'
1	0	0	D
1	0	1	E
1	1	0	Unused
1	1	1	Unused

LC72720N, 72720NM

3. Consecutive RAM readout possible flag (1 bit): RE

RE	RAM data information
1	The next data to be read out is in RAM.
0	This data item is the last item in RAM, and the next data is not present.

4. RAM data remaining flag (2 bits): RF0, RF1

RF1	RF0	Remaining data in RAM (number of blocks)
0	0	1 to 7
0	1	8 to 15
1	0	16 to 23
1	1	24

Note: This value is meaningful only when RE is 1. When RE is 0, there is no data in RAM, even if RF is 00.

If a synchronization reset was applied using SYR, then the backward protection block data that was written to memory is also counted in this value.

5. ARI (SK) detection flag (1 bit): ARI

ARI	SK signal
1	Detected
0	Not detected

6. Synchronization established flag (1 bit): SYC

SYC	Synchronization detection
1	Synchronized
0	Not synchronized

Note: This flag indicates the synchronization state of the circuit at the point where the data block being output was received.

On the other hand, the SYNC pin (pin 18) output indicates the current synchronization state of the circuit.

7. Error information flags (3 bits): E0 to E2

E2	E1	E0	Number of bits corrected
0	0	0	0 (no errors)
0	0	1	1
0	1	0	2
0	1	1	3
1	0	0	4
1	0	1	5
1	1	0	Correction not possible
1	1	1	Unused

Note: If the number of errors exceeds the value of the EC0 to EC2 setting (see the section on the CCB input format), the error information flags will be set to the "Correction not possible" value.

Take the data as invalid when EC0 - EC2 = 011 (correction not possible).

8. RDS data (16 bits): D0 to D15

This data is output with the MSB first and the LSB last.

Caution: When error correction was not possible, the input data is output without change.

CCB Input Data Format

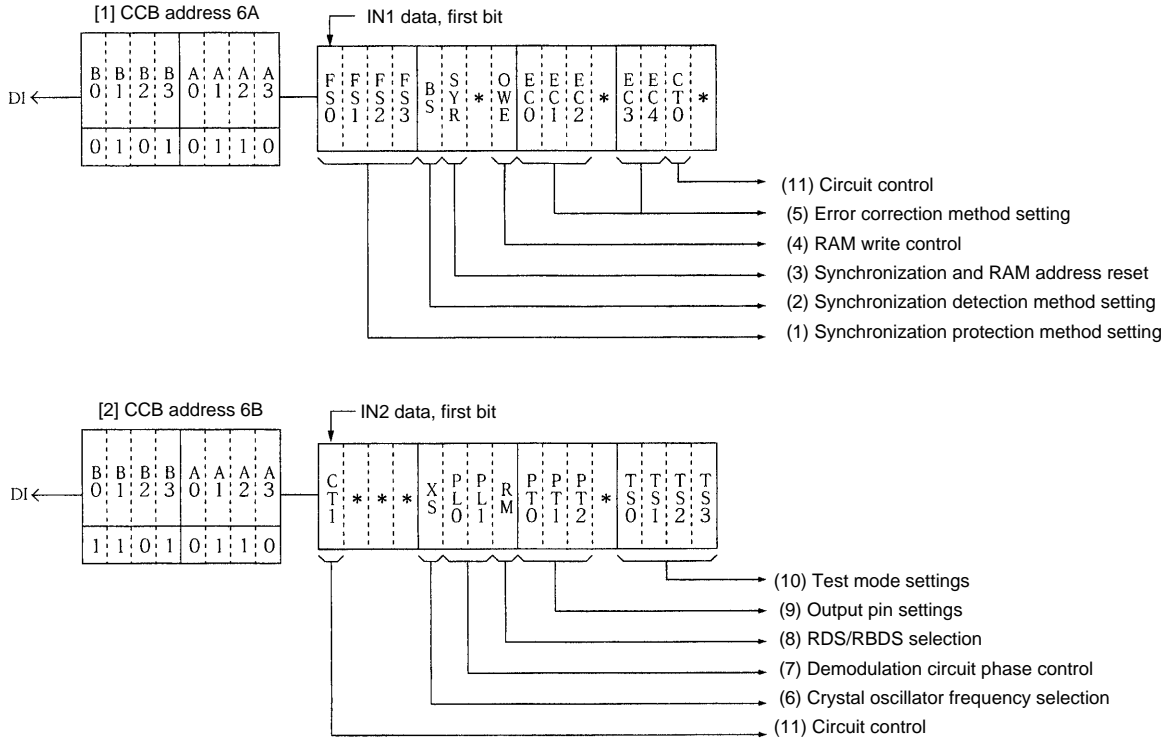

Note: The bits labeled with an asterisk must be set to 0.

A06617

1. Synchronization protection (forward protection) method setting (4 bits): FS0 to FS3

FS3 = 0: If offset words in the correct order could not be detected continuously during the number of blocks specified by FS0 to FS2, take that to be a lost synchronization state.

FS3 = 1: If blocks with uncorrectable errors were received consecutively during the number of blocks specified by FS0 to FS2, take that to be a lost synchronization state.

FS3	FS2	FS1	FS0	Condition for detecting lost synchronization
0	0	0	0	If 3 consecutive blocks matching the FS3 condition are received.
1	0	0	0	If 4 consecutive blocks matching the FS3 condition are received.
0	1	0	0	If 5 consecutive blocks matching the FS3 condition are received.
1	1	0	0	If 6 consecutive blocks matching the FS3 condition are received.
0	0	1	0	If 8 consecutive blocks matching the FS3 condition are received.
1	0	1	0	If 10 consecutive blocks matching the FS3 condition are received.
0	1	1	0	If 12 consecutive blocks matching the FS3 condition are received.
1	1	1	0	If 16 consecutive blocks matching the FS3 condition are received.

Initial value: FS0 = 0, FS1 = 1, FS2 = 0, FS3 = 0

2. Synchronization detection method setting (1 bit): BS

BS	Synchronization detection conditions
0	If, during 3 blocks, 2 blocks of offset words were detected in the correct order.
1	If the offset words were detected in the correct order in 2 consecutive blocks.

Initial value: BS = 0

LC72720N, 72720NM

3. Synchronization and RAM address reset (1 bit): SYR

SYR	Synchronization detection circuit	RAM
0	Normal operation (reset cleared)	Normal write (See the description of the OWE bit.)
1	Forced to the unsynchronized state (synchronization reset)	After the reset is cleared, start writing from the data prior to the establishment of synchronization, i.e. the data in backward protection.

Initial value: SYR = 0

- Note:
- To apply a synchronization reset, set SYR to 1 temporarily using the CCB, and then set it back to 0 again using the CCB. The circuit will start synchronization capture operation at the point SYR is set to 0.
 - The SYR pin (pin 24) also provides an identical reset control operation. Applications can use either method. However, the control method that is not used must be set to 0 at all times. Any pulse with a width of over 250 ns will suffice.
 - A reset must be applied immediately after the reception channel is changed. If a reset is not applied, reception data from the previous channel may remain in memory.
 - Data read out after a synchronization reset is read out starting with the backward protection block data preceding the establishment of synchronization.

4. RAM write control (1 bit): OWE

OWE	RAM write conditions
0	Only data for which synchronization had been established is written.
1	Data for which synchronization has not been established (unsynchronized data) is also written. (However, this applies when SYR = 0.)

Initial value: OWE = 0

5. Error correction method setting (5 bits): EC0 to EC4

E C 0	E C 1	E C 2	Number of bits corrected	E C 3	E C 4	Soft-decision setting
0	0	0	0 (error detection only)	0	0	Mode 0: Hard decision
1	0	0	1 or fewer bits	1	0	Mode 1: Soft decision A
0	1	0	2 or fewer bits	0	1	Mode 2: Soft decision B
1	1	0	3 or fewer bits	1	1	Illegal value
0	0	1	4 or fewer bits			
1	0	1	5 or fewer bits			
0	1	1	Illegal value			
1	1	1	Illegal value			

Initial values: EC0 = 0, EC1 = 1, EC2 = 0, EC3 = 0, EC4 = 1

- Note:
- If soft-decision A or soft-decision B is specified, soft-decision control will be performed even if the number of bits corrected is set to 0 (error detection only). With these settings, data will be output for blocks with no errors.
 - As opposed to soft-decision B, the soft-decision A setting suppresses soft decision error correction.

6. Crystal oscillator frequency selection (1 bit): XS

XS = 0: 4.332 MHz

XS = 1: 8.664 MHz

Initial value: XS = 0

7. Demodulation circuit phase control (2 bits): PL0, PL1

PL0	PL1	Demodulation circuit phase control
0	0/1	<Normal operation> when ARI presence or absence is unclear.
1	0	If the circuit determines that the ARI signal is absent: 90° phase
	1	If the circuit determines that the ARI signal is present: 0° phase

Initial values: PL0 = 0, PL1 = 1

- Note:
- When PL0 is 0 (normal operation), the IC detects the presence or absence of the ARI signal and reproduces the RDS data by automatically controlling the demodulation phase with respect to the reproduced carrier. However, the initial phase following a synchronization reset is set by PL1.
 - If PL0 is set to 1, the demodulation circuit phase is locked according to the PL1 setting at either 90° (PL1 = 0) or 0° (PL1 = 1), allowing RDS data to be reproduced. When ARI is not present, PL1 should be set to 0, since the RDS data is reproduced by detecting at a phase of 90° with respect to the reproduced carrier. When ARI is present, PL1 should be set to 1, since detection is at 0°. In cases where the ARI presence is known in advance, more stable reproduction can be achieved by fixing the demodulation phase in this manner.

LC72720N, 72720NM

8. RDS/RBDS (MMBS) selection (1 bit): RM

RM	RBDS support	Decoding method
0	None	Only RDS data is decoded correctly (Offset word E is not detected.)
1	Provided	RDS and MMBS data is decoded correctly (Offset word E is also detected.)

Initial value: RM = 0

9. Output pin settings (3 bits): PT0 to PT2

These bits control the T3, T4, T5, T6, T7, SYNC, and RDS-ID pins.

Mode	P	P	P	T3	T4	T5	T6			T7			
	T	T	T				RDCL	RDDA	RSFT	ERROR	57K	BE1	CORREC
0	0	0	0	—	—	—	—	—	—	—	—	—	—
1	1	0	0	○	○	○	—	—	—	—	—	—	—
2	0	1	0	○	○	○	—	○	—	—	—	○	—
3	1	1	0	○	○	○	○	—	—	—	○	—	—
4	0	0	1	—	—	—	—	—	○	—	—	—	○
5	1	0	1	●	○	○	—	—	—	—	—	—	—
6	0	1	1	●	○	○	—	●	—	—	—	●	—
7	1	1	1	●	○	○	●	—	—	—	●	—	—

—: Open, ○, ●: Output enabled (● = reverse polarity)

Initial values: PT0 = 1, PT1 = 1, PT2 = 0 (mode 3)

Note: 1. When PT2 is set to 1, the polarity of the T3 (RDCL), T6 (ERROR/57K), T7 (CORREC/ARI-ID) SYNC, and RDS-ID pins changes to active high.

2. The output pins (T3 to T7, SYNC, and RDS-ID) are all open-drain pins, and require external pull-up resistors to output data.

	Pin T3 (RDCL)
PT2 = 0	Data (RDDA and RSFT) changes on this pin's rising edge.
PT2 = 1	Data (RDDA and RSFT) changes on this pin's falling edge.

Mode 2 (PT2 = 0)	Pin T7 (ARI-ID)
No SK	High (1)
SK present	Low (0)

Mode 3 (PT2 = 0)	Pin T6 (ERROR)	Pin T7 (CORREC)
Correction not possible	Low (0)	Low (0)
Errors corrected	High (1)	Low (0)
No errors	High (1)	High (1)

Mode 4	Pin T6 (BE1)	Pin T7 (BE0)
Number of error blocks (B)		
B = 0	Low (0)	Low (0)
1 ≤ B ≤ 20	Low (0)	High (1)
20 < B ≤ 40	High (1)	Low (0)
40 < B ≤ 48	High (1)	High (1)

These pins indicate the number of blocks in a set of 48 blocks that had errors before correction. The output polarity of these pins is fixed at the values listed in the table.

LC72720N, 72720NM

Mode (PT2 = 0)	The SYNC pin
0 to 2	When synchronized: Low (0). When unsynchronized: High (1)
3	When synchronized: Goes high for a fixed period (421 μ s) at the start of a block and then goes low. When unsynchronized: High (1)

Note: The output indicates the synchronization state for the previous block.

When PT2 = 0	The RDS-ID pin
No RDS	High (1)
RDS present	Low (0)

10. Test mode settings (4 bits): TS0 to TS3
 Initial values: TS0 = 0, TS1 = 0, TS2 = 0, TS3 = 0
 (Applications must set these bits to the above values.)

Note: T1 and T2 pins (pins 7 and 8) are related to test mode as follows:

Pin T1	Pin T2	IC operation	Notes
0	0	Normal operating mode	These states are user settable
0	1	Standby mode (crystal oscillator stopped)	
1	0/1	IC test mode	Users cannot use this state

T1 pin must be tied to V_{SS} (0 V).

11. Circuit control (2 bits): CT0 and CT1

	Item	Control
CT0	RSFT control	When set to 1, soft-decision control data (RSFT) is easier to generate.
CT1	RDS-ID detection condition	When set to 1, the RDS-ID detection conditions are made more restrictive.

Initial values: CT0 = 0, CT1 = 0

RDCL/RDDA/RSFT and ERROR/CORREC/SYNC Output Timing

Timing 1 (modes 1 to 3, PT2 = 0)

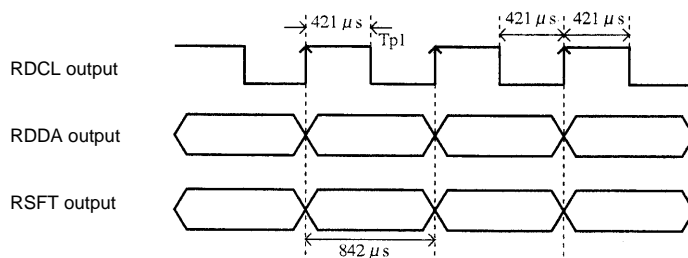

Note: When PT2 = 0, RDDA and RSFT must be acquired on the falling edge of RDCL.

A06618

Timing 2 (mode 3, PT2 = 0)

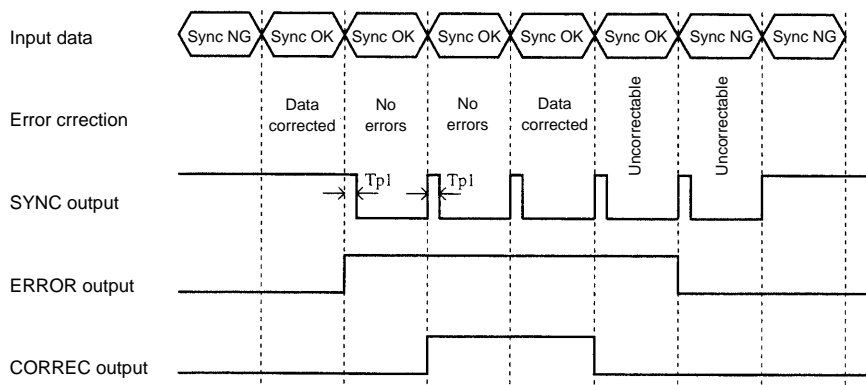

A06619

LC72720N, 72720NM

Serial Data Input and Output Methods

Data is input and output using the CCB (computer control bus), which is the Sanyo audio IC serial bus format. This IC adopts an 8-bit address CCB format.

	I/O mode	Address								Comment
		(LSB)				(MSB)				
		B0	B1	B2	B3	A0	A1	A2	A3	
1	IN1 (6A)	0	1	0	1	0	1	1	0	<ul style="list-style-type: none"> Control data input mode, also referred to as "serial data input" mode. This is a 16-bit data input mode.
2	IN2 (6B)	1	1	0	1	0	1	1	0	<ul style="list-style-type: none"> Control data input mode, also referred to as "serial data input" mode. This is a 16-bit data input mode.
3	OUT (6C)	0	0	1	1	0	1	1	0	<ul style="list-style-type: none"> Data output mode, also referred to as "serial data output" mode. Data output during clock input.

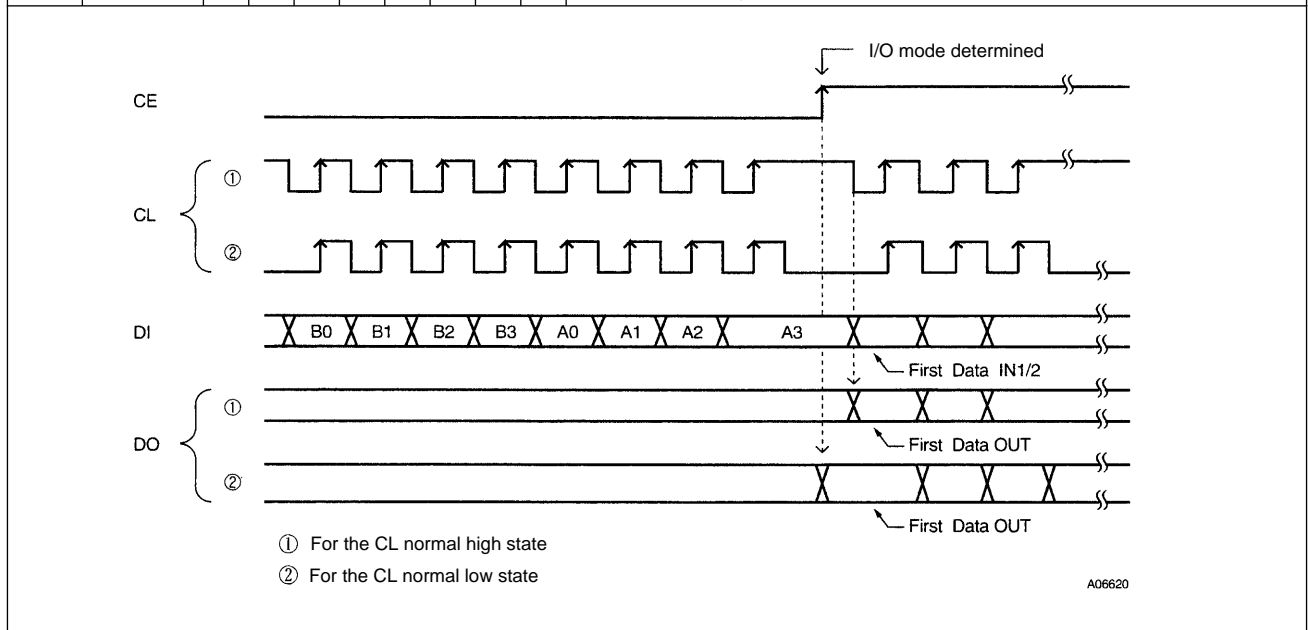

Serial data input (IN1, IN2) $t_{SU}, t_{HD}, t_{EL}, t_{ES}, t_{EH} \geq 0.75 \mu s$ $t_{LC} < 1.15 \mu s$ $t_{CE} < 20 ms$

CL: Normal high

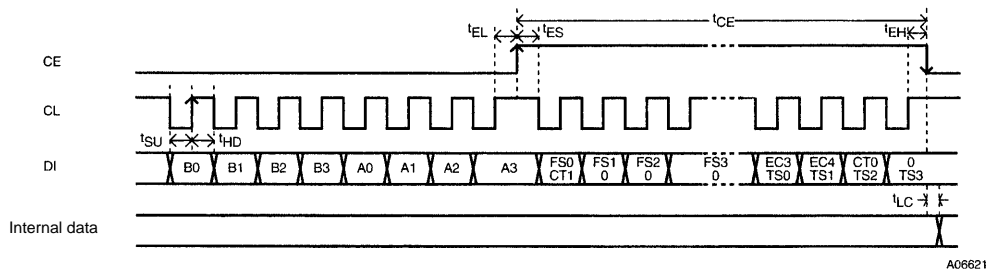

CL: Normal low

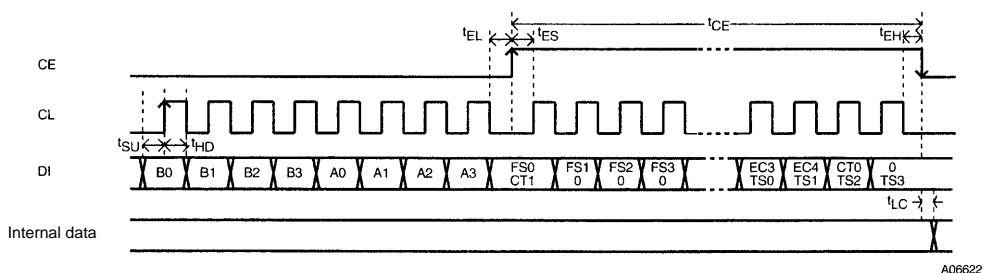

LC72720N, 72720NM

Serial data output (OUT) $t_{SU}, t_{HD}, t_{EL}, t_{ES}, t_{EH} \geq 0.75 \mu s$ $t_{DC}, t_{DH} < 0.46 \mu s$ $t_{CE} < 20 ms$

CL: Normal high

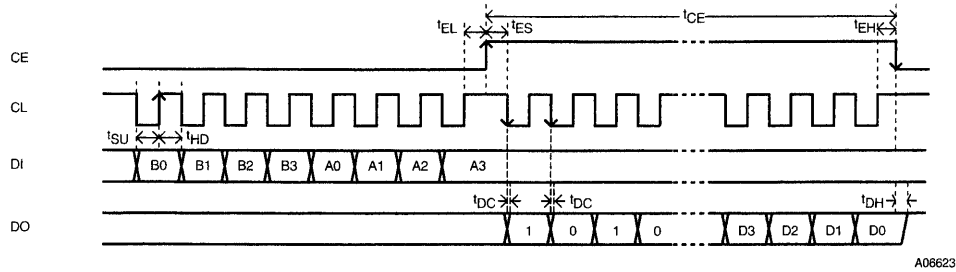

CL: Normal low

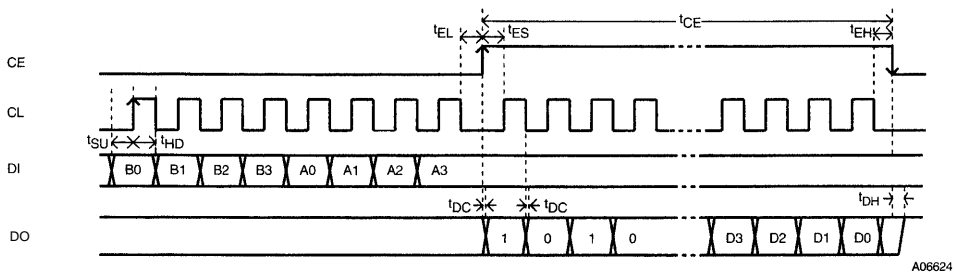

- Notes:
1. Since the DO pin is an n-channel open-drain output, the transition times (t_{DC} , t_{DH}) will differ with the value of the pull-up resistor used.
 2. The CE, CL, DI, and DO pins can be connected to the corresponding pins on other ICs that use the CCB interface. (However, we recommend connecting the DO and CE pins separately if the number of available microcontroller ports allows it.)

Serial data timing

CL: Normal high

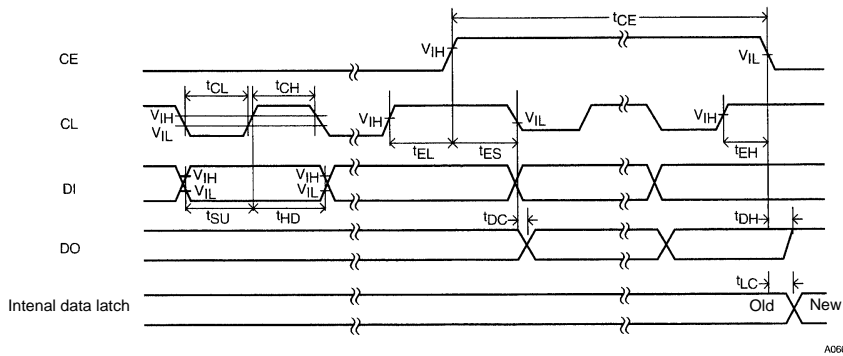

CL: Normal low

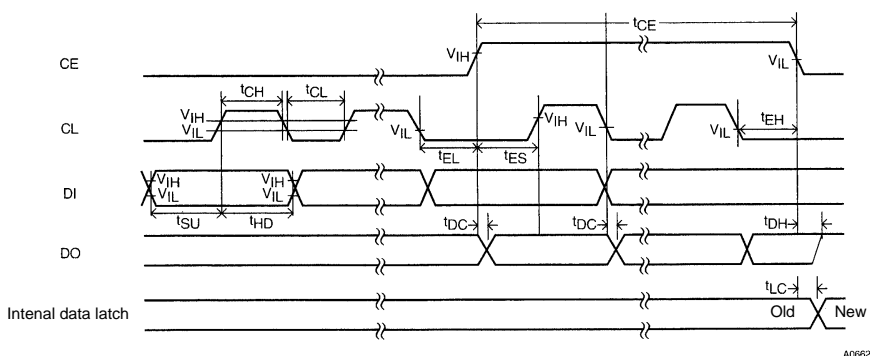

LC72720N, 72720NM

Parameter	Symbol	Conditions	Ratings			Unit
			min	typ	max	
Data setup time	t_{SU}	DI, CL	0.75			μs
Data hold time	t_{HD}	DI, CL	0.75			μs
Clock low-level time	t_{CL}	CL	0.75			μs
Clock high-level time	t_{CH}	CL	0.75			μs
CE wait time	t_{EL}	CE, CL	0.75			μs
CE setup time	t_{ES}	CE, CL	0.75			μs
CE hold time	t_{EH}	CE, CL	0.75			μs
CE high-level time	t_{CE}	CE			20	ms
Data latch transition time	t_{LC}				1.15	μs
Data output time	t_{DC}	DO, CL			0.46	μs
	t_{DH}	DO, CE	Differs with the value of the pull-up resistor used.		0.46	μs

DO pin operation

This IC incorporates a RAM data buffer that can hold up to 24 blocks of data. At the point where one block of data is written to this RAM, the IC issues a read request by switching the DO pin from high to low.

The DO pin always goes high for a fixed period ($T_{do} = 265 \mu s$) after a readout and CE goes low. When all the data in the data buffer has been read out, the DO pin is held in the high state until a new block of data has been written to the RAM. If there is data that has not yet been read remaining in the data buffer, the DO pin goes low after the T_{do} time has elapsed.

After a synchronization reset, the DO pin is held high until synchronization is established. It goes low at the point where the IC synchronizes.

- When the DO pin is high following the $265 \mu s$ period (T_{do}) after data is read out

Here, the buffer is in the empty state, i.e. the state where new data has not been written. After this, when the DO pin goes low, applications are guaranteed to be able to read out that data without it being overwritten by new data if they start a readout operation within 480 ms of DO going low.

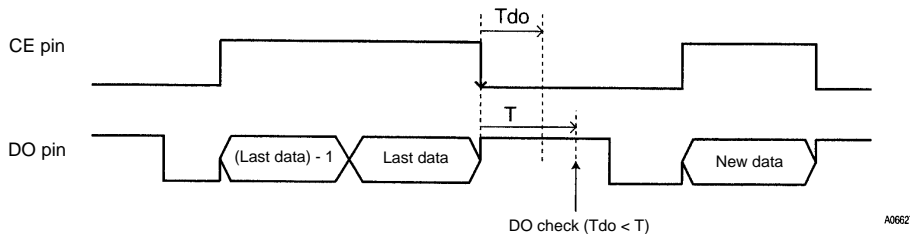

- When the DO pin is low following the $265 \mu s$ period (T_{do}) after data is read out

Here, there is data that has not been read out remaining in the data buffer. In this case, applications are guaranteed to be able to read out that data without it being overwritten by new data if they start a readout operation within 20 ms of DO going low. (Note that this is the worst case condition.)

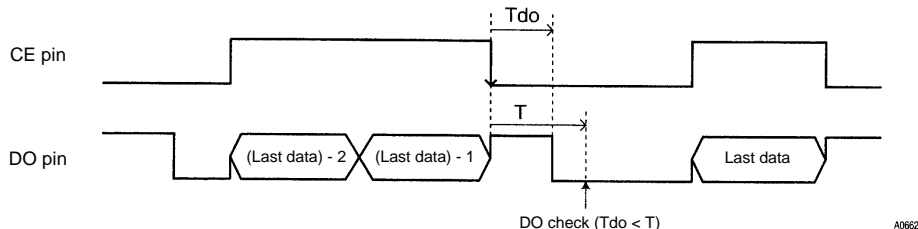

Notes: 1. Although an application can determine whether or not there is data remaining in the buffer by checking the DO level with the above timing, checking the RE and RF flags in the serial data is a preferable method.

2. Applications are not limited to reading out one block of data at a time, but rather can read out multiple blocks of data continuously as described above. When using this method, if an application references the RE and RF flags in the data while reading out data, it can determine the amount of data remaining. However, the length of the period for data readout (the period the CE pin remains high) must be kept under 20 ms.

3. If the DO pin is shared with other ICs that use the CCB interface, the application must identify which IC issued the readout request. One method is to read out data from the LC72720 and either check whether meaningful data has been read (if the LC72720 is not requesting a read, data consisting of all zeros will be read out) or check whether the DO level goes low within the $256 \mu s$ following the completion of the read (if the DO pin goes low, then the request was from another IC).

LC72720N, 72720NM

Sample Application Circuit

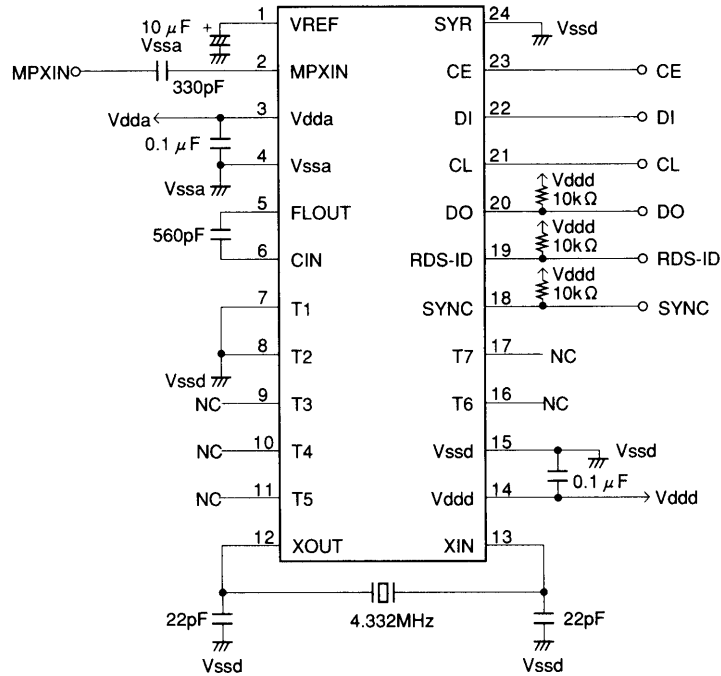

- Notes: 1. Determine the value of the DO pin pull-up resistor based on the required serial data transfer speed.
 2. If the SYR pin is unused, it must be connected to ground.

- No products described or contained herein are intended for use in surgical implants, life-support systems, aerospace equipment, nuclear power control systems, vehicles, disaster/crime-prevention equipment and the like, the failure of which may directly or indirectly cause injury, death or property loss.
- Anyone purchasing any products described or contained herein for an above-mentioned use shall:
 - ① Accept full responsibility and indemnify and defend SANYO ELECTRIC CO., LTD., its affiliates, subsidiaries and distributors and all their officers and employees, jointly and severally, against any and all claims and litigation and all damages, cost and expenses associated with such use:
 - ② Not impose any responsibility for any fault or negligence which may be cited in any such claim or litigation on SANYO ELECTRIC CO., LTD., its affiliates, subsidiaries and distributors or any of their officers and employees jointly or severally.
- Information (including circuit diagrams and circuit parameters) herein is for example only; it is not guaranteed for volume production. SANYO believes information herein is accurate and reliable, but no guarantees are made or implied regarding its use or any infringements of intellectual property rights or other rights of third parties.