	No. * 4914	CMOS LSI
		LC82141
		Facsimile Controller

Preliminary

Overview

The LC82141 is a facsimile controller comprising a CPU, CPU peripheral circuits, image processor, dot change detector for image data compression and expansion, thermal print head interface, I/O ports and other facsimile functions on a single chip. It can be connected to a 9,600bps modem (LC8920, LC89201) or a 14,400bps modem (LC8921) and RAM, ROM, LCD controller and other circuits to form a high performance, low cost facsimile system.

Features

- High-speed 16-bit CPU (65C816), 8MHz cycle
- 16MB program space
- 3-channel DMA controller (2.6MB/s max.)
- 6-channel 16-bit timer
- 4096 pels/line image processing
- 64-gradation half-tone processing (dither method, error diffusion method)
- Shading correction for all pels
- AGC, 8-bit A/D converter
- Soft codec accelerator
- TPH interface (1,2,4 strobe divisions, latchless head)
- Transmit/receive stepping motor interface
- 32 I/O ports
- Single 5V supply
- CMOS process for low-power dissipation

Package Dimensions

unit: mm

3153-QFP160E

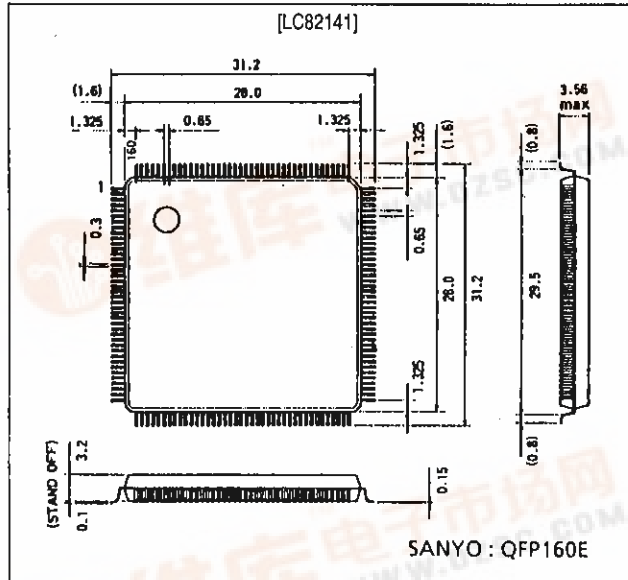

LC82141

Block Diagram

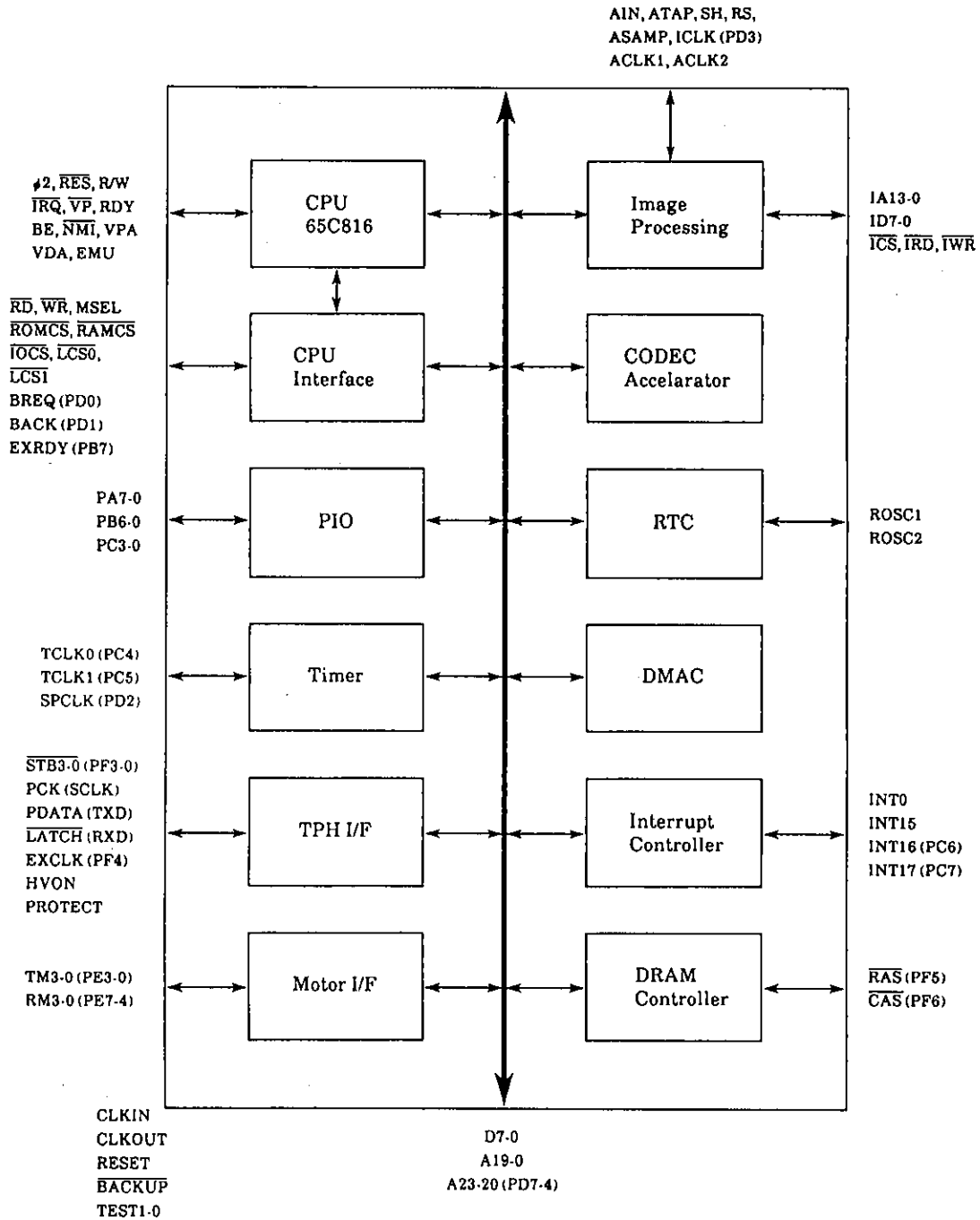

Pin Functions

Number	Name	IO ¹	Description
1	V _{SS}	P	Ground connection pin
2	\overline{RD}	O	Read signal from CPU
3	\overline{WR}	O	Write signal from CPU
4	\overline{ROMCS}	O	Program ROM chip select signal
5	\overline{RAMCS}	O	Work RAM chip select signal

LC82141

Number	Name	I/O ¹	Description
6	$\overline{\text{IOCS}}$	O	External I/O chip select signals
7	$\overline{\text{LCS0}}$	O	
8	$\overline{\text{LCS1}}$	O	
9	MSEL	I	CPU memory space select signal
10	INT0	I	External interrupt request signals
11	INT15	I	
12	D7	B	Data bus
13	D6	B	
14	D5	B	
15	D4	B	
16	D3	B	
17	D2	B	
18	D1	B	
19	D0	B	
20	V _{DD}	P	Supply pin
21	V _{SS}	P	Ground connection pin
22	A23 (PD7)	B	Address bus/General-purpose port D
23	A22 (PD6)	B	
24	A21 (PD5)	B	
25	A20 (PD4)	B	
26	A19	O	Address bus
27	A18	O	
28	A17	O	
29	A16	O	
30	$\phi 2$	O	ICE system clock
31	$\overline{\text{RES}}$	O	ICE reset signal
32	R/W	I	ICE read/write signal
33	$\overline{\text{IRQ}}$	O	ICE interrupt request signal
34	$\overline{\text{VP}}$	I	ICE vector address signal
35	RDY	O	ICE ready signal
36	BE	O	ICE bus enable signal
37	VPA	I	ICE valid program address signal
38	VDA	I	ICE valid data address signal
39	$\overline{\text{NMI}}$	I	Non-maskable interrupt request signal
40	V _{DD}	P	Supply pin
41	V _{SS}	P	Ground connection pin
42	A15	O	Address bus
43	A14	O	
44	A13	O	
45	A12	O	
46	A11	O	
47	A10	O	
48	A9	O	
49	A8	O	

LC82141

Number	Name	I/O ¹	Description
50	PA7	B	General-purpose port A
51	PA6	B	
52	PA5	B	
53	PA4	B	
54	PA3	B	
55	PA2	B	
56	PA1	B	
57	PA0	B	
58	ROSC1	I	RTC crystal oscillator connection pins
59	ROSC2	O	
60	V _{DD}	P	Supply pin
61	V _{SS}	P	Ground connection pin
62	A7	O	Address bus
63	A6	O	
64	A5	O	
65	A4	O	
66	A3	O	
67	A2	O	
68	A1	O	
69	A0	O	
70	EXRDY (PB7)	B	External ready signal/General-purpose port B
71	PB6	B	General-purpose port B
72	PB5	B	
73	PB4	B	
74	PB3	B	
75	PB2	B	
76	PB1	B	
77	PB0	B	
78	CLKIN	I	System clock crystal oscillator connection pins
79	CLKOUT	O	
80	V _{DD}	P	Supply pin
81	V _{SS}	P	Ground connection pin
82	INT17 (PC7)	B	External interrupt request signals/General-purpose port C
83	INT16 (PC6)	B	
84	TCLK1 (PC5)	B	Timer external clock inputs/General-purpose port C
85	TCLK0 (PC4)	B	
86	PC3	B	General-purpose port C
87	PC2	B	
88	PC1	B	
89	PC0	B	
90	RM3 (PE7)	B	Receive motor phase signals/General-purpose port E
91	RM2 (PE6)	B	
92	RM1 (PE5)	B	
93	RM0 (PE4)	B	

LC82141

Number	Name	I/O ¹	Description
94	TM3 (PE3)	B	Transmit motor phase signals/General-purpose port E
95	TM2 (PE2)	B	
96	TM1 (PE1)	B	
97	TM0 (PE0)	B	
98	PDATA (TXD)	O	Thermal head serial output data/Serial I/O transmit data
99	PCK (SCLK)	B	Thermal head data transmission clock/Serial I/O clock
100	V _{DD}	P	Supply pin
101	V _{SS}	P	Ground connection pin
102	LATCH (RXD)	B	Thermal head data latch signal/Serial I/O receive data
103	STB3 (PF3)	B	Thermal head strobe signals/General-purpose port F
104	STB2 (PF2)	B	
105	STB1 (PF1)	B	
106	STB0 (PF0)	B	
107	EXCLK (PF4)	B	Thermal head control external clock/General-purpose port F
108	HVON	O	Head voltage ON/OFF control signal
109	PROTECT	I	Head protection abnormality signal input
110	ID7	B	Image processor memory data bus
111	ID6	B	
112	ID5	B	
113	ID4	B	
114	ID3	B	
115	ID2	B	
116	ID1	B	
117	ID0	B	
118	ACLK1	O	Image sensor transmission clocks
119	ACLK2	O	
120	V _{DD}	P	Supply pin
121	V _{SS}	P	Ground connection pin
122	AVDD	P	Analog supply pin
123	AIN	I	Analog image signal input
124	TEMP	I	Thermistor input
125	ATAP	I	Built-in A/D converter reference voltage
126	AVSS	P	Analog ground connection
127	RESET	I	Reset signal
128	SH	O	Image sensor start pulse
129	RS	O	Image sensor reset pulse
130	ASAMP	O	Built-in A/D converter sampling point monitor signal
131	IR _D	O	Image processor memory read signal
132	I _W R	O	Image processor memory write signal

LC82141

Number	Name	I/O ¹	Description
133	IA13	O	Image processor memory address bus
134	IA12	O	
135	IA11	O	
136	IA10	O	
137	IA9	O	
138	IA8	O	
139	IA7	O	
140	V _{DD}	P	Supply pin
141	V _{SS}	P	Ground connection pin
142	$\overline{\text{RAS}}$ (PF5)	B	DRAM address strobes/General-purpose port F
143	$\overline{\text{CAS}}$ (PF6)	B	
144	IA6	O	Image processor memory address bus
145	IA5	O	
146	IA4	O	
147	IA3	O	
148	IA2	O	
149	IA1	O	
150	IA0	O	
151	ICS	O	Image processor memory chip select
152	ICLK (PD3)	B	Image processor external clock/General-purpose port D
153	SPCLK (PD2)	B	Speaker clock output/General-purpose port D
154	BACK (PD1)	B	External master device bus acknowledge signal/General-purpose port D
155	BREQ (PD0)	B	External master device bus request signal/General-purpose port D
156	TEST1	I	Test pins
157	TEST0	I	
158	$\overline{\text{BACKUP}}$	I	Power-down signal
159	EMU	I	ICE monitor in-operation signal
160	V _{DD}	P	Supply pin

1. I = input, B = bidirectional, O = output, P = power

Specifications

Absolute Maximum Ratings at V_{SS} = 0V

Parameter	Symbol	Conditions	Rating	Unit
Maximum supply voltage	V _{DD} max	T _a = 25°C	-0.3 to +7.0	V
Input/output voltage	V _I , V _O	T _a = 25°C	-0.3 to V _{DD} + 0.3	V
Allowable power dissipation	P _d max	T _a ≤ 70°C	600	mW
Operating temperature	T _{opr}		-30 to +70	°C
Storage temperature	T _{stg}		-55 to +125	°C
Soldering temperature	T _{sol}	Manual soldering (3s)	350	°C
		Reflow soldering (10s)	235	°C

Allowable Operating Ranges at T_a = -30 to +70°C, V_{SS} = 0V

Parameter	Symbol	Conditions	Min	Typ	Max	Unit
Supply voltage	V _{DD}		4.5	-	5.5	V
Input voltage	V _{IN}		0	-	V _{DD}	V

LC82141

DC Characteristics at $T_a = -30$ to $+70^\circ\text{C}$, $V_{DD} = 4.5$ to 5.5V

Parameter	Symbol	Conditions	Min	Typ	Max	Unit
Input high-level voltage	V_{IH1}	All inputs except PCK (SCLK)	2.2	-	-	V
Input low-level voltage	V_{IL1}	All inputs except PCK (SCLK)	-	-	0.8	V
Input high-level voltage	V_{IH2}	PCK (SCLK), Schmitt trigger input	2.5	-	-	V
Input low-level voltage	V_{IL2}	PCK (SCLK), Schmitt trigger input	-	-	0.6	V
Input leakage current	I_L		-25	-	+25	μA
Output high-level voltage	V_{OH}	$I_{OH} = -3\text{mA}$	2.4	-	-	V
Output low-level voltage	V_{OL}	$I_{OL} = 3\text{mA}$	-	-	0.4	V
Output leakage current	I_{OZ}	High-impedance output	-100	-	+100	μA
Oscillator frequency	f_{CLK1}	CLKIN, CLKOUT	-	-	16	MHz
	f_{CLK2}	ICLK, TCLK0, TCLK1	-	-	16	MHz
	f_{CLK3}	ROSC1, ROSC2	-	32.768	-	kHz
Current dissipation	I_{DD1}	Operating normally	-	50	90	mA
	I_{DD2}	Power-down, $V_{DD} = 2\text{V}$, BACKUP = LOW	-	3	5	μA

Function Outline

CPU Peripheral Circuits

- Generates 80-series CPU compatible CS/RD/WR signals
- Chip select signal outputs for program ROM, SRAM and I/O device connections
- ROM, SRAM and DRAM sizes settable in 64KB units
- Inserts wait cycles when accessing ROM, SRAM and I/O
- Internal/external DMA controller bus arbitration function

Image Processor

- Number of processed picture elements (pels)
 - 2048 pels/line (uses 64K memory, with black and white correction)
 - 4096 pels/line (uses 64K memory, with white correction only)
 - 4096 pels/line (uses 256K memory, with black and white correction)
- 500ns/pel max. processing rate
- 1 external, medium-speed memory
 - 100ns access time at 500ns/pel rate
- Various kinds of clocks
 - Internal clock mode, with 1, 1/2, 1/4, 1/8 frequency division capability
 - External clock mode, with optional external clock input capability
- AGC, 8-bit A/D converter built-in (with delay adjust function)
- Thermal printer head temperature monitor function
- Sensor drive circuit (CCD, various CIS types)
- Digital clamp (dot clamp, even-odd clamp)
- Distortion correction (white, black, all pels)

- γ correction (user-definable curve)
- Simple two-value processing (fixed threshold value, density-adjusted threshold value)
- Half-tone processing
 - Systematic dither method (64 gradations), dither threshold value adjustable
 - Error diffusion method (64 gradations)
- Image reduction (thinning out, black fine line hold, white fine line hold)

Codec Accelerator

- Image data dot change detection, run-length or line start absolute address output
- Run-length image data coding
- Maximum 4K run-length processing
- Image data DMA transmission capability

TPH Interface

- 4MHz, 2MHz, 1MHz and 500kHz transmission clock frequency
- Switchable rising-edge/falling-edge clock phase
- Strobe division: 1, 2, and 4
- Strobe width: 32 μs to 8.16ms
- Switchable strobe and latch pulse polarity
- Strobe and latch pulse can be generated manually and treated as a general-purpose output port
- Head supply ON/OFF control
- Head protection input pin (PROTECT) setup
 - Mode 1: HVON and STB0 to STB3 are set to inactive state after a continuous low-level input of approximately 64 ms
 - Mode 2: HVON and STB0 to STB3 are set to inactive state immediately after a low-level signal input.

Motor Interface

- Transmit/receive 2-channel stepping motor interface
- 4-phase motor (excitation method: 1 phase/2 phases/1-2 phases)
- Forward/reverse-selectable control register
- Motor output polarity selectable
- 2 phase change triggers (register-selectable) for both transmit and receive
 - Transmit motor trigger
 - Phase change by register bit ON/OFF
 - Phase change by image processor-controlled motor phase advance trigger
 - Receive motor trigger
 - Phase change by register bit ON/OFF
 - Phase change by timer 3 output

DMA Controller

- 3-channel transmission, memory ↔ I/O
 - Channel 0: Image processor → memory
 - Channel 1: Codec accelerator ↔ memory
 - Channel 2: Memory → TPH interface
- Channel 2 supporting a latchless head
- 16MB addresses/64K transfer count
- 2.6MB/s max. transfer speed
- Individual DMA request permit/prohibit
- Auto-initialization function
- Fixed precedence order: channel 0 > channel 1 > channel 2

Timer

- 6 independent 16-bit counters on-chip
- 8-bit prescaler on-chip for each counter
- 244Hz to 15.6kHz speaker clock generator
- External clock inputs selectable for timer 0 and timer 1

DRAM Controller

- 256K/1M/4Mb DRAM support, up to 120ns access time supported
- CAS-before-RAS refresh
- Employs early-write mode
- Internal refresh counter: 4ms refresh time for 256K, 8ms for 1M, 16ms for 4M
- Register setting capability for 9 dummy refresh cycle execution

Interrupt Controller

- 18-level interrupt control (internal: 14 levels, external: 4 levels)
- Individual level mask processing
- Interrupt vector address output

RTC

- Time function with alarm
- 100-year calendar
- 12-hour/24-hour time display, summer time set capability
- Leap year, short/long month auto-correction
- Selectable binary or BCD data for time, calendar and alarm
- 3 types of interrupts
 - Alarm interrupt
 - Periodic interrupt
 - Update ended interrupt

General-Purpose Ports

- 20 to 32 input/output ports
- Each port can be configured as an input or output
- Extendable up to 47 ports by switchover to dedicated pins

Sample Application Circuit

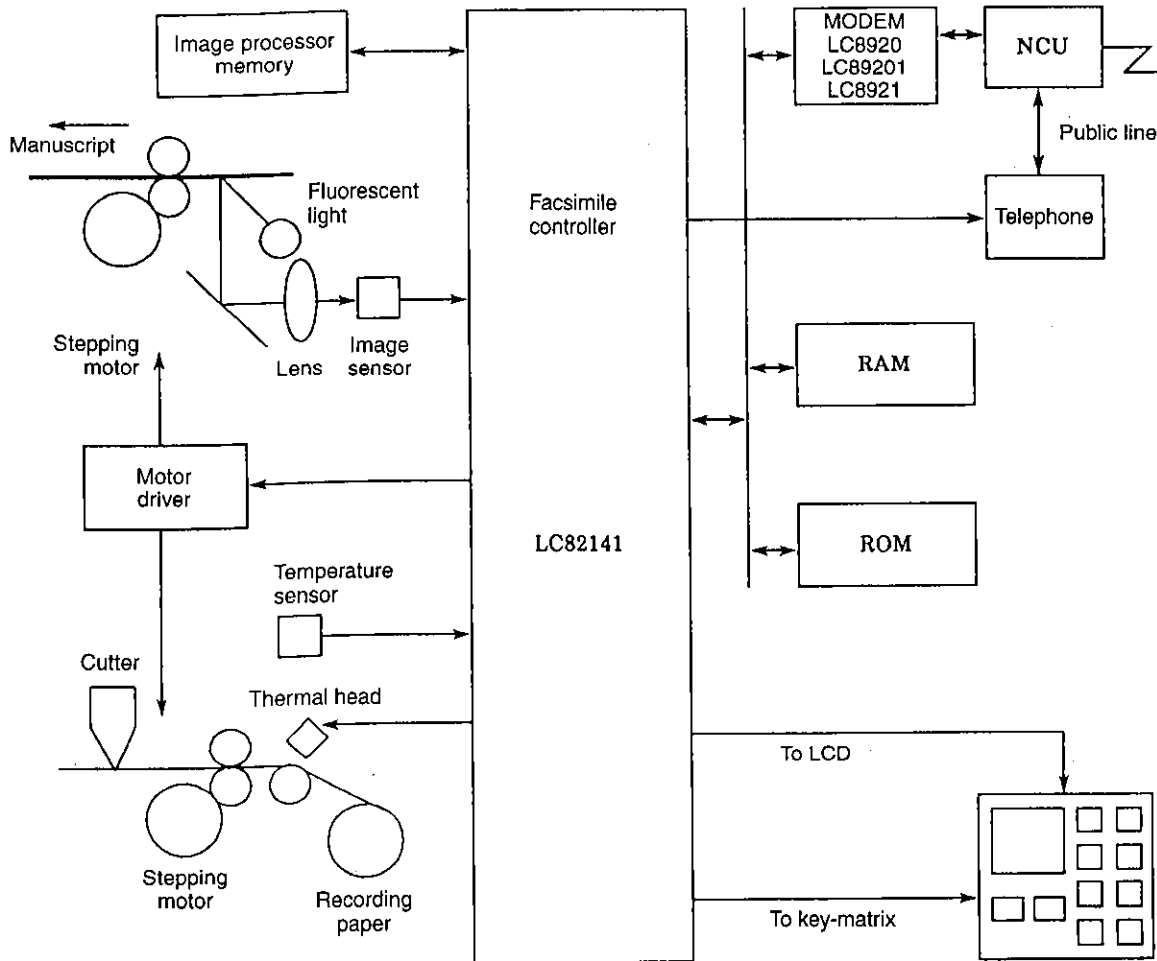

■ No products described or contained herein are intended for use in surgical implants, life-support systems, aerospace equipment, nuclear power control systems, vehicles, disaster/crime-prevention equipment and the like, the failure of which may directly or indirectly cause injury, death or property loss.

■ Anyone purchasing any products described or contained herein for an above-mentioned use shall:

- ① Accept full responsibility and indemnify and defend SANYO ELECTRIC CO., LTD., its affiliates, subsidiaries and distributors and all their officers and employees, jointly and severally, against any and all claims and litigation and all damages, cost and expenses associated with such use;
- ② Not impose any responsibility for any fault or negligence which may be cited in any such claim or litigation on SANYO ELECTRIC CO., LTD., its affiliates, subsidiaries and distributors or any of their officers and employees jointly or severally.

■ Information (including circuit diagrams and circuit parameters) herein is for example only; it is not guaranteed for volume production. SANYO believes information herein is accurate and reliable, but no guarantees are made or implied regarding its use or any infringements of intellectual property rights or other rights of third parties.