

Ordering number: EN*5600

CMOS LSI



LC86E4332

8-bit Single Chip Microcontroller

Preliminary

Overview

The LC86E4332 is a CMOS 8-bit single chip microcontroller with UVEPROM for the LC864300 series.

This microcontroller has the function and the pin description of the LC864300 series mask ROM version, and the 32K-byte EPROM. The program data is rewritable. It is suitable for developing programs.

Package Dimensions

unit : mm

3225-DIC52S

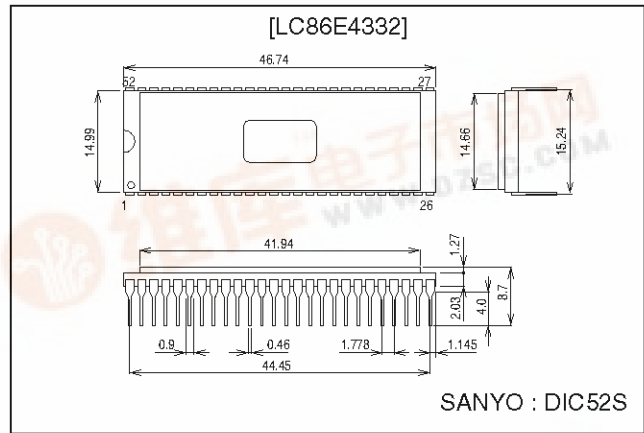

Features

- (1) Option switching by EPROM data
The option function of the LC864300 series can be specified by the EPROM data. The functions of the trial pieces can be evaluated using the mass production board.
- (2) Internal EPROM capacity : 32768 bytes (For program)
: 16384 × 12 bits (For character)
- (3) Internal RAM capacity : 384 bytes

Mask ROM version	PROM capacity	RAM capacity
LC864332	32512 bytes	384 bytes
LC864328	28672 bytes	384 bytes
LC864324	24576 bytes	384 bytes
LC864320	20480 bytes	384 bytes
LC864316	16384 bytes	384 bytes
LC864312	12288 bytes	384 bytes

- (4) Operating supply voltage : 4.5 V to 5.5 V
- (5) Instruction cycle time : 0.99 μs to 40 μs
- (6) Operating temperature : +10°C to +40°C
- (7) The pin and the package compatible with the LC864300 series mask ROM version.
- (8) Applicable mask ROM version : LC864332/LC864328/LC864324/LC864320/LC864316/LC864312
- (9) Factory shipment : DIC52S



LC86E4332

Notice for Use

When using, take notice of the followings.

(1) Differences between the LC86E4332 and the LC864300 series

Items	LC86E4332	LC864332/28/24/20/16/12
Operation after reset releasing	The option is specified by degrees until 3 ms after going to a 'H' level to the reset terminal. The program is executed from 00H of the program counter.	The program is executed from 00H of the program counter immediately after going to a 'H' level to the reset terminal.
Operating supply voltage range (V_{DD})	4.5 V to 5.5 V	4.5 V to 5.5 V
Operating temperature range (T_{opr})	+10 to +40°C	-30 to +70°C
Power dissipation	Refer to 'electrical characteristics' on the semiconductor news.	

Port configurations of LC86E4332 and LC864332/28/24/20/16/12 are identical during the reset operation.

The LC86E4332 uses the program memory area of 256 bytes from 7F00H to 7FFFH to select the options. All LC86E4332 series' options can be specified with this configuration.

(2) Option

The option data is written with the option specifying program "SU86K.EXE". The option data is linked to the program area by the linkage loader "L86K.EXE".

(3) ROM space

The LC86E4332 and LC864300 series use the program memory area of 256 bytes from 7F00H to 7FFFH to select the options. The program memory capacity of this series is, at most, 32512 bytes addressed on 0000H to 7EFFFH.

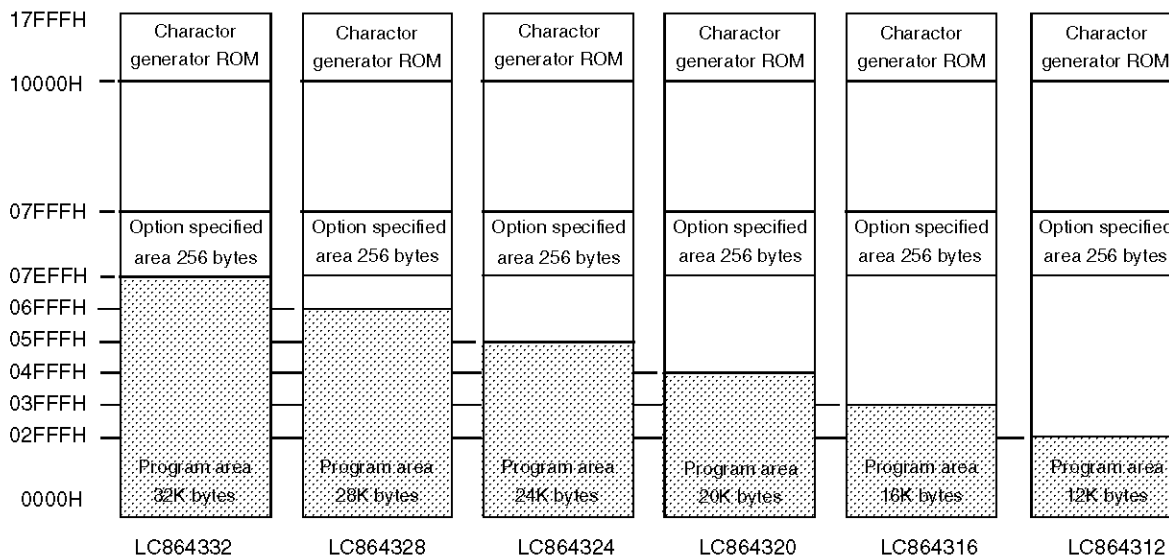

LC86E4332

How to Use

- (1) Create a programming data for LC86E4332

Programming data for EPROM of the LC86E4332 is required.

Debugged evaluation file (EVA file) must be converted to an INTEL-HEX formatted file (HEX file) with the file converter program EVA2HEX.EXE. The HEX file is used as the programming data for the LC86E4332.

- (2) How to program for the EPROM

The LC86E4332 can be programmed by the EPROM programmer with attachment W86EP4164D.

- Recommended EPROM programmer

Manufacturer	EPROM programmer
Advantest	R4945, R4944, R4943
Andou	AF-9704
AVAL	PKW-1100, PKW-3000
Minato electronics	MODEL1890A

- "27010 (Vpp = 12.5 V) Intel high speed programming" mode should be adopted.
- A jumper (DASEC) must be set to 'OFF' at programming.
- There are two ways to program the data of the hexa-decimal file described above into the EPROM of the LC86E4332.
 1. How to program the program and the character data individually.
First, the hexa-decimal data of 00h to 07FFFh is programmed into the address 00h to 07FFFh of the EPROM.
Next, write the hexa-decimal data for character addressed 10000h to 17FFFh into the address of 10000h to 17FFFh.
 2. How to program the program and the character data simultaneously.
First, copy the program data addressed from 00h to 07FFFh into the addresses 8000h to 0FFFFh with an EPROM programmer.
Next, write the data of 00h to 17FFFh into the EPROM of the LC86E4332.

An error will occur when the hexa-decimal data generated by the EVA2HEX program is programmed to the EPROM of the LC86E4332 directly.

- (3) How to use the data security function

"Data security" is the function to disable the EPROM data from being read out.

The following is the process in order to execute data security function.

1. Set the jumper of attachment 'ON'.
2. Program again. The EPROM programmer will display an error. The error means that the data security functions normally. It is not a trouble of the EPROM programmer or the LSI.

Notes

- Data security is not executed when the data of all address have 'FF' at sequence 2 above.
- Data security cannot be executed by programming the sequential operation "BLANK=>PROGRAM=>VERIFY" at procedure 2 above.
- Set the jumper to 'OFF' after executing the data security.

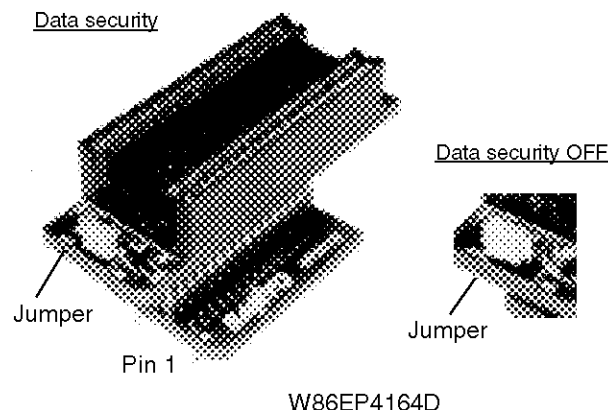

LC86E4332

Pin Assignment

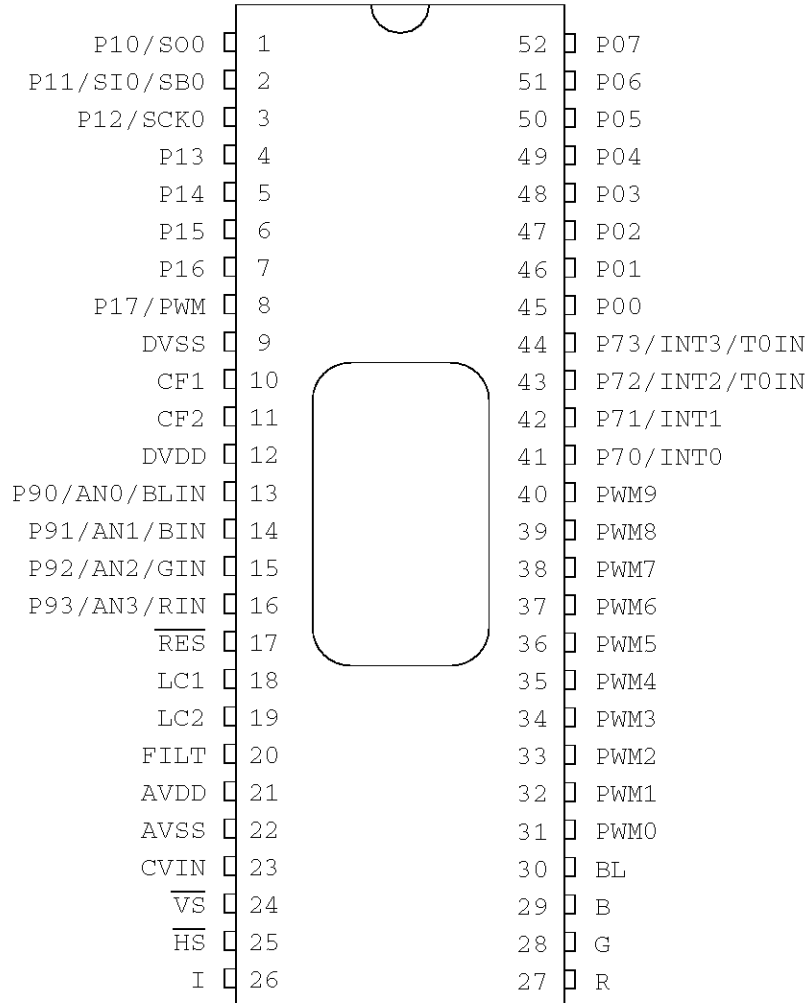

Top view

LC86E4332

System Block Diagram

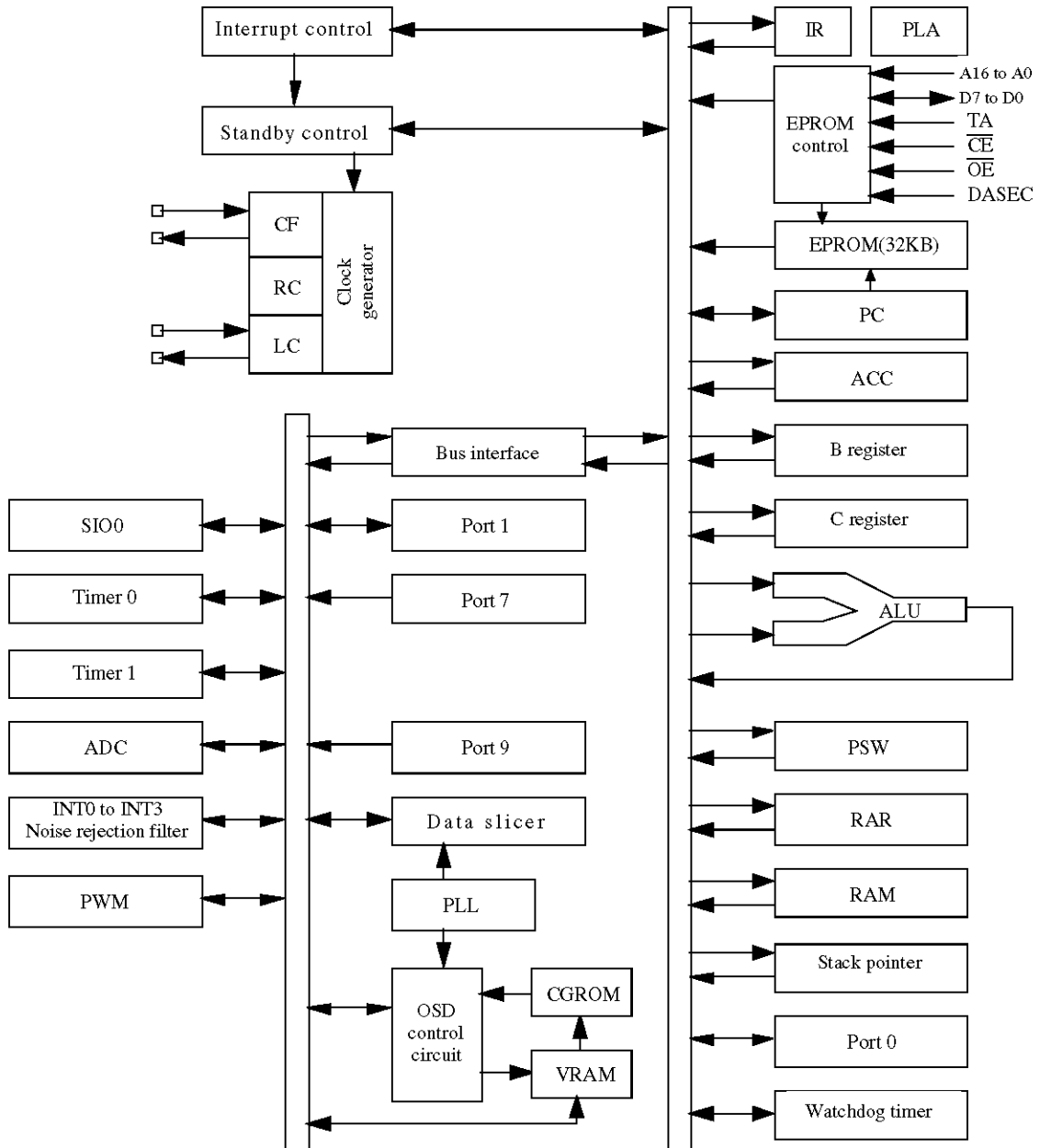

LC86E4332

Pin Description

- Port option can be specified by bit units.
- At port 0, 'Pull-up resistor provided' when specifying CMOS output.
'Pull-up resistor not provided' when specifying N-ch open drain output.
- At port 1, 'Programmable pull-up resistor provided' when specifying either CMOS or N-ch open drain output.

Pin Description Table

Pin name	Pin No.	I/O	Function description	Option	PROM mode								
DVSS	9	—	Negative power supply for digital circuit										
CF1	10	I	Input terminal for ceramic resonator										
CF2	11	O	Output terminal for ceramic resonator										
DVDD	12	—	Positive power supply for digital circuit										
$\overline{\text{RES}}$	17	I	Reset terminal										
LC1	18	I	LC oscillation circuit input terminal										
LC2	19	O	LC oscillation circuit output terminal										
FILT	20	O	Filter terminal for PLL										
AVDD	21	—	Positive power supply for analog circuit										
AVSS	22	—	Negative power supply for analog circuit										
CVIN	23	I	Video signal input terminal										
$\overline{\text{VS}}$	24	I	Vertical synchronization signal input terminal										
$\overline{\text{HS}}$	25	I	Horizontal synchronization signal input terminal										
I	26	O	Image intensity output										
R	27	O	Red (R) output terminal of RGB image output		A4 (*1)								
G	28	O	Green (G) output terminal of RGB image output		A5 (*1)								
B	29	O	Blue (B) output terminal of RGB image output		A6 (*1)								
BL	30	O	Fast blanking control signal Switch TV image signal and caption/OSD image signal		A7 (*1)								
PWM0 to PWM9	31 to 40	O	PWM0 to 9 output terminal 15 V withstand		PWM0 to 8 : A8 to A16 (*1) PWM9 : "L" fixed								
Port 0 P00 to P07	45 to 52	I/O	8-bit Input/output port Input/output can be specified in nibble units HOLD release input Interrupt input	Pull-up resistor Provided/not provided (in bit units) Output Format CMOS/Nch-OD (in bit units)									
Port 1 P10 to P17	1 to 8	I/O	8-bit Input/output port Input/output can be specified in bit units. Other function <table border="1" style="width: 100%; border-collapse: collapse;"> <tr> <td style="width: 20px;">P10</td> <td>SIO0 data output</td> </tr> <tr> <td>P11</td> <td>SIO0 data input /bus input/output</td> </tr> <tr> <td>P12</td> <td>SIO0 clock input/output</td> </tr> <tr> <td>P17</td> <td>Timer 1 (PWM) output</td> </tr> </table>	P10	SIO0 data output	P11	SIO0 data input /bus input/output	P12	SIO0 clock input/output	P17	Timer 1 (PWM) output	Output Format CMOS/Nch-OD (in bit units)	D0 to D7 (*2)
P10	SIO0 data output												
P11	SIO0 data input /bus input/output												
P12	SIO0 clock input/output												
P17	Timer 1 (PWM) output												

LC86E4332

Pin name	Pin No.	I/O	Function Description	Option	PROM mode																																	
Port 7	41 P71 to P73	I/O I	4-bit input port Other function	Pull-up resistor provided/ not provided (in bit units)	P70 : VPP (*3) P71 : DASEC (*4) P72 : \overline{OE} (*5) P73 : \overline{CE} (*6)																																	
P70			P70			INT0 input/HOLD release input/ Nch-transistor output for watchdog timer																																
P71			P71			INT1 input/HOLD release input																																
P72			P72			INT2 input/timer 0 event input																																
P73			P73			INT3 input (noise rejection filter attached input/timer 0 event input																																
			Interrupt receiver format vector address																																			
			<table border="1" style="width: 100%; border-collapse: collapse;"> <thead> <tr> <th></th> <th>Rise</th> <th>Fall</th> <th>Rise/Fall</th> <th>H level</th> <th>L level</th> <th>Vector</th> </tr> </thead> <tbody> <tr> <td>INT0</td> <td style="text-align: center;">enable</td> <td style="text-align: center;">enable</td> <td style="text-align: center;">disable</td> <td style="text-align: center;">enable</td> <td style="text-align: center;">enable</td> <td style="text-align: center;">03H</td> </tr> <tr> <td>INT1</td> <td style="text-align: center;">enable</td> <td style="text-align: center;">enable</td> <td style="text-align: center;">disable</td> <td style="text-align: center;">enable</td> <td style="text-align: center;">enable</td> <td style="text-align: center;">0BH</td> </tr> <tr> <td>INT2</td> <td style="text-align: center;">enable</td> <td style="text-align: center;">enable</td> <td style="text-align: center;">enable</td> <td style="text-align: center;">disable</td> <td style="text-align: center;">disable</td> <td style="text-align: center;">13H</td> </tr> <tr> <td>INT3</td> <td style="text-align: center;">enable</td> <td style="text-align: center;">enable</td> <td style="text-align: center;">enable</td> <td style="text-align: center;">disable</td> <td style="text-align: center;">disable</td> <td style="text-align: center;">1BH</td> </tr> </tbody> </table>		Rise	Fall	Rise/Fall	H level	L level	Vector	INT0	enable	enable	disable	enable	enable	03H	INT1	enable	enable	disable	enable	enable	0BH	INT2	enable	enable	enable	disable	disable	13H	INT3	enable	enable	enable	disable	disable	1BH
	Rise	Fall	Rise/Fall	H level	L level	Vector																																
INT0	enable	enable	disable	enable	enable	03H																																
INT1	enable	enable	disable	enable	enable	0BH																																
INT2	enable	enable	enable	disable	disable	13H																																
INT3	enable	enable	enable	disable	disable	1BH																																
Port 9	13 to 16	I	4-bit input port Other functions	External RGB input	A0 to A3 (*3)																																	
P90 to P93			AD converter input port (4 lines)																																			

*1 An → Address input

*2 Data I/O

*3 Power for programming

*4 Memory select input/output for data security

*5 Output Enable input

*6 Chip Enable input

- Port status in reset

Terminal	I/O	Pull-up resistor state at selecting pull-up option
Port 0	Input	Pull-up resistor OFF, ON after reset release
Port 1	Input	Programmable pull-up resistor OFF
Port 7	Input	Fixed pull-up resistor provided

* AVDD and AVSS are the power supply terminals for the analog operation block. DVDD and DVSS are the power supply terminals for the digital operation block. Connect as shown in the following figure to reduce the mutual noise influence.

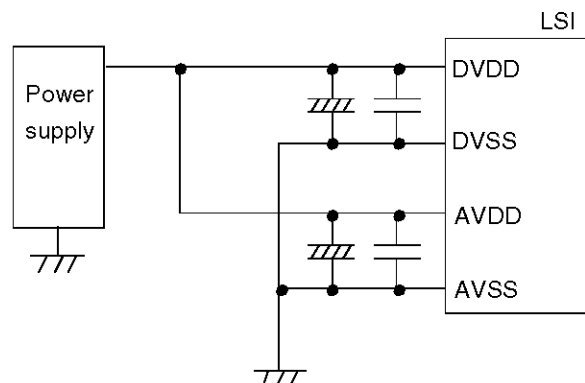

LC86E4332

Specifications

1. Absolute Maximum Ratings at Ta = 25°C, VSS = 0 V

Parameter	Symbol	Pins	Conditions	Ratings			Unit		
				VDD [V]	min	typ		max	
Supply voltage	VDD max	DVDD, AVDD	DVDD=AVDD		-0.3		+7.0	V	
Input voltage	VI(1)	<ul style="list-style-type: none"> • P71, 72, 73 • Port 9 • RES, HS, VS, CVIN 			-0.3		VDD+0.3		
Output voltage	VO(1)	R, G, B, BL, I, FILT			-0.3		VDD+0.3		
	VO(2)	PWM0 to PWM9			-0.3		+15		
Input/output voltage	VIO	Ports 0, 1, P70			-0.3		VDD+0.3		
High-level output current	Peak output current	IOPH(1)	Ports 0, 1	<ul style="list-style-type: none"> • Pull-up MOS transistor output • At each pin 		-2			mA
		IOPH(2)	Ports 0, 1	<ul style="list-style-type: none"> • CMOS output • At each pin 		-4			
		IOPH(3)	R, G, B, BL, I	<ul style="list-style-type: none"> • CMOS output • At each pin 		-5			
	Total output current	ΣIOAH(1)	Port 1	The total of all pins		-10			
		ΣIOAH(2)	Port 0	The total of all pins		-10			
		ΣIOAH(3)	R, G, B, BL, I	The total of all pins		-15			
Low-level output current	Peak output current	IOPL(1)	Ports 0, 1	At each pin				20	
		IOPL(2)	P70	At each pin				30	
		IOPL(3)	<ul style="list-style-type: none"> • R, G, B, BL, I • PWM0 to PWM9 	At each pin				5	
	Total output current	ΣIOAL(1)	Port 0	The total of all pins					40
		ΣIOAL(2)	Port 1, P70	The total of all pins					40
		ΣIOAL(3)	R, G, B, BL, I	The total of all pins					15
		ΣIOAL(4)	PWM0 to PWM9	The total of all pins					30
Maximum power dissipation	Pd max	DIC52S	Ta = +10 to +40°C				430	mW	
Operating temperature range	Topr				+10		+40	°C	
Storage temperature range	Tstg				-55		+125		

*DVSS and AVSS must be supplied the same voltage, VSS.
DVDD and AVDD must be supplied the same voltage, VDD.

VSS = DVSS = AVSS
VDD = DVDD = AVDD

LC86E4332

2. Recommended Operating Range at Ta = +10°C to +40°C, VSS = 0 V

Parameter	Symbol	Pins	Conditions	Ratings			Unit	
				V _{DD} [V]	min	typ		max
Operating supply voltage range	V _{DD}	DVDD, AVDD	0.97 μs ≤ tCYC tCYC ≤ 1.02 μs		4.5		5.5	V
Hold voltage	V _{HD}	DVDD, AVDD	RAMs and the registers hold data at HOLD mode.		2.0		5.5	
Input high-level voltage	V _{IH} (1)	Port 0 (Schmitt)	Output disable	4.5 to 5.5	0.6V _{DD}		V _{DD}	
	V _{IH} (2)	• Port 1 (Schmitt) • <u>P72</u> , <u>73</u> • <u>HS</u> , <u>VS</u>	Output disable	4.5 to 5.5	0.75V _{DD}		V _{DD}	
	V _{IH} (3)	• P70 port input / interrupt • <u>P71</u> • <u>RES</u> (Schmitt)	Output N-channel transistor OFF	4.5 to 5.5	0.75V _{DD}		V _{DD}	
	V _{IH} (4)	• P70 Watchdog timer input	Output N-channel transistor OFF	4.5 to 5.5	V _{DD} -0.5		V _{DD}	
	V _{IH} (5)	Port 9 port input		4.5 to 5.5	0.7V _{DD}		V _{DD}	
Input low-level voltage	V _{IL} (1)	Port 0 (Schmitt)	Output disable	4.5 to 5.5	V _{SS}		0.2V _{DD}	
	V _{IL} (2)	• Port 1 (Schmitt) • <u>P72</u> , <u>73</u> • <u>HS</u> , <u>VS</u> • Port 9	Output disable	4.5 to 5.5	V _{SS}		0.25V _{DD}	
	V _{IL} (3)	• P70 port input / interrupt • <u>P71</u> • <u>RES</u> (Schmitt)	N-channel transistor OFF	4.5 to 5.5	V _{SS}		0.25V _{DD}	
	V _{IL} (4)	• P70 Watchdog timer input	N-channel transistor OFF	4.5 to 5.5	V _{SS}		0.6V _{DD}	
	V _{IL} (5)	Port 9 port input		4.5 to 5.5	V _{SS}		0.3V _{DD}	
CVIN input amplitude	V _{CVIN}	CVIN		5.0	1Vp-p -3dB	1Vp-p	1Vp-p +3dB	Vp-p
Operation cycle time	tCYC(1)		OSD function	4.5 to 5.5	0.97	1	1.02	μs
	tCYC(2)		Except OSD function	4.5 to 5.5	0.97		40	

* Vp-p : Peak-to-peak voltage

LC86E4332

Parameter	Symbol	Pins	Conditions	Ratings			Unit	
				V _{DD} [V]	min	typ		max
Oscillation frequency range (Note 1)	FmCF(1)	CF1, CF2	12 MHz (ceramic resonator oscillation) Refer to Figure 1.	4.5 to 5.5	11.76	12	12.24	MHz
	FmCF(2)		12.08 MHz (ceramic resonator oscillation) Refer to Figure 1.		11.84	12.08	12.32	
	FmLC	LC1, LC2	14.11 MHz (LC oscillation) Refer to Figure 2.	4.5 to 5.5		14.11		
	FmRC		RC oscillation	4.5 to 5.5	0.4	0.8	3.0	
Oscillation stable time period (Note 2)	tmsCF(1)	CF1, CF2	12 MHz (ceramic resonator oscillation) Refer to Figure 3.	4.5 to 5.5		0.02	0.2	ms
	tmsCF(2)		12.08 MHz (ceramic resonator oscillation) Refer to Figure 3.			0.02	0.2	

(Note 1) Refer to Table 1 and Table 2 for oscillation constant.

(Note 2) The oscillation stable time period refers to the time it takes to oscillate stably after the following conditions.

1. Applying the first supply voltage.
 2. Release of the HOLD mode.
 3. Release of the stopping of the main-clock oscillation.
- Refer to Figure 3 for details.

LC86E4332

3. Electrical Characteristics at $T_a = +10^\circ\text{C}$ to $+40^\circ\text{C}$, $V_{SS} = 0\text{ V}$

Parameter	Symbol	Pins	Conditions	Ratings			Unit	
				V_{DD} [V]	min	typ		max
Input high-level current	$I_{IH}(1)$	<ul style="list-style-type: none"> Port 1 Port 0 without pull-up MOS transistor 	<ul style="list-style-type: none"> Output disable Pull-up MOS transistor OFF $V_{IN} = V_{DD}$ (including the off-leak current of the output transistor) 	4.5 to 5.5			1	μA
	$I_{IH}(2)$	<ul style="list-style-type: none"> Port 7 without pull-up MOS transistor Port 9 $\overline{\text{RES}}$ $\overline{\text{HS}}, \overline{\text{VS}}$ 	$V_{IN} = V_{DD}$	4.5 to 5.5			1	
Input low-level current	$I_{IL}(1)$	<ul style="list-style-type: none"> Port 1 Port 0 without pull-up MOS transistor 	<ul style="list-style-type: none"> Output disable Pull-up MOS transistor OFF $V_{IN} = V_{SS}$ (including the off-leak current of the output transistor) 	4.5 to 5.5	-1			
	$I_{IL}(2)$	<ul style="list-style-type: none"> Port 7 without pull-up MOS transistor Port 9 	$V_{IN} = V_{SS}$	4.5 to 5.5	-1			
	$I_{IL}(3)$	<ul style="list-style-type: none"> $\overline{\text{RES}}$ $\overline{\text{HS}}, \overline{\text{VS}}$ 	$V_{IN} = V_{SS}$	4.5 to 5.5	-1			
Output high-level voltage	$V_{OH}(1)$	CMOS output of ports 0, 1	$I_{OH} = -1.0\text{ mA}$	4.5 to 5.5	$V_{DD}-1$			V
	$V_{OH}(2)$	R, G, B, BL, I	$I_{OH} = -0.1\text{ mA}$	4.5 to 5.5	$V_{DD}-0.5$			
Output low-level voltage	$V_{OL}(1)$	Ports 0, 1	$I_{OL} = 10\text{ mA}$	4.5 to 5.5			1.5	
	$V_{OL}(2)$	Ports 0, 1	<ul style="list-style-type: none"> $I_{OL} = 1.6\text{ mA}$ The total current of the ports 0, 1 is 40 mA or less. 	4.5 to 5.5			0.4	
	$V_{OL}(3)$	R, G, B, BL, I	<ul style="list-style-type: none"> $I_{OL} = 3.0\text{ mA}$ PWM0 to PWM9 The current of any unmeasured pin is 3 mA or less. 	4.5 to 5.5			0.4	
	$V_{OL}(4)$	P70	$I_{OL} = 1\text{ mA}$	4.5 to 5.5			0.4	
Pull-up MOS transistor resistance	Rpu	<ul style="list-style-type: none"> Ports 0, 1 Port 7 	$V_{OH} = 0.9V_{DD}$	4.5 to 5.5	13	38	80	$\text{k}\Omega$
Output off-leakage current	I_{OFF}	PWM0 to PWM9	$V_{OUT} = 13.5\text{ V}$	4.5 to 5.5			5	μA
Hysteresis voltage	V_{HIS}	<ul style="list-style-type: none"> Ports 0, 1 Port 7 $\overline{\text{RES}}$ $\overline{\text{HS}}, \overline{\text{VS}}$ 	Output disable	4.5 to 5.5		$0.1V_{DD}$		V

LC86E4332

Parameter	Symbol	Pins	Conditions	Ratings			Unit	
				V _{DD} [V]	min	typ		max
Input clamp voltage	V _{CLMP}	CVIN		5.0	2.3	2.5	2.7	V
Pin capacitance	CP	All pins	<ul style="list-style-type: none"> • f = 1 MHz • Unmeasured terminals for the input are set to V_{SS} level. • Ta = 25°C 	4.5 to 5.5		10		pF

4. Serial Input/Output Characteristics at Ta = +10°C to +40°C, V_{SS} = 0 V

Parameter	Symbol	Pins	Conditions	Ratings			Unit		
				V _{DD} [V]	min	typ		max	
Serial clock	Input clock	Cycle	tCKCY(1)	<ul style="list-style-type: none"> • SCK0 • SCLK0 Refer to Figure 5.	4.5 to 5.5	2			tCYC
		Low-level pulse width	tCKL(1)			1			
		High-level pulse width	tCKH(1)			1			
	Output clock	Cycle	tCKCY(2)	<ul style="list-style-type: none"> • SCK0 • SCLK0 • Use a pull-up resistor (1 kΩ) when open drain output • Refer to Figure 5.	4.5 to 5.5	2			
		Low-level pulse width	tCKL(2)				1/2tCKCY		
		High-level pulse width	tCKH(2)				1/2tCKCY		
Serial input	Data set-up time	tICK	<ul style="list-style-type: none"> • SI0 • Data set-up to SCK0 rising • Data hold from SCK0 rising • Refer to Figure 5.	4.5 to 5.5	0.1			μs	
	Data hold time	tCKI		4.5 to 5.5	0.1				
Serial output	Output delay time (External serial clock)	tCKO(1)	<ul style="list-style-type: none"> • SO0 • Use a pull-up resistor (1 kΩ) when open drain output • Data set-up to SCK0 falling • Data hold from SCK0 falling • Refer to Figure 5.	4.5 to 5.5			7/12tCYC +0.2	μs	
	Output delay time (Internal serial clock)	tCKO(2)		4.5 to 5.5			1/3tCYC +0.2		

LC86E4332

5. Pulse Input Conditions at Ta = +10°C to +40°C, V_{SS} = 0 V

Parameter	Symbol	Pins	Conditions	Ratings			Unit	
				V _{DD} [V]	min	typ		max
High/low level pulse width	tPIH(1) tPIL(1)	• INT0, INT1 • INT2/T0IN	• Interrupt acceptable • Timer0-countable	4.5 to 5.5	1			tCYC
	tPIH(2) tPIL(2)	INT3/T0IN (The noise rejection clock is set to 1/1)	• Interrupt acceptable • Timer0-countable	4.5 to 5.5	2			
	tPIH(3) tPIL(3)	INT3/T0IN (The noise rejection clock is set to 1/16)	• Interrupt acceptable • Timer0-countable	4.5 to 5.5	32			
	tPIL(4)	$\overline{\text{RES}}$	Reset acceptable	4.5 to 5.5	200			μs
	tPIH(5) tPIL(5)	$\overline{\text{HS}}, \overline{\text{VS}}$	Display position controllable Each active edge of $\overline{\text{HS}}, \overline{\text{VS}}$ must be more than 1tCYC. Refer to Figure 7.	4.5 to 5.5	10			tCYC
Rising/falling time	tTHL tTLH	$\overline{\text{HS}}$	Refer to Figure 7.	4.5 to 5.5			500	ns
Horizontal pull-in range	FH	$\overline{\text{HS}}$	The monitor point in Figure 10 is 1/2 V _{DD} .	4.5 to 5.5	15.23	15.73	16.23	kHz

6. A/D Converter Characteristics at Ta = +10°C to +40°C, V_{SS} = 0 V

Parameter	Symbol	Pins	Conditions	Ratings			Unit	
				V _{DD} [V]	min	typ		max
Resolution	N			4.5 to 5.5		5		bit
Absolute precision	ET		(Note 3)	4.5 to 5.5		±1/4	±3/4	LSB
Conversion time	tCAD	From Vref selection to when the result is output	1 bit conversion time = 2tCYC	4.5 to 5.5		2		μs
Reference current	I _{REF}		(Regulate the ladder resistor)	4.5 to 5.5		1.0	2.0	mA
Analog input voltage range	V _{AIN}	AN0 to AN3		4.5 to 5.5	V _{SS}		V _{DD}	V
Analog port input current	I _{AINH}		V _{AIN} = V _{DD}	4.5 to 5.5			1	
	I _{AINL}	V _{AIN} = V _{SS}	4.5 to 5.5	-1				

(Note 3) Absolute precision excepts quantizing error (±1/2 LSB).

LC86E4332

7. Current Drain Characteristics at Ta = +10°C to +40°C , V_{SS} = 0 V

Parameter	Symbol	Pins	Conditions	Ratings			Unit	
				V _{DD} [V]	min	typ		max
Current drain during basic operation (Note 4)	I _{DDOP} (1)	DVDD, AVDD	<ul style="list-style-type: none"> • FmCF = 12 MHz or FmCF = 12.08 MHz when ceramic resonator oscillation • FmLC = 14.11 MHz when LC oscillation • System clock : CF oscillation • Internal RC oscillation stops 	4.5 to 5.5		25	38	mA
Current drain in HALT mode (Note 4)	I _{DDHALT} (1)	DVDD, AVDD	<ul style="list-style-type: none"> • HALT mode • FmCF = 12 MHz or FmCF = 12.08 MHz when ceramic resonator oscillation • FmLC = 0 Hz (when oscillation stops) • System clock : CF oscillation • Internal RC oscillation stops. 	4.5 to 5.5		5	10	mA
	I _{DDHALT} (2)	DVDD, AVDD	<ul style="list-style-type: none"> • HALT mode • FmCF = 0 MHz (when oscillation stops) • FmLC = 0 Hz (when oscillation stops) • System clock : Internal RC 	4.5 to 5.5		600	1200	μA
Current drain in HOLD mode (Note 4)	I _{DDHOLD}	DVDD, AVDD	<ul style="list-style-type: none"> • HOLD mode • All oscillation stops. 	4.5 to 5.5		0.05	20	μA

(Note 4) The currents to the output transistors and the pull-up MOS transistors are ignored.

LC86E4332

Oscillation types	Manufacturer	Oscillator	C1	C2
12 MHz ceramic resonator oscillation	Murata	CSA12.0MTZ	33 pF	33 pF
		CST12.0MTW	on chip	
	Kyocera	KBR-12.0M	33 pF	33 pF
12.08 MHz ceramic resonator oscillation	Murata	CSA12.0MTZ021	33 pF	33 pF
		CST12.0MTW021	on chip	
	Kyocera	KBR-12.08M	33 pF	33 pF

* Both C1 and C2 must use K rank ($\pm 10\%$) and SL characteristics.

Table 1. Ceramic Resonator Oscillation Guaranteed Constant (main-clock)

Oscillation types	L	C3	C4
14.11 MHz LC oscillation	4.7 μH	33 pF	45 pF (Trimmer)
	4.7 $\mu\text{H} \pm 10\%$ (Variable)	33 pF	33 pF

* See Figures 11 and 12.

Table 2. LC oscillation Guaranteed Constant (OSD clock)

- (Notes)
- Since the circuit pattern affects the oscillation frequency, place the oscillation-related parts as close to the oscillation pins as possible with the shortest pattern length.
 - If you use other oscillators herein, we provide no guarantee for the characteristics.
 - Adjust the voltage of monitor point in Figure 10 to $1/2 V_{DD} \pm 10\%$ by the LC oscillation constant 'L' or 'C' to lock the PLL circuit.

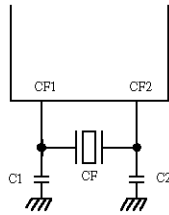

Main clock

Figure 1 Ceramic Resonator Oscillation

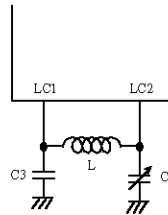

OSD clock

Figure 2 LC Resonator Oscillation

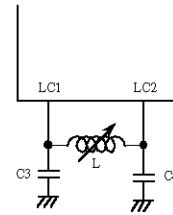

LC86E4332

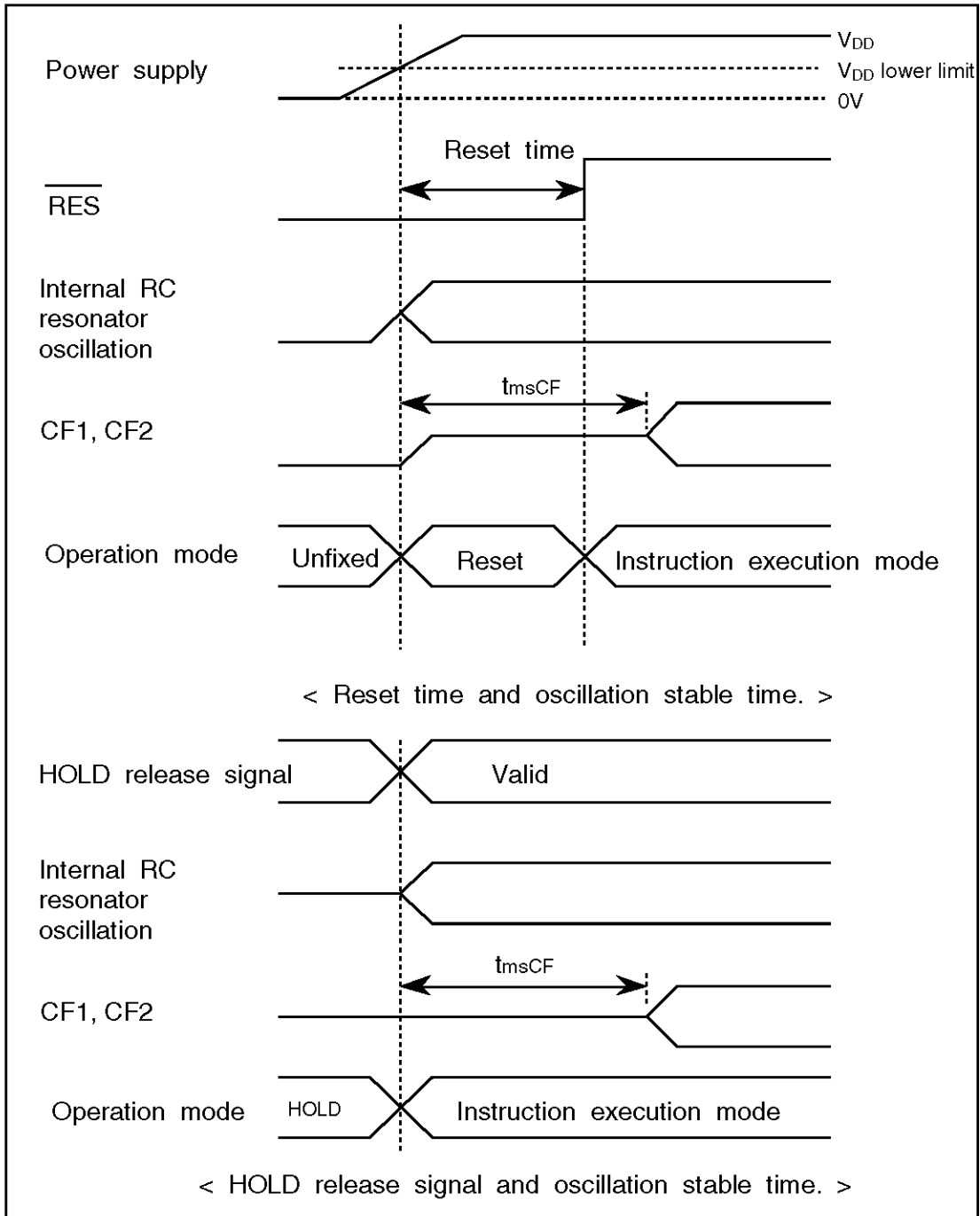
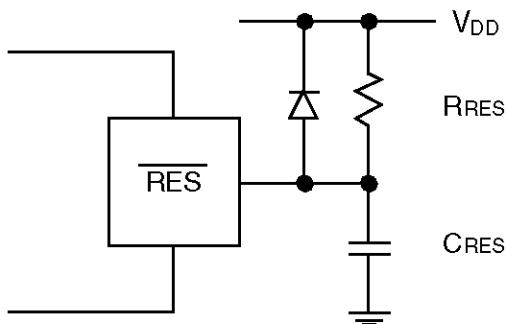

Figure 3 Oscillation Stable Time



(Note) Set the values of C_{RES} , R_{RES} so that the reset time is 200 μ s or longer.

Figure 4 Reset Circuit

LC86E4332

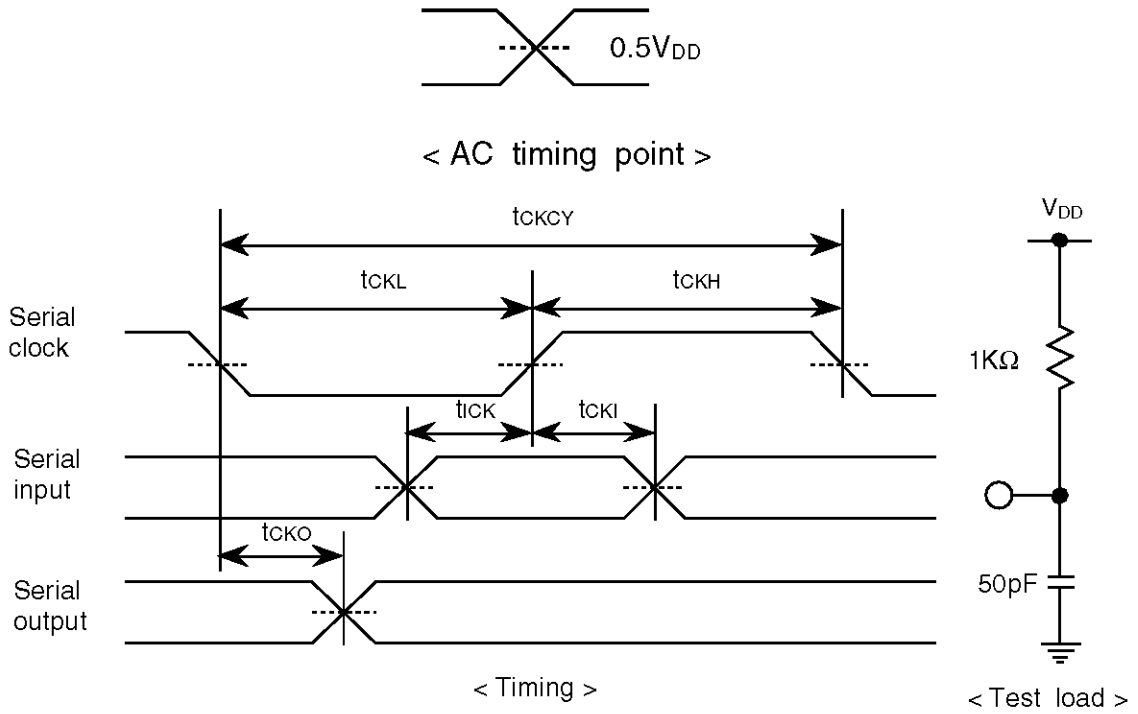

Figure 5 Serial Input/output Test Condition

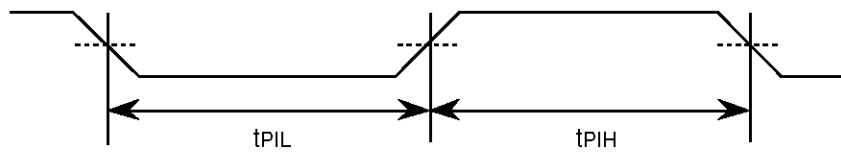

Figure 6 Pulse Input Timing Condition - 1

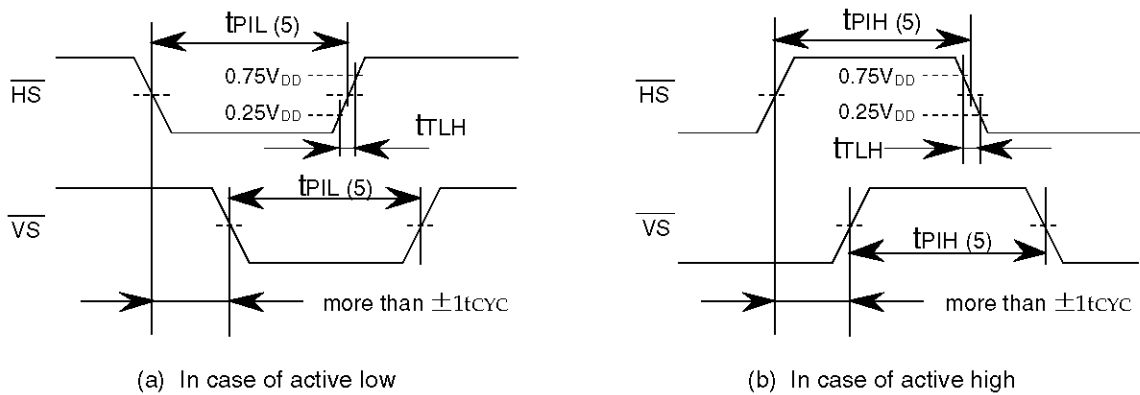

Figure 7 Pulse Input Timing Condition - 2

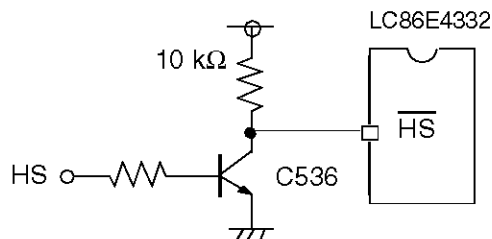

Figure 8 Recommended Interface Circuit

LC86E4332

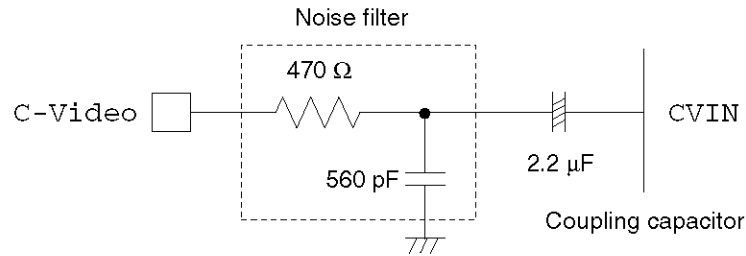

Figure 9 CVIN Recommended Circuit

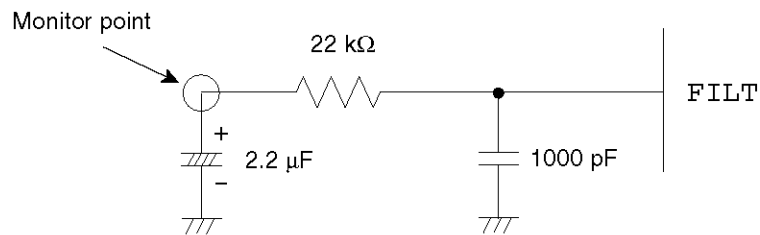

Figure 10 FILT Recommended Circuit

(Note) • Place the parts connected FILT terminal as close to the FILT as possible with the shortest pattern length on the board.

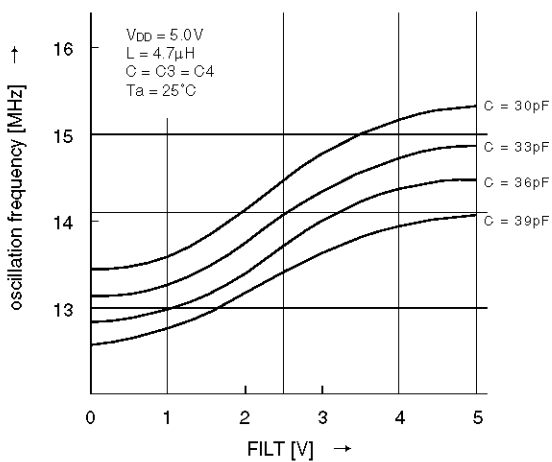

Figure 11 FILT-LC Oscillation Frequency(1)

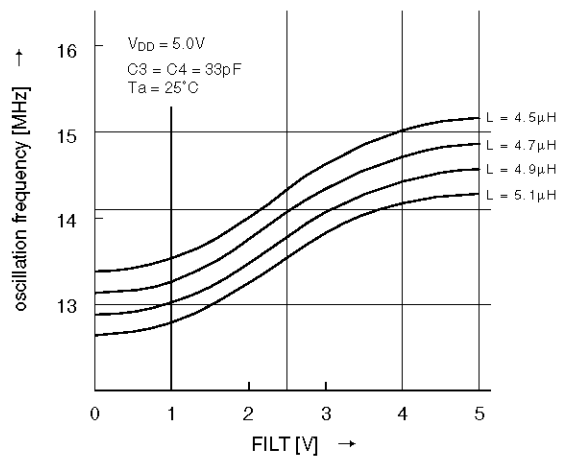

Figure 12 FILT-LC Oscillation Frequency(2)

- No products described or contained herein are intended for use in surgical implants, life-support systems, aerospace equipment, nuclear power control systems, vehicles, disaster/crime-prevention equipment and the like, the failure of which may directly or indirectly cause injury, death or property loss.
- Anyone purchasing any products described or contained herein for an above-mentioned use shall:
 - ① Accept full responsibility and indemnify and defend SANYO ELECTRIC CO., LTD., its affiliates, subsidiaries and distributors and all their officers and employees, jointly and severally, against any and all claims and litigation and all damages, cost and expenses associated with such use
 - ② Not impose any responsibility for any fault or negligence which may be cited in any such claim or litigation on SANYO ELECTRIC CO., LTD., its affiliates, subsidiaries and distributors or any of their officers and employees jointly or severally.
- Information (including circuit diagrams and circuit parameters) herein is for example only; it is not guaranteed for volume production. SANYO believes information herein is accurate and reliable, but no guarantees are made or implied regarding its use or any infringements of intellectual property rights or other rights of third parties.

This catalog provides information as of March, 1998. Specifications and information herein are subject to change without notice.