

Ordering number : EN\*5219

CMOS LSI



# LC9998G

## 1/5" Optical Size PAL Color Solid-State Image Sensor

### Preliminary

#### Overview

The LC9998G is a 1/5" optical size frame transfer type CCD (charge-coupled device) solid-state image sensor developed for use in color video cameras.

#### Features

- Effective number of pixels (total pixels): 499H × 582V (532H × 600V)
- Number of optical black pixels:  
Horizontal direction: Front: 7 pixels  
Back: 26 pixels  
Vertical direction: Front: 14 pixels  
Back: 4 pixels
- Dummy bits: Horizontal direction: 4 pixels
- Horizontal resolution: 220 TV lines
- Supports miniature, compact camera designs.
- Package: 20-pin half-pitch transparent DIP
- Horizontal shift register: 5 V drive
- Supports variable-speed electronic shutter operation

#### Device Structure

- 1/5" type frame transfer CCD image sensor
- Unit cell size: 5.8 μm (H) × 3.75 μm (V)
- Chip size: 4.18 mm (H) × 5.10 mm (V)
- Parallel gate CCD sensor
- Built-in high-sensitivity output amplifier
- Cy-G-Ye stripe complementary color filter

#### Specifications

Absolute Maximum Ratings at Ta = 25°C, VSS = 0 V

Parameter	Symbol	Conditions	Ratings	Unit
Maximum supply voltage	V <sub>DD</sub>	V <sub>PW</sub> = 0 V	-0.3 to +18	V
	V <sub>GG</sub>	V <sub>PW</sub> = 0 V	-0.3 to +5	V
	NSUB-PW		-0.3 to +50	V
	NSUB - ø1 to ø4, øS1 to øS4:		-0.3 to +55	V
Horizontal clock pin	øR	V <sub>PW</sub> = 0 V	-0.3 to +18	V
Other clock pins		V <sub>PW</sub> = 0 V	-15 to +18	V
Other pins		V <sub>PW</sub> = 0 V	-0.3 to +10	V
Operating temperature	T <sub>opr</sub>		-10 to +60	°C
Storage temperature	T <sub>stg</sub>		-30 to +80	°C

#### Package Dimensions

unit: mm

3217

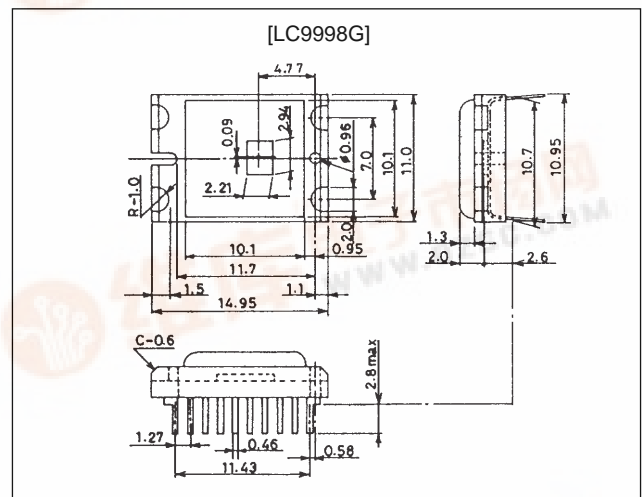

# LC9998G

## Block Diagram

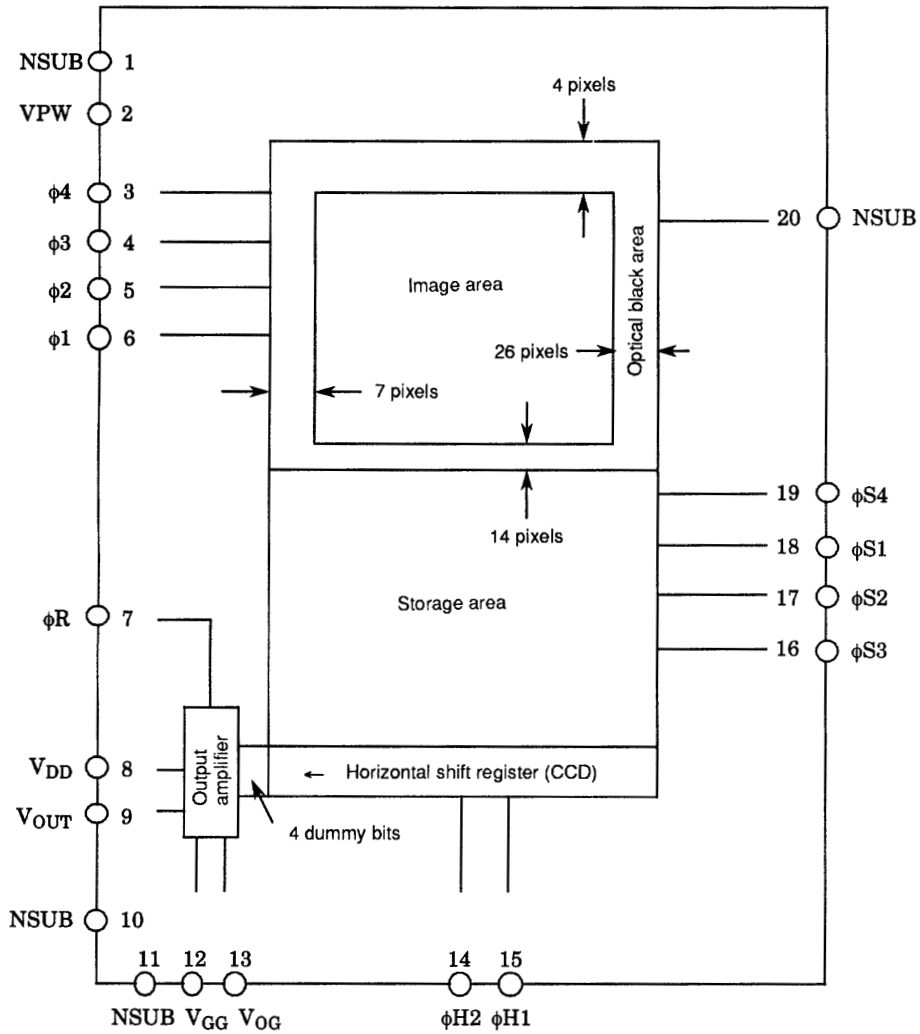

## Pin Assignment

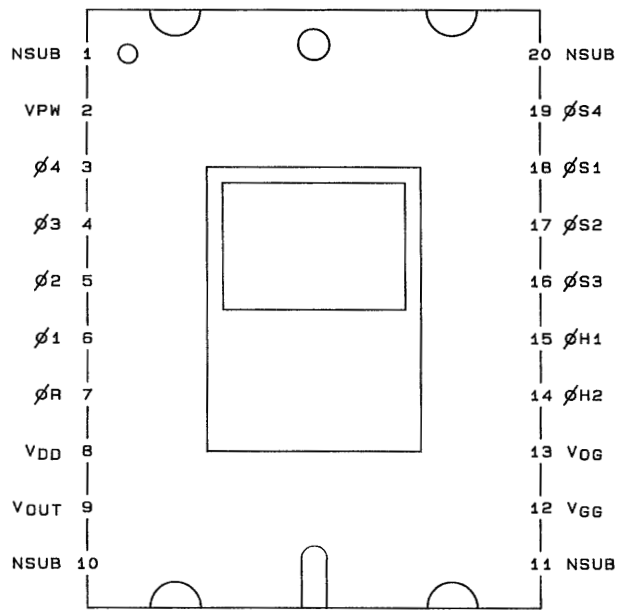



# LC9998G

## Specifications

### Clock Voltage Conditions at Frame frequency = 3.58 MHz

Parameter	Symbol	Conditions	min	typ	max	Unit	
Imaging block pulses ø1, ø2, ø3, ø4	Pulse amplitude	$V_{PIF}$	*1	14.0	14.5	15.0	V
	Low level	$V_{LIF}$		-10.0	-9.5	-9.0	V
Storage block pulses øS1, øS2	Pulse amplitude	$V_{PSL}$		14.0	14.5	15.0	V
	Low level	$V_{LSL}$		-7.0	-6.5	-6.0	V
Storage block pulses øS3, øS4	Pulse amplitude	$V_{PSL}$		14.0	14.5	15.0	V
	Low level	$V_{LSL}$		-8.0	-7.5	-7.0	V
Horizontal transfer pulses øH1, øH2	Pulse amplitude	$V_{PH}$		4.5	5.0	5.5	V
	Low level	$V_{LH}$		0	0	0.5	V
Reset gate øR	Pulse amplitude	$V_{PR}$		4.5	5.0	5.5	V
	Low level	$V_{LR}$		4.2	4.5	4.8	V
Substrate pulse øNSUB	High level	$V_{HSUB}^{*2}$	See Figure 1.	30.0		40.0	V
	Low level	$V_{LSUB}$		17.5	18.0	18.5	V

Note: 1. Insert 47 pF capacitors as shown in Figure 2.

2. Adjust  $V_{HSUB}$  within the range where image degradation does not occur so that the saturated output level is maximized.

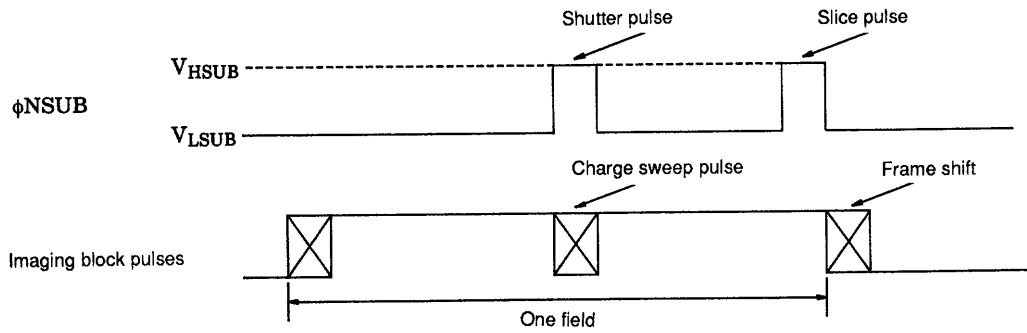

A04467

Figure 1

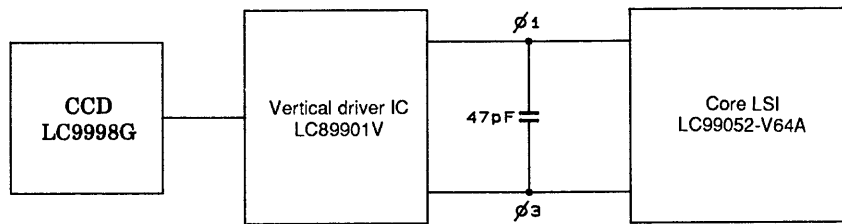

A04468

Figure 2

## LC9998G

### Bias Conditions

Parameter	Symbol	Conditions	min	typ	max	Unit
P-well	$V_{PW}$			0		V
Output circuit voltage	$V_{DD}$	*1	14.5	15.0	15.5	V
	$V_{GG}$	*2	1.2	1.5	1.8	V
OG bias	$V_{OG}$	*2	4.5	5.0	5.5	V

Note: 1. Design applications so that this level never exceeds the substrate pulse low level  $V_{LSUB}$ .  
 2. These are high-impedance inputs.

### DC Characteristics

Parameter	Symbol	Conditions	min	typ	max	Unit
DC operating current	$I_{DD}$		4.5	7.0	11.0	mA

### DC operating current

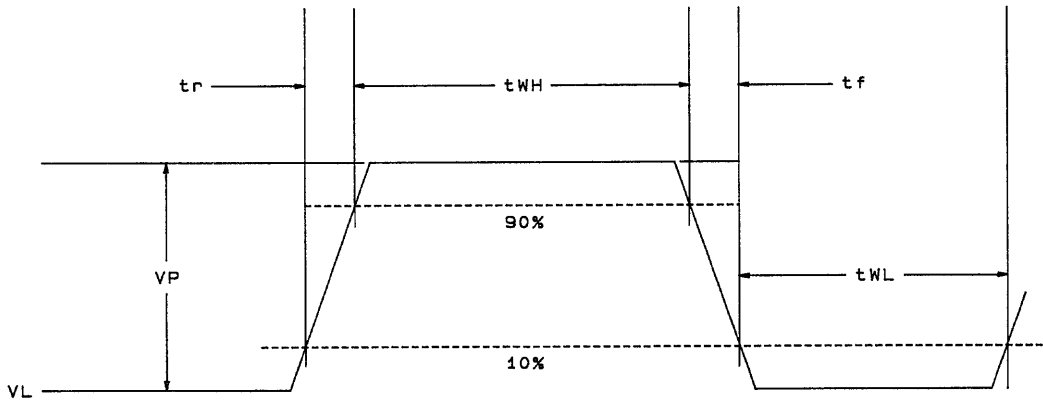

Note: VP: pulse amplitude  
 VL: low level

A04489

**Figure 3 Pulse Waveform**

Symbol	$t_{WH}$	$t_{WL}$	$t_r$	$t_f$	Conditions	Unit
	typ	typ	typ	typ		
$\phi 1$	167	102	6.5	6.5	During frame drive When the frame shift frequency is 3.55 MHz	ns
$\phi 2$	143	117	11	11		
$\phi 3$	167	102	6.5	6.5		
$\phi 4$	143	117	11	11		
$\phi S1$	143	117	11	11	During frame drive When the frame shift frequency is 3.55 MHz	ns
$\phi S2$	143	117	11	11		
$\phi S3$	143	117	11	11		
$\phi S4$	143	117	11	11		
$\phi S1$	1.4	62.5	30	30	The values enclosed in dark lines are in $\mu s$ units and apply during 1H line transfers.	ns
$\phi S2$	1.4	62.5	30	30		
$\phi S3$	62.5	1.4	30	30		
$\phi S4$	62.5	1.4	30	30		
$\phi R$	10	88	4	4	Reset pulse	ns
$\phi H1$	50	50	3	3	During horizontal transfers	
$\phi H2$	50	50	3	3		
$\phi NSUB$	9.9	19.99*	0.07	1	The slice pulse values marked * are in ms units.	$\mu s$
$\phi NSUB$	4.2	19.99*	0.07	1	The shutter pulse values marked * are in ms units.	$\mu s$

## LC9998G

### Imaging Characteristics at Ta = 25°C

Parameter	Symbol	Test method	Conditions	min	typ	max	Unit
Sensitivity	S	1		175	200	265	mV
Video signal imbalance	VF	2				15	%
Saturated signal	Vsat	3		500			mV
Smear	SM	4	*1		0.04		%
Dark signal	Vdrk	5	Ta = 55°C			7	mV
Color unevenness	Vcs	6				40	mV
Gamma characteristics	$\gamma$				1		—

Note: 1. When the frame shift frequency is 3.55 MHz and the storage time is 1/50 second.

### Test Procedures

The Sanyo evaluation board must be used for the following tests.

#### 1. Sensitivity

Use a CCV31F pattern box (manufactured by Dai Nippon Printing Co., Ltd.) set up at a brightness of 1500 NT and color temperature of 5100°K with no pattern. Image the pattern box with an HF16A lens (manufactured by Fujinon) with a 1 mm thick C-500 IR cut filter in front of that lens.

Set the lens f-stop to f8 and set the lens to be 50 cm from the pattern box. Measure the CCD output signal from the center of the image with this setup.

#### 2. Uniformity of Output Signal

Measure under the following conditions.

- Standard drive conditions (See the specifications document.)
- Use a 3200°K color temperature halogen lamp as the light source.
- Use a 1 mm thick C-500 IR cut filter.

Set the CCD surface illumination to 7 lux, and divide the image into 45 areas as shown in Figure 4.

Measure the average value for each block, and determine the maximum, minimum, and mean of those values.

Determine the ratio of the range of the block average values to the mean of the block average values.

$$VF = \frac{\text{maximum block average value} - \text{minimum block average value}}{\text{mean block average value}}$$

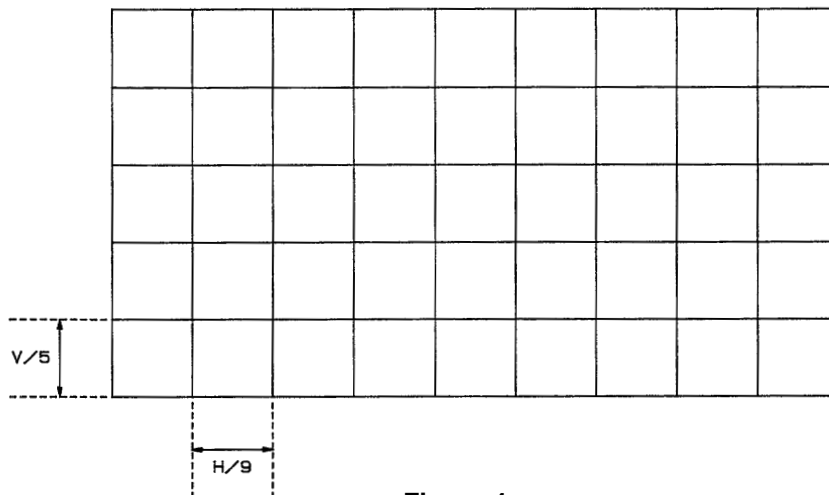

**Figure 4**

A04470

#### 3. Saturated Signal

Saturate the output signal by removing the lens in the test setup for item 1. Measure the CCD output signal from the center of the image in this state.

4. Smear

- Place a 1/10 V chart in front of the halogen light source as shown in the figure and image that chart.
- Adjust the amount of light entering the CCD with ND filters so that the CCD output signal at point A becomes 250 mV.
- Remove the ND filter(s) and measure the output value of the CCD output signal from the first line (point B).

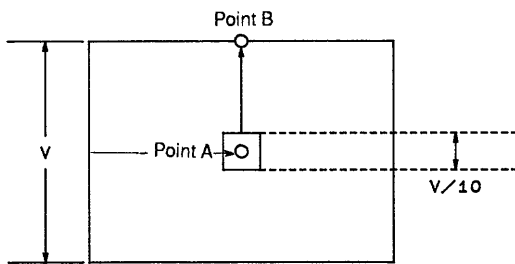

$$SM = \frac{VB \cdot TND}{250} \times 100 [\%]$$

VB: The amount of smear at point B [mV]

TND: The ND filter transmissivity

A04471

Figure 5

5. Dark Signal

Completely block all light from falling on the CCD element surface and measure the CCD output signal at the center of the image.

Here, do not measure the difference between this signal and the optical black section level, but rather measure the difference between this signal and the no signal level that has no pixel information. (See Figure 6.)

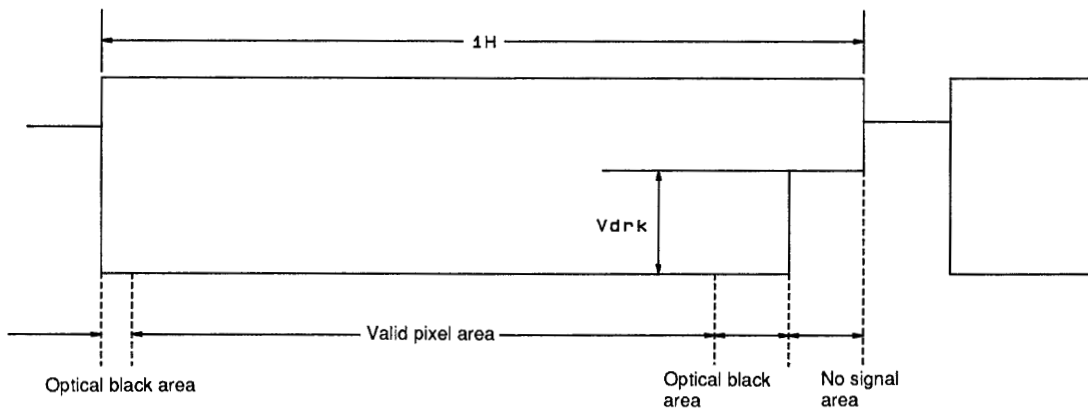

A04472

Figure 6 Structure of a Single Horizontal Period

6. Color Uniformity

Use a CCV31F pattern box (manufactured by Dai Nippon Printing Co., Ltd.) set up at a brightness of 1500 NT and color temperature of 5100°K with no pattern. Use the Sanyo LC9997-LE01 lens and a C-500 IR cut filter. Adjust the exposure with ND filters so that the CCD output signal level is 500 mV. Measure the chrominance signal level and chrominance signal phase at 16 points in the image as shown in Figure 7. Calculate the color unevenness,  $V_{CS}$  (mV), from these chrominance signal level and phase values.

$$BL = \frac{\sum_{i=1}^8 VL(i) \cos \theta L(i)}{8}$$

VL, VR : Chroma level (mV)

$\theta L, \theta R$  : Chroma level (°)

$$RL = \frac{\sum_{i=1}^8 VL(i) \sin \theta L(i)}{8}$$

$$BR = \frac{\sum_{i=1}^8 VR(i) \cos \theta R(i)}{8}$$

$$RR = \frac{\sum_{i=1}^8 VR(i) \sin \theta R(i)}{8}$$

$$V_{CS} = \sqrt{(BL - BR)^2 + (RL - RR)^2}$$

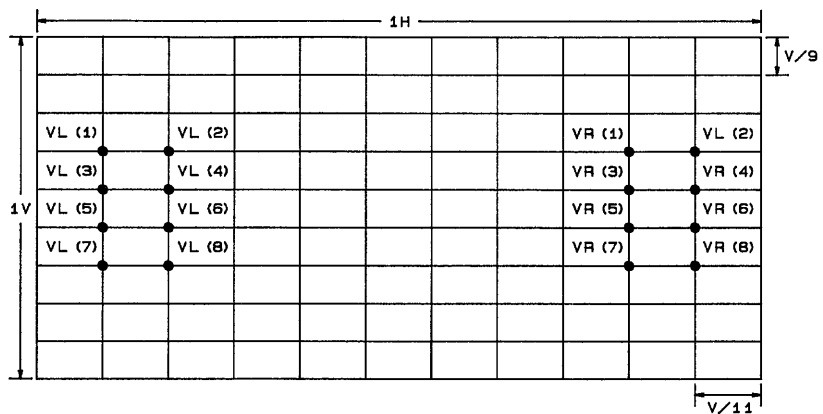

A04473

Figure 7

## LC9998G

### CCD Color Camera Block Diagram

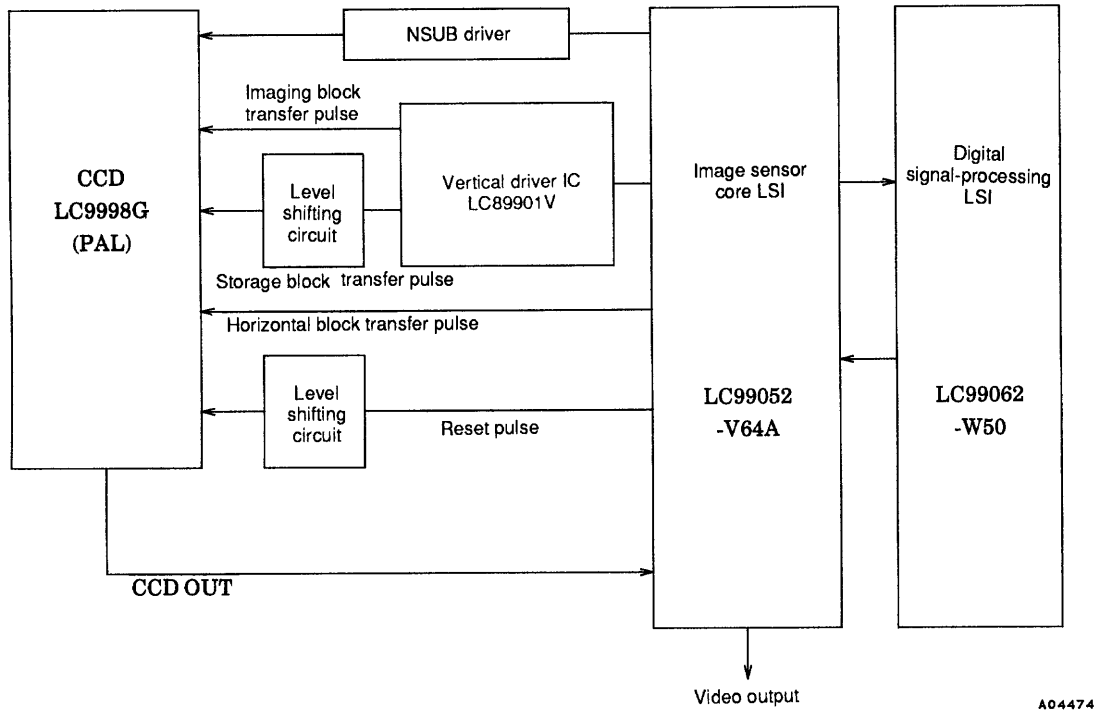

A04474

**Figure 8**

### Block Descriptions

Block	Product no.	Specifications and functions
Vertical driver	LC89901V	<ul style="list-style-type: none"> <li>• Vertical CMOS driver</li> <li>• Maximum frame transfer frequency: 3.55 MHz</li> </ul>
Image sensor core LSI	LC99052-V64A	<ul style="list-style-type: none"> <li>• CMOS standard cell</li> <li>• Built-in SSG (NTSC/PAL)</li> <li>• Electronic iris circuit that supports even long exposure times</li> <li>• Supports external image sensor drive control</li> <li>• CDS and AGC early-stage signal-processing circuits</li> <li>• Video bandwidth 8-bit A/D and D/A converters</li> <li>• Supports mirror output</li> <li>• Can also operate stand-alone</li> </ul>
Digital signal-processing LSI	LC99062-W50	<ul style="list-style-type: none"> <li>• Three channel 8-bit video signal inputs</li> <li>• Three channel 8-bit video signal outputs</li> <li>• Also functions as an RGB input encoder (NTSC/PAL)</li> <li>• Operates on HD, VD, and CLK inputs</li> <li>• Simplified chrominance keying</li> <li>• Superimpose</li> <li>• Supports parameter setting in stand-alone mode</li> </ul>

## Notes on Mounting and Handling

### 1. Preventing Electrostatic Discharge (ESD)

Since CCD sensors are easily destroyed by ESD, the antistatic measures described below should be employed when handling this device.

- All tools and personnel must be grounded when handling CCDs. Note that a 1 M $\Omega$  resistor should be inserted in series between personnel and ground for safety. (We recommend using wrist straps for personnel grounding.)
- Personnel should handle CCD devices with either bare hands or antistatic gloves. Use antistatic materials for work garments. Personnel should wear conductive shoes.
- Lay conductive mats on the floor and benches in the workplace so that static charges do not accumulate.
- We recommend using ionized air blowers (or other static removal techniques) when handling CCD sensors.
- Use antistatic boxes when transporting boards that have CCD sensors mounted on them.
- Do not leave packing materials or fittings made from plastic materials (such as Styrofoam) that easily collect static charges on or near workplace tables.
- Ground all tools, test equipment, conveyors, soldering irons, and other objects used in the workplace. Inspect grounding regularly to assure that it is complete.
- Do not handle this IC in the vicinity of TV monitors or other equipment that generates high static voltages. If unavoidable, install antistatic filters in front of monitor screens and take all other possible antistatic measures.
- Static charges accumulate easily in workplaces with a low relative humidity. Manufacturing operations should be carried out in an environment with a relative humidity of at least 50%.

### 2. Soldering

- The CCD package temperature must not exceed 80°C.
- Since CCD sensors are sensitive to thermal stress as well as ESD, the soldering iron temperature should be under 300°C. Aim for a soldering time of 2 seconds per pin.
- Use soldering irons that include an adjustable temperature control function that holds the soldering iron tip at a constant temperature.
- Be especially careful to assure that the device package temperature does not exceed 80°C when repairing or redoing solder joints or when removing CCD sensors from printed circuit boards.

### 3. Soiling and Contamination Prevention

- CCD sensors should be handled in a clean workplace. (A class 1000 level is appropriate.)
- Do not touch the package surface and do not allow any object to contact the package surface. Use compressed air to remove any foreign objects (such as dust) that land on the package surface. (We recommend using an ionized air blower if possible.)
- Use a cotton swab dipped in ethyl alcohol to remove oily contamination, being especially careful not to scratch the package surface.
- Use special-purpose cases to prevent soiling and contamination. Warm or cool CCD sensors in advance to prevent condensation when transporting between rooms with radically differing temperatures.
- For CCD sensors that are shipped with protective tape applied, only remove that tape immediately prior to use in an environment in which ESD prevention measures have been fully implemented. Do not reuse protective tape that has been removed from a CCD sensor.

## LC9998G

---

### 4. Storage

- Do not allow sunlight or other bright light to fall on CCD sensors for extended periods.
- Since harsh conditions such as high temperatures or high humidities can adversely influence device characteristics, do not use or store these devices in environments with such conditions. Samples should be stored in places where the temperature and humidity fall in normal ranges, i.e., 5 to 35°C and 45 to 75% RH.
- Since CCD sensors are precision optical components, they should not be subjected to mechanical shocks.
- Avoid locations with corrosive atmospheres or high dust levels.
- Avoid locations subject to rapid temperature changes.
- Do not place heavy objects on top of boxes containing CCD sensors during storage.
- Use materials that cannot accumulate static charges for containers used to hold samples.
- Do not subject magazines holding CCD sensors to mechanical shocks, since this could adversely influence reliability during mounting due to pin bending and other problems.

### 5. Notes on Mounting

- Flare can occur if a lens with an optical size larger than 1/5" is used. Consult your Sanyo sales representative in advance when selecting lenses.
- This product is mounted in a fully transparent plastic package, and is easily influenced by light that passes through the mounting board from the back to the front. Design end-products to adequately block out extraneous light.

### 6. Shipping

- Do not drop or throw packages containing CCD sensors.
- Do not allow packages containing CCD sensors to become wet due to rain or snow.
- Protect packages containing CCD sensors from mechanical shock and vibration as much as possible during shipping.

- No products described or contained herein are intended for use in surgical implants, life-support systems, aerospace equipment, nuclear power control systems, vehicles, disaster/crime-prevention equipment and the like, the failure of which may directly or indirectly cause injury, death or property loss.
- Anyone purchasing any products described or contained herein for an above-mentioned use shall:
  - ① Accept full responsibility and indemnify and defend SANYO ELECTRIC CO., LTD., its affiliates, subsidiaries and distributors and all their officers and employees, jointly and severally, against any and all claims and litigation and all damages, cost and expenses associated with such use:
  - ② Not impose any responsibility for any fault or negligence which may be cited in any such claim or litigation on SANYO ELECTRIC CO., LTD., its affiliates, subsidiaries and distributors or any of their officers and employees jointly or severally.
- Information (including circuit diagrams and circuit parameters) herein is for example only; it is not guaranteed for volume production. SANYO believes information herein is accurate and reliable, but no guarantees are made or implied regarding its use or any infringements of intellectual property rights or other rights of third parties.

This catalog provides information as of February, 1996. Specifications and information herein are subject to change without notice.