

Ceramic Low Pass Filter

查询LFCN-6000供应商

捷多邦, 专业PCB打样工厂, 24小时加急出货

NEW!

LFCN-6000

DC to 6000 MHz

Maximum Ratings

Operating Temperature	-55°C to 100°C
Storage Temperature	-55°C to 100°C
RF Power Input*	9W max. at 25°C
DC Current Input to Output	0.5A max. at 25°C

*Passband rating, derate linearly to 3W at 100°C ambient.

Pin Connections

RF IN	1**
RF OUT	3**
GROUND	2,4

**RF IN & RF OUT can be interchanged

Outline Drawing

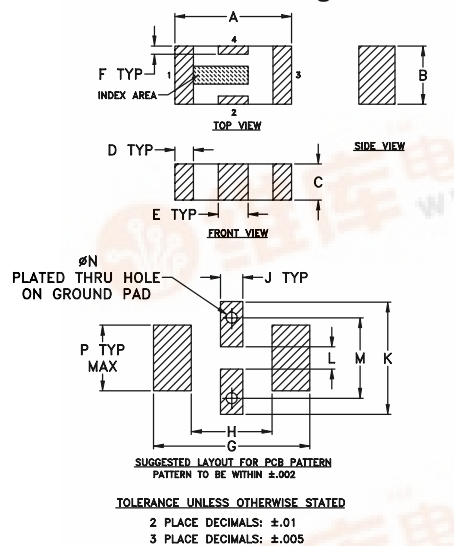

Outline Dimensions (inch/mm)

A	B	C	D	E	F	G	H
.126	.063	.039	.020	.032	.009	.169	.087
3.20	1.60	0.99	0.51	0.81	0.23	4.29	2.21
J	K	L	M	N	P	wt.	
.024	.122	.024	.087	.012	.071	grams	
0.61	3.10	0.61	2.21	0.30	1.80	.020	

Demo Board MCL P/N: TB-270 Suggested PCB Layout (PL-137)

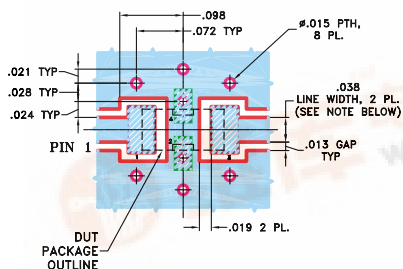

Features

- excellent power handling, 9W
- small size
- 7 sections
- temperature stable
- patent pending

Applications

- harmonic rejection
- transmitters/receivers
- lab use



BLUE CELL™

CASE STYLE: FV1206

Model	Price	Qty.
LFCN-6000	\$1.99	(10-49)
LFCN-6000D	\$2.19	(10-49)

Low Pass Filter Electrical Specifications¹ (T_{AMB}=25°C)

MODEL NO.	PASSBAND (MHz) (loss < 1 dB) Max.	f _{co} , MHz Nom. (loss 3 dB) Typ.	STOP BAND (MHz) (loss, dB)			VSWR (:1)		NO. OF SECTIONS
			f 20 Min.	30 Typ.	fr 20 Typ.	Stopband Typ.	Passband Typ.	
LFCN-6000	DC-6000	6800	8300	8500-12000	18000	20	1.3	7

1. For Applications requiring DC voltage to be applied to the Input or output, use LFCN-6000D (DC Resistance to ground is 100 Mohms min.)

typical frequency response

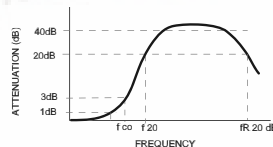

schematic

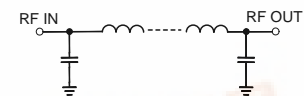

Typical Performance Data at 25°C

Frequency (MHz)	Insertion Loss (dB)	VSWR (:1)
50.00	0.10	1.01
100.00	0.02	1.01
1000.00	0.10	1.03
3000.00	0.19	1.07
5000.00	0.57	1.37
6000.00	0.75	1.24
6800.00	2.80	3.31
8000.00	21.90	15.96
8720.00	44.10	17.22
10000.00	58.33	19.76
12000.00	30.77	15.26
13700.00	27.86	1.37
15000.00	27.44	8.72
18000.00	21.31	10.02
20000.00	26.23	7.44

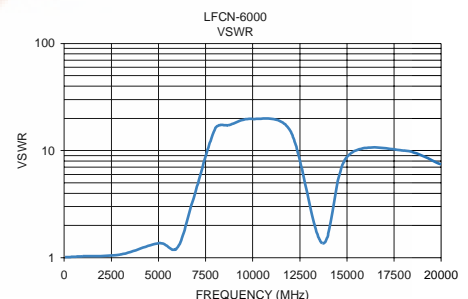
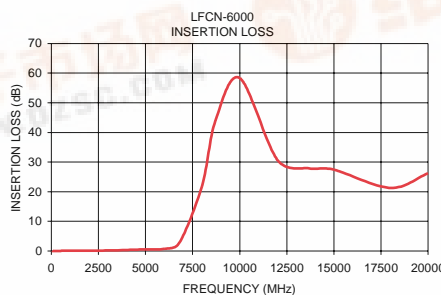

designers kit available

Kit No.	No. of Units in Kit	Description	Price \$ per Kit
K2-LFCN	60	5 of each: LFCN-800,-900,-1000,-1200,-1325,-1700,-2000,-2250,-2400,-5000,-6000,-6700	119.95

INTERNET <http://www.minicircuits.com>

P.O. Box 350166, Brooklyn, New York 11235-0003 (718) 934-4500 Fax (718) 332-4661

REV. A
M95167
LFCN 6000