



LH0075 Positive Precision Programmable Regulator

General Description

The LH0075 is a precision programmable regulator for positive voltages. Regulated output voltages from 0 to 27V may be obtained using one external resistor. Also available without any external components are several fixed regulated voltages with accuracies to 0.1% (5V, 6V, 10V, 12V and 15V). The output current limit is adjustable from 0 to 200 mA using two external resistors. These features provide an inventory of precision regulated values in one package.

Features

- Output adjustable to 0V
- Line regulation typically 0.008%/V
- Load regulation typically 0.075%
- Remote voltage sensing
- Ripple rejection of 80 dB
- Adjustable precision current limit
- Output currents to 200 mA
- Popular voltages available without external resistors

Schematic Diagram

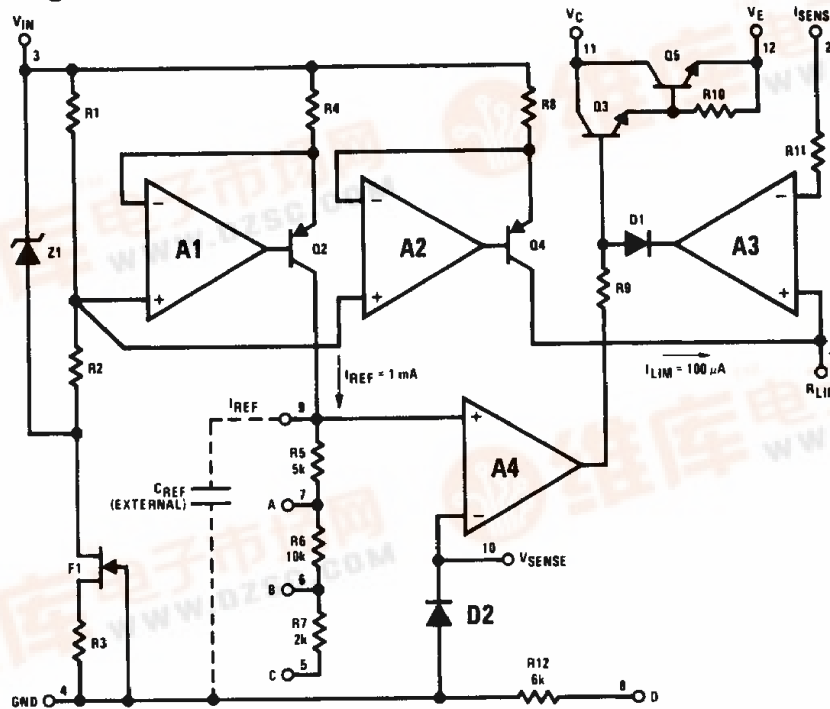

Connection Diagram

TO-8 Metal Can Package

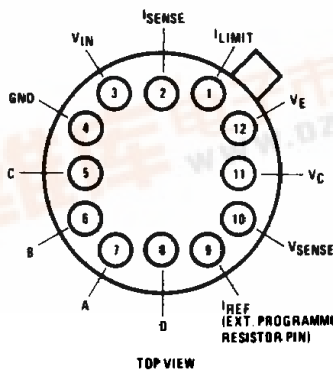

Case is electrically isolated

Typical Applications

Precision 15V Reference Supply without Current Limit

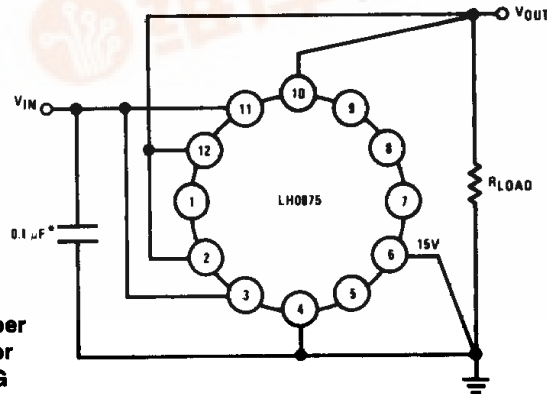

*Needed if device is far from filter capacitors

Order Number
LH0075G or
LH0075CG
See NS Package
Number H12B



Absolute Maximum Ratings

If Military/Aerospace specified devices are required, please contact the National Semiconductor Sales Office/Distributors for availability and specifications.

(Note 4)

Input Voltage	32V
Output Voltage	27V
Output Current	200 mA
Power Dissipation	See Curve

Operating Temperature Range

LH0075 -55°C to +125°C

LH0075C 0°C to +70°C

Storage Temperature -65°C to +150°C

Lead Temp. (Soldering, 10 seconds) 300°C

Electrical Characteristics

Conditions for $T_{MIN} \leq T_A \leq T_{MAX}$ unless otherwise noted

Parameter	Conditions	LH0075			LH0075C			Units
		Min	Typ	Max	Min	Typ	Max	
Line Regulation	$T_A = 25^\circ\text{C}$		0.008	0.02		0.008	0.04	%/V
Load Regulation	$T_A = 25^\circ\text{C}$, $1\text{ mA} < I_{LOAD} < 200\text{ mA}$ $V_{OUT} \leq 5.0\text{V}$ $V_{OUT} \geq 5.0\text{V}$		2.5 0.055	7.5 0.15		2.5 0.055	15 0.3	mV %
Reference Current (I_{REF})	$T_A = 25^\circ\text{C}$, $V_{IN} = 15\text{V}$	0.998	1.000	1.002	0.995	1.00	1.005	mA
Load Regulation	$1\text{ mA} < I_{LOAD} < 200\text{ mA}$ $V_{OUT} \leq 5.0\text{V}$ $V_{OUT} \geq 5.0\text{V}$		4.0 0.075	15 0.3		4.0 0.075	25 0.5	mV %
Reference Current Drift ($\Delta I_{REF}/\Delta\text{Temp.}$)	$V_{IN} = 15\text{V}$		-0.0065			-0.0065		%/°C
Minimum Load Current (I_{LIM})	(Note 1)	98	100	102	95	100	105	μA
Output Voltage Range		0		27	0		27	V
Minimum Input Voltage		10			10			V
Input-Output Differential Voltage	$T_A = 25^\circ\text{C}$, $1\text{ mA} < I_{LOAD} < 200\text{ mA}$		3.0	3.2		3.0	3.5	V
Quiescent Supply Current	$V_{IN} = 15\text{V}$		6.0	8.0		6.5	10	mA
Ripple Rejection	$V_{OUT} = 5.0\text{V}$, $f = 120\text{ Hz}$ $C_{REF} = 2.2\ \mu\text{F}$		65 80			65 80		dB dB
Output Voltage Tolerance	$T_A = 25^\circ\text{C}$ (Note 2)		± 0.1	± 0.5		± 0.1	± 1.0	%
Output Voltage Change with Temperature ($\Delta V_{OUT}/\Delta\text{Temp.}$)	(Note 3)		0.003			0.003		%/°C

Note 1: Minimum load current is established by I_{LIM} , the current from Q4 (see schematic). I_{LIM} goes directly to the output if the current limit feature is used.

Note 2: For $V_{IN} = 15\text{V}$ and V_{OUT} obtained by using R5, R6, R7, and R12 individually.

Note 3: Total change over specified temperature range.

Note 4: Refer to RETS075G drawing for military specifications on the LN0075.

Typical Performance Characteristics

Maximum Power Dissipation

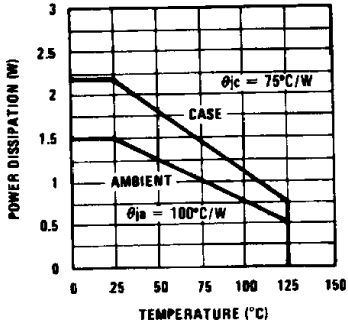

Reference Current Change with Temperature (Normalized)

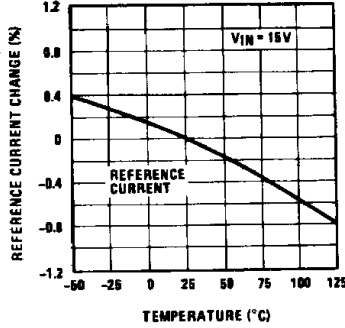

Temperature Stability

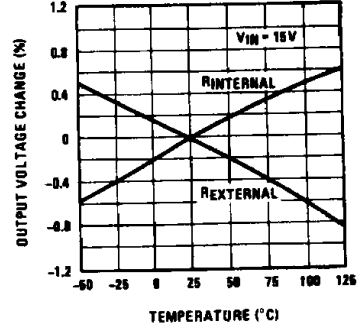

Output Voltage Change with Temperature (Normalized)

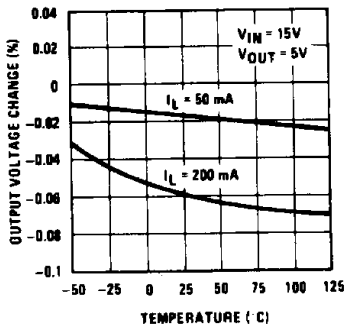

Current Limit

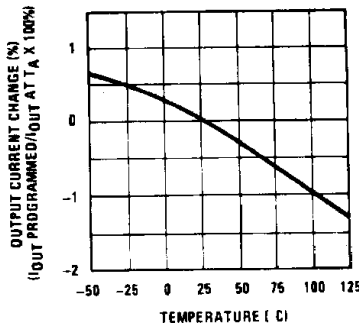

Input-Output Differential Voltage

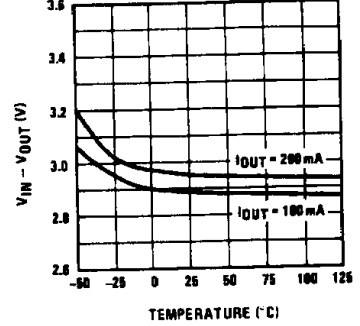

Load Transient Response (Voltage Mode)

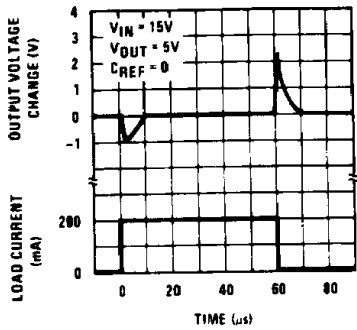

Load Transient Response (Current Mode)

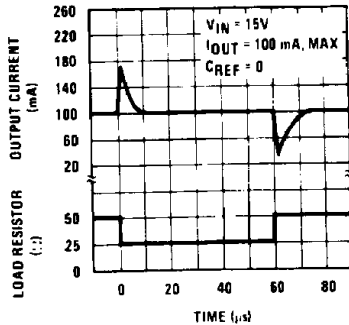

Ripple Rejection

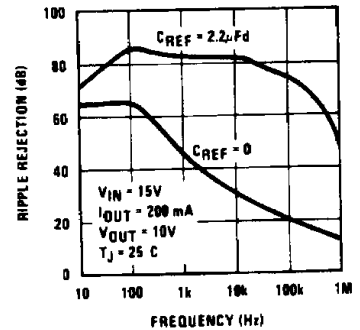

Line Transient Response

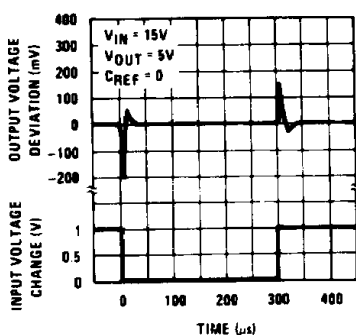

Line Transient Response

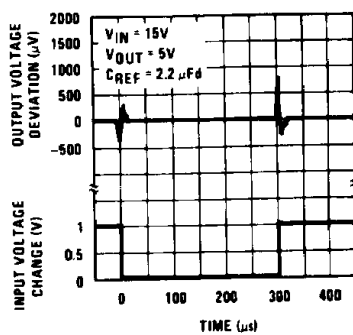

Output Impedance

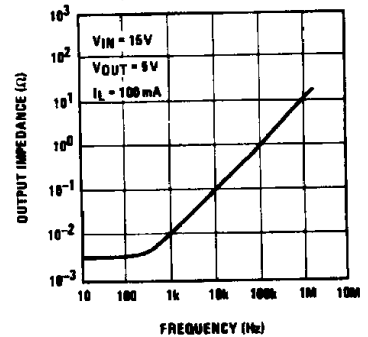

Typical Applications (Continued)

2A Regulator with Current Limit

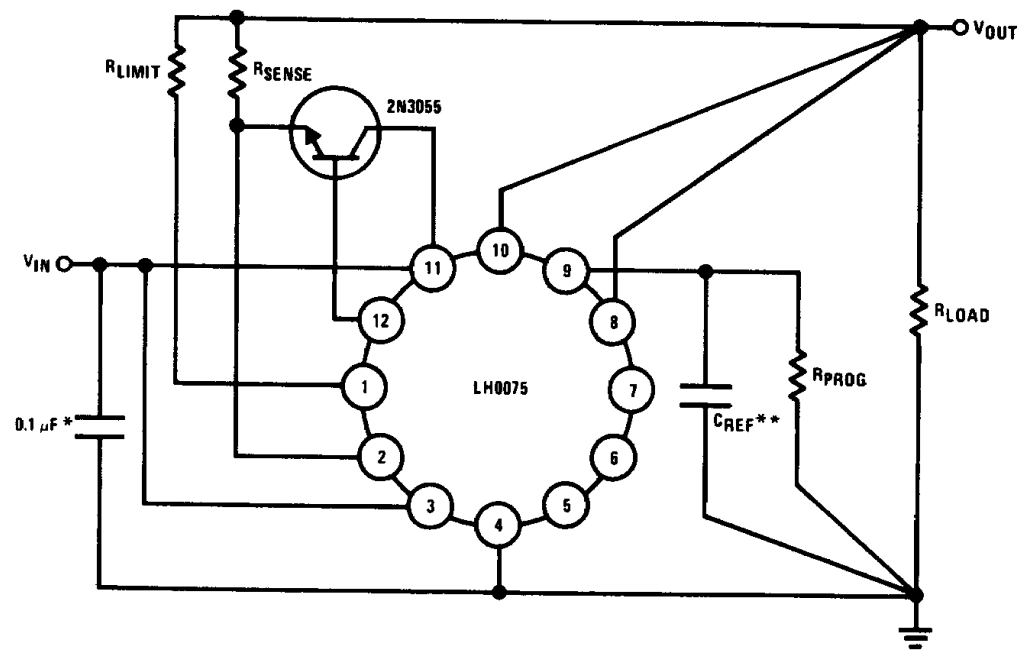

Variable Voltage Reference with Current Limit

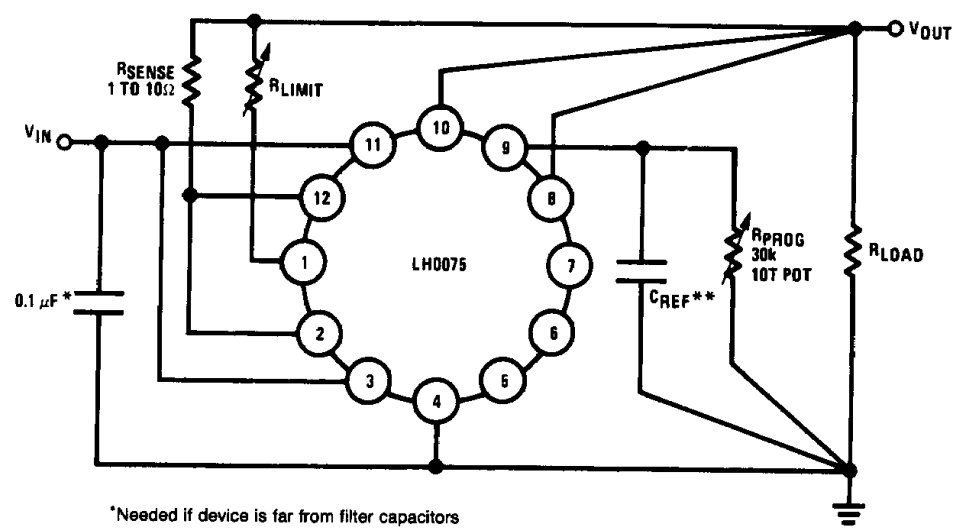

*Needed if device is far from filter capacitors
 **Optional—improves transient response

TL/H/5549-3

$$R_{PROG} = \frac{V_{OUT \text{ Desired}}}{1 \text{ mA}}$$

$$I_{OUT(MAX)} = \left[\frac{R_{LIMIT}}{R_{SENSE}} + 1 \right] \times 100 \mu A$$

$$I_{OUT} \leq 200 \text{ mA}$$

Applications Information

The LH0075 does not require capacitors for stable operation, but an input bypass is recommended if device is far

from filter capacitors. A 0.1 μF for input bypassing should be adequate for almost all applications.



Applications Information (Continued)

DESCRIPTION OF OPTIONS

Ripple Rejection Compensation. (Increases Ripple Rejection Typically to 80 dB)

The ripple rejection may be improved by connecting an external capacitor between pin 9 and ground. (The typical performance curves show the rejection with a capacitance of 2.2 μ Fd.)

Internal Voltage Programming

The LM0075 provides various precision output voltages simply by using one or more of the internal resistors. A particular voltage may be obtained by external connections as shown in Table I.

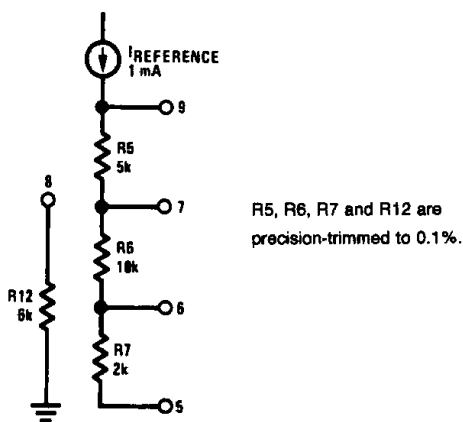

FIGURE 1

External Voltage Programming

An external resistance can be connected between pin 9 and ground to obtain any voltage from 0 to 27V using the following equation:

$$R_{EXT} = \frac{V_{OUT \text{ Desired}}}{1 \text{ mA}}$$

The reference current (I_{REF}) has a typical temperature coefficient of $-65 \text{ ppm}/^\circ\text{C}$. Choosing a resistive material with a temperature coefficient of $65 \text{ ppm}/^\circ\text{C}$ will compensate the negative temperature coefficient, resulting in an output voltage with minimal change over the operating temperature range. Example of a good resistive material is Nichrome, which has a typical temperature coefficient of $80 \text{ ppm}/^\circ\text{C}$.

TABLE I. Connection Scheme for Internal Available Output Voltages

OUTPUT VOLTAGE (V)	PIN 5	PIN 6	PIN 7	PIN 8	PIN 9
5			Gnd		
6				-----	
8	-----			-----	
10		Gnd	-----	-----	
12	Gnd		-----	-----	
15		Gnd		-----	
18	-----		-----	-----	

Since a current source is used as a reference, this makes remote voltage programming possible.

Current Limit Programming

The maximum current output of the device may be limited by adding two external resistors as shown below. The resistor values are easily calculated with the following equation:

$$I_{OUT(MAX)} = \left[\frac{R_{LIMIT}}{R_{SENSE}} + 1 \right] \times 100 \mu\text{A}$$

where $R_{SENSE} = 1 \text{ to } 10 \Omega$

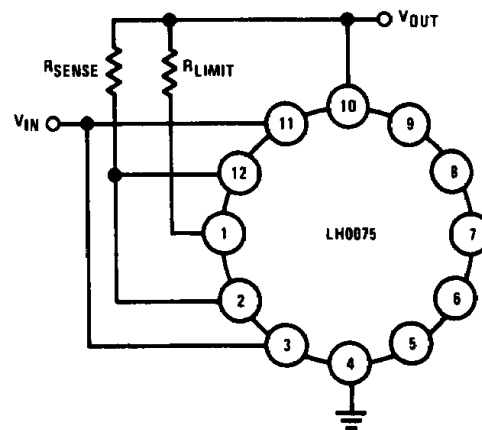

TL/H/5549-5

FIGURE 2. Current Limit Programming

This programmable current limit feature can be extended to make the LH0075 a programmable constant current source. This can be done by leaving pin 9 open and setting R_{LIMIT} and R_{SENSE} as desired.

For applications where the current limit is used, a minimum load current of $100 \mu\text{A}$ is established at the output. This arises from the fact that the constant current used in setting maximum output current is $100 \mu\text{A}$, and it goes directly to the output of the LH0075. If the total current drawn from the output is less than the minimum, the output will rise.

As in the remote voltage adjustment application, remote current sensing can be applied similarly. R_{SENSE} must be placed as close to the output of the LH0075 as possible, but R_{LIMIT} can be a fixed resistor or potentiometer located remotely from the device.