

# LH168M

## 384-output TFT-LCD Source Driver IC

### DESCRIPTION

The LH168M is a 384-output TFT-LCD source driver IC which can simultaneously display 262 144 colors in 64 gray scales.

### FEATURES

- Number of LCD drive outputs : 384
- Built-in 6-bit digital input DAC
- Dot-inversion drive : Outputs the inverted gray scale voltages between LCD drive pins next to each other
- RSDS™\*(Reduced Swing Differential Signaling) input interface (Data and CK) : Possible to reduce Electro-Magnetic Interference (EMI)
- Possible to display 262 144 colors in 64 gray scales with reference voltage input of 18 gray scales : This reference voltage input corresponds to  $\gamma$  correction and intermediate reference voltage input can be abbreviated
- Cascade connection
- Sampling sequence :  
Output shift direction can be selected  
XO<sub>1</sub>, YO<sub>1</sub>, ZO<sub>1</sub>→XO<sub>128</sub>, YO<sub>128</sub>, ZO<sub>128</sub> or  
ZO<sub>128</sub>, YO<sub>128</sub>, XO<sub>128</sub>→ZO<sub>1</sub>, YO<sub>1</sub>, XO<sub>1</sub>
- Shift clock frequency : 68 MHz (MAX.)
- Supply voltages
  - V<sub>CC</sub> (for logic system) : +3.0 to +3.6 V
  - V<sub>L</sub>s (for LCD drive system) : +12 V (MAX.)
- Package : 434-pin TCP (Tape Carrier Package)

\* RSDS is a trademark of National Semiconductor Corporation.  
SHARP recommends FPD87310 of National Semiconductor Corporation as a timing controller for RSDS™.

### PIN CONNECTIONS

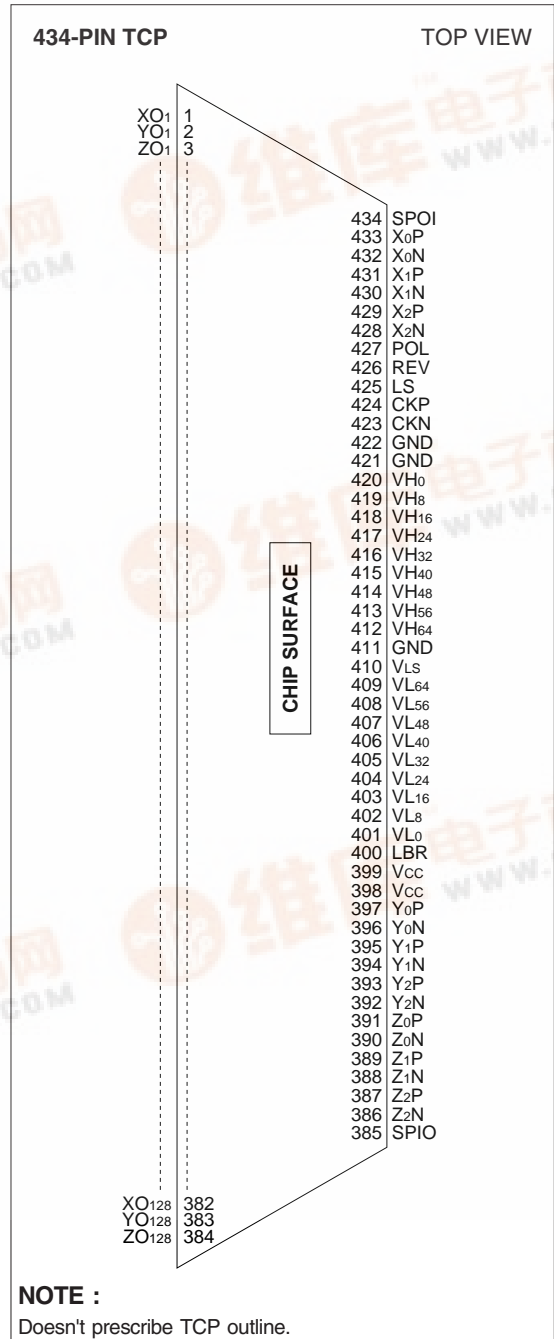

**PIN DESCRIPTION**

<b>PIN NO.</b>	<b>SYMBOL</b>	<b>I/O</b>	<b>DESCRIPTION</b>
1 to 384	XO <sub>1</sub> -ZO <sub>128</sub>	O	LCD drive output pins
385	SPIO	I/O	Start pulse input/cascade output pin
386 to 391	Z <sub>2</sub> N-Z <sub>0</sub> P	I	Data input pins
392 to 397	Y <sub>2</sub> N-Y <sub>0</sub> P	I	Data input pins
398, 399	V <sub>CC</sub>	–	Power supply pins for digital circuit
400	LBR	I	Shift direction selection input pin
401 to 409	VL <sub>0</sub> -VL <sub>64</sub>	I	Reference voltage input pins
410	V <sub>LS</sub>	–	Power supply pin for analog circuit
411, 421, 422	GND	–	Ground pins
412 to 420	VH <sub>64</sub> -VH <sub>0</sub>	I	Reference voltage input pins
423, 424	CKN, CKP	I	Shift clock input pins
425	LS	I	Latch input pin
426	REV	I	LCD drive output polarity exchange input pin
427	POL	I	Input data polarity exchange input pin
428 to 433	X <sub>2</sub> N-X <sub>0</sub> P	I	Data input pins
434	SPOI	I/O	Start pulse input/cascade output pin

BLOCK DIAGRAM

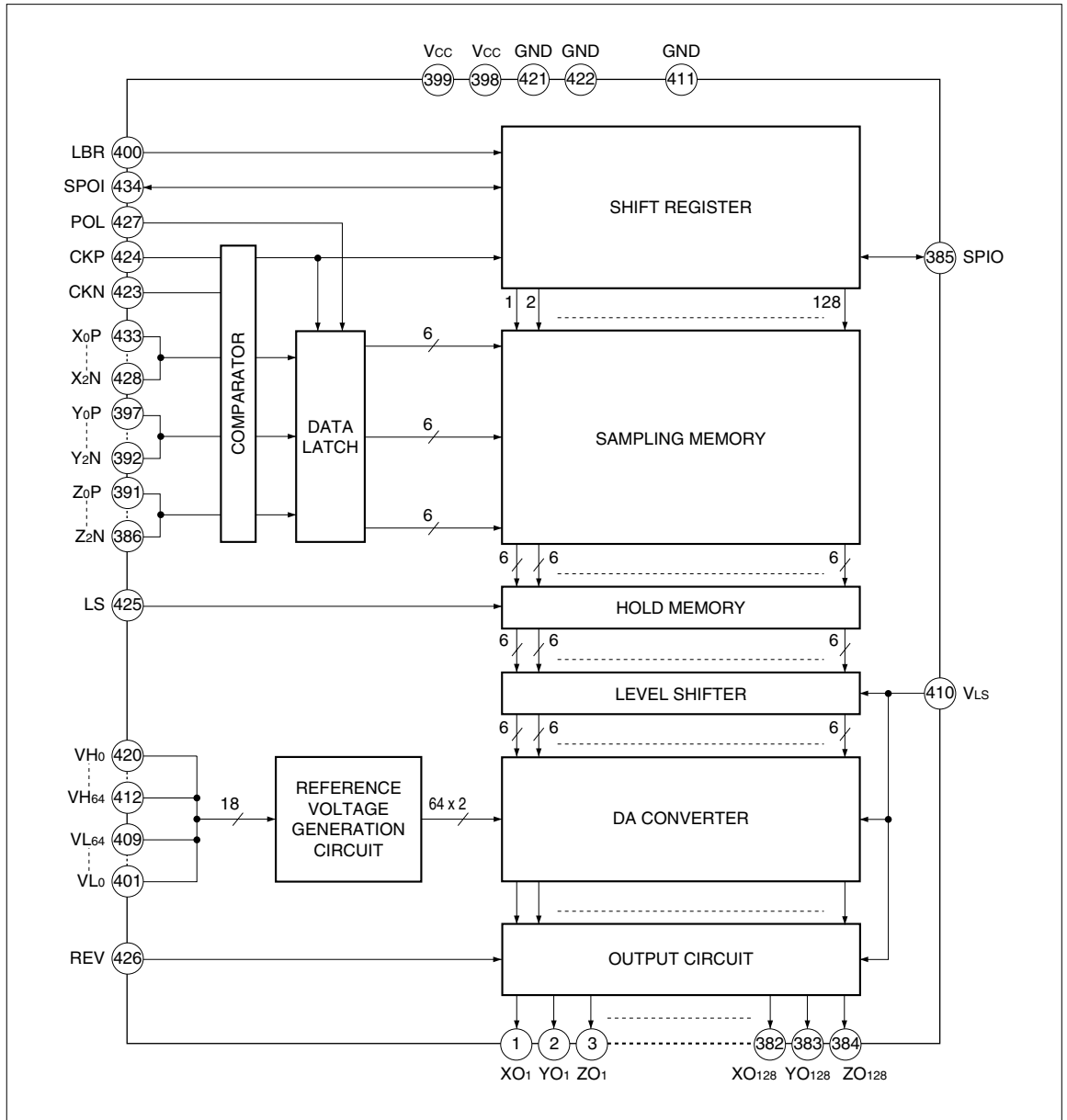

**FUNCTIONAL OPERATIONS OF EACH BLOCK**

BLOCK	FUNCTION
Shift Register	Used as a bi-directional shift register which performs the shifting operation by CK and selects bits for data sampling.
Data Latch	Used to temporary latch the input data which is sent to the sampling memory.
Comparator	Convert low voltage input signal into internal [CMOS level] voltage input signal.
Sampling Memory	Used to sample the data to be entered by time sharing.
Hold Memory	Used for latch processing of data in the sampling memory by LS input.
Level Shifter	Used to shift the data in the hold memory to the power supply level of the analog circuit unit and sends the shifted data to DA converter.
Reference Voltage Generation Circuit	Used to generate a gamma-connected 64 x 2-level voltage by the resistor dividing circuit.
DA Converter	Used to generate an analog signal according to the display data and sends the signal to the output circuit.
Output Circuit	Used as a voltage follower, configured with an operational amplifier and an output buffer, which outputs analog signals of 64 x 2 gray scales to LCD drive output pin.

**INPUT/OUTPUT CIRCUITS**

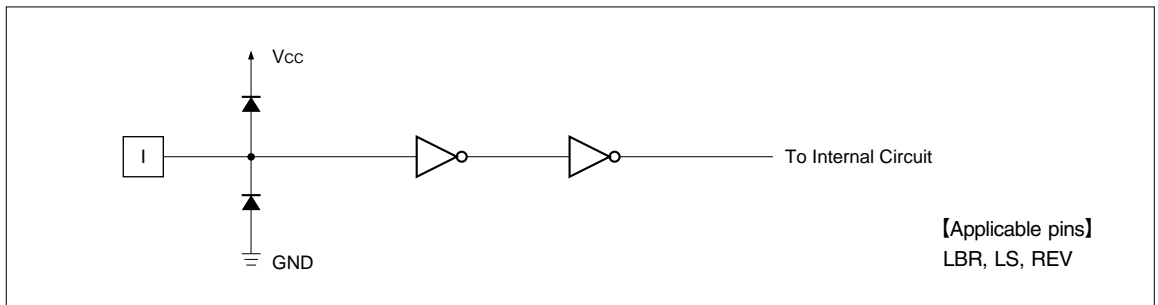

**Fig. 1 Input Circuit (1)**

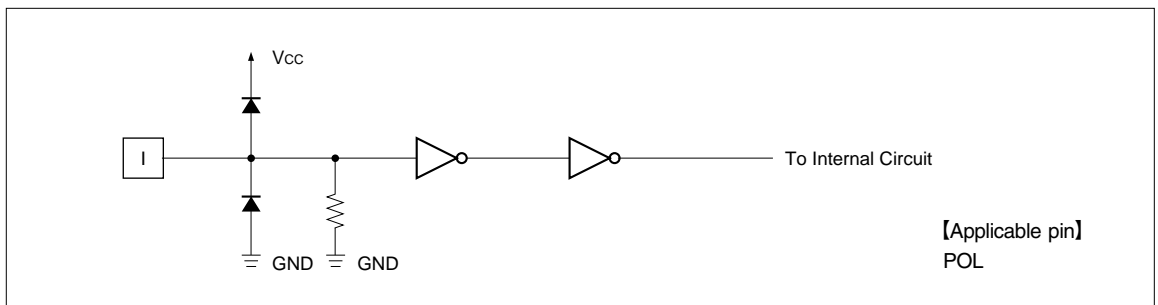

**Fig. 2 Input Circuit (2)**

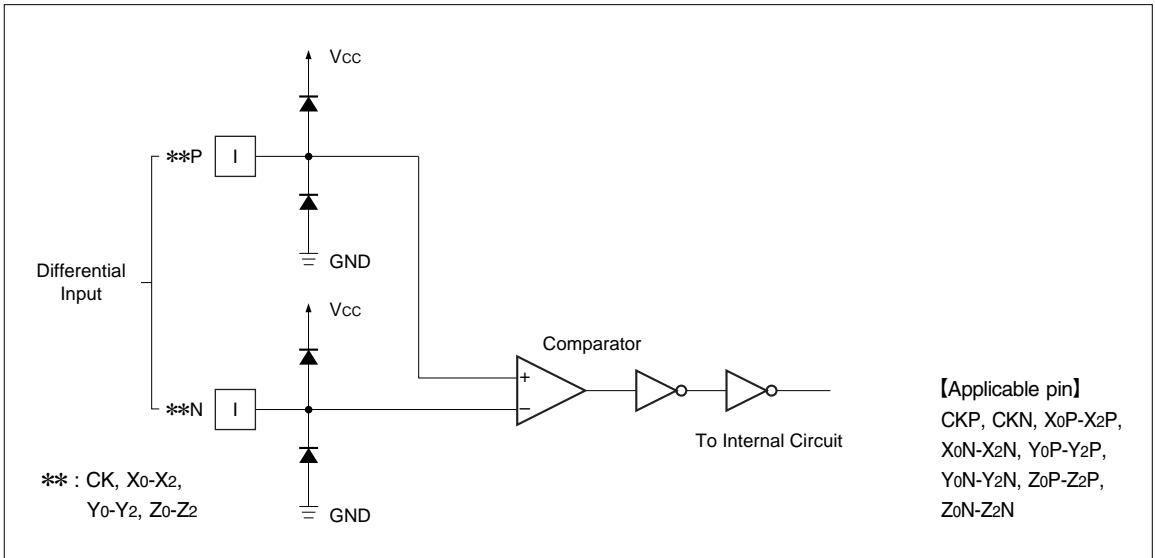

Fig. 3 Input Circuit (3)

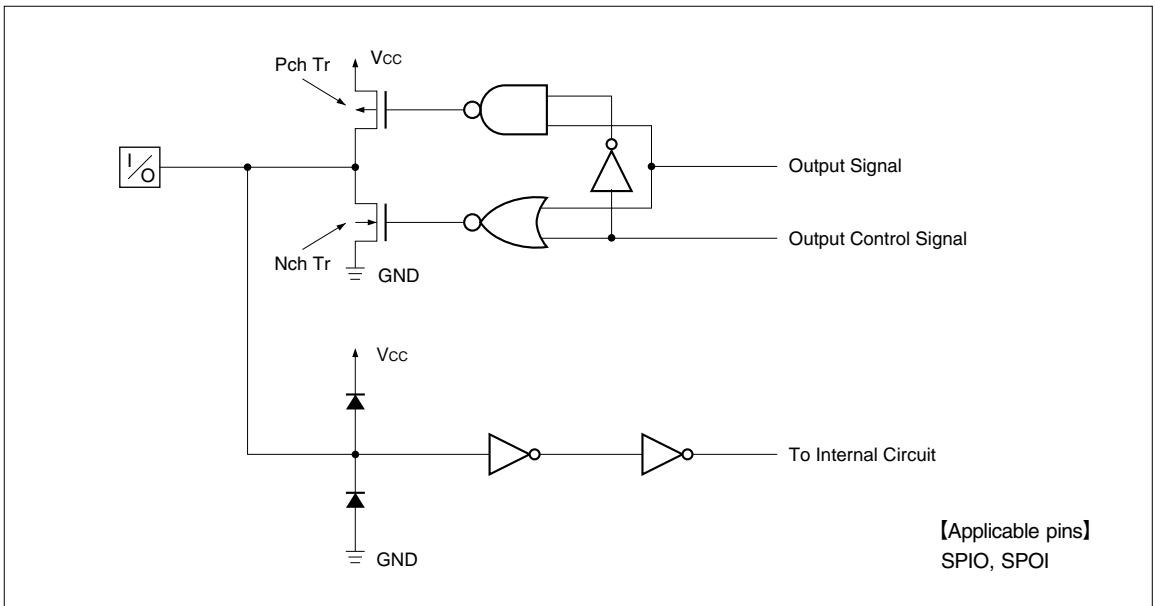

Fig. 4 Input/Output Circuit

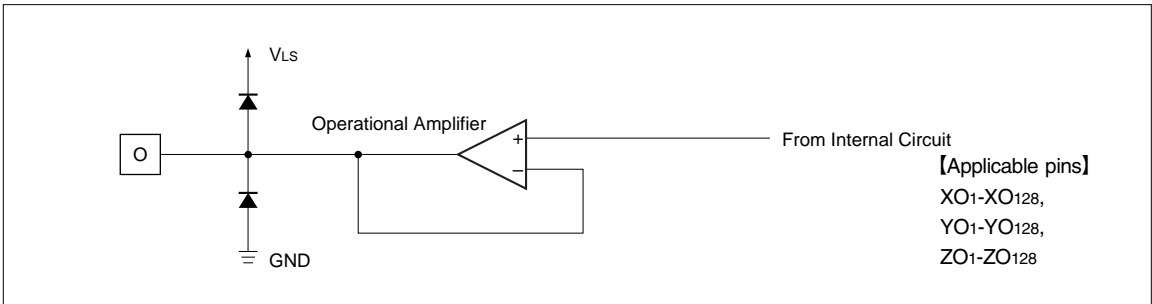

Fig. 5 Output Circuit

## FUNCTIONAL DESCRIPTION

### Pin Functions

SYMBOL	FUNCTIONS
Vcc	Used as power supply pin for digital circuit, connected to +3.0 to +3.6 V.
VLS	Used as power supply pin for analog circuit, connected to +8.0 to +12.0 V.
GND	Used as ground pin, connected to 0 V.
SPIO SPOI	Used as input pins of start pulse and also used as output pins for cascade connection. When "H" is input into start pulse input pin, data sampling is started. On completion of sampling, "H" pulse is output to output pin for cascade connection. Pin functions are selected by LBR. For selecting, refer to <b>"Functional Operations"</b> .
LBR	Used as input pin for selecting the shift register direction. For selecting, refer to <b>"Functional Operations"</b> .
LS	Used as input pin for parallel transfer from sampling memory to hold memory. Data is transferred at the rising edge and output from LCD drive output pin.
CKP CKN	Used as shift clock input pin. Data is latched into sampling memory from data input pin at the falling edge and the rising edge. (Use RSDS input voltage : 0 V to Vcc - 1.0 V)
VH0-VH64 VL0-VL64	Used as reference voltage input pins. Hold the reference voltage fixed during the period of LCD drive output. For relation between input data and output voltage values, refer to <b>"Output Voltage Value"</b> . For internal gamma correction, refer to <b>"Gamma Correction Value"</b> . Observe the following relation for input voltage. $VLS > VH_0 \geq VH_8 \geq \dots \geq VH_{64} \geq VL_{64} \geq VL_{56} \geq \dots \geq VL_0 > GND$ .
X0P-X2N Y0P-Y2N Z0P-Z2N	Used as data input pins of R, G, and B colors. 3-bit data are input from data pins at the falling edge and the rising edge of CKP (CKN). For relation between input data and output voltage values, refer to <b>"Functional Operations"</b> and <b>"Output Voltage Value"</b> . Select the data to be entered into X, Y, and Z according to picture element arrays of the panel.
XO1-XO128, YO1-YO128, ZO1-ZO128	Used as LCD drive output pins which output the voltage corresponding to the input of data input pins (X0P to X2N, Y0P to Y2N, Z0P to Z2N). Data of XO1 to XO128 correspond to X0P to X2N. Data of YO1 to YO128 correspond to Y0P to Y2N, and data of ZO1 to ZO128 correspond to Z0P to Z2N. For relation between input data and output voltage values, refer to <b>"Functional Operations"</b> and <b>"Output Voltage Value"</b> .

SYMBOL	FUNCTIONS
POL	Used as input pin for input data polarity exchange. When "L" is entered, display data becomes normal mode. When "H" is entered, input data becomes polarity exchange mode. For relation between input data and output voltage value, refer to " <b>Output Voltage Value</b> ". These pins are pulled down at the inside.
REV	Used as polarity exchange pin of LCD drive output. Data is taken at the term when LS is "H" and the output polarity of LCD drive output pin is determined. For exchanging, refer to " <b>Output Characteristics</b> ".

## Functional Operations

The following describes the relation between data input pin and output direction.

Data input pin	X <sub>0P</sub> -X <sub>2N</sub>	Y <sub>0P</sub> -Y <sub>2N</sub>	Z <sub>0P</sub> -Z <sub>2N</sub>	.....	X <sub>0P</sub> -X <sub>2N</sub>	Y <sub>0P</sub> -Y <sub>2N</sub>	Z <sub>0P</sub> -Z <sub>2N</sub>
Output direction	XO <sub>1</sub>	YO <sub>1</sub>	ZO <sub>1</sub>	.....	XO <sub>128</sub>	YO <sub>128</sub>	ZO <sub>128</sub>

The following describes the relation between LBR pin, SPOI pin, SPIO pin and output direction

PIN	OUTPUT DIRECTION	
	RIGHT SHIFT (X <sub>01</sub> , Y <sub>01</sub> , Z <sub>01</sub> → X <sub>0128</sub> , Y <sub>0128</sub> , Z <sub>0128</sub> )	LEFT SHIFT (Z <sub>0128</sub> , Y <sub>0128</sub> , X <sub>0128</sub> → Z <sub>01</sub> , Y <sub>01</sub> , X <sub>01</sub> )
LBR	H	L
SPOI	Input	Output
SPIO	Output	Input

### NOTE :

Color data corresponding to X, Y, and Z vary depending on the output direction.

## Output Characteristics

The following describes the relation between REV pin and output polarity of LCD drive pin.

REV	"H"	"L"
XO <sub>1</sub>	+	-
YO <sub>1</sub>	-	+
ZO <sub>1</sub>	+	-
XO <sub>2</sub>	-	+
YO <sub>2</sub>	+	-
ZO <sub>2</sub>	-	+
XO <sub>3</sub>	+	-
YO <sub>3</sub>	-	+
ZO <sub>3</sub>	+	-
XO <sub>4</sub>	-	+
YO <sub>4</sub>	+	-
ZO <sub>4</sub>	-	+
:	:	:
XO <sub>125</sub>	+	-
YO <sub>125</sub>	-	+
ZO <sub>125</sub>	+	-
XO <sub>126</sub>	-	+
YO <sub>126</sub>	+	-
ZO <sub>126</sub>	-	+
XO <sub>127</sub>	+	-
YO <sub>127</sub>	-	+
ZO <sub>127</sub>	+	-
XO <sub>128</sub>	-	+
YO <sub>128</sub>	+	-
ZO <sub>128</sub>	-	+

### NOTES :

- + : The gray scale voltages corresponding to reference voltage VH<sub>0</sub> to VH<sub>64</sub> are outputs.
- : The gray scale voltages corresponding to reference voltage VL<sub>0</sub> to VL<sub>64</sub> are outputs.

### Timing Diagram

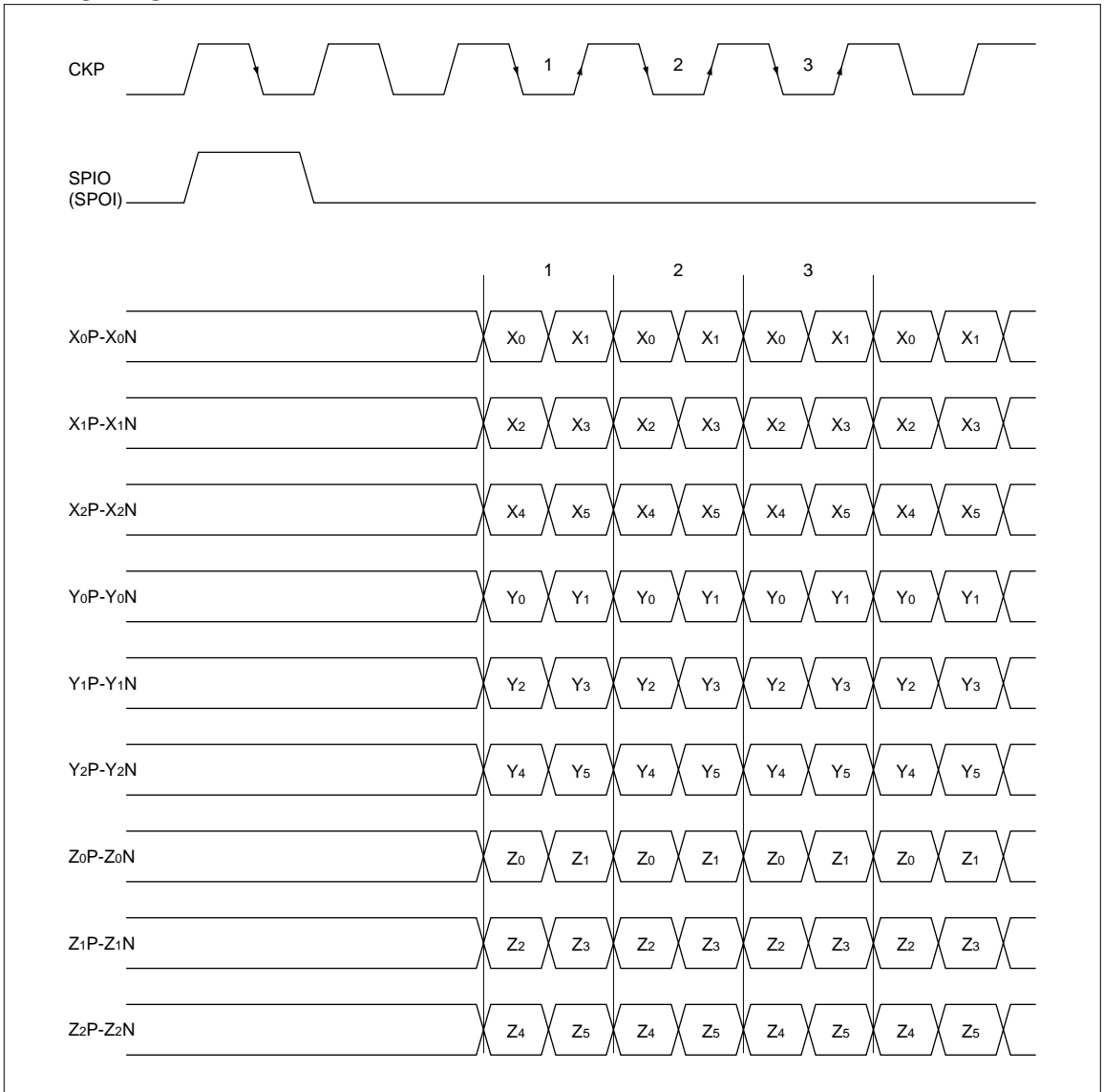

## Output Voltage Value

Two voltages are selected from all of the reference voltages (V<sub>0</sub>-V<sub>64</sub>) by the upper 3-bit data (D<sub>5</sub>, D<sub>4</sub> and D<sub>3</sub>) of the 6-bit input data (D<sub>5</sub>, D<sub>4</sub>, D<sub>3</sub>, D<sub>2</sub>, D<sub>1</sub> and D<sub>0</sub>) taken by time sharing, and intermediate value is determined by the lower 3-bit data (D<sub>2</sub>, D<sub>1</sub>

and D<sub>0</sub>). The V<sub>i</sub> is a reference voltage (VH<sub>i</sub> or VL<sub>i</sub>) that is determined by the polarity exchange input (REV). Relation between input data and output voltage values is shown below.

(i = 0, 8, 16, 24, 32, 40, 48, 56, 64)

(1) Output voltage when reference voltage is VH<sub>0</sub> to VH<sub>64</sub>.

INPUT DATA	OUTPUT VOLTAGE		INPUT DATA	OUTPUT VOLTAGE	
	POL = "L"	POL = "H"		POL = "L"	POL = "H"
0	VH <sub>0</sub>	VH <sub>64</sub> + (VH <sub>56</sub> - VH <sub>64</sub> ) x 1/8	20	VH <sub>32</sub>	VH <sub>32</sub> + (VH <sub>24</sub> - VH <sub>32</sub> ) x 1/8
1	VH <sub>8</sub> + (VH <sub>0</sub> - VH <sub>8</sub> ) x 7/8	VH <sub>64</sub> + (VH <sub>56</sub> - VH <sub>64</sub> ) x 2/8	21	VH <sub>40</sub> + (VH <sub>32</sub> - VH <sub>40</sub> ) x 7/8	VH <sub>32</sub> + (VH <sub>24</sub> - VH <sub>32</sub> ) x 2/8
2	VH <sub>8</sub> + (VH <sub>0</sub> - VH <sub>8</sub> ) x 6/8	VH <sub>64</sub> + (VH <sub>56</sub> - VH <sub>64</sub> ) x 3/8	22	VH <sub>40</sub> + (VH <sub>32</sub> - VH <sub>40</sub> ) x 6/8	VH <sub>32</sub> + (VH <sub>24</sub> - VH <sub>32</sub> ) x 3/8
3	VH <sub>8</sub> + (VH <sub>0</sub> - VH <sub>8</sub> ) x 5/8	VH <sub>64</sub> + (VH <sub>56</sub> - VH <sub>64</sub> ) x 4/8	23	VH <sub>40</sub> + (VH <sub>32</sub> - VH <sub>40</sub> ) x 5/8	VH <sub>32</sub> + (VH <sub>24</sub> - VH <sub>32</sub> ) x 4/8
4	VH <sub>8</sub> + (VH <sub>0</sub> - VH <sub>8</sub> ) x 4/8	VH <sub>64</sub> + (VH <sub>56</sub> - VH <sub>64</sub> ) x 5/8	24	VH <sub>40</sub> + (VH <sub>32</sub> - VH <sub>40</sub> ) x 4/8	VH <sub>32</sub> + (VH <sub>24</sub> - VH <sub>32</sub> ) x 5/8
5	VH <sub>8</sub> + (VH <sub>0</sub> - VH <sub>8</sub> ) x 3/8	VH <sub>64</sub> + (VH <sub>56</sub> - VH <sub>64</sub> ) x 6/8	25	VH <sub>40</sub> + (VH <sub>32</sub> - VH <sub>40</sub> ) x 3/8	VH <sub>32</sub> + (VH <sub>24</sub> - VH <sub>32</sub> ) x 6/8
6	VH <sub>8</sub> + (VH <sub>0</sub> - VH <sub>8</sub> ) x 2/8	VH <sub>64</sub> + (VH <sub>56</sub> - VH <sub>64</sub> ) x 7/8	26	VH <sub>40</sub> + (VH <sub>32</sub> - VH <sub>40</sub> ) x 2/8	VH <sub>32</sub> + (VH <sub>24</sub> - VH <sub>32</sub> ) x 7/8
7	VH <sub>8</sub> + (VH <sub>0</sub> - VH <sub>8</sub> ) x 1/8	VH <sub>56</sub>	27	VH <sub>40</sub> + (VH <sub>32</sub> - VH <sub>40</sub> ) x 1/8	VH <sub>24</sub>
8	VH <sub>8</sub>	VH <sub>56</sub> + (VH <sub>48</sub> - VH <sub>56</sub> ) x 1/8	28	VH <sub>40</sub>	VH <sub>24</sub> + (VH <sub>16</sub> - VH <sub>24</sub> ) x 1/8
9	VH <sub>16</sub> + (VH <sub>8</sub> - VH <sub>16</sub> ) x 7/8	VH <sub>56</sub> + (VH <sub>48</sub> - VH <sub>56</sub> ) x 2/8	29	VH <sub>48</sub> + (VH <sub>40</sub> - VH <sub>48</sub> ) x 7/8	VH <sub>24</sub> + (VH <sub>16</sub> - VH <sub>24</sub> ) x 2/8
A	VH <sub>16</sub> + (VH <sub>8</sub> - VH <sub>16</sub> ) x 6/8	VH <sub>56</sub> + (VH <sub>48</sub> - VH <sub>56</sub> ) x 3/8	2A	VH <sub>48</sub> + (VH <sub>40</sub> - VH <sub>48</sub> ) x 6/8	VH <sub>24</sub> + (VH <sub>16</sub> - VH <sub>24</sub> ) x 3/8
B	VH <sub>16</sub> + (VH <sub>8</sub> - VH <sub>16</sub> ) x 5/8	VH <sub>56</sub> + (VH <sub>48</sub> - VH <sub>56</sub> ) x 4/8	2B	VH <sub>48</sub> + (VH <sub>40</sub> - VH <sub>48</sub> ) x 5/8	VH <sub>24</sub> + (VH <sub>16</sub> - VH <sub>24</sub> ) x 4/8
C	VH <sub>16</sub> + (VH <sub>8</sub> - VH <sub>16</sub> ) x 4/8	VH <sub>56</sub> + (VH <sub>48</sub> - VH <sub>56</sub> ) x 5/8	2C	VH <sub>48</sub> + (VH <sub>40</sub> - VH <sub>48</sub> ) x 4/8	VH <sub>24</sub> + (VH <sub>16</sub> - VH <sub>24</sub> ) x 5/8
D	VH <sub>16</sub> + (VH <sub>8</sub> - VH <sub>16</sub> ) x 3/8	VH <sub>56</sub> + (VH <sub>48</sub> - VH <sub>56</sub> ) x 6/8	2D	VH <sub>48</sub> + (VH <sub>40</sub> - VH <sub>48</sub> ) x 3/8	VH <sub>24</sub> + (VH <sub>16</sub> - VH <sub>24</sub> ) x 6/8
E	VH <sub>16</sub> + (VH <sub>8</sub> - VH <sub>16</sub> ) x 2/8	VH <sub>56</sub> + (VH <sub>48</sub> - VH <sub>56</sub> ) x 7/8	2E	VH <sub>48</sub> + (VH <sub>40</sub> - VH <sub>48</sub> ) x 2/8	VH <sub>24</sub> + (VH <sub>16</sub> - VH <sub>24</sub> ) x 7/8
F	VH <sub>16</sub> + (VH <sub>8</sub> - VH <sub>16</sub> ) x 1/8	VH <sub>48</sub>	2F	VH <sub>48</sub> + (VH <sub>40</sub> - VH <sub>48</sub> ) x 1/8	VH <sub>16</sub>
10	VH <sub>16</sub>	VH <sub>48</sub> + (VH <sub>40</sub> - VH <sub>48</sub> ) x 1/8	30	VH <sub>48</sub>	VH <sub>16</sub> + (VH <sub>8</sub> - VH <sub>16</sub> ) x 1/8
11	VH <sub>24</sub> + (VH <sub>16</sub> - VH <sub>24</sub> ) x 7/8	VH <sub>48</sub> + (VH <sub>40</sub> - VH <sub>48</sub> ) x 2/8	31	VH <sub>56</sub> + (VH <sub>48</sub> - VH <sub>56</sub> ) x 7/8	VH <sub>16</sub> + (VH <sub>8</sub> - VH <sub>16</sub> ) x 2/8
12	VH <sub>24</sub> + (VH <sub>16</sub> - VH <sub>24</sub> ) x 6/8	VH <sub>48</sub> + (VH <sub>40</sub> - VH <sub>48</sub> ) x 3/8	32	VH <sub>56</sub> + (VH <sub>48</sub> - VH <sub>56</sub> ) x 6/8	VH <sub>16</sub> + (VH <sub>8</sub> - VH <sub>16</sub> ) x 3/8
13	VH <sub>24</sub> + (VH <sub>16</sub> - VH <sub>24</sub> ) x 5/8	VH <sub>48</sub> + (VH <sub>40</sub> - VH <sub>48</sub> ) x 4/8	33	VH <sub>56</sub> + (VH <sub>48</sub> - VH <sub>56</sub> ) x 5/8	VH <sub>16</sub> + (VH <sub>8</sub> - VH <sub>16</sub> ) x 4/8
14	VH <sub>24</sub> + (VH <sub>16</sub> - VH <sub>24</sub> ) x 4/8	VH <sub>48</sub> + (VH <sub>40</sub> - VH <sub>48</sub> ) x 5/8	34	VH <sub>56</sub> + (VH <sub>48</sub> - VH <sub>56</sub> ) x 4/8	VH <sub>16</sub> + (VH <sub>8</sub> - VH <sub>16</sub> ) x 5/8
15	VH <sub>24</sub> + (VH <sub>16</sub> - VH <sub>24</sub> ) x 3/8	VH <sub>48</sub> + (VH <sub>40</sub> - VH <sub>48</sub> ) x 6/8	35	VH <sub>56</sub> + (VH <sub>48</sub> - VH <sub>56</sub> ) x 3/8	VH <sub>16</sub> + (VH <sub>8</sub> - VH <sub>16</sub> ) x 6/8
16	VH <sub>24</sub> + (VH <sub>16</sub> - VH <sub>24</sub> ) x 2/8	VH <sub>48</sub> + (VH <sub>40</sub> - VH <sub>48</sub> ) x 7/8	36	VH <sub>56</sub> + (VH <sub>48</sub> - VH <sub>56</sub> ) x 2/8	VH <sub>16</sub> + (VH <sub>8</sub> - VH <sub>16</sub> ) x 7/8
17	VH <sub>24</sub> + (VH <sub>16</sub> - VH <sub>24</sub> ) x 1/8	VH <sub>40</sub>	37	VH <sub>56</sub> + (VH <sub>48</sub> - VH <sub>56</sub> ) x 1/8	VH <sub>8</sub>
18	VH <sub>24</sub>	VH <sub>40</sub> + (VH <sub>32</sub> - VH <sub>40</sub> ) x 1/8	38	VH <sub>56</sub>	VH <sub>8</sub> + (VH <sub>0</sub> - VH <sub>8</sub> ) x 1/8
19	VH <sub>32</sub> + (VH <sub>24</sub> - VH <sub>32</sub> ) x 7/8	VH <sub>40</sub> + (VH <sub>32</sub> - VH <sub>40</sub> ) x 2/8	39	VH <sub>64</sub> + (VH <sub>56</sub> - VH <sub>64</sub> ) x 7/8	VH <sub>8</sub> + (VH <sub>0</sub> - VH <sub>8</sub> ) x 2/8
1A	VH <sub>32</sub> + (VH <sub>24</sub> - VH <sub>32</sub> ) x 6/8	VH <sub>40</sub> + (VH <sub>32</sub> - VH <sub>40</sub> ) x 3/8	3A	VH <sub>64</sub> + (VH <sub>56</sub> - VH <sub>64</sub> ) x 6/8	VH <sub>8</sub> + (VH <sub>0</sub> - VH <sub>8</sub> ) x 3/8
1B	VH <sub>32</sub> + (VH <sub>24</sub> - VH <sub>32</sub> ) x 5/8	VH <sub>40</sub> + (VH <sub>32</sub> - VH <sub>40</sub> ) x 4/8	3B	VH <sub>64</sub> + (VH <sub>56</sub> - VH <sub>64</sub> ) x 5/8	VH <sub>8</sub> + (VH <sub>0</sub> - VH <sub>8</sub> ) x 4/8
1C	VH <sub>32</sub> + (VH <sub>24</sub> - VH <sub>32</sub> ) x 4/8	VH <sub>40</sub> + (VH <sub>32</sub> - VH <sub>40</sub> ) x 5/8	3C	VH <sub>64</sub> + (VH <sub>56</sub> - VH <sub>64</sub> ) x 4/8	VH <sub>8</sub> + (VH <sub>0</sub> - VH <sub>8</sub> ) x 5/8
1D	VH <sub>32</sub> + (VH <sub>24</sub> - VH <sub>32</sub> ) x 3/8	VH <sub>40</sub> + (VH <sub>32</sub> - VH <sub>40</sub> ) x 6/8	3D	VH <sub>64</sub> + (VH <sub>56</sub> - VH <sub>64</sub> ) x 3/8	VH <sub>8</sub> + (VH <sub>0</sub> - VH <sub>8</sub> ) x 6/8
1E	VH <sub>32</sub> + (VH <sub>24</sub> - VH <sub>32</sub> ) x 2/8	VH <sub>40</sub> + (VH <sub>32</sub> - VH <sub>40</sub> ) x 7/8	3E	VH <sub>64</sub> + (VH <sub>56</sub> - VH <sub>64</sub> ) x 2/8	VH <sub>8</sub> + (VH <sub>0</sub> - VH <sub>8</sub> ) x 7/8
1F	VH <sub>32</sub> + (VH <sub>24</sub> - VH <sub>32</sub> ) x 1/8	VH <sub>32</sub>	3F	VH <sub>64</sub> + (VH <sub>56</sub> - VH <sub>64</sub> ) x 1/8	VH <sub>0</sub>

(2) Output voltage when reference voltage is VL0 to VL64.

INPUT DATA	OUTPUT VOLTAGE		INPUT DATA	OUTPUT VOLTAGE	
	POL = "L"	POL = "H"		POL = "L"	POL = "H"
0	VL0	VL64 + (VL56 - VL64) x 1/8	20	VL32	VL32 + (VL24 - VL32) x 1/8
1	VL8 + (VL0 - VL8) x 7/8	VL64 + (VL56 - VL64) x 2/8	21	VL40 + (VL32 - VL40) x 7/8	VL32 + (VL24 - VL32) x 2/8
2	VL8 + (VL0 - VL8) x 6/8	VL64 + (VL56 - VL64) x 3/8	22	VL40 + (VL32 - VL40) x 6/8	VL32 + (VL24 - VL32) x 3/8
3	VL8 + (VL0 - VL8) x 5/8	VL64 + (VL56 - VL64) x 4/8	23	VL40 + (VL32 - VL40) x 5/8	VL32 + (VL24 - VL32) x 4/8
4	VL8 + (VL0 - VL8) x 4/8	VL64 + (VL56 - VL64) x 5/8	24	VL40 + (VL32 - VL40) x 4/8	VL32 + (VL24 - VL32) x 5/8
5	VL8 + (VL0 - VL8) x 3/8	VL64 + (VL56 - VL64) x 6/8	25	VL40 + (VL32 - VL40) x 3/8	VL32 + (VL24 - VL32) x 6/8
6	VL8 + (VL0 - VL8) x 2/8	VL64 + (VL56 - VL64) x 7/8	26	VL40 + (VL32 - VL40) x 2/8	VL32 + (VL24 - VL32) x 7/8
7	VL8 + (VL0 - VL8) x 1/8	VL56	27	VL40 + (VL32 - VL40) x 1/8	VL24
8	VL8	VL56 + (VL48 - VL56) x 1/8	28	VL40	VL24 + (VL16 - VL24) x 1/8
9	VL16 + (VL8 - VL16) x 7/8	VL56 + (VL48 - VL56) x 2/8	29	VL48 + (VL40 - VL48) x 7/8	VL24 + (VL16 - VL24) x 2/8
A	VL16 + (VL8 - VL16) x 6/8	VL56 + (VL48 - VL56) x 3/8	2A	VL48 + (VL40 - VL48) x 6/8	VL24 + (VL16 - VL24) x 3/8
B	VL16 + (VL8 - VL16) x 5/8	VL56 + (VL48 - VL56) x 4/8	2B	VL48 + (VL40 - VL48) x 5/8	VL24 + (VL16 - VL24) x 4/8
C	VL16 + (VL8 - VL16) x 4/8	VL56 + (VL48 - VL56) x 5/8	2C	VL48 + (VL40 - VL48) x 4/8	VL24 + (VL16 - VL24) x 5/8
D	VL16 + (VL8 - VL16) x 3/8	VL56 + (VL48 - VL56) x 6/8	2D	VL48 + (VL40 - VL48) x 3/8	VL24 + (VL16 - VL24) x 6/8
E	VL16 + (VL8 - VL16) x 2/8	VL56 + (VL48 - VL56) x 7/8	2E	VL48 + (VL40 - VL48) x 2/8	VL24 + (VL16 - VL24) x 7/8
F	VL16 + (VL8 - VL16) x 1/8	VL48	2F	VL48 + (VL40 - VL48) x 1/8	VL16
10	VL16	VL48 + (VL40 - VL48) x 1/8	30	VL48	VL16 + (VL8 - VL16) x 1/8
11	VL24 + (VL16 - VL24) x 7/8	VL48 + (VL40 - VL48) x 2/8	31	VL56 + (VL48 - VL56) x 7/8	VL16 + (VL8 - VL16) x 2/8
12	VL24 + (VL16 - VL24) x 6/8	VL48 + (VL40 - VL48) x 3/8	32	VL56 + (VL48 - VL56) x 6/8	VL16 + (VL8 - VL16) x 3/8
13	VL24 + (VL16 - VL24) x 5/8	VL48 + (VL40 - VL48) x 4/8	33	VL56 + (VL48 - VL56) x 5/8	VL16 + (VL8 - VL16) x 4/8
14	VL24 + (VL16 - VL24) x 4/8	VL48 + (VL40 - VL48) x 5/8	34	VL56 + (VL48 - VL56) x 4/8	VL16 + (VL8 - VL16) x 5/8
15	VL24 + (VL16 - VL24) x 3/8	VL48 + (VL40 - VL48) x 6/8	35	VL56 + (VL48 - VL56) x 3/8	VL16 + (VL8 - VL16) x 6/8
16	VL24 + (VL16 - VL24) x 2/8	VL48 + (VL40 - VL48) x 7/8	36	VL56 + (VL48 - VL56) x 2/8	VL16 + (VL8 - VL16) x 7/8
17	VL24 + (VL16 - VL24) x 1/8	VL40	37	VL56 + (VL48 - VL56) x 1/8	VL8
18	VL24	VL40 + (VL32 - VL40) x 1/8	38	VL56	VL8 + (VL0 - VL8) x 1/8
19	VL32 + (VL24 - VL32) x 7/8	VL40 + (VL32 - VL40) x 2/8	39	VL64 + (VL56 - VL64) x 7/8	VL8 + (VL0 - VL8) x 2/8
1A	VL32 + (VL24 - VL32) x 6/8	VL40 + (VL32 - VL40) x 3/8	3A	VL64 + (VL56 - VL64) x 6/8	VL8 + (VL0 - VL8) x 3/8
1B	VL32 + (VL24 - VL32) x 5/8	VL40 + (VL32 - VL40) x 4/8	3B	VL64 + (VL56 - VL64) x 5/8	VL8 + (VL0 - VL8) x 4/8
1C	VL32 + (VL24 - VL32) x 4/8	VL40 + (VL32 - VL40) x 5/8	3C	VL64 + (VL56 - VL64) x 4/8	VL8 + (VL0 - VL8) x 5/8
1D	VL32 + (VL24 - VL32) x 3/8	VL40 + (VL32 - VL40) x 6/8	3D	VL64 + (VL56 - VL64) x 3/8	VL8 + (VL0 - VL8) x 6/8
1E	VL32 + (VL24 - VL32) x 2/8	VL40 + (VL32 - VL40) x 7/8	3E	VL64 + (VL56 - VL64) x 2/8	VL8 + (VL0 - VL8) x 7/8
1F	VL32 + (VL24 - VL32) x 1/8	VL32	3F	VL64 + (VL56 - VL64) x 1/8	VL0

**$\gamma$  (Gamma) Correction Value**

Between reference voltage input pins VH0 and VH64, 64 resistors are connected in series. And between reference voltage input pins VL0 and VL64, 64 resistors are connected in series. No resistor is connected between reference voltage input pins VH64 and VL64.

The  $\gamma$  correction curve is a broken line connected between intermediate voltage inputs (VH8, VH16, VH24, VH32, VH40, VH48, VH56, VL8, VL16, VL24, VL32, VL40, VL48 and VL56). Each  $\gamma$  correction value between the intermediate voltage inputs is divided into 8 parts by the same resistor.

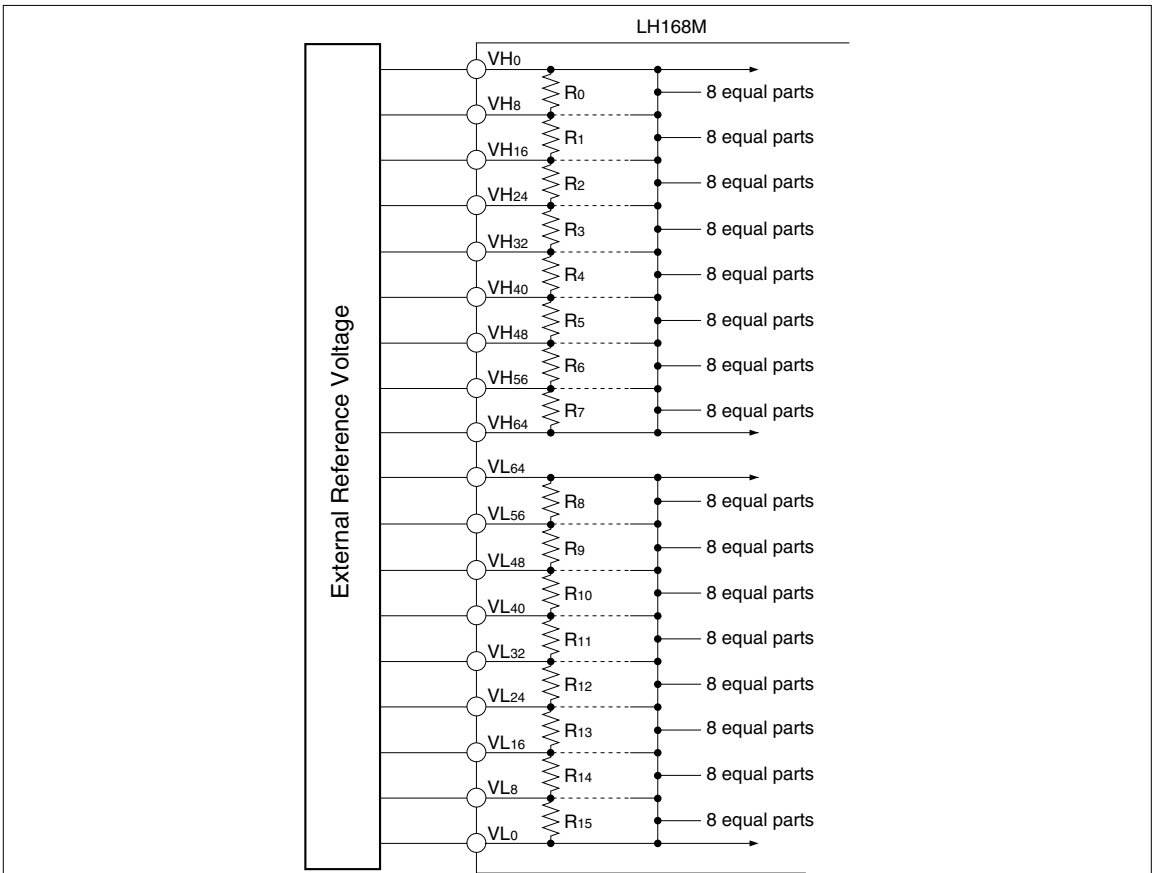

The following shows the ratio of  $\gamma$  correction resistance, when R0 equals 1.

R0	1.00
R1	0.50
R2	0.50
R3	0.50
R4	0.50
R5	0.50
R6	0.50
R7	1.00

R8	1.00
R9	0.50
R10	0.50
R11	0.50
R12	0.50
R13	0.50
R14	0.50
R15	1.00

## PRECAUTIONS

### Precautions when connecting or disconnecting the power supply

This IC has some power supply pins, so it may be permanently damaged by a high current which may flow if voltage is supplied to the LCD drive power supply while the logic system power supply is floating. Therefore, when connecting the power supply, observe the following sequence.

$V_{CC} \rightarrow \text{logic input} \rightarrow V_{LS}, V_{H0}\text{-}V_{H64}, V_{L0}\text{-}V_{L64}$

When disconnecting the power supply, follow the reverse sequence.

### Reference voltage input

The relation of the reference voltage input is shown here.

$V_{LS} > V_{H0} \geq V_{H8} \geq \dots \geq V_{H56} \geq V_{H64} \geq 0.5V_{LS} \geq V_{L64} \geq V_{L56} \geq \dots \geq V_{L8} \geq V_{L0} > \text{GND}$

### Maximum ratings

When connecting or disconnecting the power supply, this IC must be used within the range of the absolute maximum ratings.

### Target output load

This IC is designed for a 150 pF output load capacity. When using this IC for other than 150 pF panels, confirm the device is having no problem before using it.

## ABSOLUTE MAXIMUM RATINGS

PARAMETER	SYMBOL	APPLICABLE PINS	RATING	UNIT	NOTE
Supply voltage	$V_{CC}$	$V_{CC}$	-0.3 to +6.0	V	1, 2
	$V_{LS}$	$V_{LS}$	-0.3 to +13.0	V	
Input voltage	$V_I$	$V_{H0}\text{-}V_{L0}$	-0.3 to $V_{LS} + 0.3$	V	
	$V_I$	SPIO, SPOI, CKP, CKN, LS, REV, LBR, POL, XoP-X2N, YoP-Y2N, ZoP-Z2N	-0.3 to $V_{CC} + 0.3$	V	
Output voltage	$V_O$	SPIO, SPOI	-0.3 to $V_{CC} + 0.3$	V	
	$V_O$	XO1-ZO128	-0.3 to $V_{LS} + 0.3$	V	
Storage temperature	$T_{STG}$		-45 to +125	°C	

### NOTES :

1.  $T_A = +25\text{ }^\circ\text{C}$
2. The maximum applicable voltage on any pin with respect to GND (0 V).

## RECOMMENDED OPERATING CONDITIONS

PARAMETER	SYMBOL	MIN.	TYP.	MAX.	UNIT	NOTE
Supply voltage	$V_{CC}$	+3.0		+3.6	V	1
	$V_{LS}$	+8.0		+12.0	V	
Reference voltage input	$V_{H0}\text{-}V_{H64}$	$0.5V_{LS}$		$V_{LS} - 0.1$	V	
	$V_{L0}\text{-}V_{L64}$	+0.1		$0.5V_{LS}$	V	
Clock frequency	f <sub>CK</sub>			68	MHz	
LCD drive output load capacity	C <sub>L</sub>			150	pF	
Operating temperature	T <sub>OPR</sub>	-20		+75	°C	

### NOTE :

1. The applicable voltage on any pin with respect to GND (0 V).

## ELECTRICAL CHARACTERISTICS

## DC Characteristics

(V<sub>CC</sub> = +3.0 to +3.6 V, V<sub>LS</sub> = +8.0 to +12.0 V, T<sub>OPR</sub> = -20 to +75 °C)

PARAMETER	SYMBOL	CONDITIONS	APPLICABLE PINS	MIN.	TYP.	MAX.	UNIT	NOTE
Input "Low" voltage	V <sub>IL</sub>		SPIO, SPOI, LS, LBR, REV, POL	GND		0.3V <sub>CC</sub>	V	
Input "High" voltage	V <sub>IH</sub>			0.7V <sub>CC</sub>		V <sub>CC</sub>	V	
RSDS Input "Low" voltage	V <sub>ILRSDS</sub>		X <sub>0P</sub> -X <sub>2N</sub> , Y <sub>0P</sub> -Y <sub>2N</sub> , Z <sub>0P</sub> -Z <sub>2N</sub> , CKP, CKN		-200		mV	1
RSDS Input "High" voltage	V <sub>IHRSDS</sub>				200		mV	
RSDS reference voltage	V <sub>COMRSDS</sub>			GND + 0.1	1.2	V <sub>CC</sub> - 1.2	V	2
Output "Low" voltage	V <sub>OL</sub>	I <sub>OL</sub> = 0.3 mA	SPIO, SPOI	GND		GND + 0.4	V	
Output "High" voltage	V <sub>OH</sub>	I <sub>OH</sub> = -0.3 mA		V <sub>CC</sub> - 0.4		V <sub>CC</sub>	V	
Input "Low" current	I <sub>ILL1</sub>		X <sub>0P</sub> -X <sub>2N</sub> , Y <sub>0P</sub> -Y <sub>2N</sub> , Z <sub>0P</sub> -Z <sub>2N</sub> , SPIO, SPOI, CKP, CKN, LS LBR, REV, POL			10	μA	
Input "High" current	I <sub>I LH1</sub>		X <sub>0P</sub> -X <sub>2N</sub> , Y <sub>0P</sub> -Y <sub>2N</sub> , Z <sub>0P</sub> -Z <sub>2N</sub> , SPIO, SPOI, CKP, CKN, LS, LBR			10	μA	
	I <sub>I LH2</sub>		POL			400	μA	
Supply current (In operation mode)	I <sub>CC1</sub>	f <sub>CK</sub> = 65 MHz f <sub>LS</sub> = 50 kHz f <sub>REV</sub> = 50 kHz (Data sampling state)	V <sub>CC</sub> -GND			14	mA	
Supply current (In standby mode)	I <sub>CC2</sub>	f <sub>CK</sub> = 65 MHz f <sub>LS</sub> = 50 kHz SPI = REV = GND is fixed. (Standby state)				2	mA	
Supply current (In operation mode)	I <sub>LS1</sub>	f <sub>CK</sub> = 65 MHz f <sub>LS</sub> = 50 kHz f <sub>REV</sub> = 50 kHz (Data sampling state)	V <sub>LS</sub> -GND			5	mA	
Supply current (In standby mode)	I <sub>LS2</sub>	f <sub>CK</sub> = 65 MHz f <sub>LS</sub> = 50 kHz SPI = REV = GND is fixed. (Standby state)				4	mA	
Output voltage range	V <sub>OUT</sub>		X <sub>O1</sub> -Z <sub>O128</sub>	GND + 0.2		V <sub>LS</sub> - 0.2	V	3
Deviations between output voltage pins	V <sub>OD</sub>			-20		+20	mV	
Output current	I <sub>O1</sub> -I <sub>O4</sub>			100	200		μA	4
Resistance between reference voltage input pins	R <sub>GMAH</sub>		V <sub>H0</sub> -V <sub>H64</sub>	10	20	30	kΩ	
	R <sub>GMAL</sub>		V <sub>L0</sub> -V <sub>L64</sub>	10	20	30	kΩ	

**NOTES :**

1.  $V_{COMRSDS} = (V_{**P} + V_{**N})/2 = 1.2 \text{ V}$   
 $**P = X_0P-X_2P, Y_0P-Y_2P, Z_0P-Z_2P$   
 $**N = X_0N-X_2N, Y_0N-Y_2N, Z_0N-Z_2N$
2.  $V_{DIFFRSDS} = V_{**P} - V_{**N} = 0.2 \text{ V}$
3. Criterion of evaluating voltage deviations.
  - (a) Between output voltage pins  
 Measuring values : Output voltage value at the time after  
 10  $\mu\text{s}$  at the rising edge of LS.  
 (Average of several times)  
 (Conditions) Output load capacity is 150 pF.  
 In a state when the reference voltage is fixed.  
 Expecting values : Calculated following these specifications.  
 (Conditions) In a state when the reference voltage is fixed.
  - (b) Between LCD drivers.  
 Measuring values : Applicable to (a).  
 (Conditions) Applicable to (a).  
 Expecting values : Applicable to (a).  
 (Conditions) Applicable to (a).  
 Each input voltage between the LCD drivers must be  
 made perfectly equal by connecting corresponding  
 reference voltage input pins.
4. lo1 : Applied voltage = 8.0 V for output pins XO<sub>1</sub> to ZO<sub>128</sub>.  
 Output voltage = 7.5 V for output pins XO<sub>1</sub> to ZO<sub>128</sub>.  
 V<sub>LS</sub> = 10.0 V  
 lo2 : Applied voltage = 7.0 V for output pins XO<sub>1</sub> to ZO<sub>128</sub>.  
 Output voltage = 7.5 V for output pins XO<sub>1</sub> to ZO<sub>128</sub>.  
 V<sub>LS</sub> = 10.0 V  
 lo3 : Applied voltage = 3.0 V for output pins XO<sub>1</sub> to ZO<sub>128</sub>.  
 Output voltage = 2.5 V for output pins XO<sub>1</sub> to ZO<sub>128</sub>.  
 V<sub>LS</sub> = 10.0 V  
 lo4 : Applied voltage = 2.0 V for output pins XO<sub>1</sub> to ZO<sub>128</sub>.  
 Output voltage = 2.5 V for output pins XO<sub>1</sub> to ZO<sub>128</sub>.  
 V<sub>LS</sub> = 10.0 V

**AC Characteristics** (V<sub>CC</sub> = +3.0 to +3.6 V, V<sub>LS</sub> = +8.0 to +12.0 V, T<sub>OPR</sub> = -20 to +75 °C)

PARAMETER	SYMBOL	CONDITIONS	APPLICABLE PINS	MIN.	TYP.	MAX.	UNIT
Clock frequency	f <sub>CK</sub>		CKP			68	MHz
"H" level pulse width	t <sub>CWH</sub>			6			ns
"L" level pulse width	t <sub>CWL</sub>			6			ns
Input rise time	t <sub>CR</sub>					5	ns
Input fall time	t <sub>CF</sub>					5	ns
Data setup time	t <sub>SUD</sub>		X <sub>0P</sub> -X <sub>2N</sub> , Y <sub>0P</sub> -Y <sub>2N</sub> , Z <sub>0P</sub> -Z <sub>2N</sub>	3			ns
Data hold time	t <sub>HD</sub>			0			ns
Start pulse setup time	t <sub>SUSP</sub>		SPIO, SPOI	1			ns
Start pulse hold time	t <sub>HSP</sub>			2			ns
Start pulse width	t <sub>WSP</sub>					$\frac{1}{f_{CK}}$	ns
Start pulse output delay time	t <sub>DSP</sub>	C <sub>L</sub> = 15 pF					13
LCD drive output delay time 1	t <sub>DO1</sub>	C <sub>L</sub> = 150 pF	XO1-ZO <sub>128</sub>			3	μs
LCD drive output delay time 2	t <sub>DO2</sub>	C <sub>L</sub> = 150 pF					10
LS signal-SPI signal setup time	t <sub>LSSP</sub>		LS	$\frac{1}{f_{CK}}$			ns
LS signal-CK signal hold time	t <sub>HLS</sub>			7			ns
LS signal "H" level width	t <sub>WLS</sub>			$\frac{1}{f_{CK}}$			ns
REV signal-LS signal setup time	t <sub>SURV</sub>		REV	14			ns
REV signal-LS signal hold time	t <sub>HRV</sub>			10			ns

Timing Chart

