



# LIC01-SERIES

Application Specific Discretes  
A.S.D.™

## LIGHT IGNITION CIRCUIT

### FEATURES

- HIGH VOLTAGE BREAKOVER DIODE:  
V<sub>BO</sub> MIN = 195 or 215 V
- HIGH HOLDING CURRENT STRUCTURE:  
I<sub>H</sub> > 50 mA
- HIGH PEAK CURRENT PULSE CAPABILITY:  
I<sub>TRM</sub> = 50 A
- DIRECT OPERATION ON 220/240 VAC MAINS CIRCUITS.

### BENEFITS

- SPACE SAVING THANKS TO MONOLITHIC FUNCTION INTEGRATION
- HIGH RELIABILITY WITH PLANAR TECHNOLOGY

### DESCRIPTION

The LIC01 has been especially designed for high voltage pulse generation circuits such as light ignitors for :

- . High pressure sodium lamp
- . Lamp flashing circuit
- . Metal Halid lamp

It uses a high performance planar diffused technology device suitable for high surge current operation in rugged environmental conditions.

When the voltage across the device reaches the breakover voltage, it decreases from an off state to low voltage on-state condition. When the current through the circuit drops below the holding current I<sub>H</sub>, the device comes back to the off state.

DEVICE TYPE	BREAKDOWN VOLTAGE RANGE
LIC01-195	V <sub>BO</sub> min: 195V V <sub>BO</sub> max: 230V
LIC01-215	V <sub>BO</sub> min: 215V V <sub>BO</sub> max: 255V

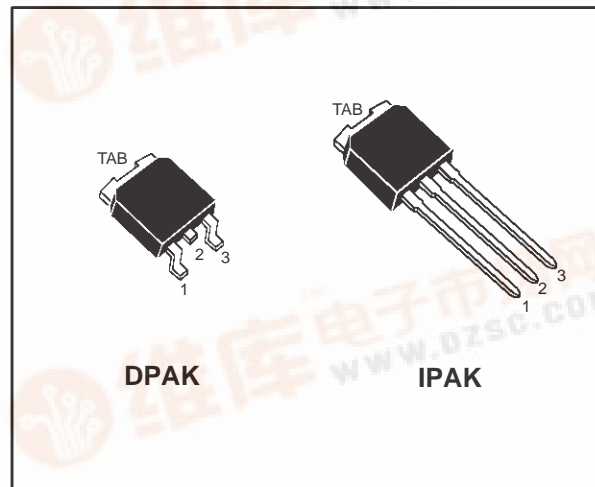

### FUNCTIONAL DIAGRAM

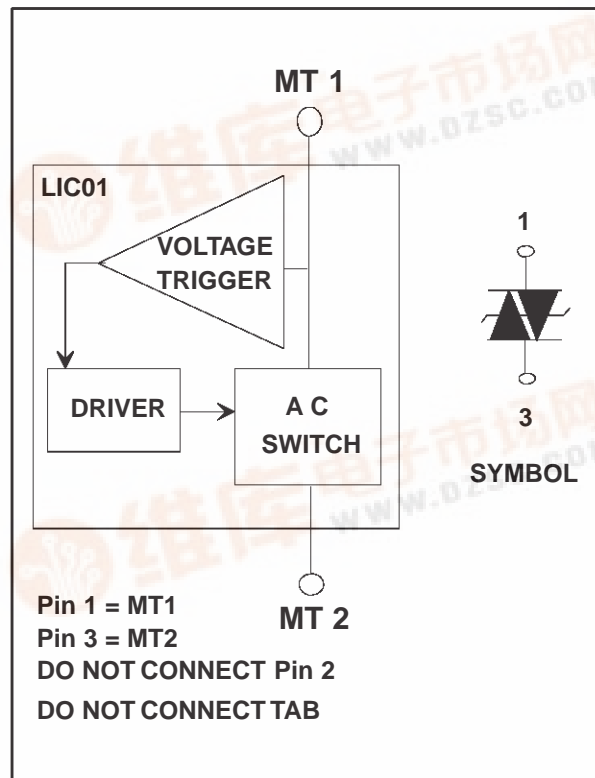

## LIC01-SERIES

### ABSOLUTE RATINGS (limiting values)

Symbol	Parameter		Value	Unit
$I_{TRM}$	Repetitive surge peak on state current	$t_p = 10\mu s$ ( note 1)	$\pm 50$	A
$I_{T(RMS)}$	RMS on state current	$T_{amb} = 90^\circ C$	1.2	A
$di/dt$	Critical rate of rise on state current		80	A/ $\mu s$
$V_{DRM} / V_{RRM}$	Repetitive peak off state voltage	$T_j = 125^\circ C$	180	V
$T_{stg}$	Storage junction temperature range		- 40 to + 125	$^\circ C$
$T_j$	Operating junction temperature range		-20 to 125	$^\circ C$
$T_L$	Maximum lead temperature for soldering during 10s		260	$^\circ C$

Note 1 : Test current waveform

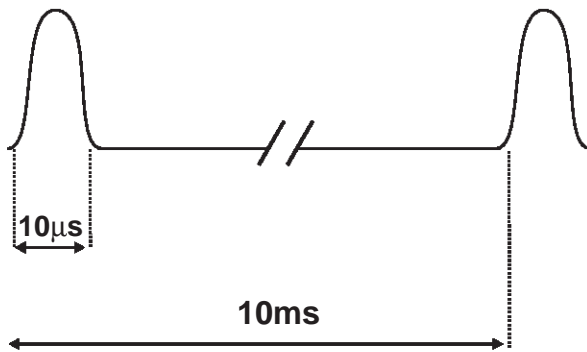

### THERMAL RESISTANCE

Symbol	Parameter	Value	Unit
$R_{th(j-a)}$	Junction to ambient	100	$^\circ C/W$
$R_{th(j-c)}$	Junction to case	3.5	$^\circ C/W$

### ORDERING INFORMATION

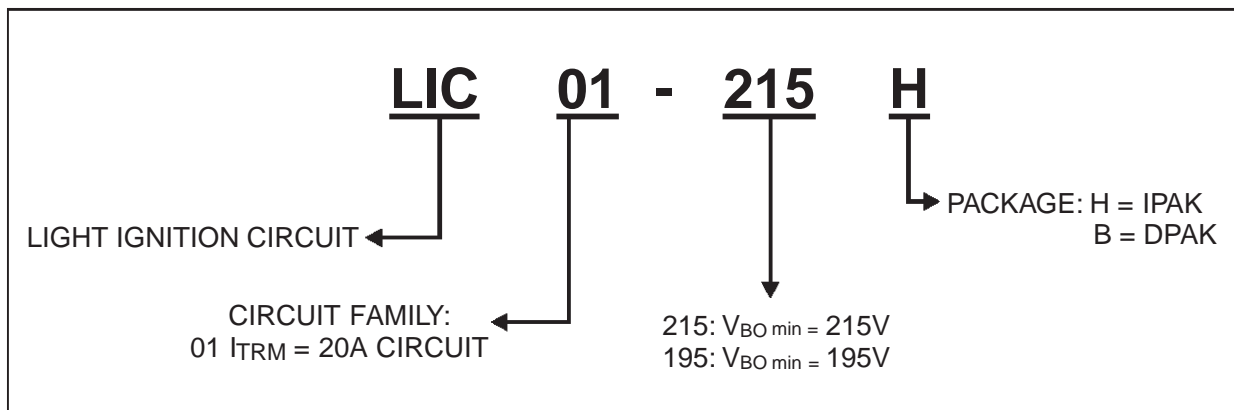

**ELECTRICAL CHARACTERISTICS**

Symbol	Parameters
$V_{RM}$	Stand-off voltage
$V_{TM}$	On-state voltage
$V_{BO}$	Breakover voltage
$I_{TM}$	On-state current
$I_H$	Holding current
$I_{BO}$	Breakover current
$I_{RM}$	Leakage current

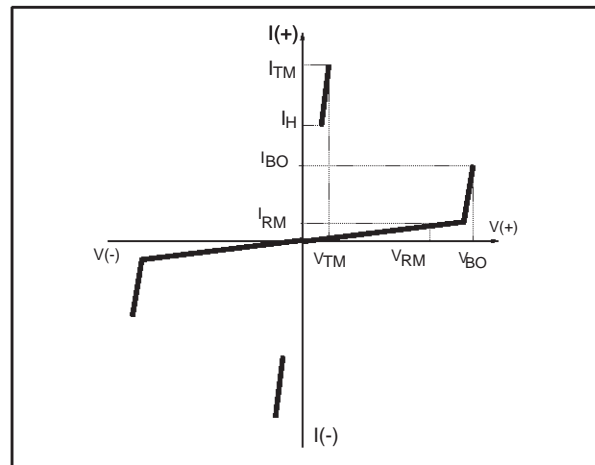

**ELECTRICAL PARAMETERS**

Symbol	Test conditions		Value	Unit	
$I_{RM}$	$V_D = V_{RM} 180V$		$T_j = 25^{\circ}C$ MAX	5	$\mu A$
			$T_j = 125^{\circ}C$ MAX	50	$\mu A$
$V_{BO}$	$I_{BO}$	LIC01-195	$T_j = 25^{\circ}C$ MIN	195	V
			MAX	230	
	LIC01-215	$T_j = 25^{\circ}C$ MIN	215	V	
		MAX	255		
$I_{BO}$	$V_{BO} \text{ max.}$		$T_j = 25^{\circ}C$ TYP	200	$\mu A$
			MAX	500	
$I_H$	$I_T = 350mA$	$T_j = 25^{\circ}C$	MIN	50	mA
$V_{TM}$	$I_{TM} = 1A$	$T_j = 25^{\circ}C$	MAX	5	V

**HOLDING CURRENT TEST CIRCUIT**

$R1 = 1k\Omega / 50W$  ( a 220V / 60W bulb can be used )

$R2 = 22\Omega$   
 $C2 = 220nF$  } Auxiliary network providing the complete firing of the LIC01 under test

$I_T$  0.1A/div

$t = 2ms/div$

$I_H+$

$I_H-$

## LIC01-SERIES

### VARIATION OF $V_{BO}$ VERSUS JUNCTION TEMPERATURE

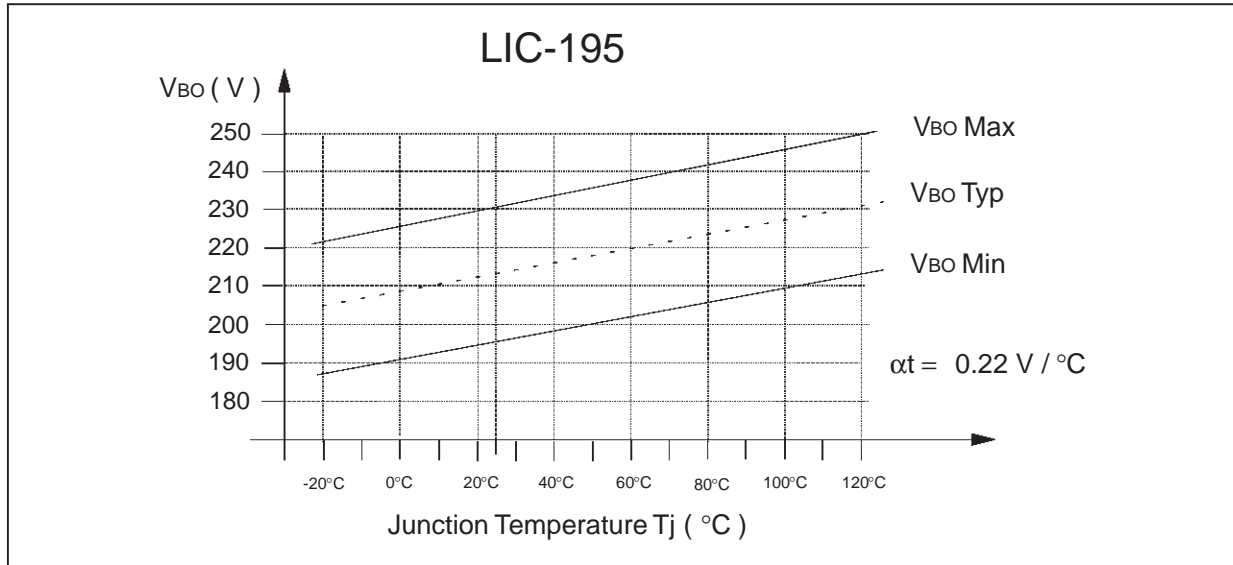

### VARIATION OF $V_{BO}$ VERSUS JUNCTION TEMPERATURE

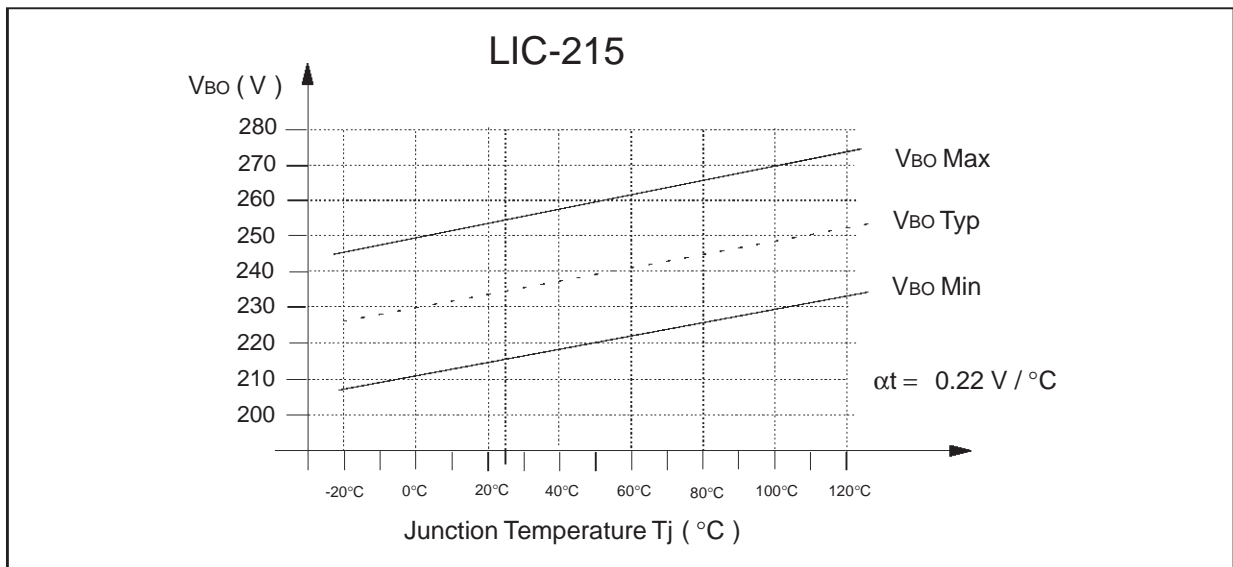

### TYPICAL APPLICATION

When the peak voltage across C1 reaches the break over voltage  $V_{BO}$  of the LIC01, this device turns on and produces a pulse of current through the primary of the transformer. In turns, the transformer generates high voltage pulses across the lamp.

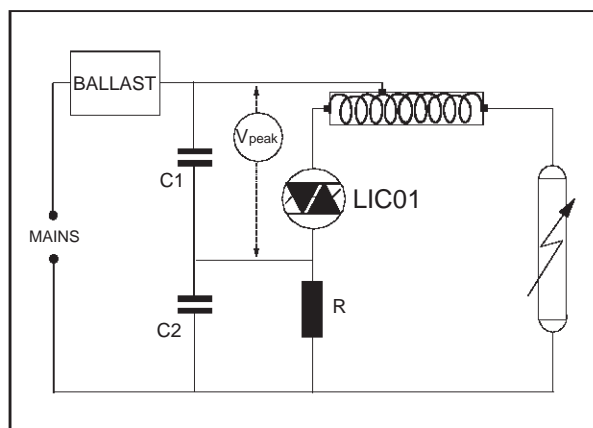

**PACKAGE MECHANICAL DATA**  
DPAK (Plastic)

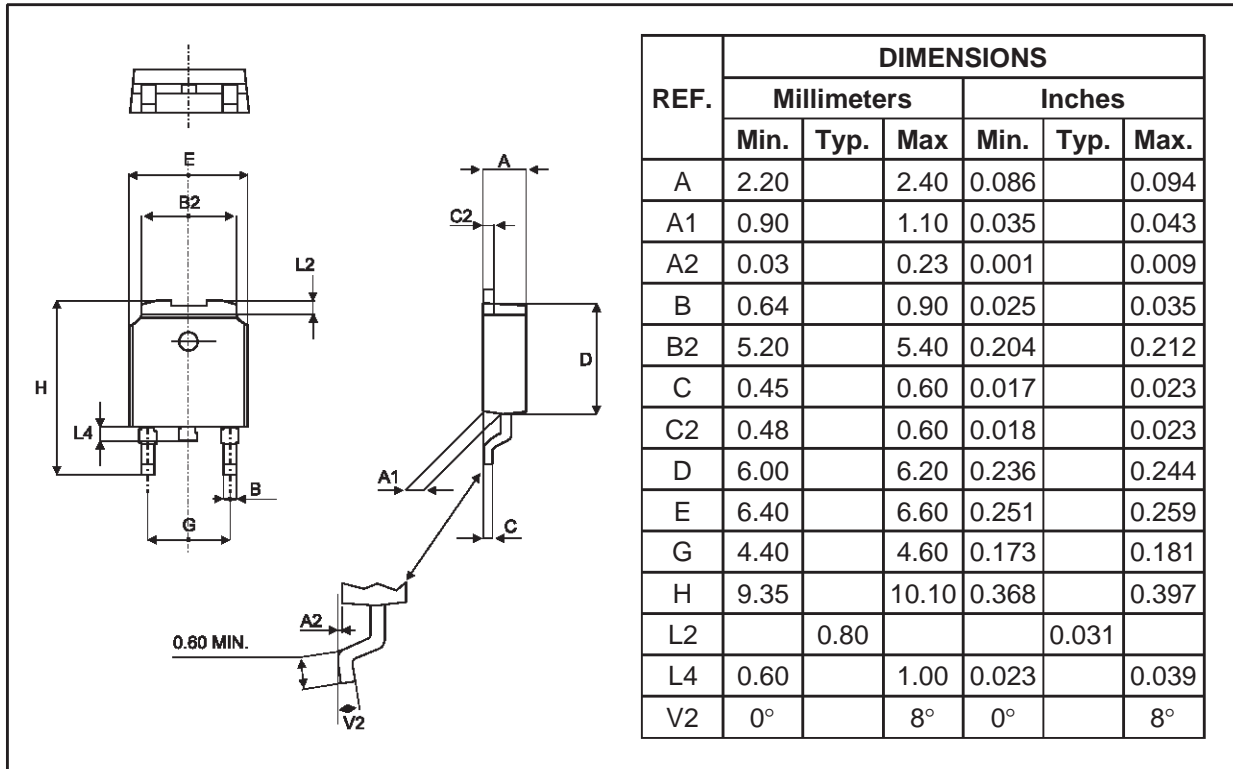

**FOOT PRINT DIMENSIONS (in millimeters)**

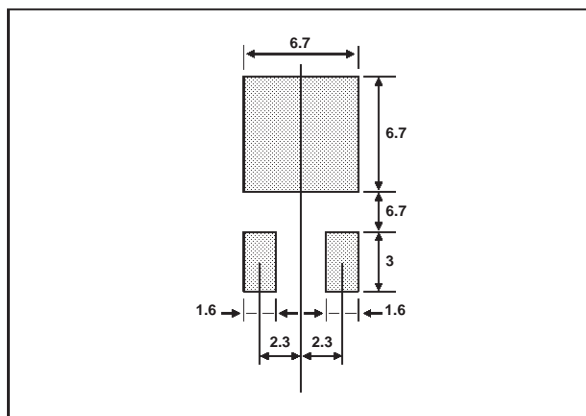

## LIC01-SERIES

### PACKAGE MECHANICAL DATA IPAK (Plastic)

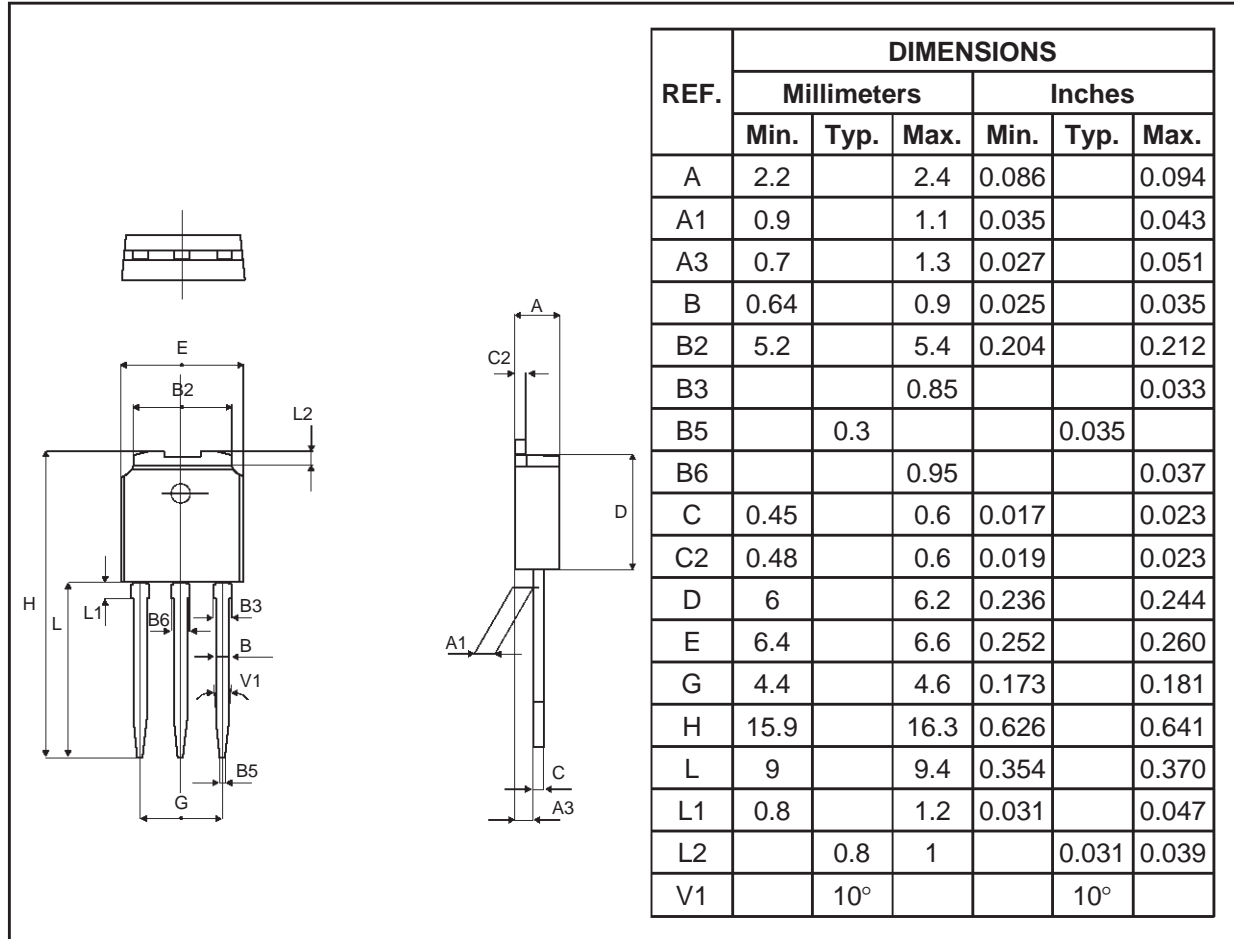

Type	Marking	Package	Weight	Base qty	Delivery mode
LIC01-xxxH	LIC01-xxxH	IPAK	0.350g	75	Tube
LIC01-xxxB	LIC01-xxxB	DPAK	0.300g	75	Tube

Information furnished is believed to be accurate and reliable. However, STMicroelectronics assumes no responsibility for the consequences of use of such information nor for any infringement of patents or other rights of third parties which may result from its use. No license is granted by implication or otherwise under any patent or patent rights of STMicroelectronics. Specifications mentioned in this publication are subject to change without notice. This publication supersedes and replaces all information previously supplied. STMicroelectronics products are not authorized for use as critical components in life support devices or systems without express written approval of STMicroelectronics.

The ST logo is a registered trademark of STMicroelectronics

© 2000 STMicroelectronics - Printed in Italy - All rights reserved.

STMicroelectronics GROUP OF COMPANIES

Australia - Brazil - China - Finland - France - Germany - Hong Kong - India - Italy - Japan - Malaysia  
Malta - Morocco - Singapore - Spain - Sweden - Switzerland - United Kingdom - U.S.A.

<http://www.st.com>