



## LS SERIES ENCODER/DECODER DESIGN GUIDE

### DESCRIPTION

The Linx LS Series encoders and decoders provide a simple, but reliable, protocol for the transmission of switch closures or button contacts. This series can find use in any simple, low-cost remote control application. Simply take a data line high on the encoder and a corresponding line will go high on the decoder. No programming or addressing makes integrating the LS extremely easy while maintaining a robust link.

### FEATURES

- No addressing or programming
- Easy to use
- Very low current consumption
- Four data lines
- Easy serial interface
- Selectable baud rates
- High noise immunity
- Standard PDIP package

### APPLICATIONS

- Range Testing
- Simple Remote Control
- Wire Elimination
- Remote Status Monitoring
- Lighting Control

### PACKAGE

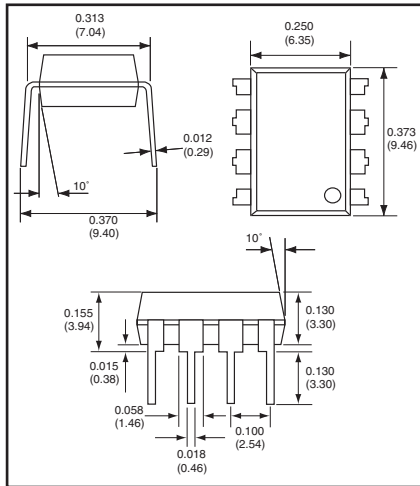

Figure 1: Package Dimensions

### PCB LAYOUT

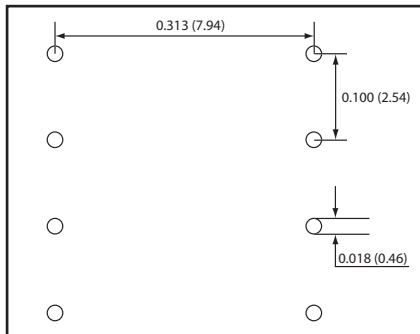

Figure 2: PCB Layout Dimensions

### ORDERING INFORMATION

| PART #          | DESCRIPTION          |
|-----------------|----------------------|
| LICAL-ENC-LS001 | Low Security Encoder |
| LICAL-DEC-LS001 | Low Security Decoder |

## ABSOLUTE MAXIMUM RATINGS

|                                  |      |    |                |     |
|----------------------------------|------|----|----------------|-----|
| Supply Voltage, $V_{CC}$         | -0.3 | to | +6.5           | VDC |
| Max Current Sourced By Data Pins |      |    | 25             | mA  |
| Max Current Sunk By Data Pins    |      |    | 25             | mA  |
| Operating Temperature            | -40  | to | +125           | °C  |
| Storage Temperature              | -65  | to | +150           | °C  |
| Any Input or Output Pin          | -0.3 | to | $V_{CC} + 0.3$ | VDC |
| Max Current Into $V_{CC}$        |      |    | 250            | mA  |
| Max Current Out Of GND           |      |    | 300            | mA  |

**\*NOTE\*** Exceeding any of the limits of this section may lead to permanent damage to the device. Furthermore, extended operation at these maximum ratings may reduce the life of this device.

## ELECTRICAL CHARACTERISTICS

| Parameter       | Designation | Min.          | Typ. | Max.           | Units   | Notes |
|-----------------|-------------|---------------|------|----------------|---------|-------|
| Supply Voltage  | $V_{CC}$    | 2.0           | ---  | 5.5            | VDC     |       |
| Supply Current  | $I_{CC}$    |               |      |                |         |       |
| @ 2.0V $V_{CC}$ |             | ---           | 340  | 450            | $\mu$ A | 1     |
| @ 3.0V $V_{CC}$ |             | ---           | 500  | 700            | $\mu$ A | 1     |
| @ 5.0V $V_{CC}$ |             | ---           | 800  | 1100           | $\mu$ A | 1     |
| Sleep Current   |             |               |      |                |         |       |
| @ 2.0V $V_{CC}$ |             | ---           | 0.99 | 700            | nA      |       |
| @ 3.0V $V_{CC}$ |             | ---           | 1.2  | 770            | nA      |       |
| @ 5.0V $V_{CC}$ |             | ---           | 2.9  | 995            | nA      |       |
| Input Low       | $V_{IL}$    | GND           | ---  | $(0.15)V_{CC}$ | V       | 2     |
| Input High      | $V_{IH}$    | $(0.8)V_{CC}$ | ---  | $V_{CC}$       | V       | 3     |
| Output Low      | $V_{OL}$    | ---           | ---  | 0.6            | V       |       |
| Output High     | $V_{OH}$    | $V_{CC}-0.7$  | ---  | ---            | V       |       |

### Notes:

- Current consumption with no active loads.
- For 3V supply,  $(0.15 \times 3.0) = 0.45V$  max.
- For 3V supply,  $(0.8 \times 3.0) = 2.4V$  min.



### \*CAUTION\*

This product is a static-sensitive component. Always wear an ESD wrist strap and observe proper ESD handling procedures when working with this device. Failure to observe this precaution may result in device damage or failure.

## PIN ASSIGNMENTS

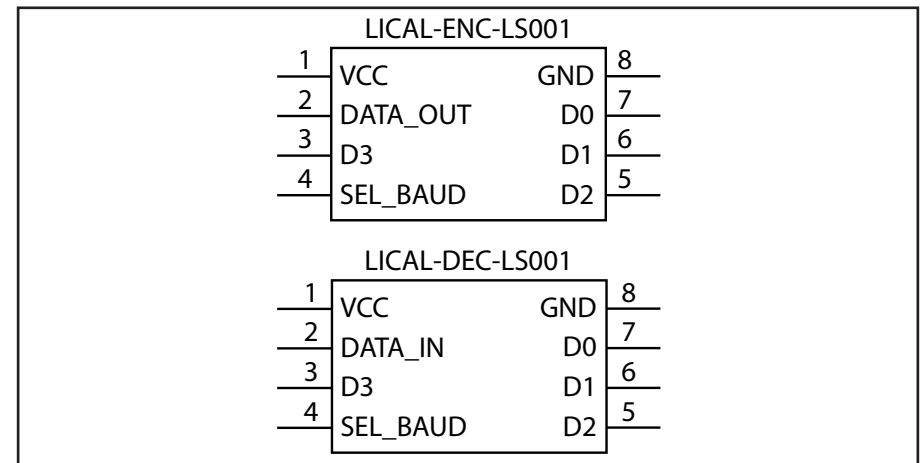

Figure 3: Encoder and Decoder Pin Assignments

## ENCODER PIN ASSIGNMENTS

| Pin Name | Pin Number | I/O | Description             |
|----------|------------|-----|-------------------------|
| VCC      | 1          | —   | Positive Power Supply   |
| DATA_OUT | 2          | O   | Serial Data Output      |
| SEL_BAUD | 4          | I   | Baud Rate Selection Pin |
| GND      | 8          | —   | Ground                  |
| D0 - D3  | 3, 5, 6, 7 | I   | Data Input Pins         |

## DECODER PIN ASSIGNMENTS

| Pin Name | Pin Number | I/O | Description             |
|----------|------------|-----|-------------------------|
| VCC      | 1          | —   | Positive Power Supply   |
| DATA_OUT | 2          | I   | Serial Data Input       |
| SEL_BAUD | 4          | I   | Baud Rate Selection Pin |
| GND      | 8          | —   | Ground                  |
| D0 - D3  | 3, 5, 6, 7 | O   | Data Output Pins        |

## PIN DESCRIPTIONS

---

### VDD

This is the positive power supply.

### DATA\_OUT

The encoder will output a serial data stream on this line.

### DATA\_IN

The decoder will monitor this line for data.

### SEL\_BAUD

This line is used to select the baud rate of the serial data stream. The state of the line allows the selection of one of two possible baud rates as shown in the adjoining chart.

| SEL_BAUD | Baud Rate (bps) |
|----------|-----------------|
| 0        | 2400            |
| 1        | 9600            |

### GND

These lines are connected to ground.

### Data Lines

The LS Series has three data lines, D0 through D3. When any of these lines goes high on the encoder, their states are recorded, encoded for transmission, and then reproduced on the outputs of the decoder.

## PRODUCTION CONSIDERATIONS

---

The LS Series encoders and decoders are implemented in an industry standard 8-Lead Plastic Dual In-Line Package (8-PDIP). The package and layout dimensions are shown on Page 1. These components are leaded through-hole parts and may be hand or wave soldered.

## THEORY OF OPERATION

---

The Linx LS Series encoder and decoder are designed to register button presses or contact closures. When a pin goes high on the encoder, a signal is sent to make a corresponding pin go high on the decoder. The outputs of the decoder can then be used to activate almost anything, from drive a LED or buzzer to activate digital circuitry.

The LS Series does not require any programming or addressing and its simplicity makes it a good choice for basic remote control devices that are designed to turn something on and off.

## ENCODER OPERATION

---

Upon power-up the encoder enters sleep mode. As soon as one of the data lines goes high it will wake up and begin the transmit process.

First, the encoder will record the state of the data lines, encode for error correction and assemble the packet. It will then output the packet on the DATA\_OUT line. The encoder will repeat the transmission process for as long as one of the data lines is high, otherwise it will go back to sleep. It will update the state of the data lines with each packet and it will finish the current transmission even if all of the lines are pulled to ground.

## DECODER OPERATION

---

The LS decoder begins by waiting for the DATA\_IN line to transition from low to high. At that point, the decoder will accept the data, check it for errors and confirm that the bytes are valid. If the data pass all of the checks, then the data bits are output on the decoder's data lines. If any of these checks fail, then the decoder will ignore the received packet and look for the next one.

The decoder has a built-in debounce circuit to guard against signal cutout. This is a timer that maintains the current state of the data lines until changed by a valid packet or until no valid packets are received for 131mS. After 131mS elapses the decoder pulls all of the data lines to ground and goes back to sleep. This helps protect devices attached to the decoder by smoothing out the output response. Rapid switching resulting from lost packets could cause damage to devices, such as relays or motors, that may be controlled by the decoder.

This debounce circuit helps in noisy environments and at the range limit of the transmitter and receiver where lost packets and cutouts are more frequent. The drawback is that there is the 131mS lag time between the end of the transmission and when the data lines are turned off. This is generally not a problem with manual remote control applications, but must be taken into account in applications where timing is critical.

## APPLICATION EXAMPLE

---

The LS series encoders and decoders would typically be used in remote control applications to register button presses to activate circuitry in a remote device. Figure 4 shows an example application circuit.

A SPDT switch is used in both circuits to set the baud rate. This switch will pull the BAUD\_SEL line to either ground or VCC for selection of one of the baud rates described in the Pin Descriptions section of this manual. The baud rate on both sides must match in order for the encoder and decoder to correctly operate.

Two pushbutton switches are connected to the data lines on the encoder. Since none of the data lines have internal pull resistors, external resistors are used to pull the data lines to ground when not in use. Without these resistors, the state of the data lines could not be guaranteed and performance may not be predictable. In this example, only two data lines are used so the other two are tied directly to ground. With this circuit, pressing either of the buttons will cause the data line to go high and initiate a transmission.

On the decoder side, a piezoelectric buzzer is attached directly to the D1 line. When the button connected to the D1 line on the encoder is pressed, the buzzer will sound. The D0 line is connected to a relay through a transistor buffer. The decoder can output 25mA, which is sufficient to drive small relays, but may not work for larger coils. The transistor is used to provide the higher current and voltage required to activate a larger relay. With this circuit, when the D0 line goes high it will turn on the transistor, which will energize the relay and connect the terminals.

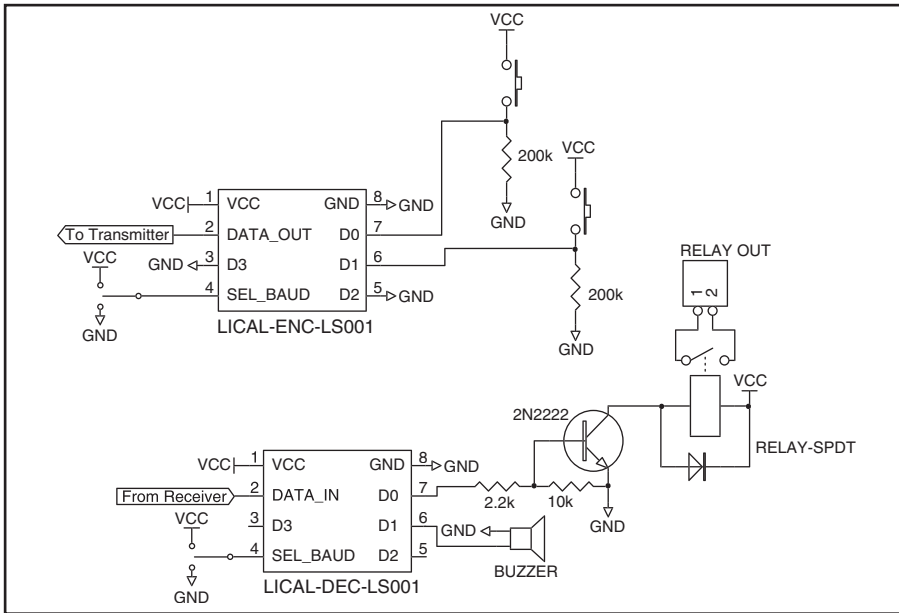

Figure 4: Application Circuits

## ON-LINE RESOURCES



[www.linxtechnologies.com](http://www.linxtechnologies.com)

- Latest News
- Data Guides
- Application Notes
- Knowledge Base
- Software Updates



If you have questions regarding any Linx product and have Internet access, make [www.linxtechnologies.com](http://www.linxtechnologies.com) your first stop. Our website is organized in an intuitive format to give you the answers you need in record time. Day or night, the Linx website gives you instant access to the latest information regarding the products and services of Linx. It's all here: manual and software updates, application notes, a comprehensive knowledge base, FCC information and much more. Be sure to visit often!

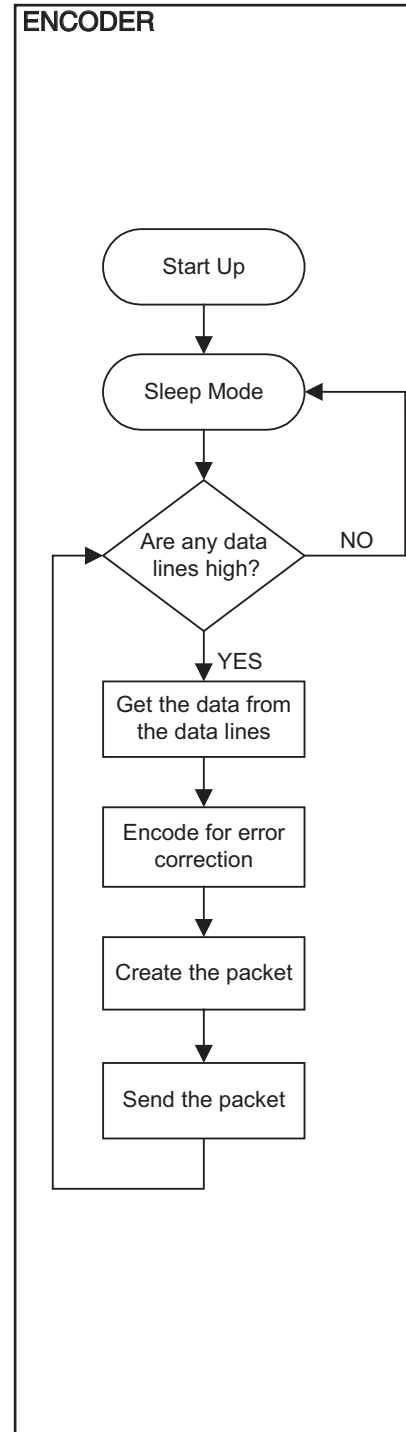

Figure 5: Encoder Flowchart

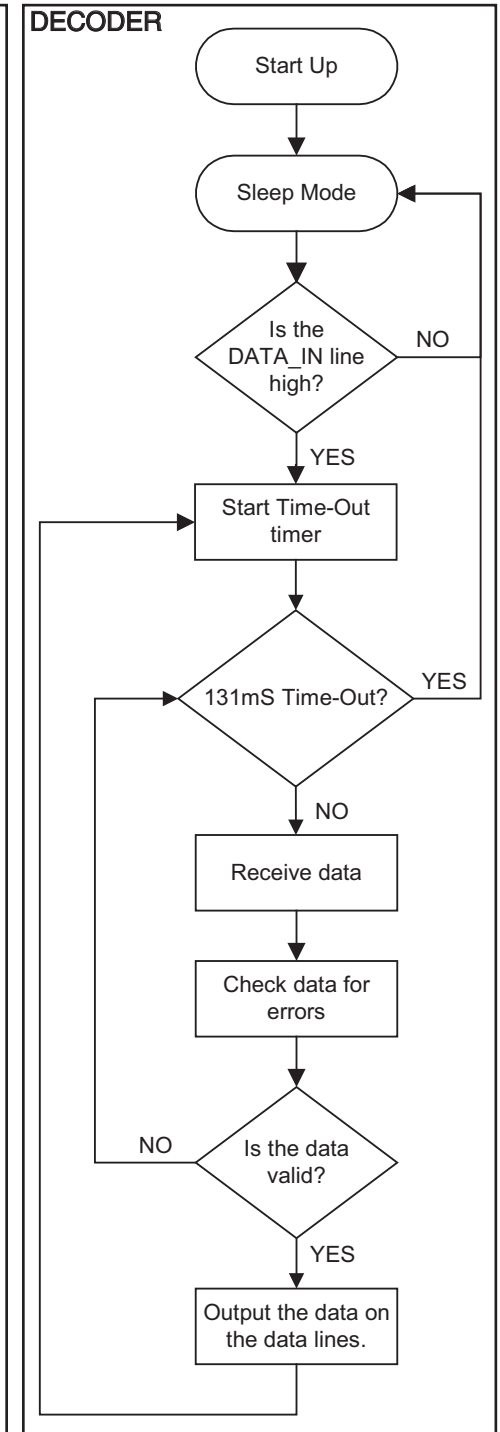

Figure 6: Decoder Flowchart



## U.S. CORPORATE HEADQUARTERS:

### ***LINX TECHNOLOGIES, INC.***

**575 S.E. ASHLEY PLACE  
GRANTS PASS, OR 97526**

**PHONE: (541) 471-6256**

**FAX: (541) 471-6251**

**<http://www.linstechnologies.com>**

## **Disclaimer**

---

LinX Technologies is continually striving to improve the quality and function of its products; for this reason, we reserve the right to make changes without notice. The information contained in this Data Sheet is believed to be accurate as of the time of publication. Specifications are based on representative lot samples. Values may vary from lot to lot and are not guaranteed. LinX Technologies makes no guarantee, warranty, or representation regarding the suitability or legality of any product for use in a specific application. None of these devices is intended for use in applications of a critical nature where the safety of life or property is at risk. The user assumes full liability for the use of product in such applications. Under no conditions will LinX Technologies be responsible for losses arising from the use or failure of the device in any application, other than the repair, replacement, or refund limited to the original product purchase price. Some devices described in this publication are patented. Under no circumstances shall any user be conveyed any license or right to the use or ownership of these patents.

---