

FEATURES

- *Guaranteed* 200pA max. input offset current
- *Guaranteed* 2nA max. input bias current
- *Guaranteed* 600 μ A max. supply current
- *Guaranteed* 0.5mV max. offset voltage
- *Guaranteed* 5 μ V/ $^{\circ}$ C max. drift
- Wide supply voltage range: \pm 2V to \pm 18V

APPLICATIONS

- Integrators
- Transducer amplifiers
- Analog memories
- Light meters

DESCRIPTION

The LM108 series of precision operational amplifiers are particularly well-suited for high source impedance applications requiring low offset and bias currents as well as low power dissipation. Unlike FET input amplifiers, the offset and bias currents of the LM108 do not change significantly with temperature variations. Advanced design, processing and testing techniques make Linear's LM108 a superior choice over previous devices.

A photodiode sensor application is shown below. For applications requiring higher performance, see the LT1008, and LT1012.

2

Amplifier For Photodiode Sensor

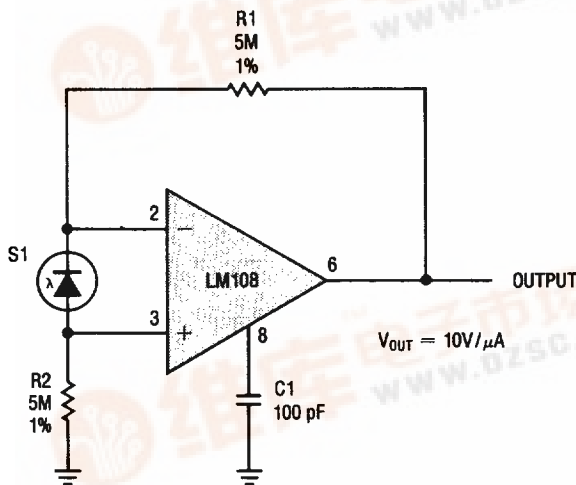

Input Currents

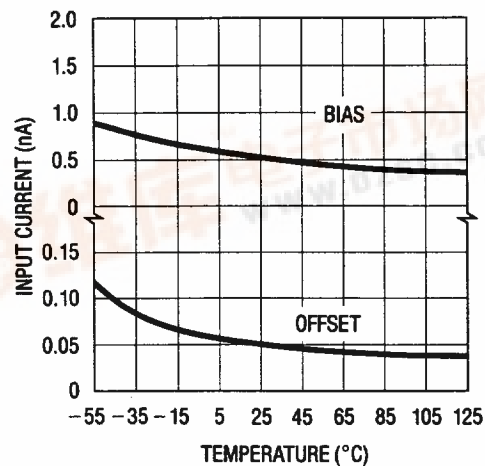

LM108A/LM308A LM108/LM308

ABSOLUTE MAXIMUM RATINGS

Supply Voltage	
LM108A/LM108	± 20V
LM308A/LM308	± 18V
Differential Input Current (Note 1)	± 10mA
Input Voltage (Note 2)	± 15V
Output Short Circuit Duration	Indefinite
Operating Temperature Range	
LM108A/LM108	-55°C to 125°C
LM308A/LM308	0°C to 70°C
Storage Temperature Range	
All Devices	-65°C to 150°C
Lead Temperature (Soldering, 10 sec.)	300°C

PACKAGE/ORDER INFORMATION

<p>TOP VIEW</p> <p>METAL CAN H PACKAGE</p>	<p>ORDER PART NO.</p> <p>LM108AH LM108H LM308AH LM308H</p>
<p>TOP VIEW</p> <p>PLASTIC DIP N8 PACKAGE</p>	<p>LM308AN8 LM308N8</p>

ELECTRICAL CHARACTERISTICS $\pm 5V \leq V_s \leq \pm 20V$ and $-55^\circ C \leq T_A \leq 125^\circ C$, unless otherwise noted.

SYMBOL	PARAMETER	CONDITIONS	LM108A			LM108			UNITS
			MIN	TYP	MAX	MIN	TYP	MAX	
V_{OS}	Input Offset Voltage	$T_A = 25^\circ C$	●	0.3	0.5	0.7	2.0	mV	
					1.0		3.0	mV	
$\frac{\Delta V_{OS}}{\Delta Temp}$	Average Temperature Coefficient of Input Offset Voltage		●	1.0	5.0	3.0	15	$\mu V/^\circ C$	
I_{OS}	Input Offset Current	$T_A = 25^\circ C$	●	0.05	0.2	0.05	0.2	nA	
			●		0.4		0.4	nA	
$\frac{\Delta I_{OS}}{\Delta Temp}$	Average Temperature Coefficient of Input Offset Current		●	0.5	2.5	0.5	2.5	$\mu A/^\circ C$	
I_B	Input Bias Current	$T_A = 25^\circ C$	●	0.5	2.0	0.5	2.0	nA	
			●		3.0		3.0	nA	
A_{VOL}	Large Signal Voltage Gain	$T_A = 25^\circ C, V_S \pm 15V, V_{OUT} = \pm 10V, R_L \geq 10k\Omega$	●	80	300	50	300	V/mV	
			●	40		25		V/mV	
CMRR	Common Mode Rejection Ratio		●	96	110	85	100	dB	
PSRR	Power Supply Rejection Ratio		●	96	110	80	96	dB	
	Input Voltage Range	$V_S = \pm 15V$	●	± 13.5		± 13.5		V	
V_{OUT}	Output Voltage Swing	$V_S = \pm 15V, R_L = 10k\Omega$	●	± 13	± 14	± 13	± 14	V	
R_{IN}	Input Resistance	$T_A = 25^\circ C$ (Note 3)		30	70	30	70	M Ω	
I_S	Supply Current	$T_A = 25^\circ C$		0.3	0.6	0.3	0.6	mA	
		$T_A = 125^\circ C$		0.15	0.4	0.15	0.4	mA	

ELECTRICAL CHARACTERISTICS $\pm 5V \leq V_s \leq \pm 15V$ and $0^\circ C \leq T_A \leq 70^\circ C$, unless otherwise noted.

SYMBOL	PARAMETER	CONDITIONS	LM308A			LM308			UNITS
			MIN	TYP	MAX	MIN	TYP	MAX	
V_{OS}	Input Offset Voltage	$T_A = 25^\circ C$	●	0.3	0.5 0.73	2.0	7.5 10	mV mV	
$\frac{\Delta V_{OS}}{\Delta Temp}$	Average Temperature Coefficient of Input Offset Voltage		●	2.0	5.0	6.0	30	$\mu V/^\circ C$	
I_{OS}	Input Offset Current	$T_A = 25^\circ C$	●	0.2	1.0 1.5	0.2	1.0 1.5	nA nA	
$\frac{\Delta I_{OS}}{\Delta Temp}$	Average Temperature Coefficient of Input Offset Current		●	2.0	10	2.0	10	$\mu A/^\circ C$	
I_B	Input Bias Current	$T_A = 25^\circ C$	●	1.5	7.0 10	1.5	7.0 10	nA nA	
A_{VOL}	Large Signal Voltage Gain	$T_A = 25^\circ C, V_S = \pm 15V, V_{OUT} = \pm 10V, R_L \geq 10k\Omega$	●	80 60	300	25 15	300	V/mV V/mV	
CMRR	Common Mode Rejection Ratio		●	96	110	80	100	dB	
PSRR	Power Supply Rejection Ratio		●	96	110	80	96	dB	
	Input Voltage Range	$V_S = \pm 15V$	●	± 14		± 14		V	
V_{OUT}	Output Voltage Swing	$V_S = \pm 15V, R_L = 10k\Omega$	●	± 13	± 14	± 13	± 14	V	
R_{IN}	Input Resistance	$T_A = 25^\circ C$ (Note 3)		10	40	10	40	M Ω	
I_S	Supply Current	$T_A = 25^\circ C$		0.3	0.8	0.3	0.8	mA	

The ● denotes the specifications which apply over the full operating temperature range.

For MIL-STD components, please refer to LTC 883 data sheet for test listing and parameters.

Note 1: Differential input voltages greater than 1V will cause excessive current to flow through the input protection diodes unless current limiting resistance is used.

Note 2: For supply voltages less than $\pm 15V$, the maximum input voltage is equal to the supply voltage.

Note 3: Guaranteed by design.

TYPICAL APPLICATIONS

COMPENSATION CIRCUITS

Standard Compensation Circuit

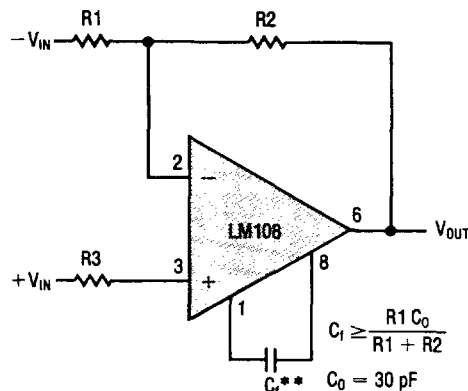

** BANDWIDTH AND SLEW RATE ARE PROPORTIONAL TO $1/C_1$

Alternate* Frequency Compensation

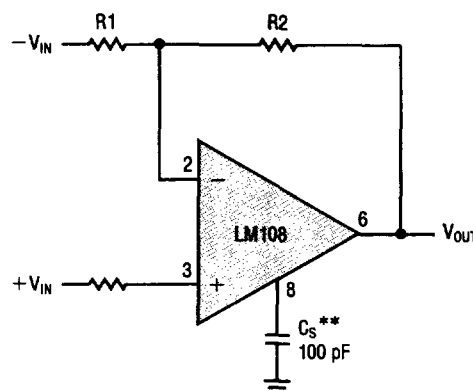

* IMPROVES REJECTION OF POWER SUPPLY NOISE BY A FACTOR OF TEN.

** BANDWIDTH AND SLEW RATE ARE PROPORTIONAL TO $1/C_s$

Feedforward Compensation

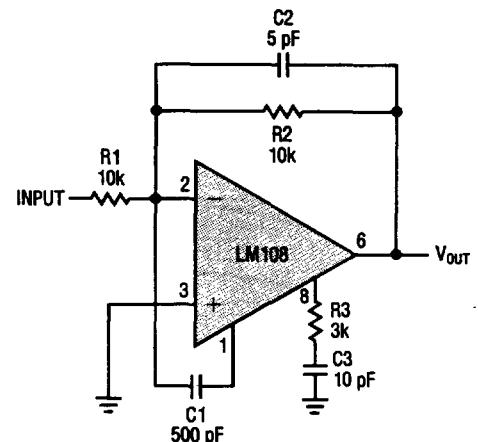

LM108A/LM308A LM108/LM308

TYPICAL PERFORMANCE CHARACTERISTICS

Guaranteed Offset Error

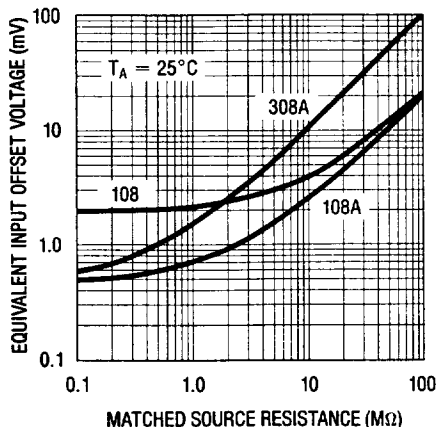

Guaranteed Drift Error

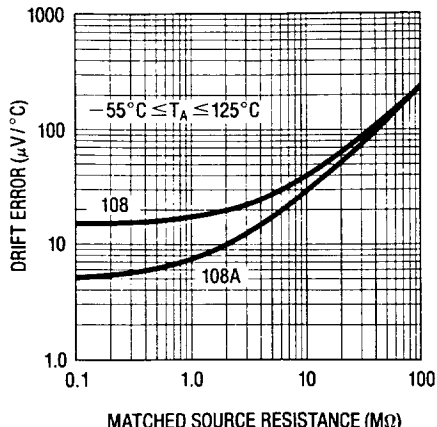

Input Noise Voltage

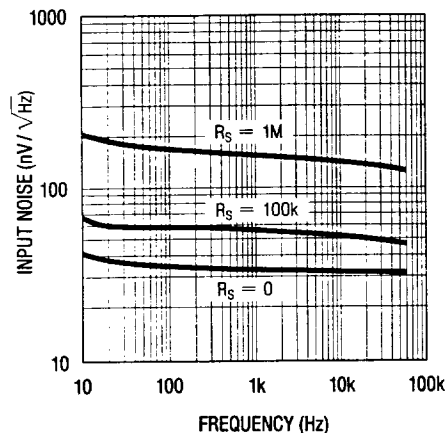

Open Loop Frequency Response

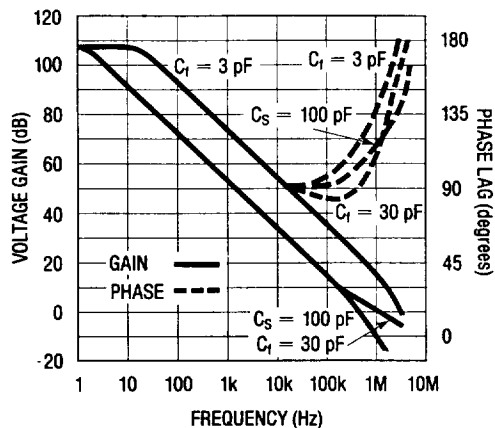

Large Signal Frequency Response

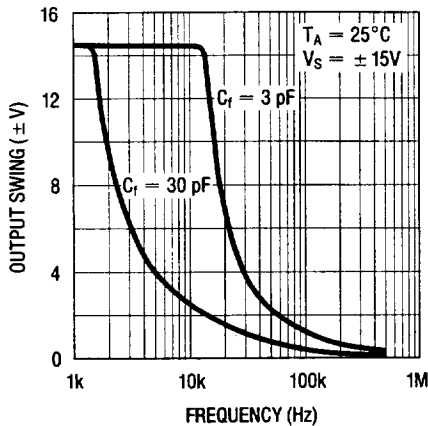

Voltage Follower Pulse Response

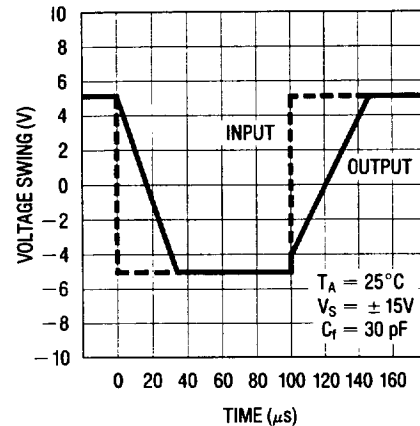

Voltage Gain

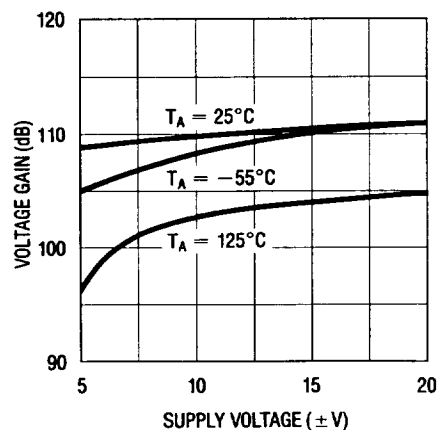

Output Swing

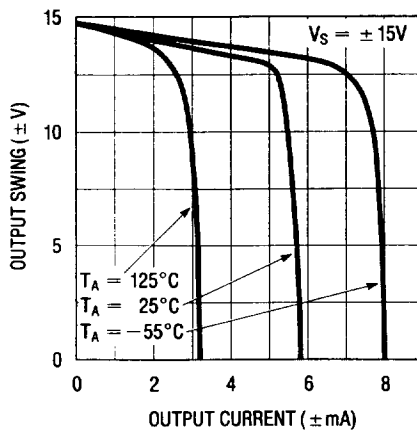

Supply Current

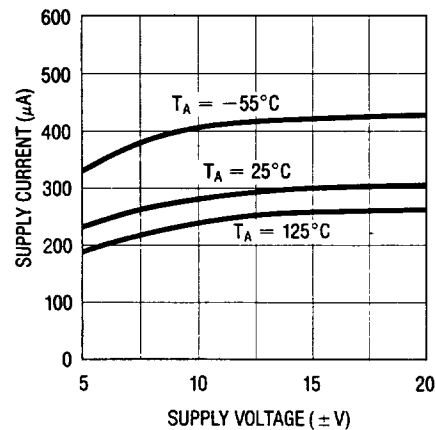

TYPICAL PERFORMANCE CHARACTERISTICS

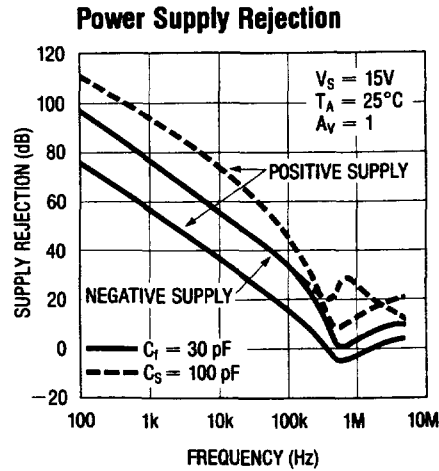
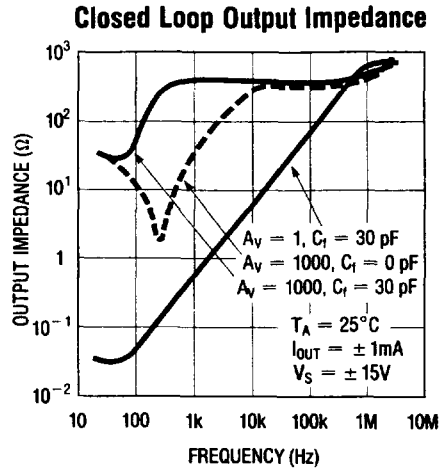

TYPICAL APPLICATIONS

Low Drift Integrator With Reset

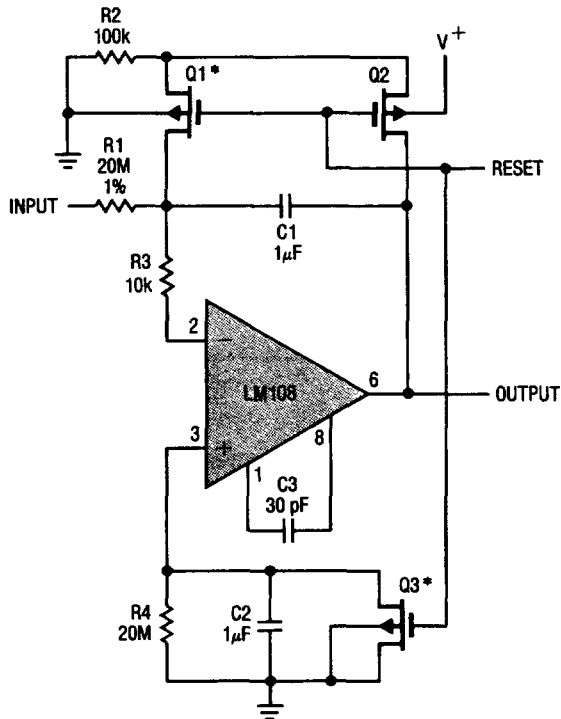

* Q1 AND Q3 SHOULD NOT HAVE INTERNAL GATE-PROTECTION DIODES.

Inverting Amplifier With High Input Resistance

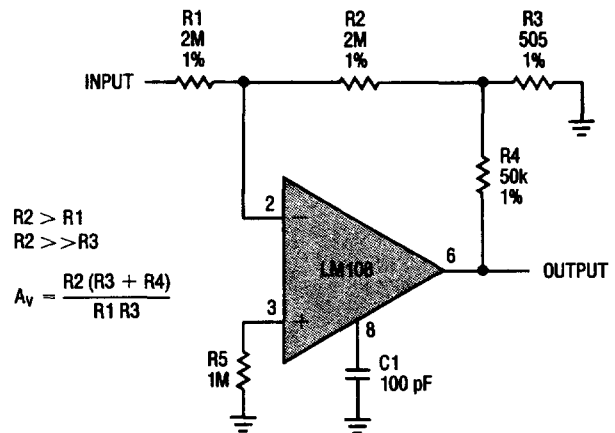

LM108A/LM308A LM108/LM308

TYPICAL APPLICATIONS

Amplifier For Piezoelectric Transducers

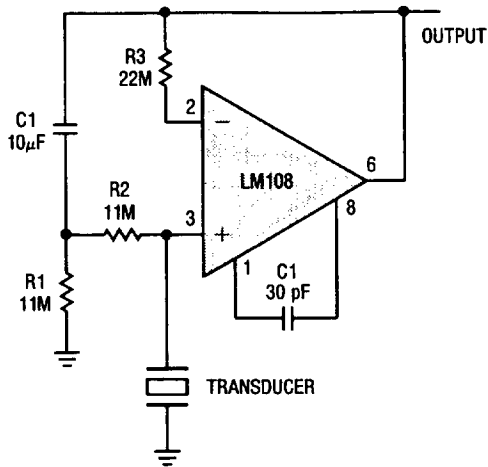

Amplifier For Bridge Transducers

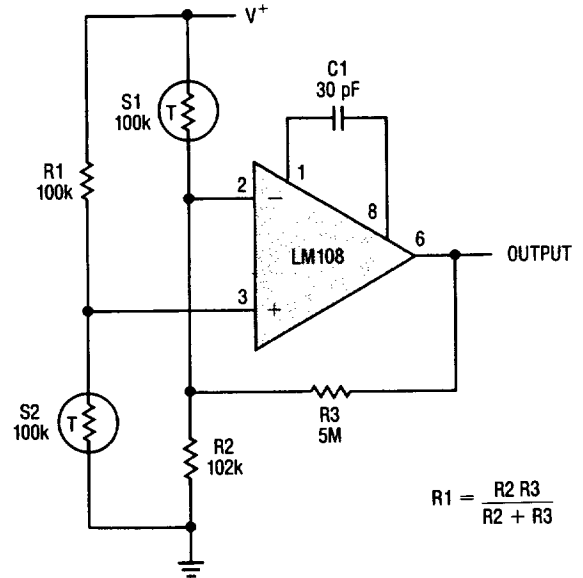

$$R1 = \frac{R2 R3}{R2 + R3}$$

Fast* Summing Amplifier

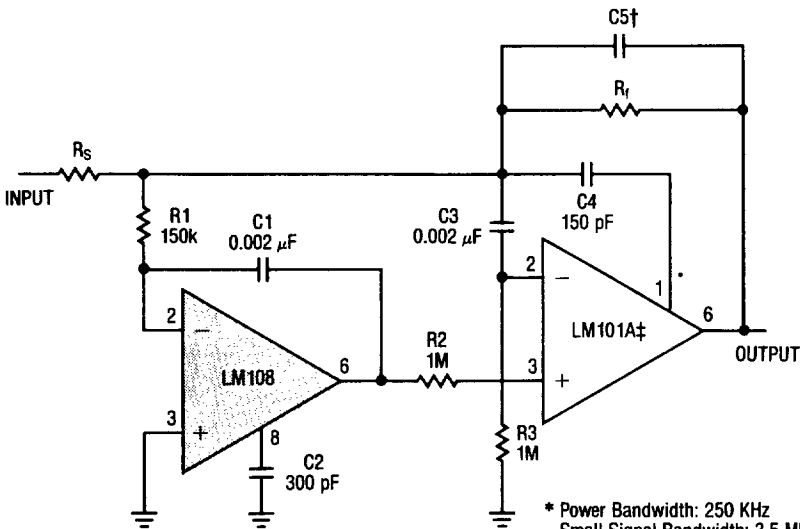

* Power Bandwidth: 250 KHz
Small Signal Bandwidth: 3.5 MHz
Slew Rate: 10V/µS

$$\uparrow C5 = \frac{6 \times 10^{-8}}{R_f}$$

‡ In addition to increasing speed, the LM101A raises high and low frequency gain, increases output drive capability and eliminates thermal feedback.

Bilateral Current Source

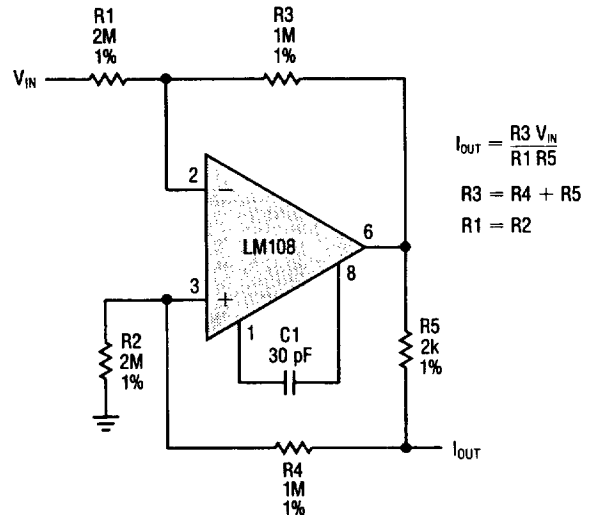

$$I_{out} = \frac{R3 V_{IN}}{R1 R5}$$

$$R3 = R4 + R5$$

$$R1 = R2$$

Sample and Hold

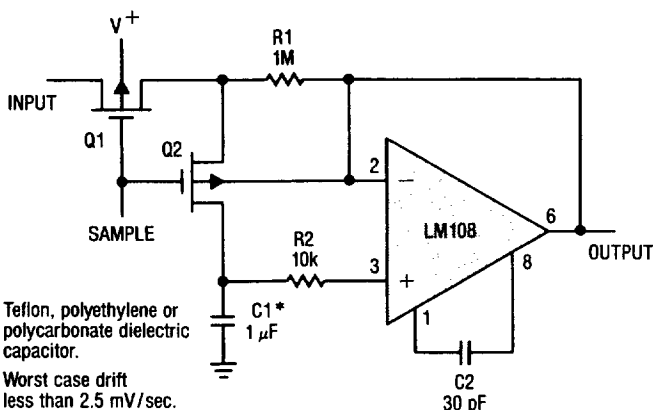

* Teflon, polyethylene or polycarbonate dielectric capacitor.

Worst case drift less than 2.5 mV/sec.

Differential Input Instrumentation Amplifier

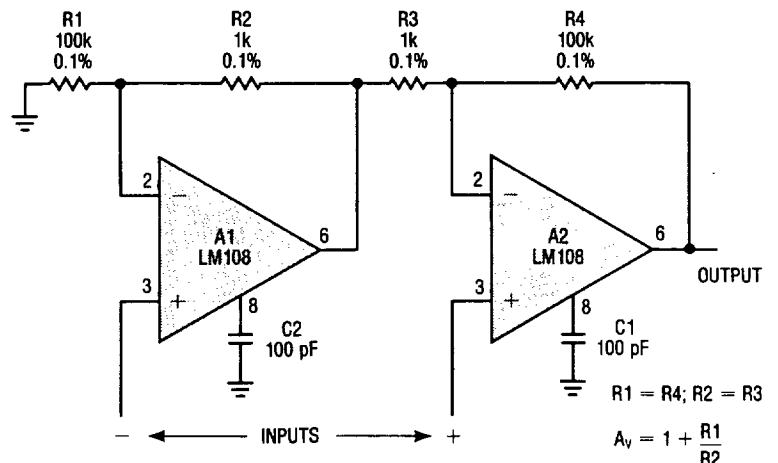

$$R1 = R4; R2 = R3$$

$$A_v = 1 + \frac{R1}{R2}$$

APPLICATIONS INFORMATION

Input guarding

Input guarding is used to reduce surface leakage. Guarding both sides of the board is required. Bulk leakage reduction is less and depends on the guard ring width.

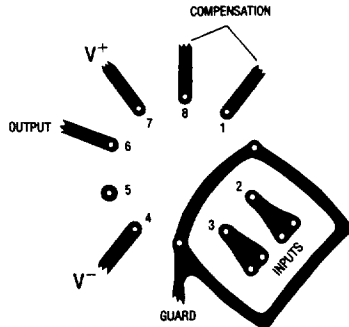

The guard ring is connected to a low impedance point at same potential as the sensitive input leads. Connections for various op amp configurations are shown below.

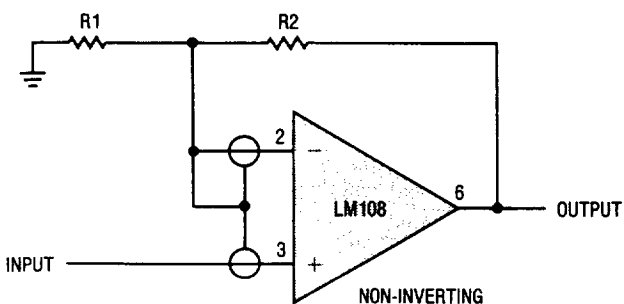
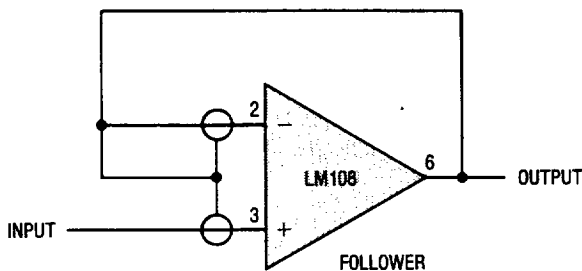
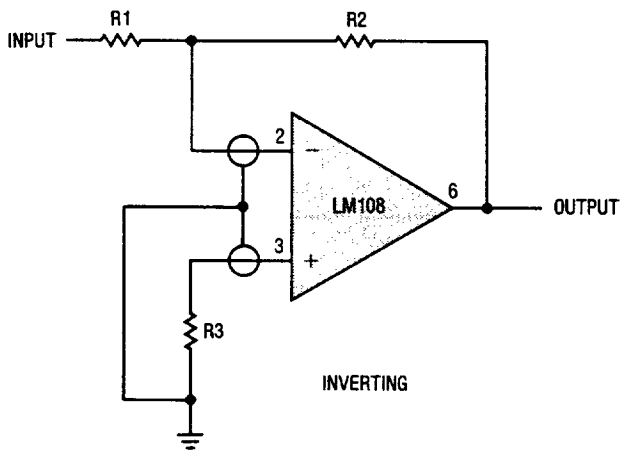

PN Input protection

Current is limited by R2 even when input is connected to a voltage source outside the common mode range. If one supply reverses, current is controlled by R1. These resistors do not affect normal operation.

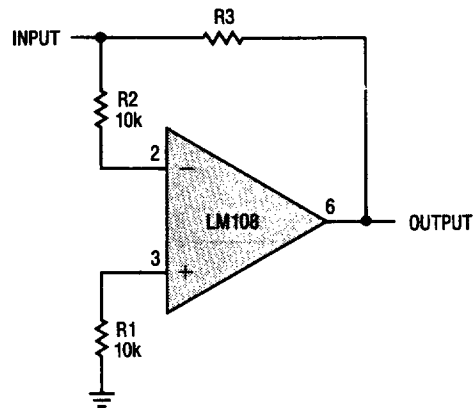

PN The input resistor controls the current when the input exceeds the supply voltages, when the power for the op amp is turned off, or when the output is shorted.

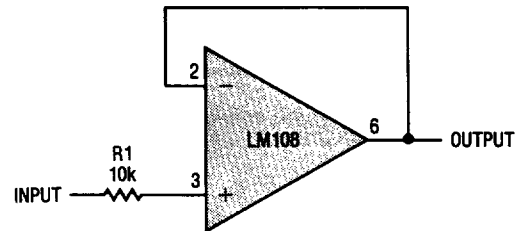

Offset Voltage Test Circuit†

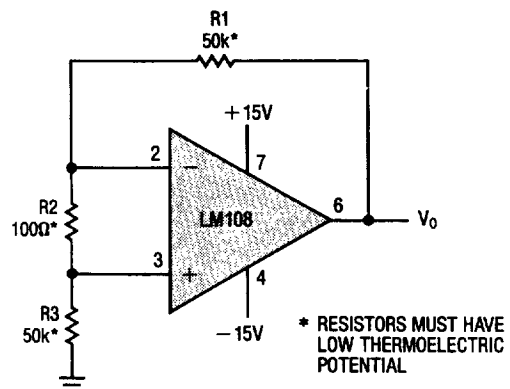

$A_v = 1000$

† THIS CIRCUIT IS ALSO USED AS THE BURN-IN CONFIGURATION WITH SUPPLY VOLTAGES EQUAL TO $\pm 20V$, $R1 = R3 = 10k$, $R2 = 200\Omega$, $A_v = 100$.

LM108A/LM308A LM108/LM308

SCHEMATIC DIAGRAM

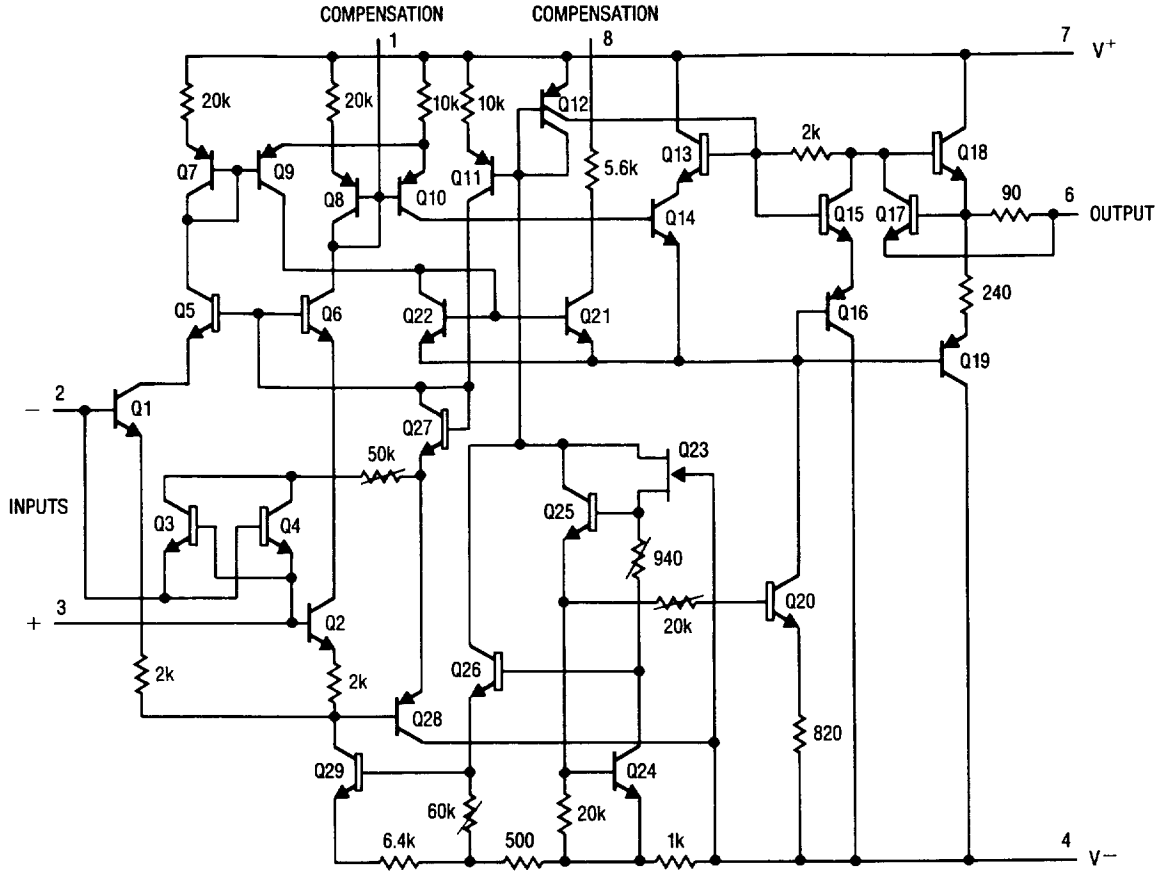

PACKAGE DESCRIPTION

**H Package
Metal Can**

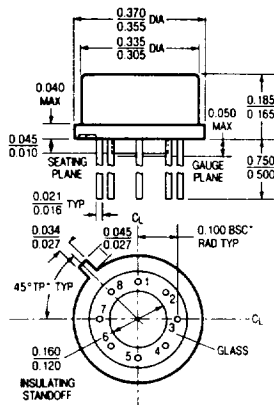

NOTE DIMENSIONS IN INCHES

T_j max	θ_{ja}	θ_{jc}
150°C	150°C/W	45°C/W

**N8 Package
8 Lead Plastic**

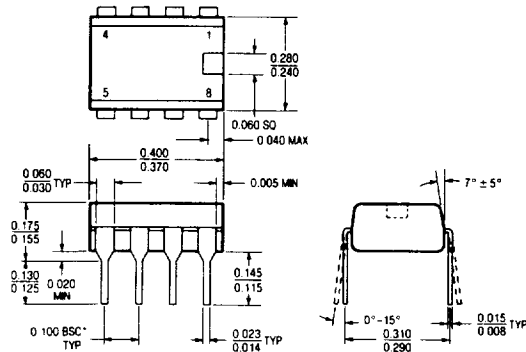

NOTE DIMENSIONS IN INCHES UNLESS OTHERWISE NOTED.
*LEADS WITHIN 0.007 OF TRUE POSITION (TP) AT GAUGE PLANE.

T_j max	θ_{ja}
100°C	130°C/W