

February 1995

LM221/LM321 Precision Preamplifiers

General Description

The LM221 series are precision preamplifiers designed to operate with general purpose operational amplifiers to drastically decrease dc errors. Drift, bias current, common mode and supply rejection are more than a factor of 50 better than standard op amps alone. Further, the added dc gain of the LM221 decreases the closed loop gain error.

The LM221 series operates with supply voltages from $\pm 3V$ to $\pm 20V$ and has sufficient supply rejection to operate from unregulated supplies. The operating current is programmable from $5 \mu A$ to $200 \mu A$ so bias current, offset current, gain and noise can be optimized for the particular application while still realizing very low drift. Super-gain transistors are used for the input stage so input error currents are lower than conventional amplifiers at the same operating current. Further, the initial offset voltage is easily nulled to zero.

The extremely low drift of the LM221 will improve accuracy on almost any precision dc circuit. For example, instrumentation amplifier, strain gauge amplifiers and thermocouple amplifiers now using chopper amplifiers can be made with

the LM221. The full differential input and high common-mode rejection are another advantage over choppers. For applications where low bias current is more important than drift, the operating current can be reduced to low values. High operating currents can be used for low voltage noise with low source resistance. The programmable operating current of the LM221 allows tailoring the input characteristics to match those of specialized op amps.

The LM221 is specified over a $-25^{\circ}C$ to $+85^{\circ}C$ range and the LM321 over a $0^{\circ}C$ to $+70^{\circ}C$ temperature range.

Features

- Guaranteed drift of LM321A— $0.2 \mu V/^{\circ}C$
- Guaranteed drift of LM221 series— $1 \mu V/^{\circ}C$
- Offset voltage less than $0.4 mV$
- Bias current less than $10 nA$ at $10 \mu A$ operating current
- CMRR 126 dB minimum
- 120 dB supply rejection
- Easily nulled offset voltage

Typical Applications

Thermocouple Amplifier with Cold Junction Compensation

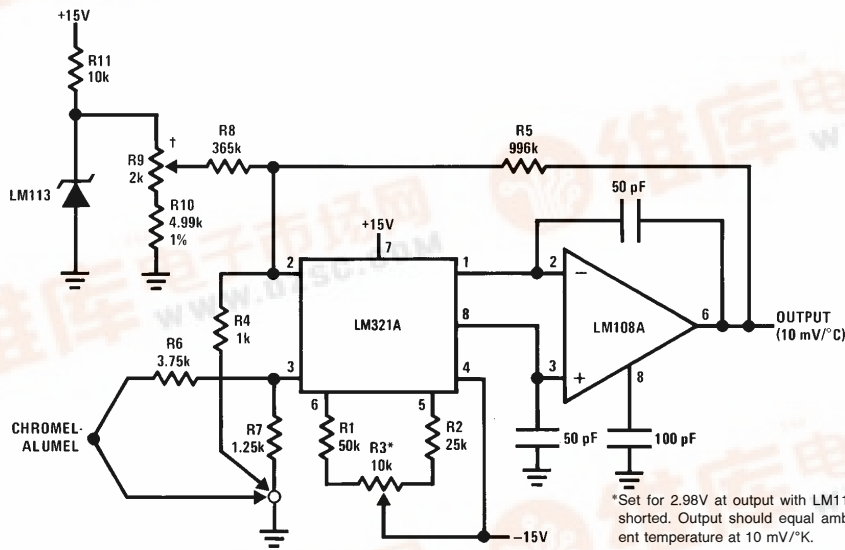

*Set for 2.98V at output with LM113 shorted. Output should equal ambient temperature at $10 mV/^{\circ}K$.

†Adjust for output reading in $^{\circ}C$. TL/H/7769-1

LM221/LM321 Precision Preamplifiers



Absolute Maximum Ratings

Supply Voltage	±20V	Operating Temperature Range	0°C to +70°C
Power Dissipation (Note 1)	500 mW	LM321A	
Differential Input Voltage (Notes 2 and 3)	±15V	Storage Temperature Range	−65°C to +150°C
Input Voltage (Note 3)	±15V	Lead Temperature (Soldering, 10 sec.)	300°C
		ESD rating to be determined.	

Electrical Characteristics (Note 4) LM321A

Parameter	Conditions	LM321A			Units
		Min	Typ	Max	
Input Offset Voltage	$T_A = 25^\circ\text{C}, 6.4\text{k} \leq R_{\text{SET}} \leq 70\text{k}$		0.2	0.4	mV
Input Offset Current	$T_A = 25^\circ\text{C},$ $R_{\text{SET}} = 70\text{k}$ $R_{\text{SET}} = 6.4\text{k}$		0.3	0.5 5	nA nA
Input Bias Current	$T_A = 25^\circ\text{C},$ $R_{\text{SET}} = 70\text{k}$ $R_{\text{SET}} = 6.4\text{k}$		5 50	15 150	nA nA
Input Resistance	$T_A = 25^\circ\text{C},$ $R_{\text{SET}} = 70\text{k}$ $R_{\text{SET}} = 6.4\text{k}$	2 0.2	8		MΩ MΩ
Supply Current	$T_A = 25^\circ\text{C}, R_{\text{SET}} = 70\text{k}$		0.8	2.2	mA
Input Offset Voltage	$6.4\text{k} \leq R_{\text{SET}} \leq 70\text{k}$		0.5	0.65	mV
Input Bias Current	$R_{\text{SET}} = 70\text{k}$ $R_{\text{SET}} = 6.4\text{k}$		15 150	25 250	nA nA
Input Offset Current	$R_{\text{SET}} = 70\text{k}$ $R_{\text{SET}} = 6.4\text{k}$		0.5 5	1 10	nA nA
Input Offset Current Drift	$R_{\text{SET}} = 70\text{k}$		3		pA/°C
Average Temperature	$R_S \leq 200\Omega, 6.4\text{k} \leq R_{\text{SET}} \leq 70\text{k}$				
Coefficient of Input Offset Voltage	Offset Voltage Nulled		0.07	0.2	μV/°C
Long Term Stability			3		μV/yr
Supply Current			1	3.5	mA
Input Voltage Range	$V_S = \pm 15\text{V},$ (Note 5) $R_{\text{SET}} = 70\text{k}$ $R_{\text{SET}} = 6.4\text{k}$	±13 +7, −13			V V
Common-Mode Rejection Ratio	$R_{\text{SET}} = 70\text{k}$ $R_{\text{SET}} = 6.4\text{k}$	126 120	140 130		dB dB
Supply Voltage Rejection Ratio	$R_{\text{SET}} = 70\text{k}$ $R_{\text{SET}} = 6.4\text{k}$	118 114	126 120		dB dB
Voltage Gain	$T_A = 25^\circ\text{C}, R_{\text{SET}} = 70\text{k},$ $R_L > 3\text{M}\Omega$	12	20		V/V
Noise	$R_{\text{SET}} = 70\text{k}, R_{\text{SOURCE}} = 0$		8		nV/√Hz

Note 1: The maximum junction temperature of the LM321A is 85°C. For operating at elevated temperature, devices in the H08 package must be derated based on a thermal resistance of 150°C/W, junction to ambient, or 18°C/W, junction to case.

Note 2: The inputs are shunted with back-to-back diodes in series with a 500Ω resistor for overvoltage protection. Therefore, excessive current will flow if a differential input voltage in excess of 1V is applied between the inputs.

Note 3: For supply voltages less than ±15V, the absolute maximum input voltage is equal to the supply voltage.

Note 4: These specifications apply for $\pm 5 \leq V_S \leq \pm 20\text{V}$ and $-55^\circ\text{C} \leq T_A \leq +125^\circ\text{C}$, unless otherwise specified. With the LM221A, however all temperature specifications are limited to $-25^\circ\text{C} \leq T_A \leq +85^\circ\text{C}$, and for the LM321A the specifications apply over a 0°C to +70°C temperature range.

Note 5: External precision resistor —0.1%— can be placed from pins 1 and 8 to 7 increase positive common-mode range.

Note 6: See RETS121X for LM121H/883 military specs and RET121AX for LM121AH/883 military specs.

Absolute Maximum Ratings

If Military/Aerospace specified devices are required, please contact the National Semiconductor Sales Office/Distributors for availability and specifications.

Supply Voltage	±20V
Power Dissipation (Note 1)	500 mW
Differential Input Voltage (Notes 2 and 3)	±15V
Input Voltage (Note 3)	±15V

Operating Temperature Range	LM221, LM121A (-883), LM121 (-883)	-25°C to +85°C
	LM321, LM321A	0°C to +70°C
Storage Temperature Range		-65°C to +150°C
Lead Temperature (Soldering, 10 sec.)		260°C
ESD rating to be determined.		

Electrical Characteristics (Note 4) LM221, LM321

Parameter	Conditions	LM221			LM321			Units
		Min	Typ	Max	Min	Typ	Max	
Input Offset Voltage	$T_A = 25^\circ\text{C}$, $6.4\text{k} \leq R_{\text{SET}} \leq 70\text{k}$			0.7			1.5	mV
Input Offset Current	$T_A = 25^\circ\text{C}$, $R_{\text{SET}} = 70\text{k}$ $R_{\text{SET}} = 6.4\text{k}$			1 10			2 20	nA nA
Input Bias Current	$T_A = 25^\circ\text{C}$, $R_{\text{SET}} = 70\text{k}$ $R_{\text{SET}} = 6.4\text{k}$			10 100			18 180	nA nA
Input Resistance	$T_A = 25^\circ\text{C}$, $R_{\text{SET}} = 70\text{k}$ $R_{\text{SET}} = 6.4\text{k}$	4 0.4			2 0.2			MΩ MΩ
Supply Current	$T_A = 25^\circ\text{C}$, $R_{\text{SET}} = 70\text{k}$			1.5			2.2	mA
Input Offset Voltage	$6.4\text{k} \leq R_{\text{SET}} \leq 70\text{k}$			1.0			2.5	mV
Input Bias Current	$R_{\text{SET}} = 70\text{k}$ $R_{\text{SET}} = 6.4\text{k}$			30 300			28 280	nA nA
Input Offset Current	$R_{\text{SET}} = 70\text{k}$ $R_{\text{SET}} = 6.4\text{k}$			3 30			4 40	nA nA
Input Offset Current Drift	$R_{\text{SET}} = 70\text{k}$		3			3		pA/°C
Average Temperature Coefficient of Input Offset Voltage	$R_S \leq 200\Omega$, $6.4\text{k} \leq R_{\text{SET}} \leq 70\text{k}$ Offset Voltage Nulled			1			1	μV/°C
Long Term Stability			5			5		μV/yr
Supply Current				2.5			3.5	mA
Input Voltage Range	$V_S = \pm 15\text{V}$, (Note 5) $R_{\text{SET}} = 70\text{k}$ $R_{\text{SET}} = 6.4\text{k}$	±13 +7, -13			±13 +7, -13			V V
Common-Mode Rejection Ratio	$R_{\text{SET}} = 70\text{k}$ $R_{\text{SET}} = 6.4\text{k}$	120 114			114 114			dB dB
Supply Voltage Rejection Ratio	$R_{\text{SET}} = 70\text{k}$ $R_{\text{SET}} = 6.4\text{k}$	120 114			114 114			dB dB
Voltage Gain	$T_A = 25^\circ\text{C}$, $R_{\text{SET}} = 70\text{k}$, $R_L > 3\text{M}\Omega$	16			12			V/V
Noise	$R_{\text{SET}} = 70\text{k}$, $R_{\text{SOURCE}} = 0$		8			8		nV/√Hz

Note 1: The maximum junction temperature of the LM221 is 100°C. The maximum junction temperature of the LM321 is 85°C. For operating at elevated temperature, devices in the H08 package must be derated based on a thermal resistance of 150°C/W, junction to ambient, or 18°C/W, junction to case.

Note 2: The inputs are shunted with back-to-back diodes in series with a 500Ω resistor for overvoltage protection. Therefore, excessive current will flow if a differential input voltage in excess of 1V is applied between the inputs.

Note 3: For supply voltages less than ±15V, the absolute maximum input voltage is equal to the supply voltage.

Note 4: These specifications apply for $\pm 5 \leq V_S \leq \pm 20\text{V}$ and $-55^\circ\text{C} \leq T_A \leq +125^\circ\text{C}$, unless otherwise specified. With the LM221, however all temperature specifications are limited to $-25^\circ\text{C} \leq T_A \leq +85^\circ\text{C}$, and for the LM321 the specifications apply over a 0°C to +70°C temperature range.

Note 5: External precision resistor —0.1%— can be placed from pins 1 and 8 to 7 increase positive common-mode range.

Typical Performance Characteristics

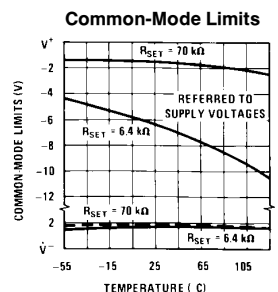
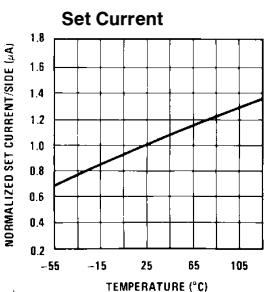
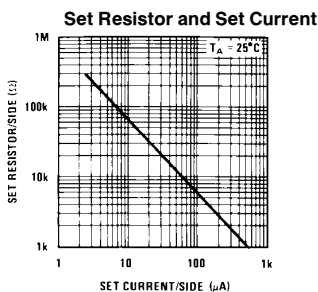
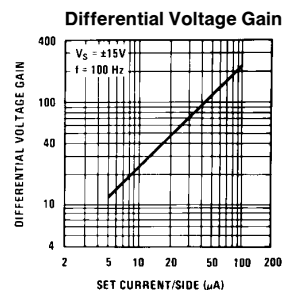
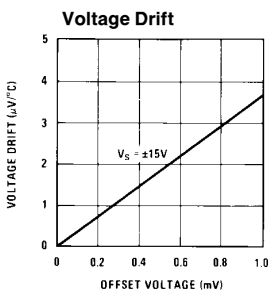
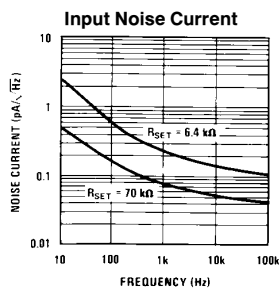
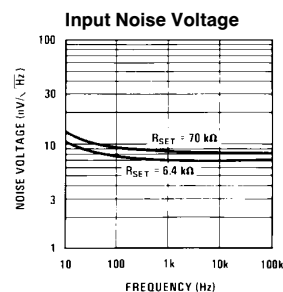
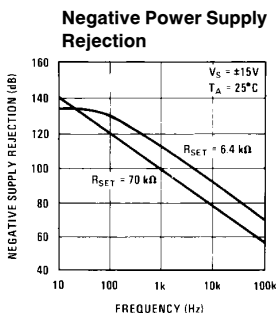
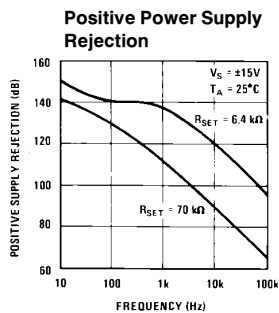
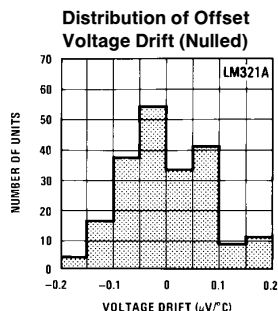
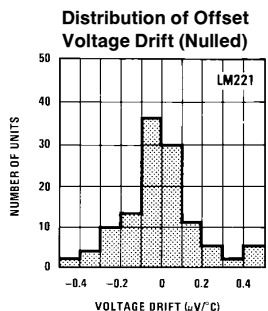
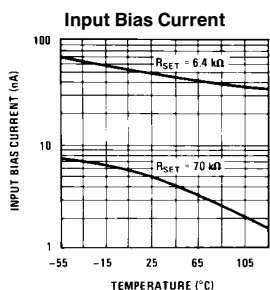

Typical Performance Characteristics (Continued)

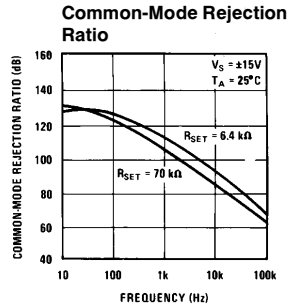
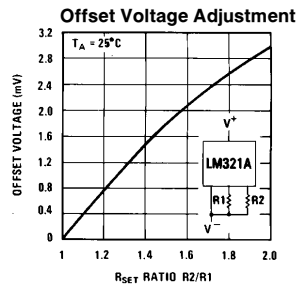
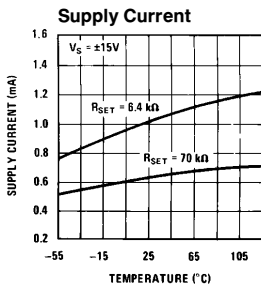
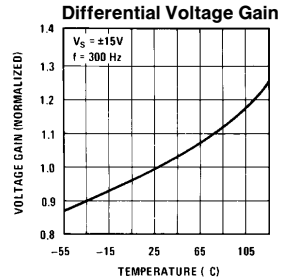
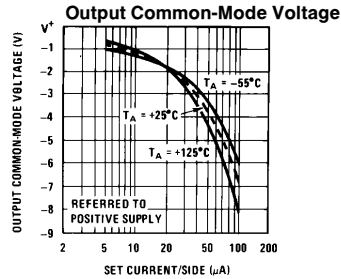
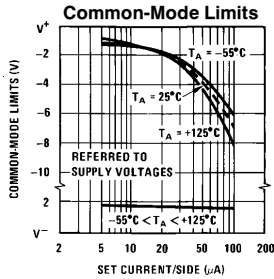

TL/H/7769-10

Connection Diagram

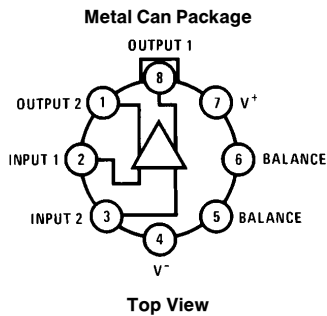

TL/H/7769-7

Note: Pin 4 connected to case.

Order Number LM121AH/883, LM121H/883,
 LM221H, LM321H or LM321AH
 See NS Package Number H08C

Note: Outputs are inverting from the input of the same number.

Schematic Diagram

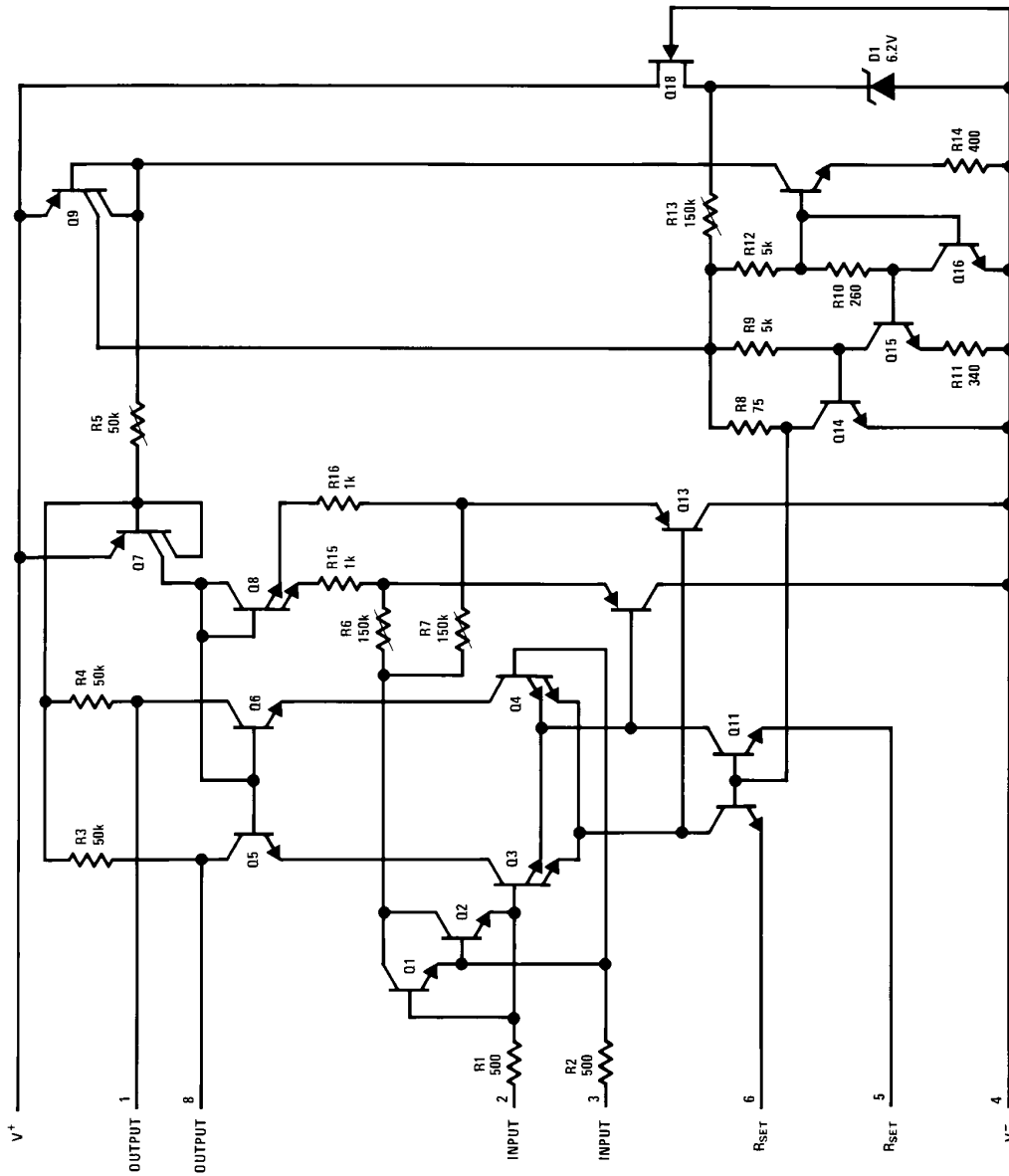

TL/H/7769-8

Frequency Compensation

UNIVERSAL COMPENSATION

The additional gain of the LM321 preamplifier when used with an operational amplifier usually necessitates additional frequency compensation. When the closed loop gain of the op amp with the LM321 is less than the gain of the LM321 alone, more compensation is needed. The worst case situation is when there is 100% feedback—such as a voltage follower or integrator—and the gain of the LM321 is high. When high closed loop gains are used—for example $A_V = 1000$ —and only an addition gain of 200 is inserted by the LM321, the frequency compensation of the op amp will usually suffice.

The frequency compensation shown here is designed to operate with any unity-gain stable op amp. Figure 1 shows the basic configuration of frequency stabilizing network. In operation the output of the LM321 is rendered single ended by a $0.01 \mu\text{F}$ bypass capacitor to ground. Overall frequency compensation then is achieved by an integrating capacitor around the op amp.

$$\text{Bandwidth at unity-gain} \approx \frac{12}{2\pi R_{\text{SET}} C}$$

$$\text{for } 0.5 \text{ MHz bandwidth } C = \frac{4}{10^6 R_{\text{SET}}}$$

For use with higher frequency op amps such as the LM118 the bandwidth may be increased to about 2 MHz.

If the closed loop gain is greater than unity, "C" may be decreased to:

$$C = \frac{4}{10^6 A_{\text{CL}} R_{\text{SET}}}$$

ALTERNATE COMPENSATION

The two compensation capacitors can be made equal for improved power supply rejection. In this case the formula for the compensation capacitor is:

$$C = \frac{8}{10^6 A_{\text{CL}} R_{\text{SET}}}$$

Typical Applications

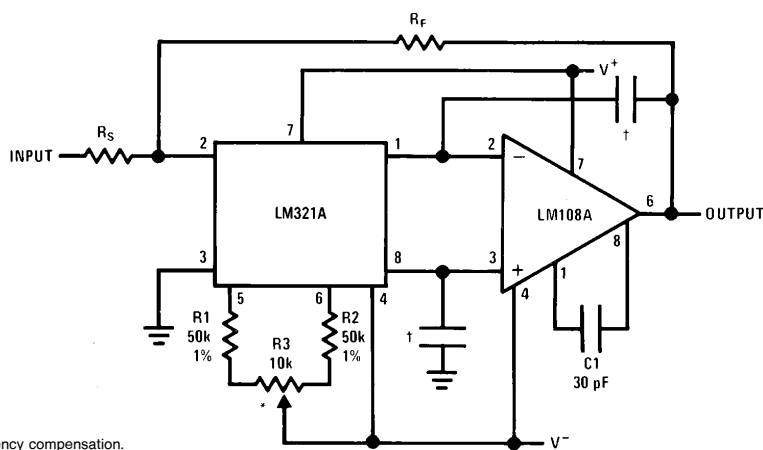

*Offset adjust.

†See table for frequency compensation.

FIGURE 1. Low Drift Op Amp Using the LM321A as a Preamp

Table I shows typical values for the two compensating capacitors for various gains and operating currents.

TABLE I

Closed Loop Gain	Current Set Resistor				
	120 k Ω	60 k Ω	30 k Ω	12 k Ω	6 k Ω
$A_V = 1$	68	130	270	680	1300
$A_V = 5$	15	27	56	130	270
$A_V = 10$	10	15	27	68	130
$A_V = 50$	1	3	5	15	27
$A_V = 100$	—	1	3	5	10
$A_V = 500$	—	—	1	1	3
$A_V = 1000$	—	—	—	—	—

This table applies for the LM108, LM101A, LM741, LM118. Capacitance is in pF.

DESIGN EQUATIONS FOR THE LM321 SERIES

$$\text{Gain } A_V \approx \frac{1.2 \times 10^6}{R_{\text{SET}}}$$

Null Pot Value should be 10% of R_{SET}

$$\text{Operating Current} \approx \frac{2 \times 0.65V}{R_{\text{SET}}}$$

$$\text{Positive Common-Mode Limit} \approx V^+ - \left[0.6 - \frac{0.65V \times 50k}{R_{\text{SET}}} \right]$$

TL/H/7769-2

Typical Applications (Continued)

Gain of 1000 Instrumentation Amplifier[‡]

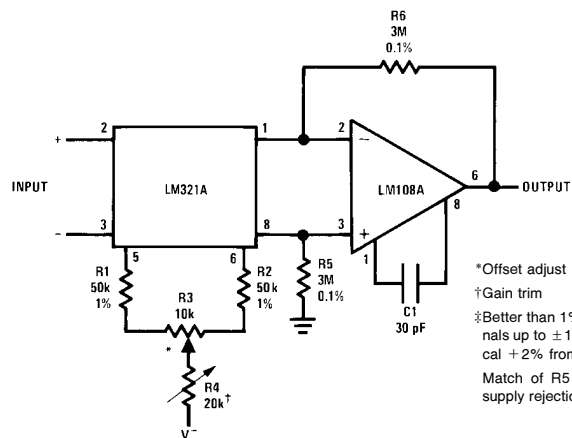

TL/H/7769-3

High Speed* Inverting Amplifier with Low Drift

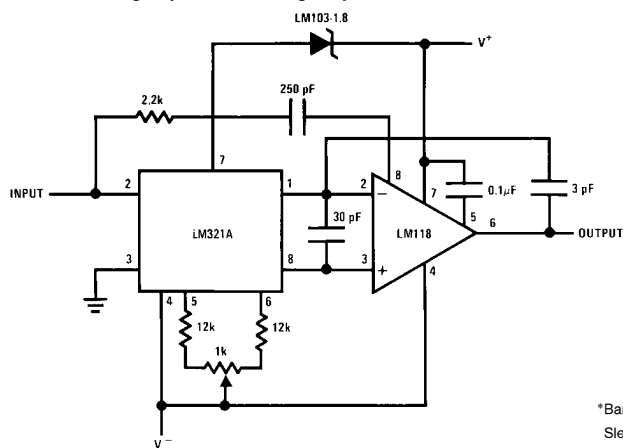

TL/H/7769-4

Medium Speed* General Purpose Amplifier

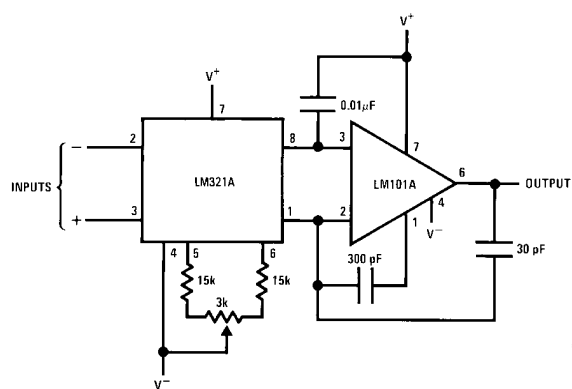

TL/H/7769-5

Typical Applications (Continued)

Increased Common-Mode Range at High Operating Currents

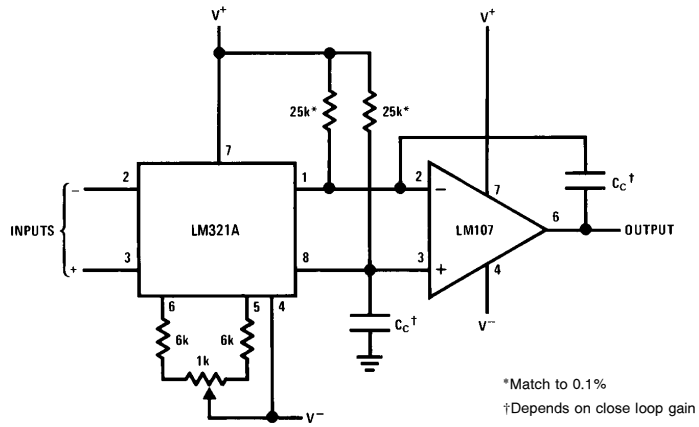

TL/H/7769-6

Physical Dimensions inches (millimeters)

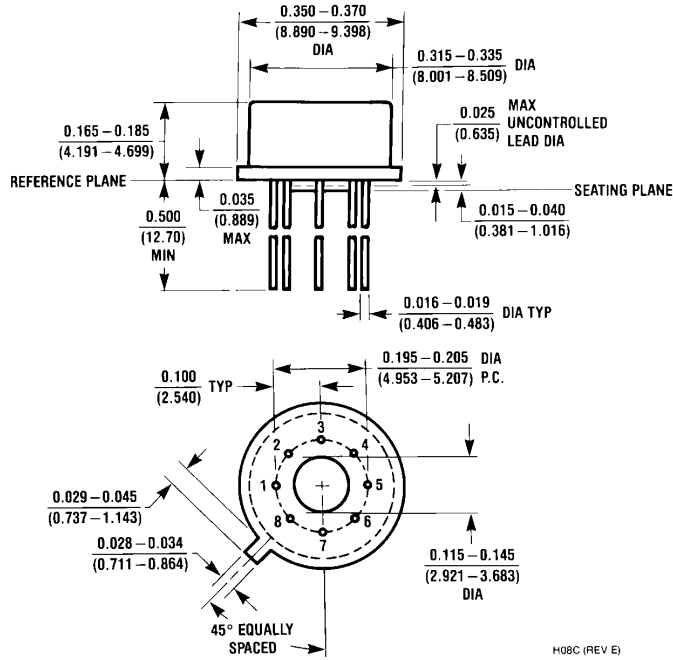

Metal Can Package (H)
Order Number LM221H, LM321H or LM321AH
NS Package Number H08C

H08C (REV E)

LIFE SUPPORT POLICY

NATIONAL'S PRODUCTS ARE NOT AUTHORIZED FOR USE AS CRITICAL COMPONENTS IN LIFE SUPPORT DEVICES OR SYSTEMS WITHOUT THE EXPRESS WRITTEN APPROVAL OF THE PRESIDENT OF NATIONAL SEMICONDUCTOR CORPORATION. As used herein:

1. Life support devices or systems are devices or systems which, (a) are intended for surgical implant into the body, or (b) support or sustain life, and whose failure to perform, when properly used in accordance with instructions for use provided in the labeling, can be reasonably expected to result in a significant injury to the user.
2. A critical component is any component of a life support device or system whose failure to perform can be reasonably expected to cause the failure of the life support device or system, or to affect its safety or effectiveness.



National Semiconductor Corporation
 1111 West Bardin Road
 Arlington, TX 76017
 Tel: 1(800) 272-9959
 Fax: 1(800) 737-7018

National Semiconductor Europe
 Fax: (+49) 0-180-530 85 86
 Email: cnjwge@tevm2.nsc.com
 Deutsch Tel: (+49) 0-180-530 85 85
 English Tel: (+49) 0-180-532 78 32
 Français Tel: (+49) 0-180-532 93 58
 Italiano Tel: (+49) 0-180-534 16 80

National Semiconductor Hong Kong Ltd.
 13th Floor, Straight Block,
 Ocean Centre, 5 Canton Rd.
 Tsimshatsui, Kowloon
 Hong Kong
 Tel: (852) 2737-1600
 Fax: (852) 2736-9960

National Semiconductor Japan Ltd.
 Tel: 81-043-299-2309
 Fax: 81-043-299-2408

This datasheet has been download from:

www.datasheetcatalog.com

Datasheets for electronics components.