



**PRELIMINARY**  
November 1999

## LMX2324 PLLatinum™ 2.0 GHz Frequency Synthesizer for RF Personal Communications

### General Description

The LMX2324 is a high performance frequency synthesizer with integrated 32/33 dual modulus prescaler designed for RF operation up to 2.0 GHz. Using a proprietary digital phase locked loop technique, the LMX2324's linear phase detector characteristics can generate very stable, low noise control signals for UHF and VHF voltage controlled oscillators.

Serial data is transferred into the LMX2324 via a three-line MICROWIRE™ interface (Data, LE, Clock). Supply voltage range is from 2.7V to 5.5V. The LMX2324 features very low current consumption, typically 3.5 mA at 3V. The charge pump provides 4 mA output current.

The LMX2324 is manufactured using National's ABiC V BiCMOS process and is packaged in a 16-pin TSSOP and a 16-pin Chip Scale Package (CSP).

### Features

- RF operation up to 2.0 GHz
- 2.7V to 5.5V operation
- Low current consumption:  $I_{CC} = 3.5 \text{ mA}$  (typ) at  $V_{CC} = 3.0\text{V}$
- Dual modulus prescaler: 32/33
- Internal balanced, low leakage charge pump

### Applications

- Cellular telephone systems (GSM, NADC, CDMA, PDC)
- Personal wireless communications (DCS-1800, DECT, CT-1+)
- Wireless local area networks (WLANs)
- Other wireless communication systems

### Functional Block Diagram

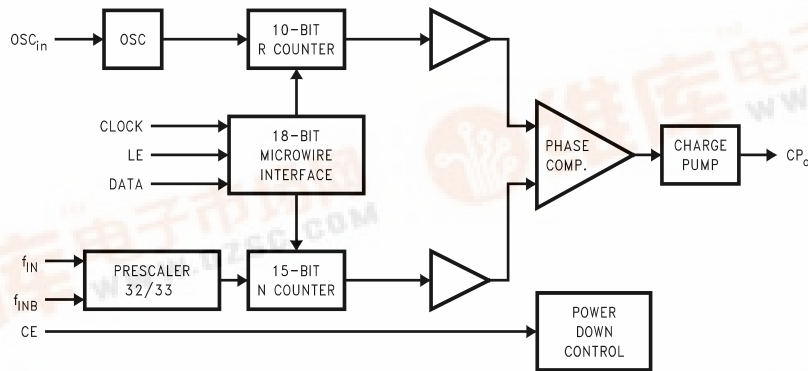

DS101030-1

TRI-STATE® is a registered trademark of National Semiconductor Corporation.  
MICROWIRE™ and PLLatinum™ are trademarks of National Semiconductor Corporation.



## Connection Diagrams

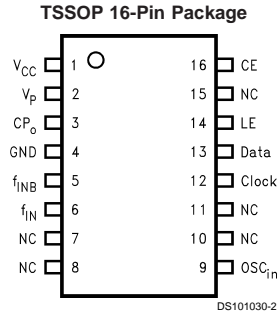

Order Number LMX2324TM, LM2324TMX  
See NS Package Number MTC16

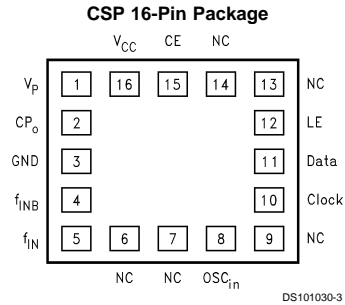

Top View  
Order Number LMX2324SLBX  
See NS Package Number SLB16A

## Pin Descriptions

Pin No.		Pin Name	I/O	Description
TSSOP16	CSP16			
2	1	$V_P$	—	Power supply for charge pump. Must be $\geq V_{CC}$
3	2	$CP_o$	O	Internal charge pump output. For connection to a loop filter for driving the voltage control input of an external oscillator.
4	3	GND	—	Ground.
5	4	$f_{INB}$	I	RF prescaler complimentary input. In single-ended mode, a bypass capacitor should be placed as close as possible to this pin and be connected directly to the ground plane. The LMX2324 can be driven differentially when the bypass capacitor is omitted.
6	5	$f_{IN}$	I	RF prescaler input. Small signal input from the voltage controlled oscillator.
7	6	NC		No Connect
8	7	NC		No Connect
9	8	$OSC_{in}$	I	Oscillator input. A CMOS inverting gate input. The input has a $V_{CC}/2$ input threshold and can be driven from an external CMOS or TTL logic gate.
10	9	NC		No Connect
12	10	Clock	I	High impedance CMOS Clock input. Data is clocked in on the rising edge, into the various counters and registers.
13	11	Data	I	Binary serial data input. Data entered MSB first. LSB is control bit. High impedance CMOS input.
14	12	LE	I	Load Enable input. When Load Enable transitions HIGH, data is loaded into either the N or R register (control bit dependent). See timing diagram.
15	13	NC		No Connect
11	14	NC		No Connect
16	15	CE	I	CHIP Enable. A LOW on CE powers down the device asynchronously and will TRI-STATE® the charge pump output.
1	16	$V_{CC}$	I	Power supply voltage input. Input may range from 2.7V to 5.5V. Bypass capacitors should be placed as close as possible to this pin and be connected directly to the ground plane.

**Absolute Maximum Ratings** (Note 1)

If Military/Aerospace specified devices are required, please contact the National Semiconductor Sales Office/ Distributors for availability and specifications.

Power Supply Voltage ( $V_{CC}$ )	-0.3V to 6.5V
Power Supply for Charge Pump ( $V_P$ )	$V_{CC}$ to 6.5V
Voltage on Any Pin with GND = 0V ( $V_I$ )	-0.3V to $V_{CC} + 0.3V$
Storage Temperature Range ( $T_S$ )	-65°C to +150°C
Lead Temperature (solder, 4 sec.) ( $T_L$ )	+260°C
ESD - Human Body Model (Note 2)	2 kV

**Recommended Operating Conditions** (Note 1)

Power Supply Voltage ( $V_{CC}$ )	2.7V to 5.5V
Power Supply for Charge Pump ( $V_P$ )	$V_{CC}$ to 5.5V
Operating Temperature ( $T_A$ )	-40°C to +85°C

**Note 1:** Absolute Maximum Ratings indicate limits beyond which damage to the device may occur. Recommended Operating Conditions indicate conditions for which the device is intended to be functional, but do not guarantee specific performance limits. For guaranteed specifications and test conditions, see the Electrical Characteristics.

**Note 2:** This device is a high performance RF integrated circuit and is ESD sensitive. Handling and assembly of this device should on be done on ESD protected workstations.

**Electrical Characteristics** ( $V_{CC} = 3V$ ,  $V_P = 3V$ ; -40°C <  $T_A$  < 85°C except as specified).

Symbol	Parameter	Conditions	Min	Typ	Max	Units
<b>GENERAL</b>						
$I_{CC}$	Power Supply Current	$V_{CC} = 2.7V$ to 5.5V		3.5		mA
$I_{CC-PWDN}$	Power Down Current			10		μA
$f_{IN}$	$f_{IN}$ Operating Frequency		0.1		2.0	GHz
$OSC_{in}$	Oscillator Operating Frequency		5		40	MHz
$f_{PD}$	Phase Detector Frequency				10	MHz
$Pf_{IN}$	Input Sensitivity $f_{INB}$ grounded through a 10 pF capacitor	$V_{CC} = 3.0V$ $V_{CC} = 5.0V$	-15 -10		0 0	dBm
$V_{OSC}$	Oscillator Sensitivity		0.4	1.0	$V_{CC}-0.3$	$V_{PP}$
<b>CHARGE PUMP</b>						
$ICP_{o-source}$	Charge Pump Output Current	$VCP_o = V_P/2$		-4.0		mA
$ICP_{o-sink}$				4.0		mA
$ICP_{o-Tri}$	Charge Pump TRI-STATE Current	$0.5 \leq VCP_o \leq V_P - 0.5$ $T = 25^\circ C$		0.1		nA
$ICP_o$ vs. $VCP_o$	Charge Pump Output Current Variation vs. Voltage (Note 4)	$0.5 \leq VCP_o \leq V_P - 0.5$ $T = 25^\circ C$		10		%
$ICP_{o-sink}$ vs. $ICP_{o-source}$	Charge Pump Output Current Sink vs. Source Mismatch (Note 4)	$VCP_o = V_P/2$ $T = 25^\circ C$		5		%
$ICP_o$ vs. T	Charge Pump Output Current Magnitude Variation vs. Temperature (Note 4)	$VCP_o = V_P/2$ $-40^\circ C \leq T \leq +85^\circ C$		10		%
<b>DIGITAL INTERFACE (DATA, CLK, LE, CE)</b>						
$V_{IH}$	High-Level Input Voltage	(Note 3)	0.8 $V_{CC}$			V
$V_{IL}$	Low-Level Input Voltage	(Note 3)			0.2 $V_{CC}$	V
$I_{IH}$	High-Level Input Current	$V_{IH} = V_{CC} = 5.5V$	-1.0		1.0	μA
$I_{IL}$	Low-Level Input Current	$V_{IL} = 0$ , $V_{CC} = 5.5V$	-1.0		1.0	μA
$I_{IH}$	Oscillator Input Current	$V_{IH} = V_{CC} = 5.5V$			100	μA
$I_{IL}$		$V_{IL} = 0$ , $V_{CC} = 5.5V$	-100			μA
<b>MICROWIRE TIMING</b>						
$t_{CS}$	Data to Clock Set Up Time	See Data Input Timing	50			ns
$t_{CH}$	Data to Clock Hold Time	See Data Input Timing	10			ns
$t_{CWH}$	Clock Pulse Width High	See Data Input Timing	50			ns
$t_{CWL}$	Clock Pulse Width Low	See Data Input Timing	50			ns
$t_{ES}$	Clock to Enable Set Up Time	See Data Input Timing	50			ns
$t_{EW}$	Enable Pulse Width	See Data Input Timing	50			ns

**Note 3:** Except  $f_{IN}$  and  $OSC_{in}$

**Note 4:** See related equations in charge pump current specification definitions

### Charge Pump Current Specification Definitions

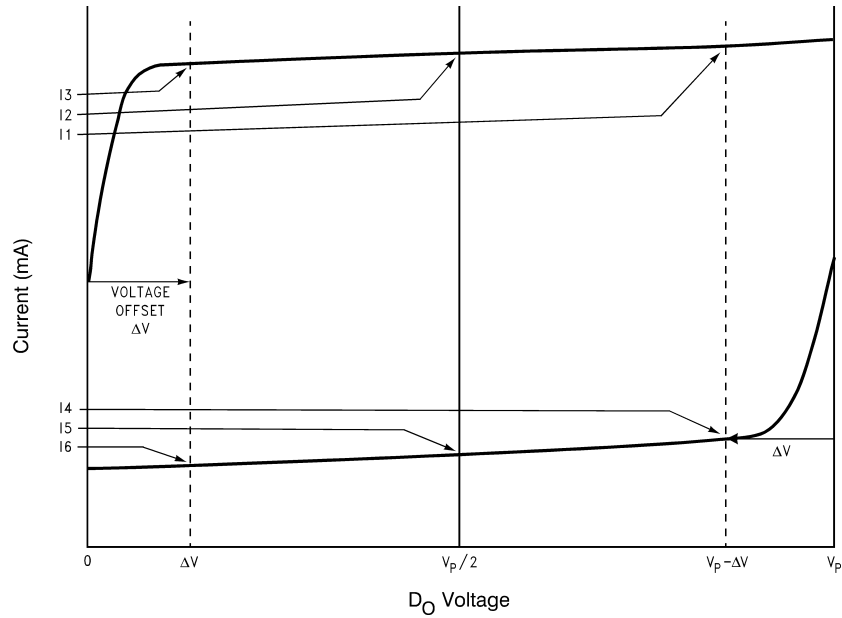

DS101030-4

- 11 = CP sink current at  $V_{CP0} = V_P - \Delta V$
- 12 = CP sink current at  $V_{CP0} = V_P/2$
- 13 = CP sink current at  $V_{CP0} = \Delta V$
- 14 = CP source current at  $V_{CP0} = V_P - \Delta V$
- 15 = CP source current at  $V_{CP0} = V_P/2$
- 16 = CP source current at  $V_{CP0} = \Delta V$

$\Delta V$  = Voltage offset from positive and negative rails. Dependent on VCO tuning range relative to  $V_P$  and ground. Typical values are between 0.5V and 1.0V.

1.  $ICP_o$  vs.  $V_{CP0}$  = Charge Pump Output Current magnitude variation vs. Voltage =  $[\frac{1}{2} * (|I1| - |I3|)] / [\frac{1}{2} * (|I1| + |I3|)] * 100\%$  and  $[\frac{1}{2} * (|I4| - |I6|)] / [\frac{1}{2} * (|I4| + |I6|)] * 100\%$
2.  $ICP_{o-sink}$  vs.  $ICP_{o-source}$  = Charge Pump Output Current Sink vs. Source Mismatch =  $[|I2| - |I5|] / [\frac{1}{2} * (|I2| + |I5|)] * 100\%$
3.  $ICP_o$  vs. T = Charge Pump Output Current magnitude variation vs. Temperature =  $[|I2 @ temp| - |I2 @ 25^\circ C|] / |I2 @ 25^\circ C| * 100\%$  and  $[|I5 @ temp| - |I5 @ 25^\circ C|] / |I5 @ 25^\circ C| * 100\%$

## 1.0 Functional Description

The basic phase-lock-loop (PLL) configuration consists of a high-stability crystal reference oscillator, a frequency synthesizer such as the National Semiconductor LMX2324, a voltage controlled oscillator (VCO), and a passive loop filter. The frequency synthesizer includes a phase detector, current mode charge pump, as well as programmable reference [R] and feedback [N] frequency dividers. The VCO frequency is established by dividing the crystal reference signal down via the R counter to obtain a frequency that sets the comparison frequency. This reference signal,  $f_r$ , is then presented to the input of a phase/frequency detector and compared with another signal,  $f_p$ , the feedback signal, which was obtained by dividing the VCO frequency down by way of the N counter. The phase/frequency detector's current source outputs pump charge into the loop filter, which then converts the charge into the VCO's control voltage. The phase/frequency comparator's function is to adjust the voltage presented to the VCO until the feedback signal's frequency (and phase) match that of the reference signal. When this "phase-locked" condition exists, the RF VCO's frequency will be N times that of the comparison frequency, where N is the divider ratio.

### 1.1 OSCILLATOR

The reference oscillator frequency for the PLL is provided by an external reference TCXO through the  $OSC_{in}$  pin.  $OSC_{in}$  block can operate to 40 MHz with a minimum input sensitivity of  $0.4V_{PP}$ . The inputs have a  $V_{CO}/2$  input threshold and can be driven from an external CMOS or TTL logic gate.

### 1.2 REFERENCE DIVIDERS (R COUNTER)

The R Counter is clocked through the oscillator block. The maximum frequency is 40 MHz. The R Counter is a 10 bit CMOS binary counters with a divide range from 2 to 1,023. See programming description 2.2.1.

### 1.3 PROGRAMMABLE DIVIDERS (N COUNTER)

The N counter is clocked by the small signal  $f_{IN}$  and  $f_{INB}$  input pins. The LMX2324 RF N counter is 15 bit integer divider. The N counter is configured as a 5 bit A Counter and a 10 bit B Counter, offering a continuous integer divide range from 992 to 32,767. The LMX2324 is capable of operating from 100 MHz to 2.0 GHz with a 32/33 prescaler.

#### 1.3.1 Prescaler

The RF inputs to the prescaler consist of the  $f_{IN}$  and  $f_{INB}$  pins which are the complimentary inputs of a differential pair amplifier. The differential  $f_{IN}$  configuration can operate to 2 GHz with an input sensitivity of  $-15$  dBm. The input buffer drives the N counter's ECL D-type flip flops in a dual modulus configuration. A 32/33 prescale ratio is provided for the LMX2324. The prescaler clocks the subsequent CMOS flip-flop chain comprising the fully programmable A and B counters.

### 1.4 PHASE/FREQUENCY DETECTOR

The phase/(frequency) detector is driven from the N and R counter outputs. The maximum frequency at the phase detector inputs is 10 MHz. The phase detector outputs control the charge pumps. The polarity of the pump-up or pump-down control is programmed using  $PD\_POL$ , depending on whether RF VCO characteristics are positive or negative (see programming description 2.2.2). The phase detector also receives a feedback signal from the charge pump, in order to eliminate dead zone.

### 1.5 CHARGE PUMP

The phase detector's current source output pumps charge into an external loop filter, which then converts the charge into the VCO's control voltage. The charge pumps steer the charge pump output,  $CP_o$ , to  $V_P$  (pump-up) or Ground (pump-down). When locked,  $CP_o$  is primarily in a TRI-STATE mode with small corrections. The RF charge pump output current magnitude is set to 4.0 mA. The charge pump output can also be used to output divider signals as detailed in section 2.2.3.

### 1.6 MICROWIRE SERIAL INTERFACE

The programmable functions are accessed through the MICROWIRE serial interface. The interface is made of three functions: clock, data and latch enable (LE). Serial data for the various counters is clocked in from data on the rising edge of clock, into the 18-bit shift register. Data is entered MSB first. The last bit decodes the internal register address. On the rising edge of LE, data stored in the shift register is loaded into one of the two appropriate latches (selected by address bits). A complete programming description is included in the following sections.

### 1.7 POWER CONTROL

The PLL can be power controlled in two ways. The first method is by setting the CE pin LOW. This asynchronously powers down the PLL and TRI-STATE the charge pump output, regardless of the PWDN bit status. The second method is by programming through MICROWIRE, while keeping the CE HIGH. Programming the PWDN bit in the N register HIGH (CE=HIGH) will disable the N counter and de-bias the  $f_{IN}$  input (to a high impedance state). The R counter functionality also becomes disabled. The reference oscillator block powers down when the power down bit is asserted. The  $OSC_{in}$  pin reverts to a high impedance state when this condition exists. Power down forces the charge pump and phase comparator logic to a TRI-STATE condition. A power down counter reset function resets both N and R counters. Upon powering up the N counter resumes counting in "close" alignment with the R counter (The maximum error is one prescaler cycle). The MICROWIRE control register remains active and capable of loading and latching in data during all of the power down modes.

## 2.0 Programming Description

### 2.1 MICROWIRE INTERFACE

The LMX2324 register set can be accessed through the MICROWIRE interface. A 18-bit shift register is used as a temporary register to indirectly program the on-chip registers. The shift register consists of a 17-bit DATA[16:0] field and a 1-bit address (ADDR) field as shown below. The address field is used to decode the internal register address. Data is clocked into the shift register in the direction from MSB to LSB, when the CLOCK signal goes high. On the rising edge of Load Enable (LE) signal, data stored in the shift register is loaded into the addressed latch.

MSB		LSB	
DATA[16:0]		ADDR	
17	1	0	

#### 2.1.1 Registers' Address Map

When Load Enable (LE) is transitioned high, data is transferred from the 18-bit shift register into the appropriate latch depending on the state of the ADDRESS bit. A multiplexing circuit decodes the address bit and writes the data field to the corresponding internal register.

REGISTER ADDRESSED	ADDRESS BIT ADDR
R Register	1
N Register	0

## 2.0 Programming Description (Continued)

### 2.1.2 Register Content Truth Table

Register	SHIFT REGISTER BIT LOCATION																MSB	LSB	
	17	16	15	14	13	12	11	10	9	8	7	6	5	4	3	2	1	0	
N	Data Field																ADDR Field		
	NB_CNTR[9:0]								NA_CNTR[4:0]				CTL_WORD[1:0]				0		
	X	X	X	TEST	RS	PD_POL	CP_TRI	R_CNTR[9:0]										1	
	R16	R15	R14	R13	R12	R11	R10	R9	R8	R7	R6	R5	R4	R3	R2	R1	R0		

### 2.2 R REGISTER

If the Address Bit (ADDR) is 1, when LE is transitioned high data is transferred from the 18-bit shift register into the 14-bit R register. The R register contains a latch which sets the PLL 10-bit R counter divide ratio. The divide ratio is programmed using the bits R\_CNTR as shown in table 2.2.1. The ratio must be  $\geq 2$ . The PD\_POL, CP\_TRI and TEST bits control the phase detector polarity, charge pump TRI-STATE, and test mode respectively, as shown in 2.2.2. The RS bit is reserved and should always be set to zero. X denotes a don't care condition. Data is clocked into the shift register MSB first.

Register	SHIFT REGISTER BIT LOCATION																MSB	LSB	
	17	16	15	14	13	12	11	10	9	8	7	6	5	4	3	2	1	0	
R	Data Field																ADDR Field		
	X	X	X	TEST	RS	PD_POL	CP_TRI	R_CNTR[9:0]										1	
	R16	R15	R14	R13	R12	R11	R10	R9	R8	R7	R6	R5	R4	R3	R2	R1	R0		

### 2.2.1 10-Bit Programmable Reference Divider Ratio (R Counter)

R_CNTR[9:0]										
Divide Ratio	R9	R8	R7	R6	R5	R4	R3	R2	R1	R0
2	0	0	0	0	0	0	0	0	1	0
3	0	0	0	0	0	0	0	0	1	1
•	•	•	•	•	•	•	•	•	•	•
1,023	1	1	1	1	1	1	1	1	1	1

**Notes:** Divide ratio: 2 to 1,023 (Divide ratios less than 2 are prohibited)  
R\_CNTR — These bits select the divide ratio of the programmable reference dividers.

### 2.2.2 R Register Truth Table

Bit	Location	Function	0	1
CP_TRI	R[10]	Charge Pump TRI-STATE	Normal Operation	TRI-STATE
PD_POL	R[11]	Phase Detector Polarity	Negative	Positive
TEST	R[13]	Test Mode Bit	Normal Operation	Test Mode

If the test mode is NOT activated (R[13]=0), the charge pump is active when CP\_TRI is set LOW. When CP\_TRI is set HIGH, the charge pump output and phase comparator are forced to a TRI-STATE condition. This bit must be set HIGH if the test mode is ACTIVATED (R[13]=1).

If the test mode is NOT activated (R[13]=0), PD\_POL sets the VCO characteristics to positive when set HIGH. When PD\_POL is set LOW, the VCO exhibits a negative characteristic where the VCO frequency decreases with increasing control voltage.

If the test mode is ACTIVATED (R[13]=1), the outputs of the N and R counters are directed to the CP<sub>o</sub> output to allow for testing. The PD\_POL bit selects which counter output according to Table 2.2.3.

### 2.2.3 Test Mode Truth Table (R[13] = 1)

CP <sub>o</sub> Output	CP_TRI R[10]	PD_POL R[11]
R Divider Output	1	0
N Divider Output	1	1

## 2.0 Programming Description (Continued)

### 2.3 N REGISTER

If the address bit is LOW (ADDR=0) when LE is transitioned high, data is transferred from the 18-bit shift register into the 17-bit N register. The N register consists of the 5-bit swallow counter (A counter), the 10-bit programmable counter (B counter) and the control word. Serial data format is shown below in tables 2.3.1 and 2.3.2. The pulse swallow function which determines the divide ratio is described in section 2.3.3. Data is clocked into the shift register MSB first.

	SHIFT REGISTER BIT LOCATION																LSB	
	17	16	15	14	13	12	11	10	9	8	7	6	5	4	3	2	1	0
Register	Data Field																ADDR Field	
N	NB_CNTR[9:0]										NA_CNTR[4:0]				CTL_WORD[1:0]		0	
	N16	N15	N14	N13	N12	N11	N10	N9	N8	N7	N6	N5	N4	N3	N2	N1	N0	

#### 2.3.1 5-Bit Swallow Counter Divide Ratio (A Counter)

Swallow Count	NA_CNTR[4:0]				
(A)	N6	N5	N4	N3	N2
0	0	0	0	0	0
1	0	0	0	0	1
•	•	•	•	•	•
31	1	1	1	1	1

**Notes:** Swallow Counter Value: 0 to 31  
 NB\_CNTR ≥ NA\_CNTR

#### 2.3.2 10-Bit Programmable Counter Divide Ratio (B Counter)

Divide Ratio	NB_CNTR[10:0]									
	N16	N15	N14	N13	N12	N11	N10	N9	N8	N7
3	0	0	0	0	0	0	0	0	1	1
4	0	0	0	0	0	0	0	1	0	0
•	•	•	•	•	•	•	•	•	•	•
1023	1	1	1	1	1	1	1	1	1	1

**Notes:** Divide ratio: 3 to 1,023 (Divide ratios less than 3 are prohibited)  
 NB\_CNTR ≥ NA\_CNTR

#### 2.3.3 Pulse Swallow Function

The N divider counts such that it divides the VCO RF frequency by (P+1) A times, and then divides by P (B - A) times. The B value (NB\_CNTR) must be ≥ 3. The continuous divider ratio is from 992 to 32,767. Divider ratios less than 992 are achievable as long as the binary counter value is greater than the swallow counter value (NB\_CNTR ≥ NA\_CNTR).

$$f_{VCO} = N \times (f_{OSC}/R)$$

$$N = (P \times B) + A$$

f<sub>VCO</sub>: Output frequency of external voltage controlled oscillator (VCO)

f<sub>OSC</sub>: Output frequency of the external reference frequency oscillator

R: Preset divide ratio of binary 10-bit programmable reference counter (2 to 1023)

N: Preset divide ratio of main 15-bit programmable integer N counter (992 to 32,767)

B: Preset divide ratio of binary 10-bit programmable B counter (3 to 1023)

A: Preset value of binary 5-bit swallow A counter (0 ≤ A ≤ 31, A ≤ B)

P: Preset modulus of dual modulus prescaler (P=32)

#### 2.3.4 CTL\_WORD

MSB		LSB
N1		N0
CNT_RST		PWDN



## 2.0 Programming Description (Continued)

### 2.3.4.1 Control Word Truth Table

CE	CNT_RST	PWDN	Function
1	0	0	Normal Operation
1	0	1	Synchronous Powerdown
1	1	0	Counter Reset
1	1	1	Asynchronous Powerdown
0	X	X	Asynchronous Powerdown

**Notes:** X denotes don't care.

The **Counter Reset** enable bit when activated allows the reset of both N and R counters. Upon powering up the N counter resumes counting in "close" alignment with the R counter. (The maximum error is one prescaler cycle).

Both synchronous and asynchronous **power down** modes are available with the LMX2324 to be able to adapt to different types of applications. The MICROWIRE control register remains active and capable of loading and latching in data during all of the powerdown modes.

#### Synchronous Power down Mode

The PLL loops can be synchronously powered down by setting the counter reset mode bit to LOW ( $N[1] = 0$ ) and its power down mode bit to HIGH ( $N[0] = 1$ ). The power down function is gated by the charge pump. Once the power down mode and counter reset mode bits are loaded, the part will go into power down mode upon the completion of a charge pump pulse event.

#### Asynchronous Power down Mode

The PLL loops can be asynchronously powered down by setting the counter reset mode bit to HIGH ( $N[1] = 1$ ) and its power down mode bit to HIGH ( $N[0] = 1$ ), or by setting CE pin LOW. The power down function is NOT gated by the charge pump. Once the power down and counter reset mode bits are loaded, the part will go into power down mode immediately.

The R and N counters are disabled and held at load point during the synchronous and asynchronous power down modes. This will allow a smooth acquisition of the RF signal when the PLL is programmed to power up. Upon powering up, both R and N counters will start at the 'zero' state, and the relationship between R and N will not be random.

## Serial Data Input Timing

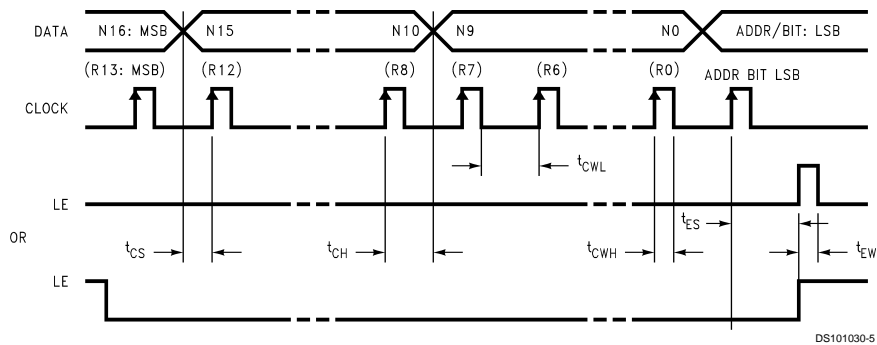

**Notes:** Parenthesis data indicates programmable reference divider data.

Data shifted into register on clock rising edge.

Data is shifted in MSB first.

**Test Conditions:** The Serial Data Input Timing is tested using a symmetrical waveform around  $V_{CC}/2$ . The test waveform has an edge rate of 0.6 V/ns with amplitudes of 1.6V @  $V_{CC} = 2.7V$  and 3.3V @  $V_{CC} = 5.5V$ .

### Phase Comparator and Internal Charge Pump Characteristics

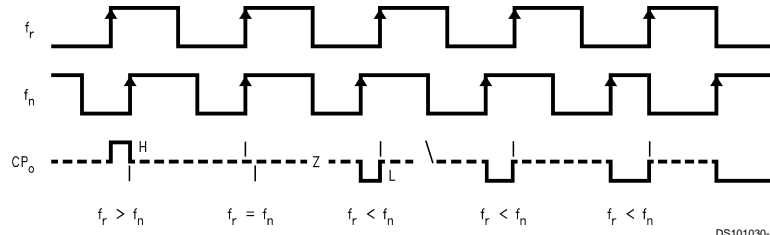

DS101030-6

**Notes:** Phase difference detection range:  $-2\pi$  to  $+2\pi$   
 The minimum width pump up and pump down current pulses occur at the  $CP_o$  pin when the loop is locked. PD\_POL = 1  
 $f_R$ : Phase comparator input from the R Divider  
 $f_N$ : Phase comparator input from the N divider  
 $CP_o$ : Charge pump output

**Physical Dimensions** inches (millimeters) unless otherwise noted

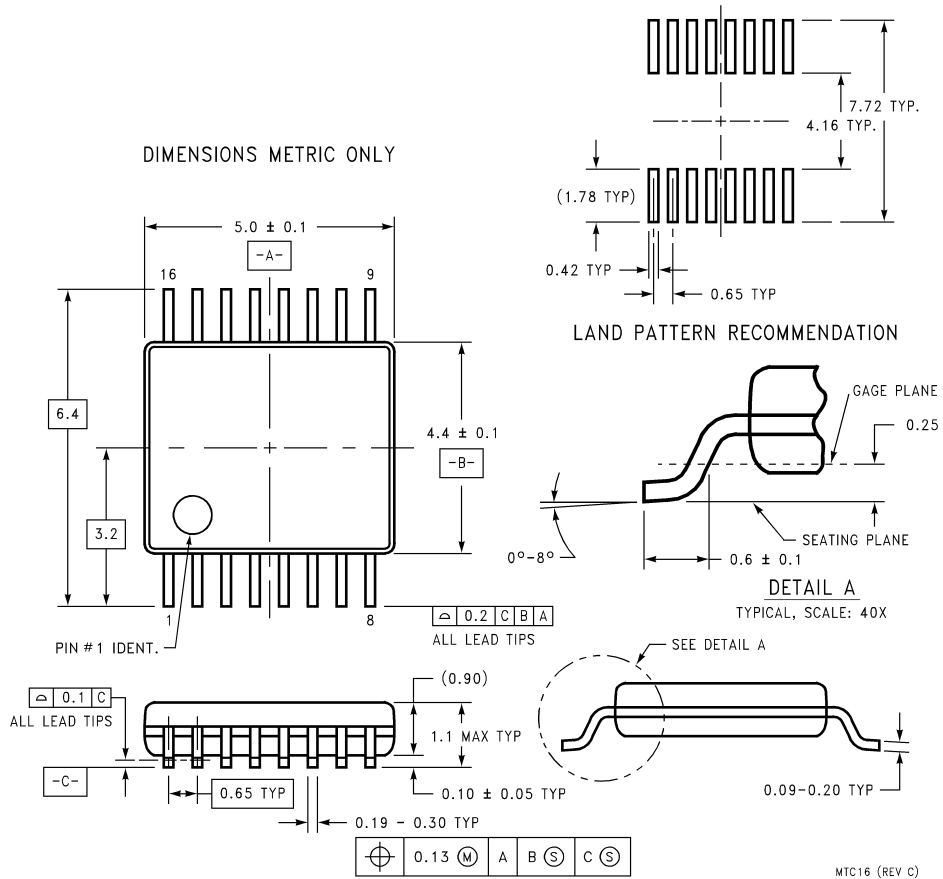

**16-Pin Thin Shrink Small Outline Package**  
**Order Number LMX2324TM, LMX2324TMX**  
**NS Package Number MTC16**

**Physical Dimensions** inches (millimeters) unless otherwise noted (Continued)

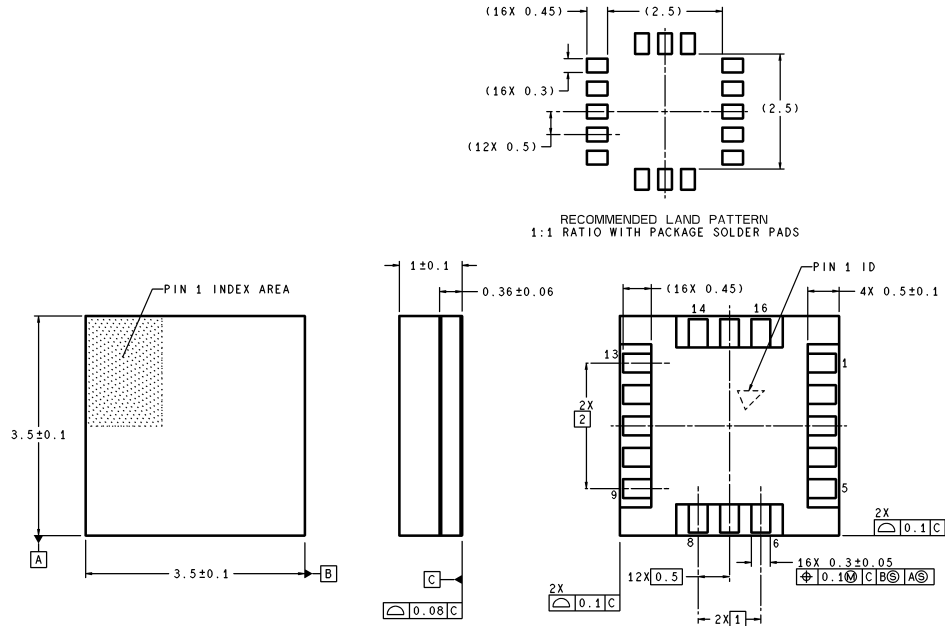

DIMENSIONS ARE IN MILLIMETERS

SLB16A (Rev B)

**16-Pin Chip Scale Package**  
**Order Number LMX2324SLBX**  
**NS Package Number SLB16A**

**LIFE SUPPORT POLICY**

NATIONAL'S PRODUCTS ARE NOT AUTHORIZED FOR USE AS CRITICAL COMPONENTS IN LIFE SUPPORT DEVICES OR SYSTEMS WITHOUT THE EXPRESS WRITTEN APPROVAL OF THE PRESIDENT AND GENERAL COUNSEL OF NATIONAL SEMICONDUCTOR CORPORATION. As used herein:

1. Life support devices or systems are devices or systems which, (a) are intended for surgical implant into the body, or (b) support or sustain life, and whose failure to perform when properly used in accordance with instructions for use provided in the labeling, can be reasonably expected to result in a significant injury to the user.
2. A critical component is any component of a life support device or system whose failure to perform can be reasonably expected to cause the failure of the life support device or system, or to affect its safety or effectiveness.



**National Semiconductor Corporation**  
 Americas  
 Tel: 1-800-272-9959  
 Fax: 1-800-737-7018  
 Email: support@nsc.com

www.national.com

**National Semiconductor Europe**  
 Fax: +49 (0) 1 80-530 85 86  
 Email: europe.support@nsc.com  
 Deutsch Tel: +49 (0) 1 80-530 85 85  
 English Tel: +49 (0) 1 80-532 78 32  
 Français Tel: +49 (0) 1 80-532 93 58  
 Italiano Tel: +49 (0) 1 80-534 16 80

**National Semiconductor Asia Pacific Customer Response Group**  
 Tel: 65-2544466  
 Fax: 65-2504466  
 Email: sea.support@nsc.com

**National Semiconductor Japan Ltd.**  
 Tel: 81-3-5639-7560  
 Fax: 81-3-5639-7507