

LM27951

White LED Adaptive 1.5X/1X Switched Capacitor Current Driver

General Description

The LM27951 is a switched capacitor white-LED driver capable of driving up to 4 LEDs with 30mA through each LED. Its 4 tightly regulated current sources ensure excellent LED current and brightness matching. LED drive current is programmed by an external sense resistor. The LM27951 operates over an input voltage range from 2.8V to 5.5V and requires only four low-cost ceramic capacitors.

The LM27951 provides excellent efficiency without the use of an inductor by operating the charge pump in a gain of 3/2, or in a gain of 1. Maximum efficiency is achieved over the input voltage range by actively selecting the proper gain based on the LED forward voltage requirements.

The LM27951 uses constant frequency pre-regulation to minimize conducted noise on the input. It has a fixed 750kHz switching frequency optimized for portable applications. The LM27951 consumes less than 1 μ A of supply current when shut down.

The LM27951 is available in a 14-pin No-Pullback Leadless Leadframe Package: LLP-14.

Features

- Drives up to 4 LEDs with up to 30mA each
- Regulated current sources with 0.2%(typ.) matching
- 3/2x, 1x Gain transition based on LED V_F
- Peak Efficiency Over 85%
- Input Voltage Range: 2.8V to 5.5V
- PWM Brightness Control
- Very Small Solution Size - NO INDUCTOR
- Fixed 750kHz Switching Frequency
- <1 μ A Shutdown Current
- 14-pin LLP Package: 4.0mm X 3.0mm X 0.8mm

Applications

- White LED Display Backlights
- White LED Keypad Backlights
- General Purpose LED Lighting

Typical Application Circuit

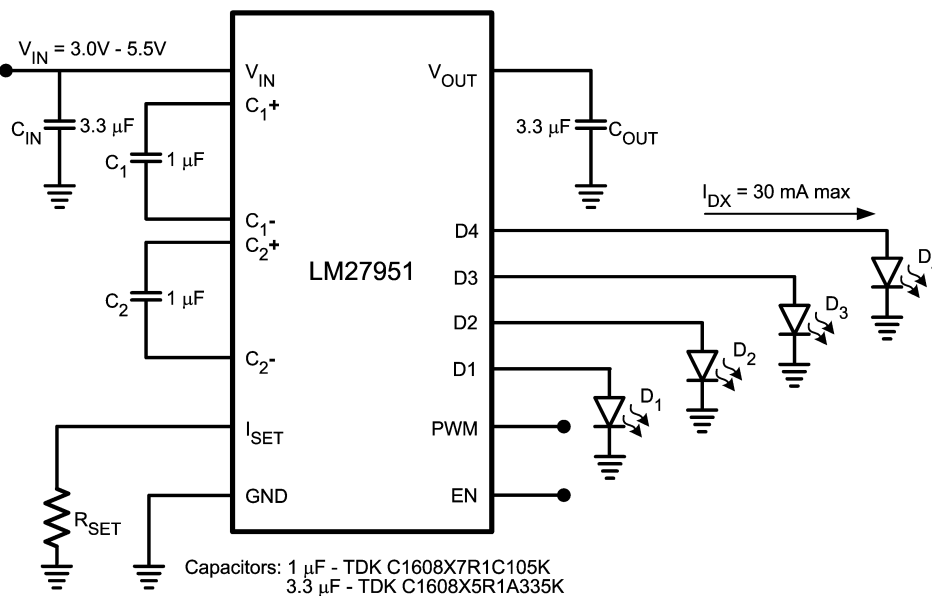

20171701

Connection Diagram

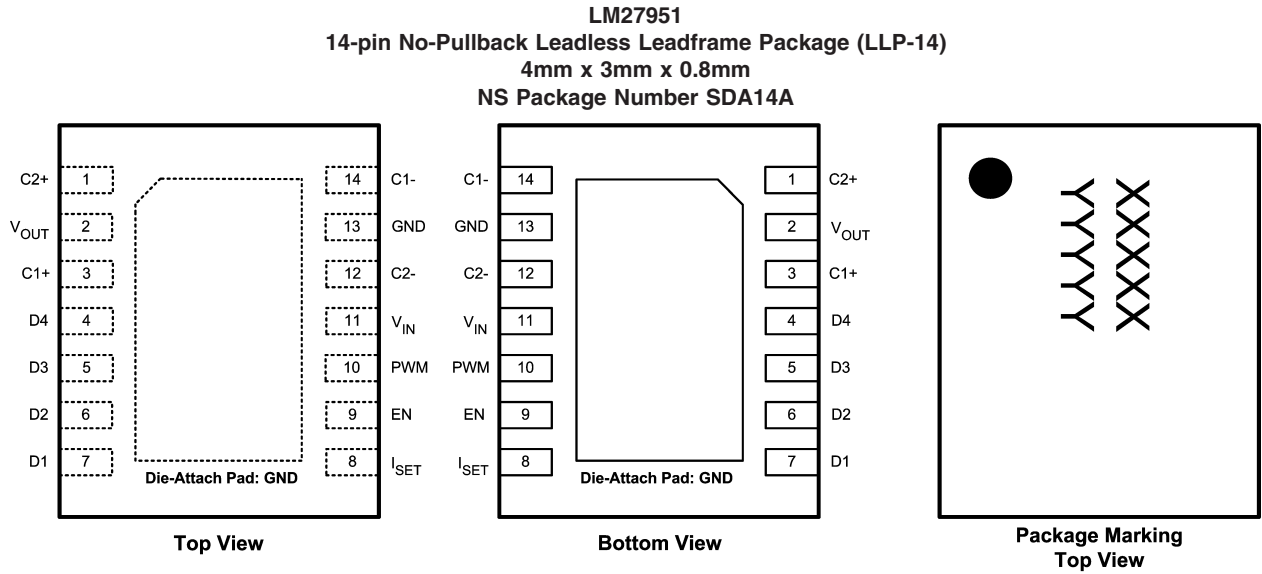

Note: The actual physical placement of the package marking will vary from part to part. The package marking placeholder "XXXXX" is a code for die traceability. "YYYYY" identifies the device (part number, voltage option, etc.). See the Order Information table below for the device ID codes.

20171702

Pin Descriptions

Pin	Name	Description
1	C2+	Flying Capacitor C2 Connection
2	V _{OUT}	Pre-Regulated Charge Pump Output
3	C1+	Flying Capacitor C1 Connection
4	D4	Regulated Current Source Output.
5	D3	Regulated Current Source Output.
6	D2	Regulated Current Source Output.
7	D1	Regulated Current Source Output.
8	I _{SET}	Current Set Input. Placing a resistor (R _{SET}) between this pin and GND sets the LED current for all the LEDs. LED Current = 200 x (1.25V ÷ R _{SET}).
9	EN	Enable Logic Input Pin. Logic Low = Shut Down, Logic High = Enabled. There is a 150kΩ (typ.) resistor connected internally between the EN pin and GND.
10	PWM	Current Source Modulation Logic Input Pin. Logic Low = Off, Logic High = On. Applying a Pulse Width Modulated (PWM) signal to this pin allows the regulated current sources to be modulated without shutting down the internal Charge Pump and the V _{OUT} node.
11	V _{IN}	Input Supply Range: 2.8V to 5.5V.
12	C2-	Flying Capacitor C2 Connection.
13	GND	Power Supply Ground Connection.
14	C1-	Flying Capacitor C1 Connection.

Ordering Information

Order Number	Package Description	Package Marking	Supplied as Tape and Reel (Units)
LM27951SD	No-Pullback	XXXXX = $\epsilon Z \epsilon 2 \epsilon X$	1000
LM27951SDX	LLP-14	YYYYY = D006B	4500

Absolute Maximum Ratings (Notes 1, 2)

If Military/Aerospace specified devices are required, please contact the National Semiconductor Sales Office/Distributors for availability and specifications.

V_{IN}	-0.3V to 6.0V
EN, PWM	-0.3V to ($V_{IN} + 0.3V$) w/ 6.0V max

Continuous Power Dissipation
(Note 3) Internally Limited

Junction Temperature
($T_{J-MAX-ABS}$) 150°C

Storage Temperature Range -65°C to 150°C

Lead Temp. (Soldering, 5 sec.) 260°C

ESD Rating (Note 4)
Human Body Model 2kV

Operating Ratings (Notes 2, 7)

Input Voltage V_{IN}	2.8V to 5.5V
LED Voltage Range	2.5V to 3.9V
Junction Temperature Range (T_J)	-40°C to +115°C
Ambient Temperature Range (T_A) (Note 5)	-40°C to +85°C

Thermal Information

Junction-to-Ambient Thermal Resistance, LLP-14 Package (θ_{JA}) (Note 6)	45°C/W
--	--------

Electrical Characteristics (Notes 2, 7)

Limits in standard typeface are for $T_A = 25^\circ\text{C}$, and limits in **boldface** type apply over the full operating junction temperature range (-40°C to +85°C). Unless otherwise noted, specifications apply to the LM27951 Typical Application Circuit (pg.1) with $V_{IN} = 3.6V$, $V(EN) = 1.8V$, $V(PWM) = 1.8V$, 4 LEDs, $V_{DX} = 3.6V$, $C_{IN} = C_{OUT} = 3.3\mu\text{F}$, $C_1 = C_2 = 1\mu\text{F}$, $R_{SET} = 12.5k\Omega$ (Note 8)

Symbol	Parameter	Conditions	Min	Typ	Max	Units
I_{DX}	LED Current Regulation	$3.0V \leq V_{IN} \leq 5.5V$ $R_{SET} = 12.5k\Omega$ $I_{VOUT} = 0mA$	18.4 (-8%)	20	21.6 (+8%)	mA
		$3.0V \leq V_{IN} \leq 5.5V$ $R_{SET} = 8.32k\Omega$ $I_{VOUT} = 0mA$		30		
		$3.0V \leq V_{IN} \leq 5.5V$ $R_{SET} = 24.9k\Omega$ $I_{VOUT} = 0mA$		10		
$I_{D-MATCH}$	LED Current Matching (Note 9)	$R_{SET} = 8.32k\Omega$		0.2	1.5	%
I_Q	Quiescent Supply Current	$D_{(1-4)} = \text{OPEN}$ $R_{SET} = \text{OPEN}$		1.5	1.9	mA
I_{SD}	Shutdown Supply Current	$3.0V \leq V_{IN} \leq 5.5V$ $V(EN) = 0V$		0.1	1	μA
V_{SET}	I_{SET} Pin Voltage	$3.0V \leq V_{IN} \leq 5.5V$		1.25		V
I_{DX} / I_{SET}	Output Current to Current Set Ratio			200		
V_{HR}	Current Source Voltage Headroom Requirement (Note 10)	$I_{DX} = 95\% I_{DX} (\text{nom.})$ $R_{SET} = 8.32k\Omega$ ($I_{DX} \text{ nom.} = 30mA$)		360		mV
		$I_{DX} = 95\% I_{DX} (\text{nom.})$ $R_{SET} = 12.5k\Omega$ ($I_{DX} \text{ nom.} = 20mA$)		240		
f_{SW}	Switching Frequency		525 (-30%)	750	975 (+30%)	kHz
V_{IH}	Logic Input High	Input Pins: EN, PWM $3.0V \leq V_{IN} \leq 5.5V$	1.0		V_{IN}	V
V_{IL}	Logic Input Low	Input Pins: EN, PWM $3.0V \leq V_{IN} \leq 5.5V$	0		0.4	

Electrical Characteristics (Notes 2, 7) (Continued)

Limits in standard typeface are for $T_A = 25^\circ\text{C}$, and limits in **boldface** type apply over the full operating junction temperature range (-40°C to $+85^\circ\text{C}$). Unless otherwise noted, specifications apply to the LM27951 Typical Application Circuit (pg.1) with $V_{IN} = 3.6\text{V}$, $V(EN) = 1.8\text{V}$, $V(PWM) = 1.8\text{V}$, 4 LEDs, $V_{DX} = 3.6\text{V}$, $C_{IN} = C_{OUT} = 3.3\mu\text{F}$, $C_1 = C_2 = 1\mu\text{F}$, $R_{SET} = 12.5\text{k}\Omega$ (Note 8)

Symbol	Parameter	Conditions	Min	Typ	Max	Units
I_{IH}	Logic Input High Current	Input Pin: PWM $V(PWM) = 1.8\text{V}$		10		nA
		Input Pin: EN $V(EN) = 1.8\text{V}$ (Note 11)		12		μA
I_{IL}	Logic Input Low Current	Input Pins: EN, PWM $V(EN, PWM) = 0\text{V}$		10		nA
R_{OUT}	Charge Pump Output Resistance (Note 12)			3.3		Ω
V_{GDX}	1x to 3/2x Gain Transition Voltage Threshold on V_{DX}	$(V_{OUT} - V_{DX})$ Falling		500		mV
t_{ON}	Startup Time	$I_{DX} = 90\%$ steady state		330		μs

Note 1: Absolute Maximum Ratings indicate limits beyond which damage to the component may occur. Operating Ratings are conditions under which operation of the device is guaranteed. Operating Ratings do not imply guaranteed performance limits. For guaranteed performance limits and associated test conditions, see the Electrical Characteristics tables.

Note 2: All voltages are with respect to the potential at the GND pin.

Note 3: Internal thermal shutdown circuitry protects the device from permanent damage. Thermal shutdown engages at $T_J = 150^\circ\text{C}$ (typ.) and disengages at $T_J = 140^\circ\text{C}$ (typ.).

Note 4: The Human-body model is a 100 pF capacitor discharged through a 1.5k Ω resistor into each pin.

Note 5: In applications where high power dissipation and/or poor package thermal resistance is present, the maximum ambient temperature may have to be derated. Maximum ambient temperature (T_{A-MAX}) is dependent on the maximum operation junction temperature ($T_{J-MAX-OP} = 115^\circ\text{C}$), the maximum power dissipation of the device in the application (P_{D-MAX}), and the junction-to ambient thermal resistance of the part/package in the application (θ_{JA}), as given by the following equation: $T_{A-MAX} = T_{J-MAX-OP} - (\theta_{JA} \times P_{D-MAX})$.

Note 6: Junction-to-ambient thermal resistance (θ_{JA}) is taken from a thermal modeling result, performed under the conditions and guidelines set forth in the JEDEC standard JESD51-7. The test board is a 4 layer FR-4 board measuring 102mm x 76mm x 1.6mm with a 2 x 1 array of thermal vias. The ground plane on the board is 50mm x 50mm. Thickness of copper layers are 36 $\mu\text{m}/18\mu\text{m}/18\mu\text{m}/36\mu\text{m}$ (1.5oz/1oz/1oz/1.5oz). Ambient temperature in simulation is 22 $^\circ\text{C}$, still air. Power dissipation is 1W.

The value of θ_{JA} of the LM27951 in LLP-14 could fall in a range as wide as 45 $^\circ\text{C}/\text{W}$ to 150 $^\circ\text{C}/\text{W}$ (if not wider), depending on PWB material, layout, and environmental conditions. In applications where high maximum power dissipation exists (high V_{IN} , high I_{OUT}), special care must be paid to thermal dissipation issues. For more information on these topics, please refer to **Application Note 1187: Leadless Leadframe Package (LLP)** and the **Power Efficiency and Power Dissipation** section of this datasheet.

Note 7: Min and Max limits are guaranteed by design, test, or statistical analysis. Typical numbers are not guaranteed, but do represent the most likely norm.

Note 8: C_{IN} , C_{OUT} , C_1 , C_2 : Low-ESR Surface-Mount Ceramic Capacitors (MLCCs) used in setting electrical characteristics

Note 9: LED Current Matching is based on two calculations: $[(I_{MAX} - I_{AVG}) \div I_{AVG}]$ and $[(I_{AVG} - I_{MIN}) \div I_{AVG}]$. I_{MAX} and I_{MIN} are the highest and lowest respective Dx currents, and I_{AVG} is the average Dx current of all four current sources. The largest number of the two calculations (worst case) is considered the matching figure for the part. The typical specification provided is the most likely norm of the matching figure for all parts.

Note 10: Headroom Voltage (V_{HR}) = $V_{OUT} - V_{DX}$. If headroom voltage requirement is not met, LED current regulation will be compromised.

Note 11: EN Logic Input High Current (I_{IH}) is due to a 150k Ω (typ.) pull-down resistor connected internally between the EN and GND pins.

Note 12: The open loop output resistance (R_{OUT}) models all voltage losses in the charge pump. R_{OUT} can be used to estimate the voltage at the charge pump output V_{OUT} and the maximum current capability of the device under low V_{IN} and high I_{OUT} conditions, beyond what is specified in the electrical specifications table: $V_{OUT} = (G \times V_{IN}) - (R_{OUT} \times I_{OUT})$. In the equation, G is the charge pump gain mode, and I_{OUT} is the total output current (sum of all active Dx current sources and all current drawn from V_{OUT}).

Note 13: Turn-on time is measured from when the EN signal is pulled high until the output voltage on V_{OUT} crosses 90% of its final value.

Block Diagram

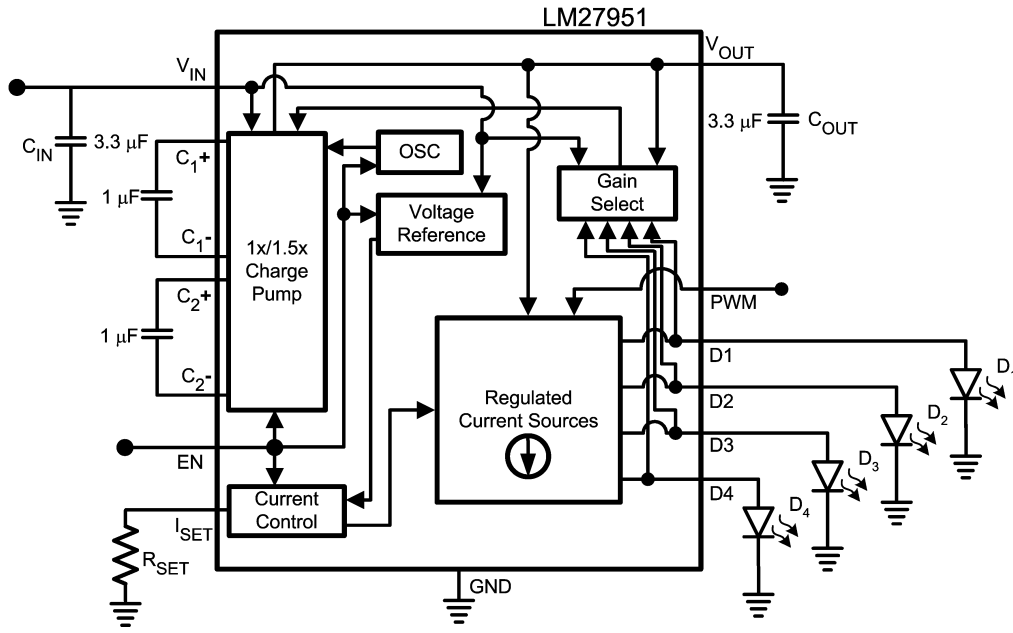

20171703

Typical Performance Characteristics Unless otherwise specified: $T_A = 25^\circ\text{C}$, 4 LEDs, $V_{DX} = 3.6\text{V}$, $V_{IN} = 3.6\text{V}$, $V_{EN} = V_{IN}$, $V_{PWM} = V_{IN}$, $C_1 = C_2 = 1\mu\text{F}$, $C_{IN} = C_{OUT} = 3.3\mu\text{F}$. Capacitors are low-ESR multi-layer ceramic capacitors (MLCC's).

LED Current Regulation vs. Input Voltage

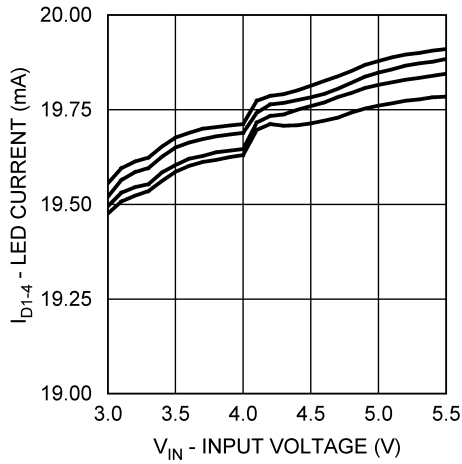

20171704

Average LED Current Regulation vs. Input Voltage

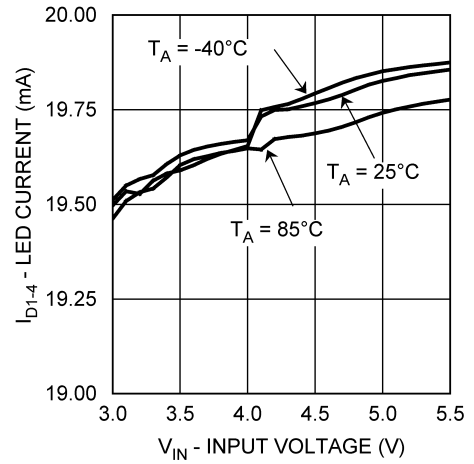

20171706

Converter Efficiency vs. Input Voltage

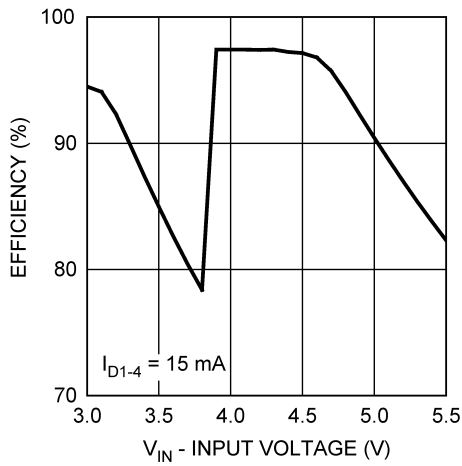

20171708

LED Current vs. R_{SET}

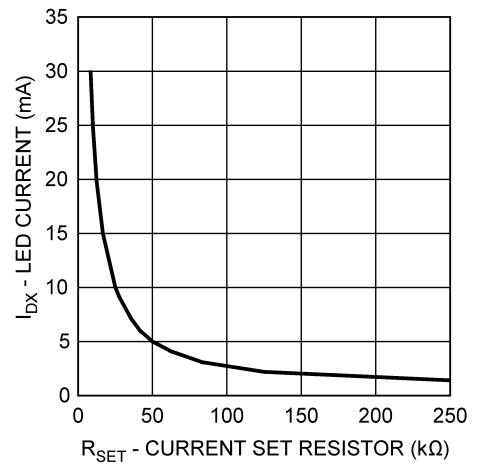

20171709

Input and Output Voltage Ripple

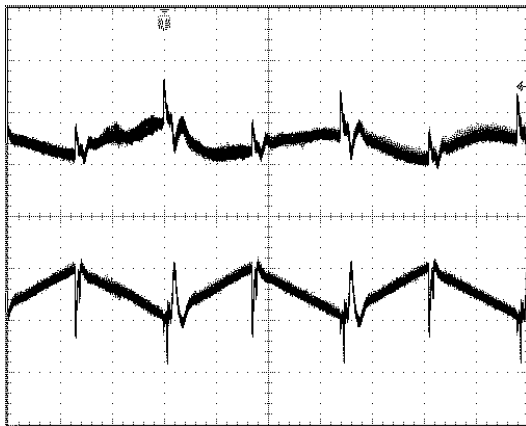

20171712

$V_{IN} = 3.6\text{V}$, Load = 15mA/LED, 4 LEDs
 CH1 (TOP): V_{IN} ; Scale: 20mV/Div, AC Coupled
 CH2 (BOTTOM): V_{OUT} ; Scale: 20mV/Div, AC Coupled
 Time scale: 400ns/Div

Startup Response

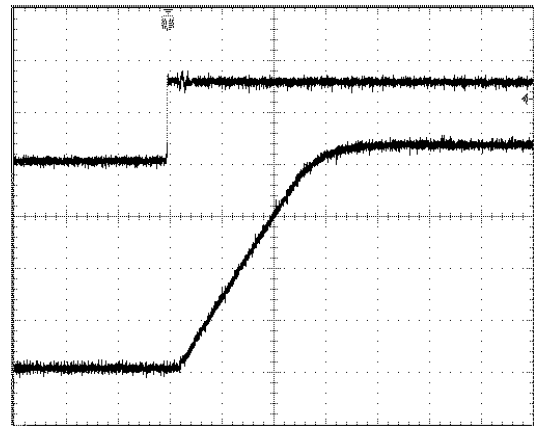

20171713

$V_{IN} = 3.6\text{V}$, Load = 20mA/LED, 4 LEDs
 CH1 (TOP): V_{EN} ; Scale: 1V/Div
 CH2 (BOTTOM): V_{OUT} ; Scale: 1V/Div
 Time scale: 100μs/Div

Application Information

CIRCUIT DESCRIPTION

The LM27951 is an adaptive 1.5x/1x CMOS charge pump, optimized for driving white LEDs used in small-format display backlighting. It provides four constant current outputs capable of sourcing up to 30mA through each LED. The well-matched current sources ensure the current through all the LEDs are virtually identical, providing a uniform brightness across the entire display.

Each current source is internally connected to the charge pump output, V_{OUT} . LED drive current is programmed by connecting a resistor, R_{SET} , to the current set pin, I_{SET} . LED brightness is adjusted by applying a Pulse Width Modulated (PWM) signal to the dedicated PWM input pin.

CHARGE PUMP

The input to the 1.5x/1x charge pump is connected to the V_{IN} pin, and the loosely regulated output of the charge pump is connected to the V_{OUT} pin. The recommended input voltage range of the LM27951 is 3.0V to 5.5V. The device's loosely-regulated charge pump has both open loop and closed loop modes of operation. When the device is in open loop, the voltage at V_{OUT} is equal to the gain times the voltage at the input. When the device is in closed loop, the voltage at V_{OUT} is loosely regulated to 4.5V (typ.). The charge pump gain transitions are actively selected to maintain regulation based on LED forward voltage and load requirements. This allows the charge pump to stay in the most efficient gain (1x) over as much of the input voltage range as possible, reducing the power consumed from the battery.

SOFT START

The LM27951 contains internal soft-start circuitry to limit input inrush currents when the part is enabled. Soft start is implemented internally with a controlled turn-on of the internal voltage reference. Due to the soft-start circuitry, startup time of the LM27951 is approximately 330 μ s (typ.).

ENABLE AND PWM PINS

The LM27951 has 2 logic control pins. Both pins are active-high logic (HIGH = ON). There is an internal pull-down resistor (150k Ω typ.) connected between the enable pin (EN) and GND. There is no pull-up or pull-down connected to the Pulse Width Modulated (PWM) pin.

The EN pin is the master enable pin for the part. When the voltage on this pin is low (<0.4V), the part is in shutdown mode. In this mode, all internal circuitry is OFF and the part consumes very little supply current (<1 μ A typ.). When the voltage on the EN pin is high (>1.0V), the part will activate the charge pump and regulate the output voltage to its nominal value.

The PWM pin serves as a dedicated logic input for LED brightness control. When the voltage on this pin is low (<0.4V), the current sources will be turned off and no current will flow through the LEDs. When the voltage on this pin is high (>1.0V), the current sources will turn on and regulate to the current level set by the resistor connected to the I_{SET} pin.

SETTING LED CURRENTS

The current through the four LEDs connected to D_{1-4} can be set to a desired level simply by connecting an appropriately sized resistor (R_{SET}) between the I_{SET} pin of the LM27951 and GND. The LED currents are proportional to the current

that flows out of the I_{SET} pin and are a factor of 200 times greater than the I_{SET} current. The feedback loop of an internal amplifier sets the voltage of the I_{SET} pin to 1.25V (typ.). The statements above are simplified in the equations below:

$$I_{Dx} = 200 \times (V_{SET} / R_{SET})$$

$$R_{SET} = 200 \times (1.25V / I_{Dx})$$

ADJUSTING LED BRIGHTNESS (PWM control)

Perceived LED brightness can be adjusted using a PWM control signal on the LM27951 PWM logic input pin, turning the current sources ON and OFF at a rate faster than perceptible by the human eye. When this is done, the total brightness perceived is proportional to the duty cycle (D) of the PWM signal (D = the percentage of time that the LED is on in every PWM cycle). A simple example: if the LEDs are driven at 15mA each with a PWM signal that has a 50% duty cycle, perceived LED brightness will be about half as bright as compared to when the LEDs are driven continuously with 15mA.

The minimum recommended PWM frequency is 100Hz. Frequencies below this may be visible as flicker or blinking. The maximum recommended PWM frequency is 1kHz. Frequencies above this may cause interference with internal current driver circuitry and/or noise in the audible range. Due to the regulation control loop, the maximum frequency and minimum duty cycle applied to the PWM pin should be chosen such that the minimum ON time is no less than 30 μ s in duration. If a PWM signal is applied to the EN pin instead, the maximum frequency and minimum duty cycle should be chosen to accommodate both the LM27951 startup time (330 μ s typ.) and the 30 μ s control loop delay.

The preferred method to adjust brightness is to keep the master EN voltage ON continuously and apply a PWM signal to the dedicated PWM input pin. The benefit of this type of connection can be best understood with a contrary example. When a PWM signal is connected to the master enable (EN) pin, the charge pump repeatedly turns on and off. Every time the charge pump turns on, there is an inrush of current as the capacitors, both internal and external, are recharged. This inrush current results in a current spike and a voltage dip at the input of the part. By applying the PWM signal to PWM logic input pin, the charge pump remains active, resulting in much lower input noise.

In cases where a PWM signal must be connected to the EN pin, measures can be taken to reduce the magnitude of the charge-pump turn-on transient response. More input capacitance, series resistors and/or ferrite beads may provide benefits. If the current spikes and voltage dips can be tolerated, connecting the PWM signal to the EN pin does provide a benefit of lower supply current consumption. When the PWM signal to the EN pin is low, the LM27951 will be shutdown and input current will only be a few micro-amps. This results in a lower time-averaged input current than the prior suggestion, where EN is kept on continuously.

MAXIMUM OUTPUT CURRENT, MAXIMUM LED VOLTAGE, MINIMUM INPUT VOLTAGE

The LM27951 can drive 4 LEDs at 30mA each from an input voltage as low as 3.0V, so long as the LEDs have a forward voltage of 3.6V or less (room temperature).

The statement above is a simple example of the LED drive capabilities of the LM27951. The statement contains key application parameters required to validate an LED-drive

Application Information (Continued)

design using the LM27951: LED current (I_{LED}), number of active LEDs (N), LED forward voltage (V_{LED}), and minimum input voltage (V_{IN-MIN}).

The equation below can be used to estimate the total output current capability of the LM27951:

$$I_{LED_MAX} = ((1.5 \times V_{IN}) - V_{LED}) / ((N \times R_{OUT}) + k_{HR}) \quad (\text{eq. 1})$$

$$I_{LED_MAX} = ((1.5 \times V_{IN}) - V_{LED}) / ((N \times 3.3\Omega) + 12\text{mV/mA})$$

R_{OUT} – Output resistance. This parameter models the internal losses of the charge pump that result in voltage droop at the pump output V_{OUT} . Since the magnitude of the voltage droop is proportional to the total output current of the charge pump, the loss parameter is modeled as a resistance. The output resistance of the LM27951 is typically 3.3Ω ($V_{IN} = 3.0\text{V}$, $T_A = 25^\circ\text{C}$). In equation form:

$$V_{OUT} = 1.5 \times V_{IN} - N \times I_{LED} \times R_{OUT} \quad (\text{eq. 2})$$

k_{HR} – Headroom constant. This parameter models the minimum voltage required across the current sources for proper regulation. This minimum voltage is proportional to the programmed LED current, so the constant has units of mV/mA. The typical k_{HR} of the LM27951 is 12mV/mA. In equation form:

$$(V_{OUT} - V_{LED}) > k_{HR} \times I_{LED} \quad (\text{eq. 3})$$

The " I_{LED_MAX} " equation (eq. 1) is obtained from combining the R_{OUT} equation (eq. 2) with the k_{HR} equation (eq. 3) and solving for I_{LED} . Maximum LED current is highly dependent on minimum input voltage and LED forward voltage. Output current capability can be increased by raising the minimum input voltage of the application, or by selecting LEDs with a lower forward voltage. Excessive power dissipation may also limit output current capability of an application.

CAPACITOR SELECTION

The LM27951 requires 4 external capacitors for proper operation. Surface-mount multi-layer ceramic capacitors are recommended. These capacitors are small, inexpensive and have very low equivalent series resistance (ESR <20m Ω typ.). Tantalum capacitors, OS-CON capacitors, and aluminum electrolytic capacitors are not recommended for use with the LM27951 due to their high ESR, as compared to ceramic capacitors.

For most applications, ceramic capacitors with X7R or X5R temperature characteristic are preferred for use with the LM27951. These capacitors have tight capacitance tolerance (as good as $\pm 10\%$) and hold their value over temperature (X7R: $\pm 15\%$ over -55°C to 125°C ; X5R: $\pm 15\%$ over -55°C to 85°C).

Capacitors with Y5V or Z5U temperature characteristic are generally not recommended for use with the LM27951. Capacitors with these temperature characteristics typically have wide capacitance tolerance (+80%, -20%) and vary significantly over temperature (Y5V: +22%, -82% over -30°C to $+85^\circ\text{C}$ range; Z5U: +22%, -56% over $+10^\circ\text{C}$ to $+85^\circ\text{C}$ range). Under some conditions, a nominal 1 μF Y5V or Z5U capacitor could have a capacitance of only 0.1 μF . Such detrimental deviation is likely to cause Y5V and Z5U capacitors to fail to meet the minimum capacitance requirements of the LM27951.

The voltage rating of the output capacitor should be 10V or more. All other capacitors should have a voltage rating at or above the maximum input voltage of the application.

PARALLEL DX OUTPUTS FOR INCREASED CURRENT DRIVE

Outputs D_{1-4} may be connected together to drive a one or two LEDs at higher currents. In a one LED configuration, all four parallel current sources of equal value are connected together to drive a single LED. The LED current programmed should be chosen such that the current provided from each of the outputs is programmed to 25% of the total desired LED current. For example, if 60mA is the desired drive current for the single LED, R_{SET} should be selected such that the current out of each current source is 15mA. Similarly, if two LEDs are to be driven by pairing up the D_{1-4} outputs (i.e. D_{1-2} , D_{3-4}), R_{SET} should be selected such that the current out of each current source output is 50% of the desired LED current.

Connecting the outputs in parallel does not affect the internal operation of the LM27951 and has no impact on the Electrical Characteristics and limits previously presented. The available diode output current, maximum diode voltage, and all other specifications provided in the Electrical Characteristics table apply to this parallel output configuration, just as they do to the standard 4-LED application circuit.

POWER EFFICIENCY

Efficiency of LED drivers is commonly taken to be the ratio of power consumed by the LEDs (P_{LED}) to the power drawn at the input of the part (P_{IN}). With a 1.5x/1x charge pump, the input current is equal to the charge pump gain times the output current (total LED current). For a simple approximation, the current consumed by internal circuitry can be neglected and the efficiency of the LM27951 can be predicted as follows:

$$P_{LED} = N \times V_{LED} \times I_{LED}$$

$$P_{IN} = V_{IN} \times I_{IN}$$

$$P_{IN} = V_{IN} \times (\text{Gain} \times N \times I_{LED} + I_Q)$$

$$E = (P_{LED} \div P_{IN})$$

Neglecting I_Q will result in a slightly higher efficiency prediction, but this impact will be no more than a few percentage points when several LEDs are driven at full power. It is also worth noting that efficiency as defined here is in part dependent on LED voltage. Variation in LED voltage does not affect power consumed by the circuit and typically does not relate to the brightness of the LED. For an advanced analysis, it is recommended that power consumed by the circuit ($V_{IN} \times I_{IN}$) be evaluated rather than power efficiency.

THERMAL PROTECTION

Internal thermal protection circuitry disables the LM27951 when the junction temperature exceeds 150°C (typ.). This feature protects the device from being damaged by high die temperatures that might otherwise result from excessive power dissipation. The device will recover and operate normally when the junction temperature falls below 140°C (typ.). It is important that the board layout provide good thermal conduction to keep the junction temperature within the specified operating ratings.

POWER DISSIPATION

The power dissipation ($P_{DISSIPATION}$) and junction temperature (T_J) can be approximated with the equations below. P_{IN} is the power generated by the 1.5x/1x charge pump, P_{LED} is the power consumed by the LEDs, T_A is the ambient temperature, and θ_{JA} is the junction-to-ambient thermal resis-

Application Information (Continued)

tance for the LLP-14 package. V_{IN} is the input voltage to the LM27951, V_{LED} is the nominal LED forward voltage, and I_{LED} is the programmed LED current.

$$P_{DISSIPATION} = P_{IN} - P_{LED}$$

$$= [\text{Gain} \times V_{IN} \times (4 \times I_{LED})] - (V_{LED} \times 4 \times I_{LED})$$

$$T_J = T_A + (P_{DISSIPATION} \times \theta_{JA})$$

The junction temperature rating takes precedence over the ambient temperature rating. The LM27951 may be operated outside the ambient temperature rating, so long as the junction temperature of the device does not exceed the maximum operating rating of 115°C. The maximum ambient temperature rating must be derated in applications where high power dissipation and/or poor thermal resistance causes the junction temperature to exceed 115°C.

PCB Layout Considerations

The LLP is a leadframe based Chip Scale Package (CSP) with very good thermal properties. This package has an exposed DAP (die attach pad) at the center of the package measuring 3.0mm x 1.6mm. The main advantage of this exposed DAP is to offer lower thermal resistance when it is soldered to the thermal land on the PCB. For PCB layout, National highly recommends a 1:1 ratio between the package and the PCB thermal land. To further enhance thermal conductivity, the PCB thermal land may include vias to a ground plane. For more detailed instructions on mounting LLP packages, please refer to National Semiconductor Application Note AN-1187.

Physical Dimensions inches (millimeters) unless otherwise noted

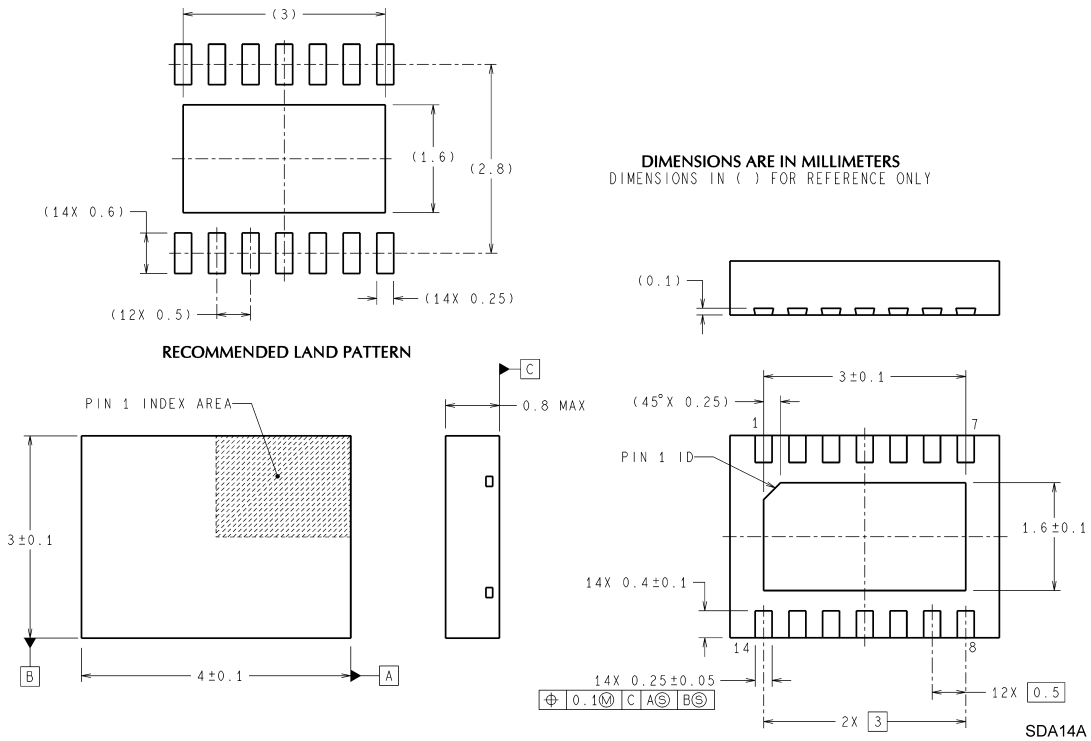

National does not assume any responsibility for use of any circuitry described, no circuit patent licenses are implied and National reserves the right at any time without notice to change said circuitry and specifications.

For the most current product information visit us at www.national.com.

LIFE SUPPORT POLICY

NATIONAL'S PRODUCTS ARE NOT AUTHORIZED FOR USE AS CRITICAL COMPONENTS IN LIFE SUPPORT DEVICES OR SYSTEMS WITHOUT THE EXPRESS WRITTEN APPROVAL OF THE PRESIDENT AND GENERAL COUNSEL OF NATIONAL SEMICONDUCTOR CORPORATION. As used herein:

1. Life support devices or systems are devices or systems which, (a) are intended for surgical implant into the body, or (b) support or sustain life, and whose failure to perform when properly used in accordance with instructions for use provided in the labeling, can be reasonably expected to result in a significant injury to the user.
2. A critical component is any component of a life support device or system whose failure to perform can be reasonably expected to cause the failure of the life support device or system, or to affect its safety or effectiveness.

BANNED SUBSTANCE COMPLIANCE

National Semiconductor manufactures products and uses packing materials that meet the provisions of the Customer Products Stewardship Specification (CSP-9-111C2) and the Banned Substances and Materials of Interest Specification (CSP-9-111S2) and contain no "Banned Substances" as defined in CSP-9-111S2.

Leadfree products are RoHS compliant.



National Semiconductor
Americas Customer
Support Center
Email: new.feedback@nsc.com
Tel: 1-800-272-9959

National Semiconductor
Europe Customer Support Center
Fax: +49 (0) 180-530 85 86
Email: europe.support@nsc.com
Deutsch Tel: +49 (0) 69 9508 6208
English Tel: +44 (0) 870 24 0 2171
Français Tel: +33 (0) 1 41 91 8790

National Semiconductor
Asia Pacific Customer
Support Center
Email: ap.support@nsc.com

National Semiconductor
Japan Customer Support Center
Fax: 81-3-5639-7507
Email: jpn.feedback@nsc.com
Tel: 81-3-5639-7560