



October 2003

# LM5110

## Dual 5A Compound Gate Driver with Negative Output Voltage Capability

### General Description

The LM5110 Dual Gate Driver replaces industry standard gate drivers with improved peak output current and efficiency. Each “compound” output driver stage includes MOS and bipolar transistors operating in parallel that together sink more than 5A peak from capacitive loads. Combining the unique characteristics of MOS and bipolar devices reduces drive current variation with voltage and temperature. Separate input and output ground pins provide Negative Drive Capability allowing the user to drive MOSFET gates with positive and negative VGS voltages. The gate driver control inputs are referenced to a dedicated input ground (IN\_REF). The gate driver outputs swing from V<sub>CC</sub> to the output ground V<sub>EE</sub> which can be negative with respect to IN\_REF. The ability to hold MOSFET gates off with a negative VGS voltage reduces losses when driving low threshold voltage MOSFETs often used as synchronous rectifiers. When driving with conventional positive only gate voltage, the IN\_REF and V<sub>EE</sub> pins are connected together and referenced to a common ground. Under-voltage lockout protection and a shutdown input pin are also provided. The drivers can be operated in parallel with inputs and outputs connected to double the drive current capability. This device is available in the SOIC-8 and the thermally-enhanced LLP-10 packages.

### Features

- Independently drives two N-Channel MOSFETs
- Compound CMOS and bipolar outputs reduce output current variation

- 5A sink/3A source current capability
- Two channels can be connected in parallel to double the drive current
- Independent inputs (TTL compatible)
- Fast propagation times (25 ns typical)
- Fast rise and fall times (14 ns/12 ns rise/fall with 2 nF load)
- Dedicated input ground pin (IN\_REF) for split supply or single supply operation
- Outputs swing from V<sub>CC</sub> to V<sub>EE</sub> which can be negative relative to input ground
- Available in dual non-inverting, dual inverting and combination configurations
- Shutdown input provides low power mode
- Supply rail under-voltage lockout protection
- Pin-out compatible with industry standard gate drivers

### Typical Applications

- Synchronous Rectifier Gate Drivers
- Switch-mode Power Supply Gate Driver
- Solenoid and Motor Drivers
- Power Level Shifter

### Package

- SOIC-8
- LLP-10 (4 mm x 4 mm)

### Ordering Information

Order Number	Package Type	NSC Package Drawing	Supplied As
LM5110-1/2/3 M	SOIC-8	M08A	Shipped in anti-static units
LM5110-1/2/3 MX	SOIC-8	M08A	2500 shipped in Tape & Reel
LM5110-1/2/3 SD	LLP-10	SDC10A	1000 shipped in Tape & Reel
LM5110-1/2/3 SDX	LLP-10	SDC10A	4500 shipped in Tape & Reel

LM5110 Dual 5A Compound Gate Driver with Negative Output Voltage Capability



### Pin Configurations

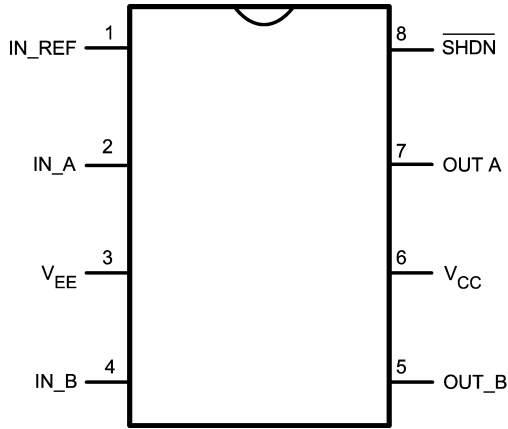

SOIC-8

20079201

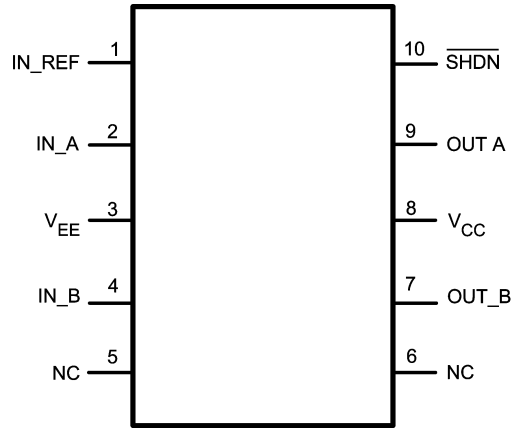

LLP-10  
NC - NOT CONNECTED

20079202

### Block Diagram

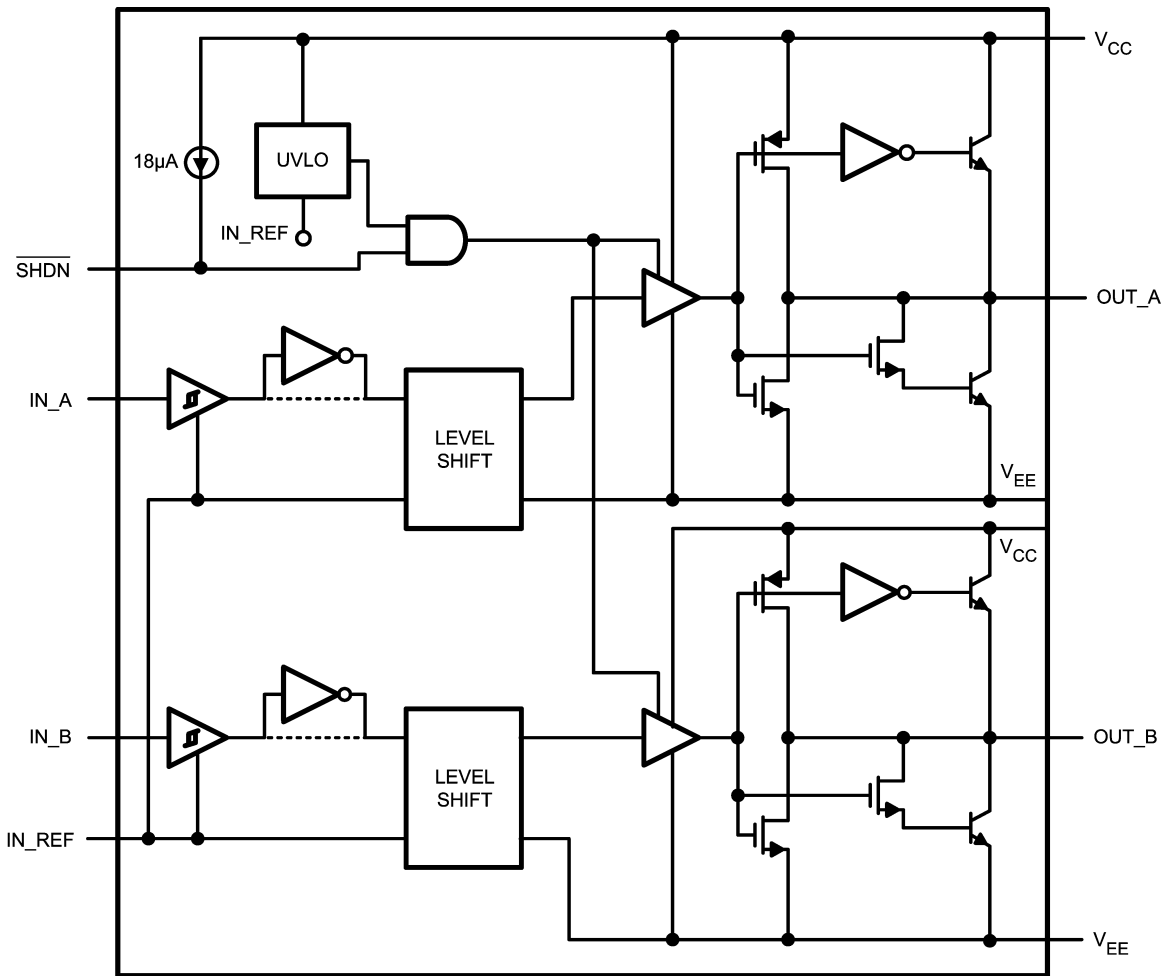

Block Diagram of LM5110

20079203

# Typical Application

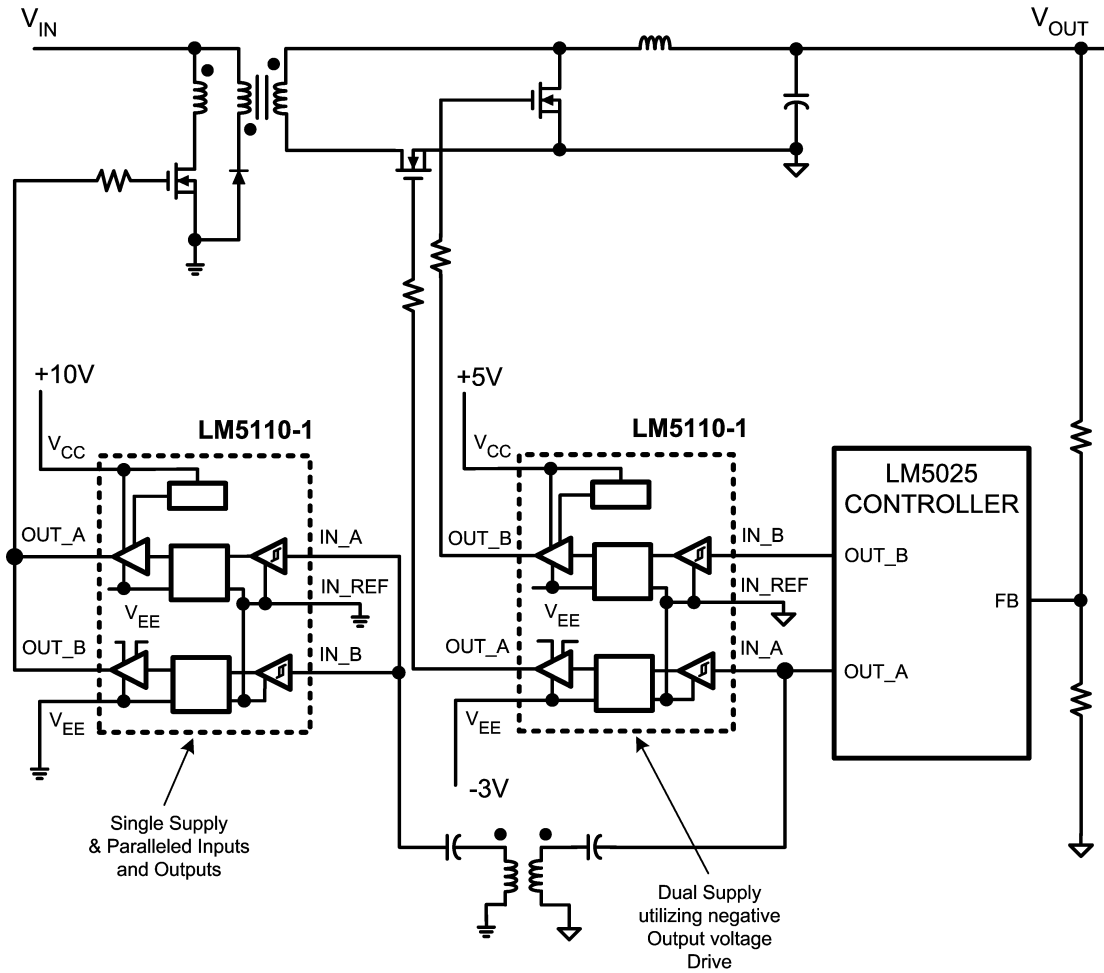

Simplified Power Converter Using Synchronous Rectifiers with Negative Off Gate Voltage

20079204

## Pin Description

Pin Description		Name	Description	Application Information
SOIC-8	LLP-10			
1	1	IN_REF	Ground reference for control inputs	Connect to $V_{EE}$ for standard positive only output voltage swing. Connect to system logic ground reference for positive and negative output voltage swing.
2	2	IN_A	'A' side control input	TTL compatible thresholds.
3	3	$V_{EE}$	Power ground of the driver outputs	Connect to either power ground or a negative gate drive supply.
4	4	IN_B	'B' side control input	TTL compatible thresholds.
5	7	OUT_B	Output for the 'B' side driver.	Capable of sourcing 3A and sinking 5A. Voltage swing of this output is from $V_{CC}$ to $V_{EE}$ .
6	8	$V_{CC}$	Positive supply	Locally decouple to $V_{EE}$ and IN_REF.
7	9	OUT_A.	Output for the 'A' side driver.	Capable of sourcing 3A and sinking 5A. Voltage swing of this output is from $V_{CC}$ to $V_{EE}$ .
8	10	nSHDN	Shutdown input pin	Pull below 1.5V to activate low power shutdown mode.

**Note:** Pins 5 and 6 are No Connect for LLP-10 package.

## Configuration Table

Part Number	"A" Output Configuration	"B" Output Configuration	Package
LM5110-1M	Non-Inverting	Non-Inverting	SOIC- 8
LM5110-2M	Inverting	Inverting	SOIC- 8
LM5110-3M	Inverting	Non-Inverting	SOIC- 8
LM5110-1SD	Non-Inverting	Non-Inverting	LLP-10
LM5110-2SD	Inverting	Inverting	LLP-10
LM5110-3SD	Inverting	Non-Inverting	LLP-10

### Absolute Maximum Ratings (Note 1)

If Military/Aerospace specified devices are required, please contact the National Semiconductor Sales Office/Distributors for availability and specifications.

$V_{CC}$ to $V_{EE}$	-0.3V to 15V	$IN\_REF$ to $V_{EE}$	-0.3V to 5V
$V_{CC}$ to $IN\_REF$	-0.3V to 15V	Storage Temperature Range, ( $T_{STG}$ )	-55°C to +150°C
$IN$ to $IN\_REF$ , $nSHDN$ to $IN\_REF$	-0.3V to 15V	Maximum Junction Temperature, ( $T_J(max)$ )	+150°C
		Operating Junction Temperature	+125°C
		ESD Rating	2kV

### Electrical Characteristics

$T_J = -40^\circ\text{C}$  to  $+125^\circ\text{C}$ ,  $V_{CC} = 12\text{V}$ ,  $V_{EE} = IN\_REF = 0\text{V}$ ,  $nSHDN = V_{CC}$ , No Load on  $OUT\_A$  or  $OUT\_B$ , unless otherwise specified.

Symbol	Parameter	Conditions	Min	Typ	Max	Units
	$V_{CC}$ Operating Range	$V_{CC}-IN\_REF$ and $V_{CC}-V_{EE}$	3.5		14	V
$V_{CCR}$	$V_{CC}$ Under Voltage Lockout (rising)	$V_{CC}-IN\_REF$	2.3	2.9	3.5	V
$V_{CCH}$	$V_{CC}$ Under Voltage Lockout Hysteresis			230		mV
$I_{CC}$	$V_{CC}$ Supply Current ( $I_{CC}$ )	$IN\_A = IN\_B = 0\text{V}$ (5110-1)		1	2	mA
		$IN\_A = IN\_B = V_{CC}$ (5110-2)		1	2	
		$IN\_A = V_{CC}$ , $IN\_B = 0\text{V}$ (5110-3)		1	2	
$I_{CCSD}$	$V_{CC}$ Shutdown Current ( $I_{CC}$ )	$nSHDN = 0\text{V}$		18	25	$\mu\text{A}$

#### CONTROL INPUTS

$V_{IH}$	Logic High			1.75	2.2	V
$V_{IL}$	Logic Low		0.8	1.35		V
HYS	Input Hysteresis			400		mV
$I_{IL}$	Input Current Low	$IN\_A=IN\_B=V_{CC}$ (5110-1-2-3)	-1	0.1	1	$\mu\text{A}$
		$IN\_A=IN\_B=V_{CC}$ (5110-1)	10	18	25	
$I_{IH}$	Input Current High	$IN\_A=IN\_B=V_{CC}$ (5110-2)	-1	0.1	1	
		$IN\_A=V_{CC}$ (5110-3)	-1	0.1	1	
		$IN\_B=V_{CC}$ (5110-3)	10	18	25	

#### SHUTDOWN INPUT

ISD	Pull-up Current	$nSHDN = 0\text{V}$		-18	-25	$\mu\text{A}$
VSDR	Shutdown Threshold	$nSHDN$ rising	0.8	1.5	2.2	V
VSDH	Shutdown Hysteresis			165		mV

#### OUTPUT DRIVERS

$R_{OH}$	Output Resistance High	$I_{OUT} = -10\text{mA}$		30	50	$\Omega$
$R_{OL}$	Output Resistance Low	$I_{OUT} = +10\text{mA}$		1.4	2.5	$\Omega$
$I_{Source}$	Peak Source Current	$OUTA/OUTB = V_{CC}/2$ , 200 ns Pulsed Current		3		A
$I_{Sink}$	Peak Sink Current	$OUTA/OUTB = V_{CC}/2$ , 200 ns Pulsed Current		5		A

## Electrical Characteristics (Continued)

$T_J = -40^\circ\text{C}$  to  $+125^\circ\text{C}$ ,  $V_{CC} = 12\text{V}$ ,  $V_{EE} = \text{IN\_REF} = 0\text{V}$ ,  $\text{nSHDN} = V_{CC}$ , No Load on OUT\_A or OUT\_B, unless otherwise specified.

Symbol	Parameter	Conditions	Min	Typ	Max	Units
<b>SWITCHING CHARACTERISTICS</b>						
$t_{d1}$	Propagation Delay Time Low to High, IN rising (IN to OUT)	$C_{\text{LOAD}} = 2\text{ nF}$ , see <i>Figure 1</i>		25	40	ns
$t_{d2}$	Propagation Delay Time High to Low, IN falling (IN to OUT)	$C_{\text{LOAD}} = 2\text{ nF}$ , see <i>Figure 1</i>		25	40	ns
$t_r$	Rise Time	$C_{\text{LOAD}} = 2.0\text{ nF}$ , see <i>Figure 1</i>		14	25	ns
$t_f$	Fall Time	$C_{\text{LOAD}} = 2\text{ nF}$ , see <i>Figure 1</i>		12	25	ns
<b>LATCHUP PROTECTION</b>						
	AEC - Q100, Method 004	$T_J = 150^\circ\text{C}$		500		mA

**Note 1:** Absolute Maximum Ratings are limits beyond which damage to the device may occur. Operating Ratings are conditions under which operation of the device is intended to be functional. For guaranteed specifications and test conditions, see the Electrical Characteristics.

## Timing Waveforms

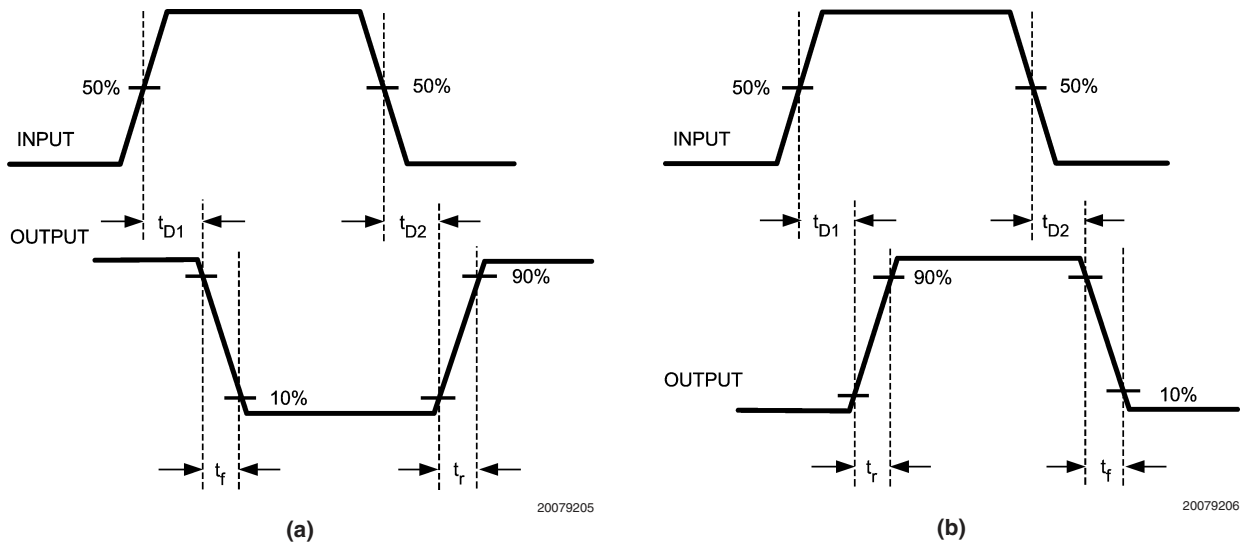
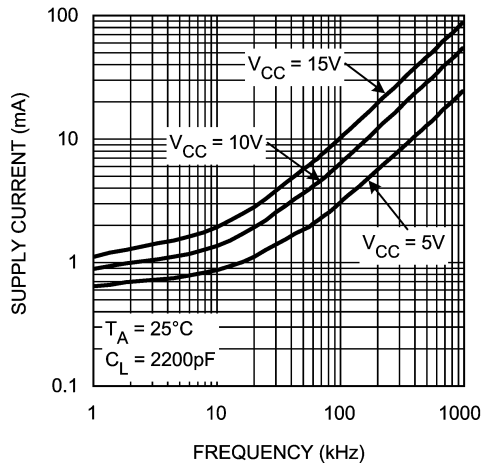

FIGURE 1. (a) Inverting, (b) Non-Inverting

# Typical Performance Characteristics

Supply Current vs Frequency



20079210

Supply Current vs Capacitive Load

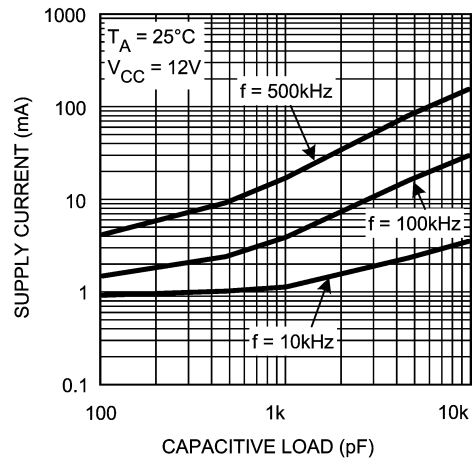

20079211

Rise and Fall Time vs Supply Voltage

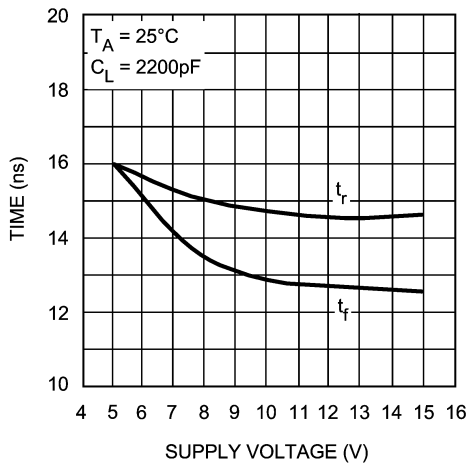

20079212

Rise and Fall Time vs Temperature

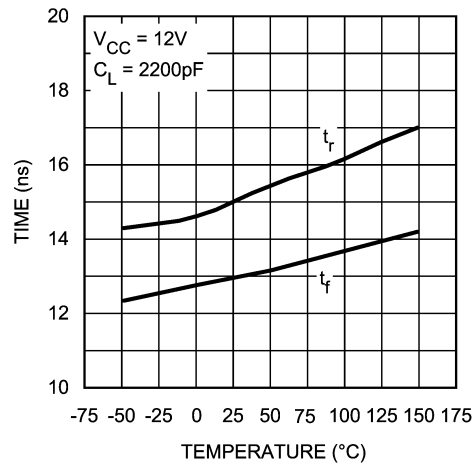

20079213

Rise and Fall Time vs Capacitive Load

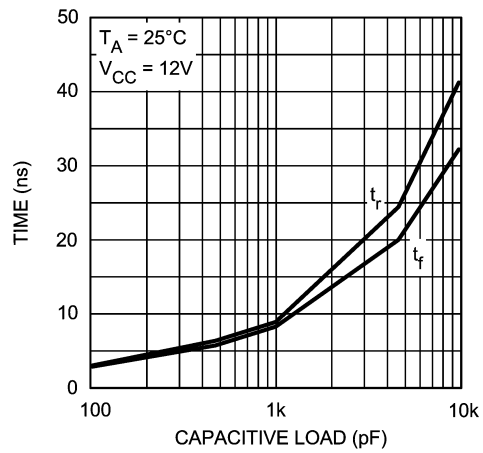

20079214

Delay Time vs Supply Voltage

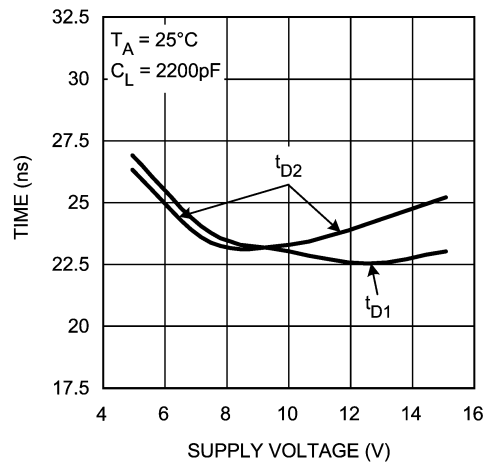

20079215

## Typical Performance Characteristics (Continued)

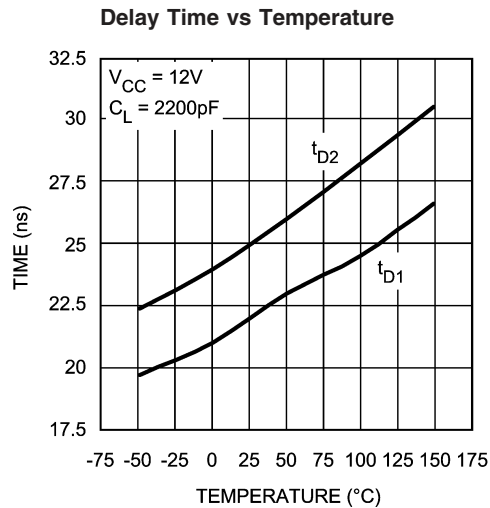

20079216

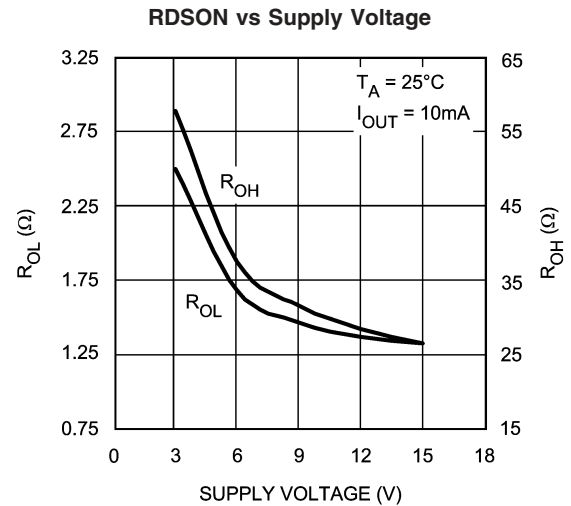

20079217

### UVLO Thresholds and Hysteresis vs Temperature

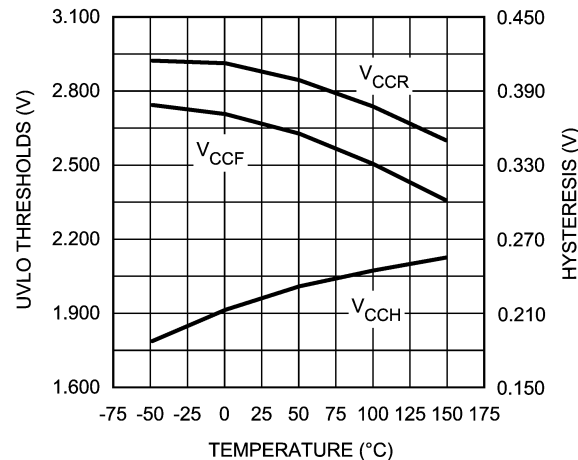

20079218

## Detailed Operating Description

LM5110 dual gate driver consists of two independent and identical driver channels with TTL compatible logic inputs and high current totem-pole outputs that source or sink current to drive MOSFET gates. The driver output consist of a compound structure with MOS and bipolar transistor operating in parallel to optimize current capability over a wide output voltage and operating temperature range. The bipolar device provides high peak current at the critical threshold region of the MOSFET VGS while the MOS devices provide rail-to-rail output swing. The totem pole output drives the MOSFET gate between the gate drive supply voltage  $V_{CC}$  and the power ground potential at the  $V_{EE}$  pin.

The control inputs of the drivers are high impedance CMOS buffers with TTL compatible threshold voltages. The negative supply of the input buffer is connected to the input ground pin IN\_REF. An internal level shifting circuit connects the logic input buffers to the totem pole output drivers. The level shift circuit and separate input/output ground pins provide the option of single supply or split supply configurations. When driving MOSFET gates from a single positive supply, the IN\_REF and  $V_{EE}$  pins are both connected to the power

ground. The LM5110 pinout was designed for compatibility with industry standard gate drivers in single supply gate driver applications. Pin 1 (IN\_REF) on the LM5110 is a no-connect on standard driver IC's. Connecting pin 1 to pin 3 ( $V_{EE}$ ) on the printed circuit board accommodates the pin-out of both the LM5110 and competitive drivers.

The isolated input/output grounds provide the capability to drive the MOSFET to a negative VGS voltage for a more robust and reliable off state. In split supply configuration, the IN\_REF pin is connected to the ground of the controller which drives the LM5110 inputs. The  $V_{EE}$  pin is connected to a negative bias supply that can range from the IN-REF as much as 14V below the  $V_{CC}$  gate drive supply. The maximum recommended voltage difference between  $V_{CC}$  and IN\_REF or between  $V_{CC}$  and  $V_{EE}$  is 14V. The minimum voltage difference between  $V_{CC}$  and IN\_REF is 3.5V.

Enhancement mode MOSFETs do not inherently require a negative bias on the gate to turn off the FET. However, certain applications may benefit from the capability of negative VGS voltage during turn-off including:

1. when the gate voltages cannot be held safely below the threshold voltage due to transients or coupling in the printed circuit board.



## Detailed Operating Description

(Continued)

- when driving low threshold MOSFETs at high junction temperatures
- when high switching speeds produce capacitive gate-drain current that lifts the internal gate potential of the MOSFET

The two driver channels of the LM5110 are designed as identical cells. Transistor matching inherent to integrated circuit manufacturing ensures that the ac and dc performance of the channels are nearly identical. Closely matched propagation delays allow the dual driver to be operated as a single driver if inputs and output pins are connected. The drive current capability in parallel operation is 2X the drive of either channel. Small differences in switching speed between the driver channels will produce a transient current (shoot-through) in the output stage when two output pins are connected to drive a single load. The efficiency loss for parallel operation has been characterized at various loads, supply voltages and operating frequencies. The power dissipation in the LM5110 increases by less than 1% relative to the dual driver configuration when operated as a single driver with inputs and outputs connected.

An Under-voltage lockout (UVLO) circuit is included in the LM5110, which senses the voltage difference between  $V_{CC}$  and the input ground pin, IN\_REF. When the  $V_{CC}$  to IN\_REF voltage difference falls below 2.7V both driver channels are disabled. The driver will resume normal operation when the  $V_{CC}$  to IN\_REF differential voltage exceeds approximately 2.9V. UVLO hysteresis prevents chattering during brown-out conditions.

The Shutdown pin (nSHDN) is a TTL compatible logic input provided to enable/disable both driver channels. When nSHDN is in the logic low state, the LM5110 is switched to a low power standby mode with total supply current less than 25  $\mu$ A. This function can be effectively used for start-up, thermal overload, or short circuit fault protection. It is recommended that this pin be connected to  $V_{CC}$  when the shutdown function is not being used. The shutdown pin has an internal 18 $\mu$ A current source pull-up to  $V_{CC}$ .

The input pins of non-inverting drivers have an internal 18 $\mu$ A current source pull-down to IN-REF. The input pins of inverting driver channels have neither pull-up nor pull-down current sources.

The LM5110 is available in dual non-inverting (-1), dual inverting (-2) and the combination inverting plus non-inverting (-3) configurations. All three configurations are offered in the SOIC-8 and LLP-10 plastic packages.

## Layout Considerations

Attention must be given to board layout when using LM5110. Some important considerations include:

- A Low ESR/ESL capacitor must be connected close to the IC and between the  $V_{CC}$  and  $V_{EE}$  pins to support

high peak currents being drawn from  $V_{CC}$  during turn-on of the MOSFET.

- Proper grounding is crucial. The drivers need a very low impedance path for current return to ground avoiding inductive loops. The two paths for returning current to ground are a) between LM5110 IN-REF pin and the ground of the circuit that controls the driver inputs, b) between LM5110  $V_{EE}$  pin and the source of the power MOSFET being driven. All these paths should be as short as possible to reduce inductance and be as wide as possible to reduce resistance. All these ground paths should be kept distinctly separate to avoid coupling between the high current output paths and the logic signals that drive the LM5110. A good method is to dedicate one copper plane in a multi-layered PCB to provide a common ground surface.
- With the rise and fall times in the range of 10 ns to 30 ns, care is required to minimize the lengths of current carrying conductors to reduce their inductance and EMI from the high di/dt transients generated by the LM5110.
- The LM5110 SOIC footprint is compatible with other industry standard drivers. Simply connect IN\_REF pin of the LM5110 to  $V_{EE}$  (pin 1 to pin 3) to operate the LM5110 in a standard single supply configuration.
- If either channel is not being used, the respective input pin (IN\_A or IN\_B) should be connected to either IN\_REF or  $V_{CC}$  to avoid spurious output signals. If the shutdown feature is not used, the nSHDN pin should be connected to  $V_{CC}$  to avoid erratic behavior that would result if system noise were coupled into a floating 'nSHDN' pin.

## Thermal Performance

### INTRODUCTION

The primary goal of thermal management is to maintain the integrated circuit (IC) junction temperature ( $T_J$ ) below a specified maximum operating temperature to ensure reliability. It is essential to estimate the maximum  $T_J$  of IC components in worst case operating conditions. The junction temperature is estimated based on the power dissipated in the IC and the junction to ambient thermal resistance  $\theta_{JA}$  for the IC package in the application board and environment. The  $\theta_{JA}$  is not a given constant for the package and depends on the printed circuit board design and the operating environment.

### DRIVE POWER REQUIREMENT CALCULATIONS IN LM5110

The LM5110 dual low side MOSFET driver is capable of sourcing/sinking 3A/5A peak currents for short intervals to drive a MOSFET without exceeding package power dissipation limits. High peak currents are required to switch the MOSFET gate very quickly for operation at high frequencies.

## Thermal Performance (Continued)

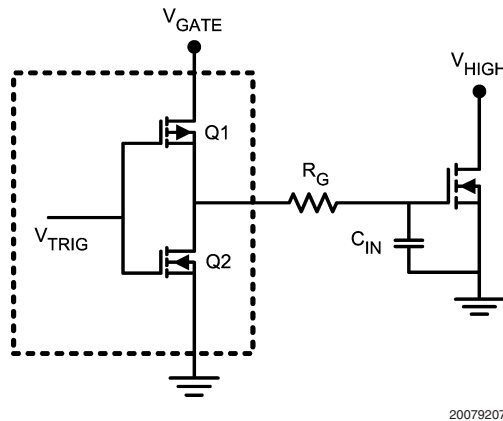

FIGURE 2.

The schematic above shows a conceptual diagram of the LM5110 output and MOSFET load. Q1 and Q2 are the switches within the gate driver.  $R_G$  is the gate resistance of the external MOSFET, and  $C_{IN}$  is the equivalent gate capacitance of the MOSFET. The gate resistance  $R_G$  is usually very small and losses in it can be neglected. The equivalent gate capacitance is a difficult parameter to measure since it is the combination of  $C_{GS}$  (gate to source capacitance) and  $C_{GD}$  (gate to drain capacitance). Both of these MOSFET capacitances are not constants and vary with the gate and drain voltage. The better way of quantifying gate capacitance is the total gate charge  $Q_G$  in coulombs.  $Q_G$  combines the charge required by  $C_{GS}$  and  $C_{GD}$  for a given gate drive voltage  $V_{GATE}$ .

Assuming negligible gate resistance, the total power dissipated in the MOSFET driver due to gate charge is approximated by

$$P_{DRIVER} = V_{GATE} \times Q_G \times F_{SW}$$

Where

$F_{SW}$  = switching frequency of the MOSFET.

As an example, consider the MOSFET MTD6N15 whose gate charge specified as 30 nC for  $V_{GATE} = 12V$ .

The power dissipation in the driver due to charging and discharging of MOSFET gate capacitances at switching frequency of 300 kHz and  $V_{GATE}$  of 12V is equal to

$$P_{DRIVER} = 12V \times 30 \text{ nC} \times 300 \text{ kHz} = 0.108W.$$

If both channels of the LM5110 are operating at equal frequency with equivalent loads, the total losses will be twice as this value which is 0.216W.

In addition to the above gate charge power dissipation, - transient power is dissipated in the driver during output transitions. When either output of the LM5110 changes state, current will flow from  $V_{CC}$  to  $V_{EE}$  for a very brief interval of time through the output totem-pole N and P channel MOSFETs. The final component of power dissipation in the driver is the power associated with the quiescent bias current consumed by the driver input stage and Under-voltage lockout sections.

Characterization of the LM5110 provides accurate estimates of the transient and quiescent power dissipation components. At 300 kHz switching frequency and 30 nC load used

in the example, the transient power will be 8 mW. The 1 mA nominal quiescent current and 12V  $V_{GATE}$  supply produce a 12 mW typical quiescent power.

Therefore the total power dissipation

$$P_D = 0.216 + 0.008 + 0.012 = 0.236W.$$

We know that the junction temperature is given by

$$T_J = P_D \times \theta_{JA} + T_A$$

Or the rise in temperature is given by

$$T_{RISE} = T_J - T_A = P_D \times \theta_{JA}$$

For SOIC-8 package  $\theta_{JA}$  is estimated as 170°C/W for the conditions of natural convection.

Therefore  $T_{RISE}$  is equal to

$$T_{RISE} = 0.236 \times 170 = 40.1^\circ\text{C}$$

For LLP-10 package, the integrated circuit die is attached to leadframe die pad which is soldered directly to the printed circuit board. This substantially decreases the junction to ambient thermal resistance ( $\theta_{JA}$ ).  $\theta_{JA}$  as low as 40°C/W is achievable with the LLP10 package. The resulting  $T_{RISE}$  for the dual driver example above is thereby reduced to just 9.5 degrees.

### CONTINUOUS CURRENT RATING OF LM5110

The LM5110 can deliver pulsed source/sink currents of 3A and 5A to capacitive loads. In applications requiring continuous load current (resistive or inductive loads), package power dissipation, limits the LM5110 current capability far below the 5A sink/3A source capability. Rated continuous current can be estimated both when sourcing current to or sinking current from the load. For example when sinking, the maximum sink current can be calculated as

$$I_{SINK(MAX)} := \sqrt{\frac{T_J(MAX) - T_A}{\theta_{JA} \cdot R_{DS(ON)}}$$

where  $R_{DS(on)}$  is the on resistance of lower MOSFET in the output stage of LM5110.

Consider  $T_J(max)$  of 125°C and  $\theta_{JA}$  of 170°C/W for an SO-8 package under the condition of natural convection and no air flow. If the ambient temperature ( $T_A$ ) is 60°C, and the  $R_D$ -

## Thermal Performance (Continued)

s(on) of the LM5110 output at  $T_J(\text{max})$  is  $2.5\Omega$ , this equation yields  $I_{\text{SINK}}(\text{max})$  of 391mA which is much smaller than 5A peak pulsed currents.

Similarly, the maximum continuous source current can be calculated as

$$I_{\text{SOURCE}}(\text{MAX}) := \frac{T_J(\text{MAX}) - T_A}{\theta_{JA} \cdot V_{\text{DIODE}}}$$

where  $V_{\text{DIODE}}$  is the voltage drop across hybrid output stage which varies over temperature and can be assumed to be about 1.1V at  $T_J(\text{max})$  of  $125^\circ\text{C}$ . Assuming the same parameters as above, this equation yields  $I_{\text{SOURCE}}(\text{max})$  of 347mA.

## Physical Dimensions inches (millimeters)

unless otherwise noted

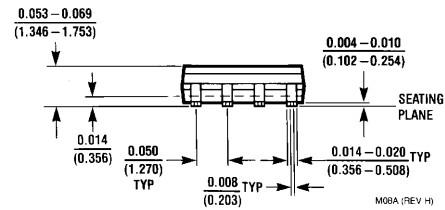
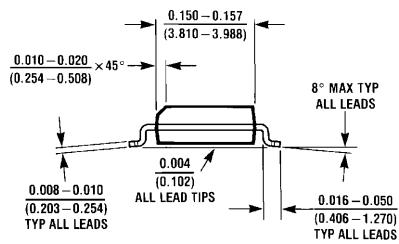
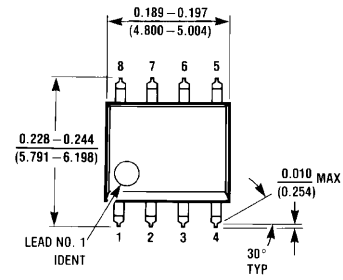

NOTES: UNLESS OTHERWISE SPECIFIED

- STANDARD LEAD FINISH TO BE 200 MICRONS/5.08 MICROMETERS MINIMUM LEAD/TIN(SOLDER) ON COPPER.
- DIMENSION DOES NOT INCLUDE MOLD FLASH.
- REFERENCE JEDEC REGISTRATION MS-012, VARIATION AA, DATED MAY 1990.

**8-Lead SOIC Package**  
**NS Package Number M08A**

**Physical Dimensions** inches (millimeters) unless otherwise noted (Continued)

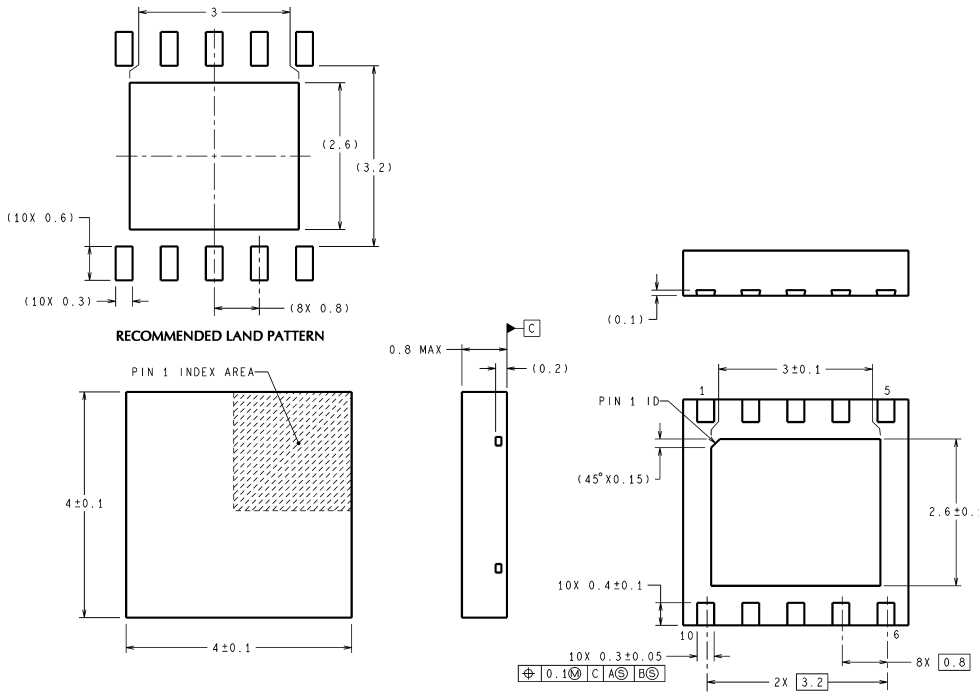

SDC10A (Rev A)

NOTES: UNLESS OTHERWISE SPECIFIED

1. FOR SOLDER THICKNESS AND COMPOSITION, SEE "SOLDER INFORMATION" IN THE PACKAGING SECTION OF THE NATIONAL SEMICONDUCTOR WEB PAGE ([www.national.com](http://www.national.com)).
2. MAXIMUM ALLOWABLE METAL BURR ON LEAD TIPS AT THE PACKAGE EDGES IS 76 MICRONS.
3. NO JEDEC REGISTRATION AS OF MAY 2003.

**10-Lead LLP Package  
NS Package Number SDC10A**

**LIFE SUPPORT POLICY**

NATIONAL'S PRODUCTS ARE NOT AUTHORIZED FOR USE AS CRITICAL COMPONENTS IN LIFE SUPPORT DEVICES OR SYSTEMS WITHOUT THE EXPRESS WRITTEN APPROVAL OF THE PRESIDENT AND GENERAL COUNSEL OF NATIONAL SEMICONDUCTOR CORPORATION. As used herein:

1. Life support devices or systems are devices or systems which, (a) are intended for surgical implant into the body, or (b) support or sustain life, and whose failure to perform when properly used in accordance with instructions for use provided in the labeling, can be reasonably expected to result in a significant injury to the user.
2. A critical component is any component of a life support device or system whose failure to perform can be reasonably expected to cause the failure of the life support device or system, or to affect its safety or effectiveness.

**BANNED SUBSTANCE COMPLIANCE**

National Semiconductor certifies that the products and packing materials meet the provisions of the Customer Products Stewardship Specification (CSP-9-111C2) and the Banned Substances and Materials of Interest Specification (CSP-9-111S2) and contain no "Banned Substances" as defined in CSP-9-111S2.



**National Semiconductor  
Americas Customer  
Support Center**  
Email: [new.feedback@nsc.com](mailto:new.feedback@nsc.com)  
Tel: 1-800-272-9959

**National Semiconductor  
Europe Customer Support Center**  
Fax: +49 (0) 180-530 85 86  
Email: [europe.support@nsc.com](mailto:europe.support@nsc.com)  
Deutsch Tel: +49 (0) 69 9508 6208  
English Tel: +44 (0) 870 24 0 2171  
Français Tel: +33 (0) 1 41 91 8790

**National Semiconductor  
Asia Pacific Customer  
Support Center**  
Email: [ap.support@nsc.com](mailto:ap.support@nsc.com)

**National Semiconductor  
Japan Customer Support Center**  
Fax: 81-3-5639-7507  
Email: [jpn.feedback@nsc.com](mailto:jpn.feedback@nsc.com)  
Tel: 81-3-5639-7560

[www.national.com](http://www.national.com)