



February 1995

LM709 Operational Amplifier

General Description

The LM709 series is a monolithic operational amplifier intended for general-purpose applications. Operation is completely specified over the range of voltages commonly used for these devices. The design, in addition to providing high gain, minimizes both offset voltage and bias currents. Further, the class-B output stage gives a large output capability with minimum power drain.

External components are used to frequency compensate the amplifier. Although the unity-gain compensation network specified will make the amplifier unconditionally stable in all feedback configurations, compensation can be tailored to optimize high-frequency performance for any gain setting.

The LM709C is the commercial-industrial version of the LM709. It is identical to the LM709 except that it is specified for operation from 0°C to +70°C.

LM709 Operational Amplifier

Connection Diagrams

Metal Can Package

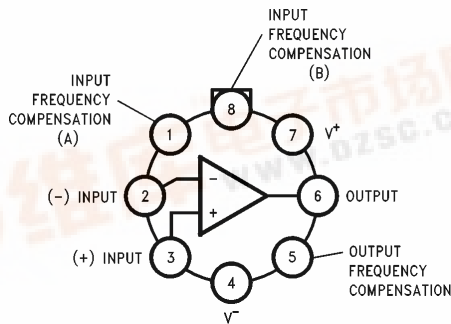

TL/H/11477-4

Order Number LM709AH, LM709H or LM709CH
See NS Package Number H08C

Dual-In-Line Package

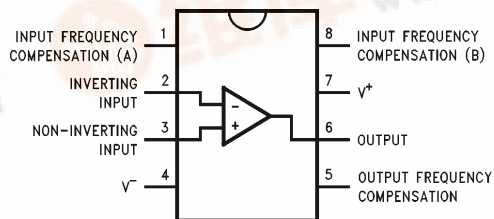

TL/H/11477-6

Order Number LM709CN-8
See NS Package Number N08E

Dual-In-Line Package

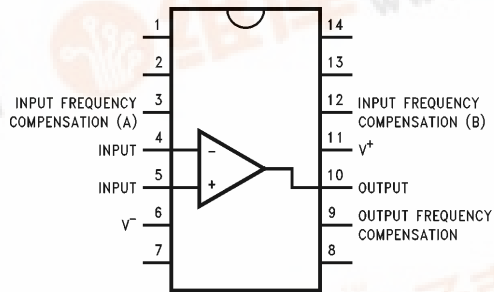

TL/H/11477-5

Order Number LM709CN
See NS Package Number N14A



Absolute Maximum Ratings (Note 3)

If Military/Aerospace specified devices are required, please contact the National Semiconductor Sales Office/Distributors for availability and specifications.

Supply Voltage LM709/LM709A/LM709C	±18V
Power Dissipation (Note 1) LM709/LM709A LM709C	300 mW 250 mW
Differential Input Voltage LM709/LM709A/LM709C	±5V
Input Voltage LM709/LM709A/LM709C	±10V
Output Short-Circuit Duration ($T_A = +25^\circ\text{C}$) LM709/LM709A/LM709C	5 seconds

Storage Temperature Range LM709/LM709A/LM709C	-65°C to +150°C
Lead Temperature (Soldering, 10 sec.) LM709/LM709A/LM709C	300°C

Operating Ratings (Note 3)

Junction Temperature Range (Note 1) LM709/LM709A LM709C	-55°C to +150°C 0°C to +100°C
Thermal Resistance (θ_{JA}) H Package 8-Pin N Package 14-Pin N Package	150°C/W, (θ_{JC}) 45°C/W 134°C/W 109°C/W

Electrical Characteristics (Note 2)

Parameter	Conditions	LM709A			LM709			LM709C			Units
		Min	Typ	Max	Min	Typ	Max	Min	Typ	Max	
Input Offset Voltage	$T_A = 25^\circ\text{C}$, $R_S \leq 10\text{ k}\Omega$	0.6	2.0		1.0	5.0		2.0	7.5		mV
Input Bias Current	$T_A = 25^\circ\text{C}$	100	200		200	500		300	1500		nA
Input Offset Current	$T_A = 25^\circ\text{C}$	10	50		50	200		100	500		nA
Input Resistance	$T_A = 25^\circ\text{C}$	350	700		150	400		50	250		k Ω
Output Resistance	$T_A = 25^\circ\text{C}$	150			150			150			Ω
Supply Current	$T_A = 25^\circ\text{C}$, $V_S = \pm 15\text{V}$	2.5	3.6		2.6	5.5		2.6	6.6		mA
Transient Response Risetime Overshoot	$V_{IN} = 20\text{ mV}$, $C_L \leq 100\text{ pF}$ $T_A = 25^\circ\text{C}$			1.5	0.3	1.0		0.3	1.0		μs %
Slew Rate	$T_A = 25^\circ\text{C}$	0.25			0.25			0.25			V/ μs
Input Offset Voltage	$R_S \leq 10\text{ k}\Omega$		3.0			6.0			10		mV
Average Temperature Coefficient of Input Offset Voltage	$R_S = 50\Omega$ $T_A = 25^\circ\text{C}$ to T_{MAX} $T_A = 25^\circ\text{C}$ to T_{MIN} $R_S = 10\text{ k}\Omega$ $T_A = 25^\circ\text{C}$ to T_{MAX} $T_A = 25^\circ\text{C}$ to T_{MIN}	1.8	10		3.0			6.0			$\mu\text{V}/^\circ\text{C}$
Large Signal Voltage Gain	$V_S = \pm 15\text{V}$, $R_L \geq 2\text{ k}\Omega$ $V_{OUT} = \pm 10\text{V}$	25	70		25	45	70	15	45		V/mV
Output Voltage Swing	$V_S = \pm 15\text{V}$, $R_L = 10\text{ k}\Omega$ $V_S = \pm 15\text{V}$, $R_L = 2\text{ k}\Omega$	±12 ±10	±14 ±13		±12 ±10	±14 ±13		±12 ±10	±14 ±13		V
Input Voltage Range	$V_S = \pm 15\text{V}$	±8			±8	±10		±8	±10		V
Common-Mode Rejection Ratio	$R_S \leq 10\text{ k}\Omega$	80	110		70	90		65	90		dB
Supply Voltage Rejection Ratio	$R_S \leq 10\text{ k}\Omega$	40	100		25	150		25	200		$\mu\text{V}/\text{V}$
Input Offset Current	$T_A = T_{MAX}$ $T_A = T_{MIN}$	3.5 40	50 250		20 100	200 500		75 125	400 750		nA
Input Bias Current	$T_A = T_{MIN}$	0.3	0.6		0.5	1.5		0.36	2.0		μA
Input Resistance	$T_A = T_{MIN}$	85	170		40	100		50	250		k Ω

Note 1: For operating at elevated temperatures, the device must be derated based on a 150°C maximum junction temperature for LM709/LM709A and 100°C maximum for L709C. For operating at elevated temperatures, the device must be derated based on thermal resistance θ_{JA} , $T_{J(MAX)}$ and T_A .

Note 2: These specifications apply for $-55^\circ\text{C} \leq T_A \leq +125^\circ\text{C}$ for the LM709/LM709A and $0^\circ\text{C} \leq T_A \leq +70^\circ\text{C}$ for the LM709C with the following conditions: $\pm 9\text{V} \leq V_S \leq \pm 15\text{V}$, $C_1 = 5000\text{ pF}$, $R_1 = 1.5\text{ k}\Omega$, $C_2 = 200\text{ pF}$ and $R_2 = 51\Omega$.

Note 3: Absolute Maximum Ratings indicate limits which if exceeded may result in damage. Operating Ratings are conditions where the device is expected to be functional but not necessarily within the guaranteed performance limits. For guaranteed specifications and test conditions, see the Electrical Characteristics.

Schematic Diagram **

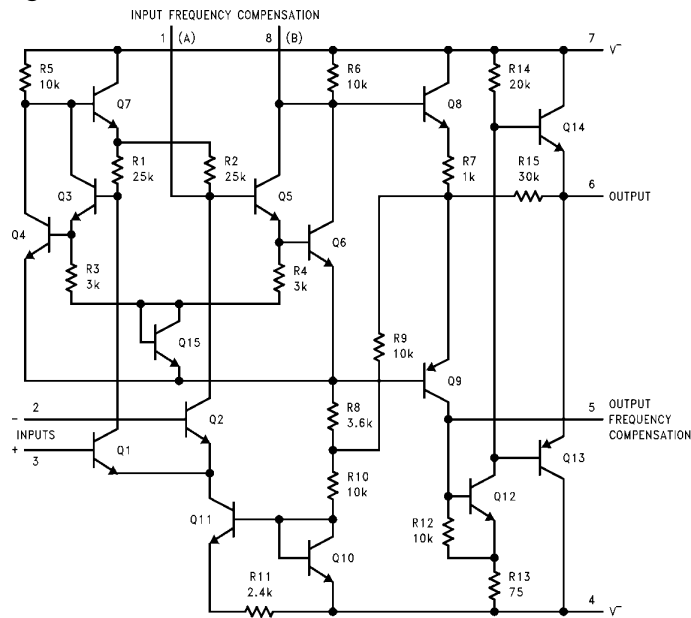

TL/H/11477-1

Typical Applications **

Unity Gain Inverting Amplifier

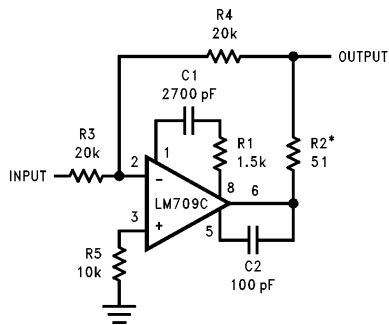

TL/H/11477-2

FET Operational Amplifier

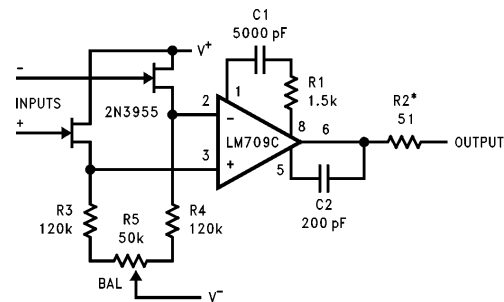

TL/H/11477-3

Voltage Follower

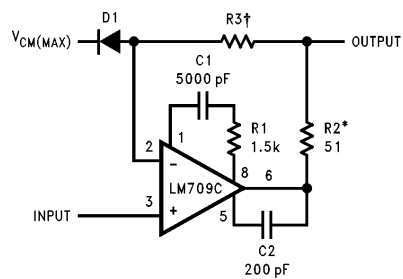

TL/H/11477-7

Offset Balancing Circuit

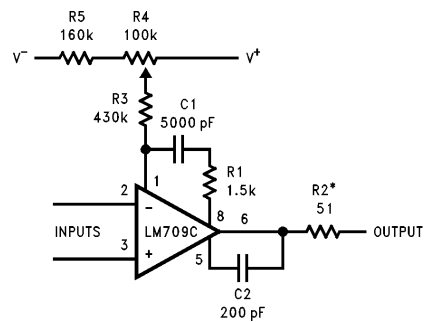

TL/H/11477-8

*To be used with any capacitive loading on output.
 **Pin connections shown are for metal can package.
 †Should be equal to DC source resistance on input.

Guaranteed Performance Characteristics

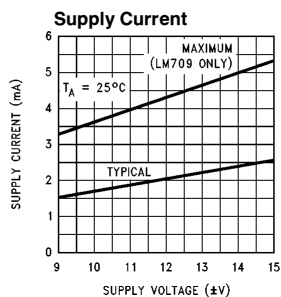
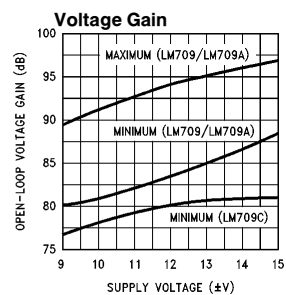
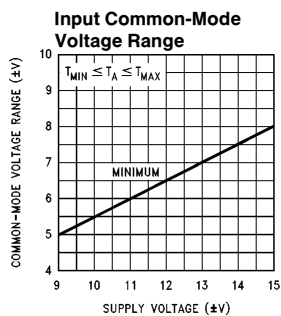
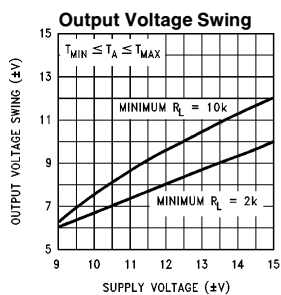

TL/H/11477-9

Typical Performance Characteristics

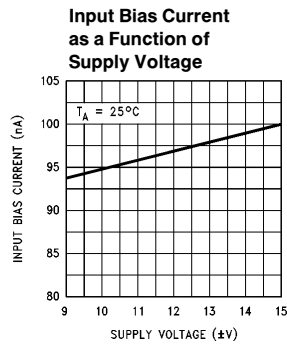
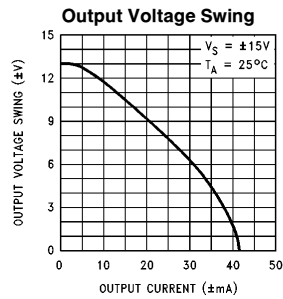
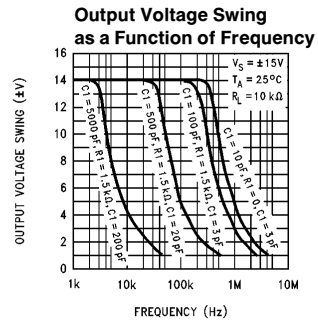
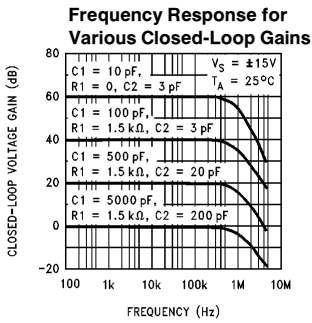
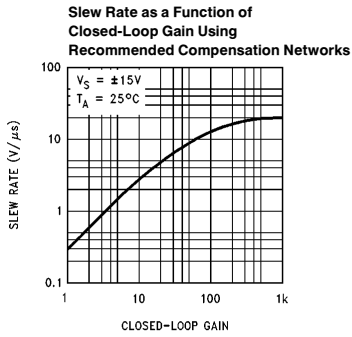
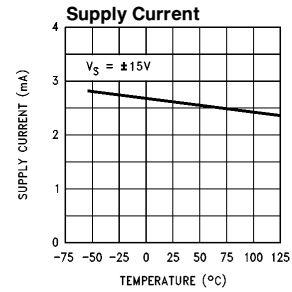
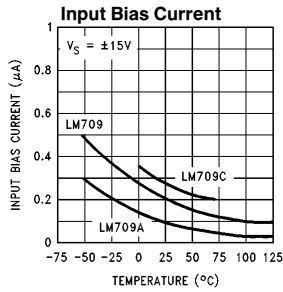
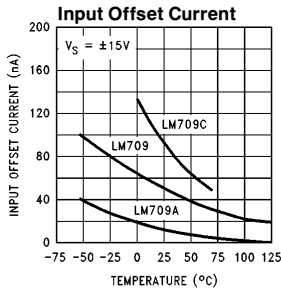

TL/H/11477-10

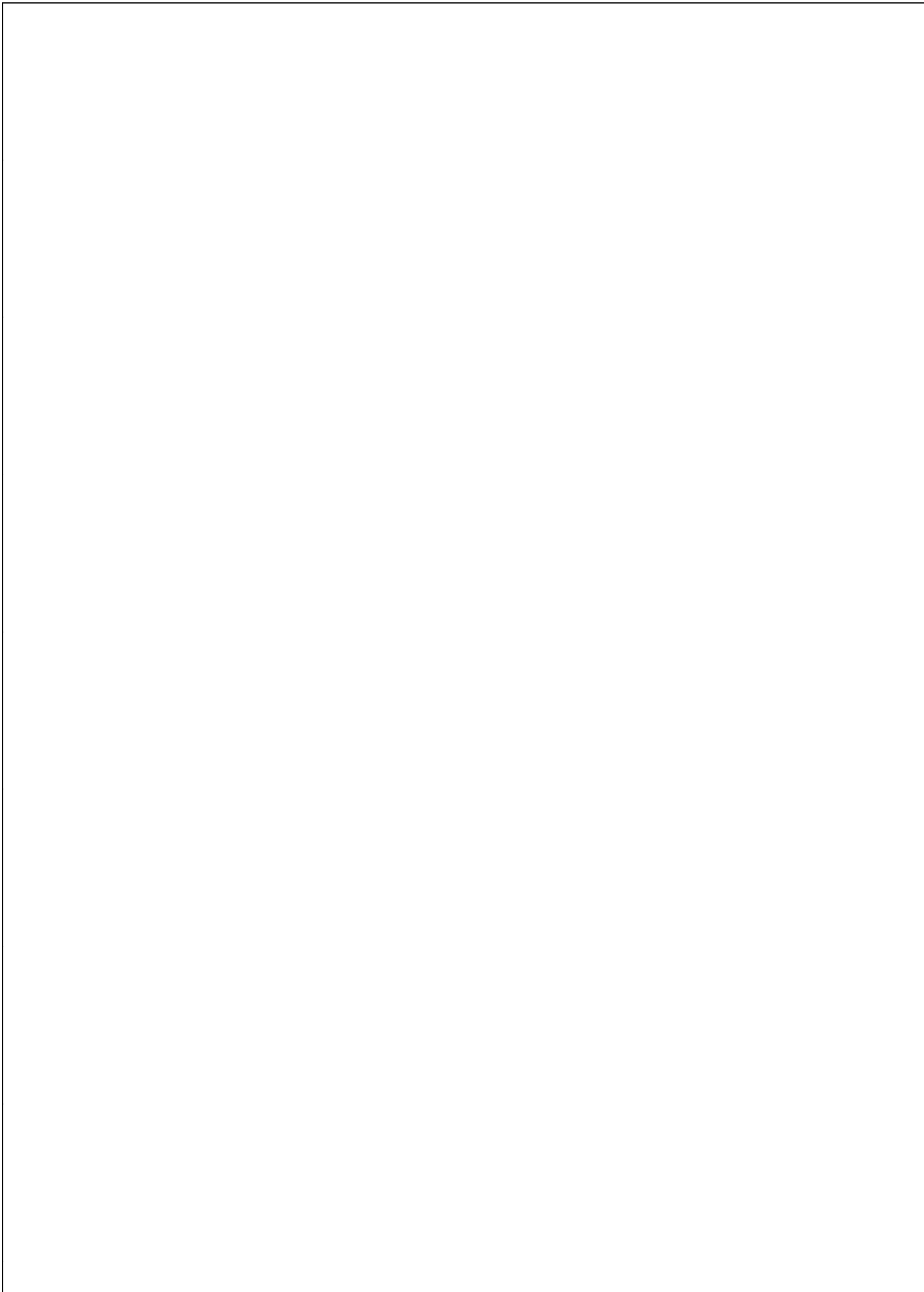

Physical Dimensions inches (millimeters) (Continued)

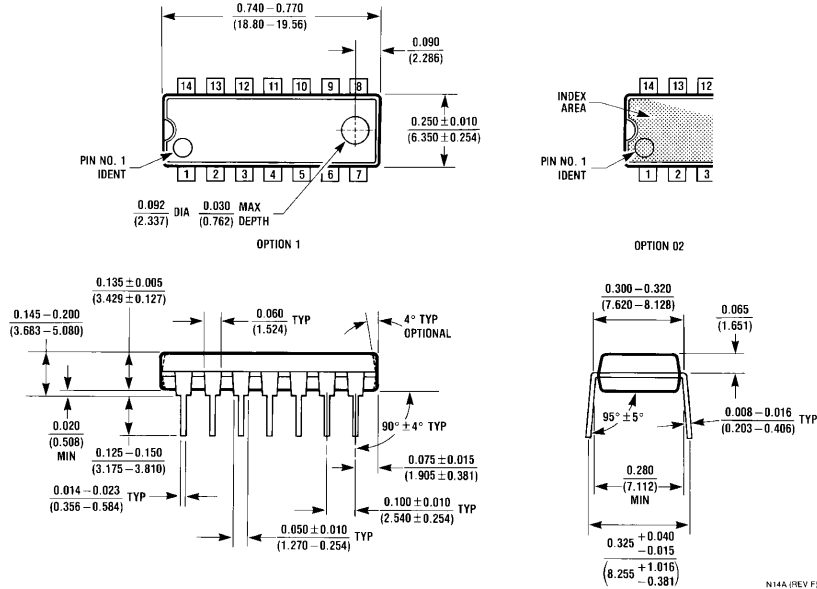

14-Lead Molded Dual-In-Line Package (N)
Order Number LM709CN
NS Package Number N14A

N14A (REV F)

LIFE SUPPORT POLICY

NATIONAL'S PRODUCTS ARE NOT AUTHORIZED FOR USE AS CRITICAL COMPONENTS IN LIFE SUPPORT DEVICES OR SYSTEMS WITHOUT THE EXPRESS WRITTEN APPROVAL OF THE PRESIDENT OF NATIONAL SEMICONDUCTOR CORPORATION. As used herein:

1. Life support devices or systems are devices or systems which, (a) are intended for surgical implant into the body, or (b) support or sustain life, and whose failure to perform, when properly used in accordance with instructions for use provided in the labeling, can be reasonably expected to result in a significant injury to the user.
2. A critical component is any component of a life support device or system whose failure to perform can be reasonably expected to cause the failure of the life support device or system, or to affect its safety or effectiveness.



National Semiconductor Corporation
 1111 West Bardin Road
 Arlington, TX 76017
 Tel: 1(800) 272-9959
 Fax: 1(800) 737-7018

National Semiconductor Europe
 Fax: (+49) 0-180-530 85 86
 Email: cnjwge@tevm2.nsc.com
 Deutsch Tel: (+49) 0-180-530 85 85
 English Tel: (+49) 0-180-532 78 32
 Français Tel: (+49) 0-180-532 93 58
 Italiano Tel: (+49) 0-180-534 16 80

National Semiconductor Hong Kong Ltd.
 13th Floor, Straight Block,
 Ocean Centre, 5 Canton Rd.
 Tsimshatsui, Kowloon
 Hong Kong
 Tel: (852) 2737-1600
 Fax: (852) 2736-9960

National Semiconductor Japan Ltd.
 Tel: 81-043-299-2309
 Fax: 81-043-299-2408