



March 2001

# LMS33460

## 3V Under Voltage Detector

### General Description

The LMS33460 is an under voltage detector with a 3.0V threshold and extremely low power consumption. The LMS33460 is specifically designed to accurately monitor power supplies. It is especially suited to battery powered systems where low quiescent current and small size are required. This IC generates an active output whenever the input voltage drops below 3.0 Volts.

This part uses a precision on-chip voltage reference and a comparator to measure the input voltage. Built in hysteresis helps to prevent erratic operation in the presence of noise. The UVD is available in the ultra-miniature SC70-5 package.

### Features

- Ultra low Power
- 3.0V detection
- $V_{IN}$  Range: 0.8V to 7.0V
- Open drain output
- Ultra-small SC70-5 package
- Extended Temperature range ( $-40^{\circ}\text{C}$  to  $85^{\circ}\text{C}$ )
- Ultra Low Quiescent current ( $1\mu\text{A}$  typ)

### Applications

- Low battery voltage detector
- Power Fail Indicator
- Processor Reset Generator
- Battery Backup Control
- Battery Operated Equipment
- Hand-held Instruments

### Circuit Block Diagram

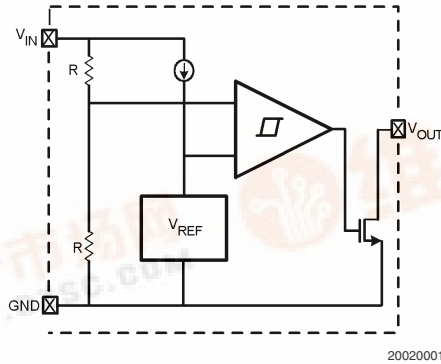

20020001

### Typical Application

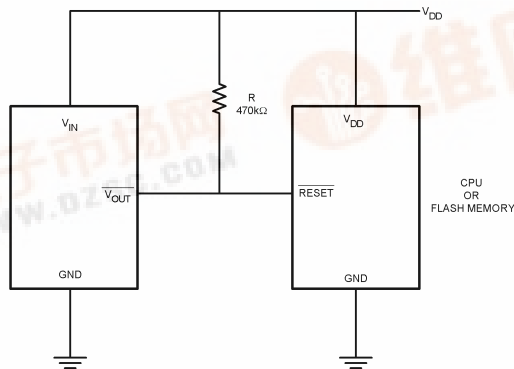

20020003

LMS33460 3V Under Voltage Detector



## Typical Application (Continued)

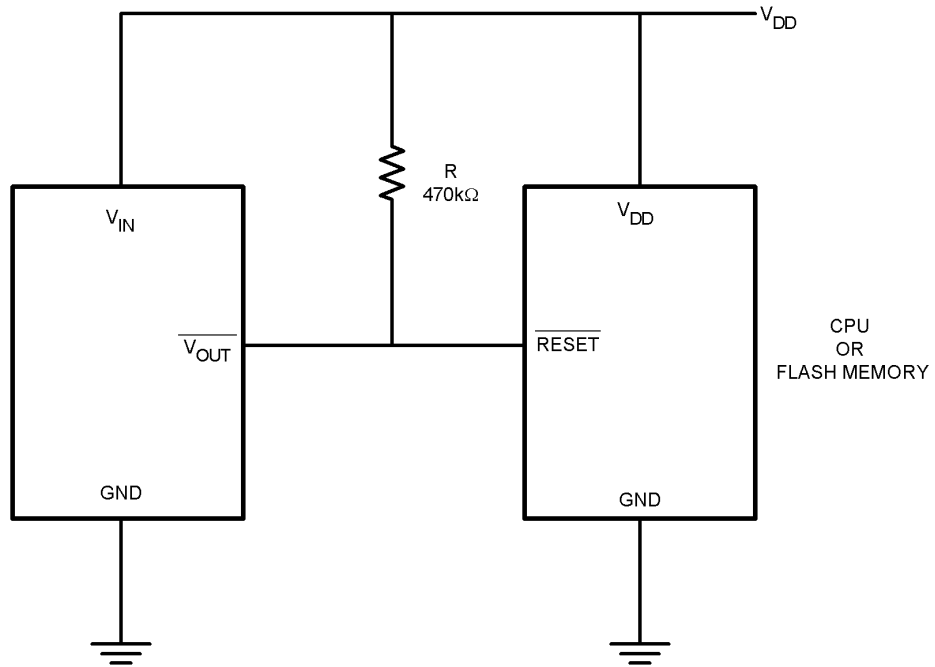

20020003

## Connection Diagram

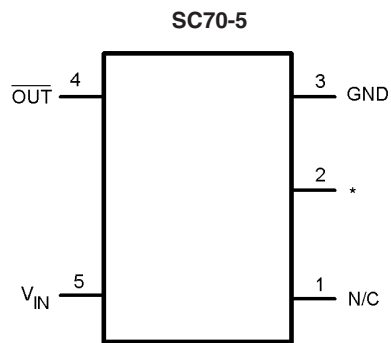

\* Internally connected to ground. This pin should be either left floating or connected to ground.

20020002

Top View

## Ordering Information

Package	Part Number	Package Marking	Transport Media	NSC Drawing
5-Pin SC70-5	LMS33460MG	C33	1k Units Tape and Reel	MAA05A
	LMS33460MGX		3k Units Tape and Reel	

**Absolute Maximum Ratings** (Note 1)

If Military/Aerospace specified devices are required, please contact the National Semiconductor Sales Office/Distributors for availability and specifications.

Input Voltage to GND	8.0V
Output Voltage to GND	8.0V
Output Continuous Output Current	30mA
Vapor Phase IR Convection Reflow	240°C
ESD Rating (Note 4)	

Human Body Model	2500V
Machine Model	200V
$T_{JMAX}$ (Note 3)	150°C
$\theta_{JA}$ (Note 3)	478°C/W

**Temperature Range**

Operating Junction	-40°C to +85°C
Storage Temperature Range	-65°C to +150°C

**Electrical Characteristics**

Unless otherwise specified, all limits guaranteed for  $T_J = 25^\circ\text{C}$ . **Boldface** limits apply at the temperature extremes.

Symbol	Parameter	Conditions	Min	Typ	Max	Units
$V_{DET}$	Detector Threshold	$V_{IN}$ Falling	2.85	3.0	3.15	V
$V_{HYS}$	Detector Voltage Hysteresis	$V_{IN}$ Rising	0.095	0.155	0.215	V
$I_{IN}$	Input Supply Current	$V_{IN} = 2.87\text{V}$	–	1.0	2.2	$\mu\text{A}$
		$V_{IN} = 4.7\text{V}$	–	1.2	3.6	$\mu\text{A}$
		$V_{IN} = 7.0\text{V}$ (Note 3)	–	25	200	$\mu\text{A}$
$V_{IN(MAX)}$	Maximum Operating Voltage		–	–	7.0	V
$V_{IN(MIN)}$	Maximum Operating Voltage (Note 2)			0.7	1.1	V
				<b>1.0</b>	<b>1.3</b>	
$I_{OUT(LOW)}$	Output Current Low	$V_{OUT} = 0.05\text{V}$ , $V_{IN} = 1.1\text{V}$	0.01	0.6		mA
		$V_{OUT} = 0.50\text{V}$ , $V_{IN} = 1.5\text{V}$	2	11		
$T_{pdHL}$	Output Delay Time Output Transition High to Low $C_L = 10\text{pF}$ , $R_L = 470\text{k}\Omega$		–	70	130	$\mu\text{sec}$
$\Delta V_{DET}/\Delta T$	Detect Voltage Temperature Coefficient		–	<b><math>\pm 120</math></b>	–	PPM/°C

**Note 1:** Absolute maximum ratings indicate limits beyond which damage to the device may occur. Electrical specifications do not apply when operating the device beyond its rated operating conditions.

**Note 2:** Temperature range specifications is guaranteed by design.

**Note 3:** Quiescent current will increase substantially above 5.5 volts, but is very low in the normal range below 5.5 volts.

**Note 4:** Human body model, 1.5k $\Omega$  in series with 100pF. Machine model, 0 $\Omega$  in series with 200pF.

## Typical Characteristics

( $T_A = 25^\circ\text{C}$ ,  $R_L = 470\text{k}\Omega$  and  $C_L = 10\text{pF}$  unless otherwise noted).

Supply Current vs. Input Voltage

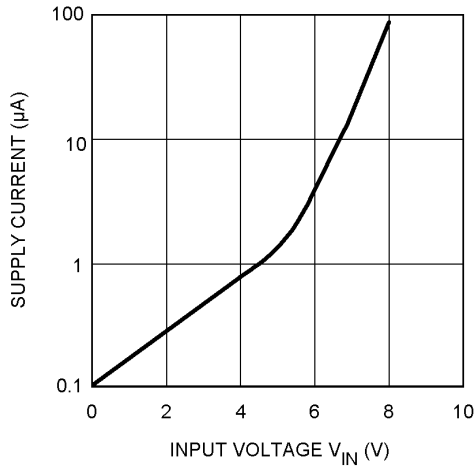

20020004

Detector Threshold vs. Temperature

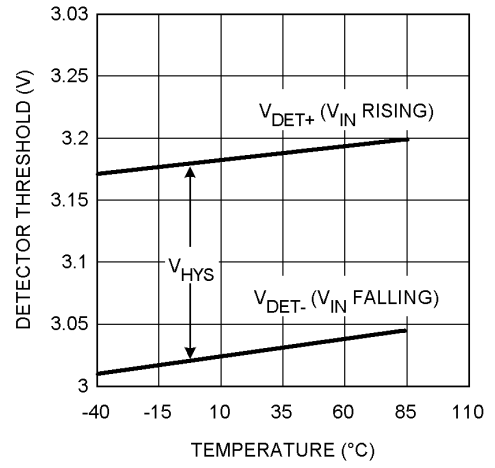

20020005

Output Current vs. Input Voltage

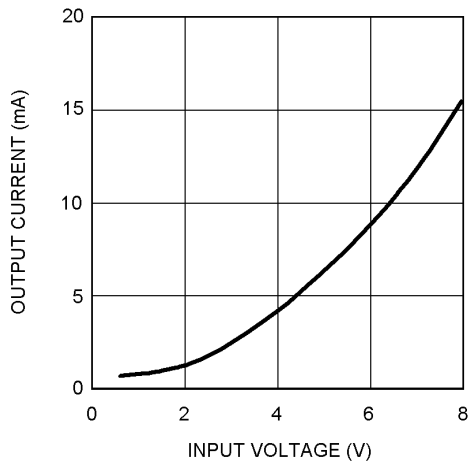

20020006

Output Delay Time vs. Temperature

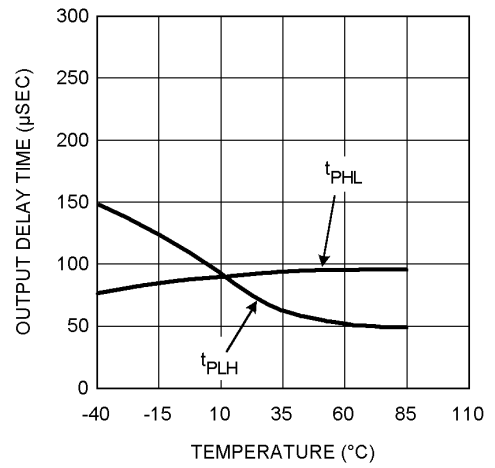

20020007

### Application Circuit Information

The LMS33460 is a micro power under voltage sensing circuit with an open drain output configuration, which requires a pull resistor.

The LMS33460 features a voltage reference, a comparator with precise thresholds and built in hysteresis to prevent erratic reset operation.

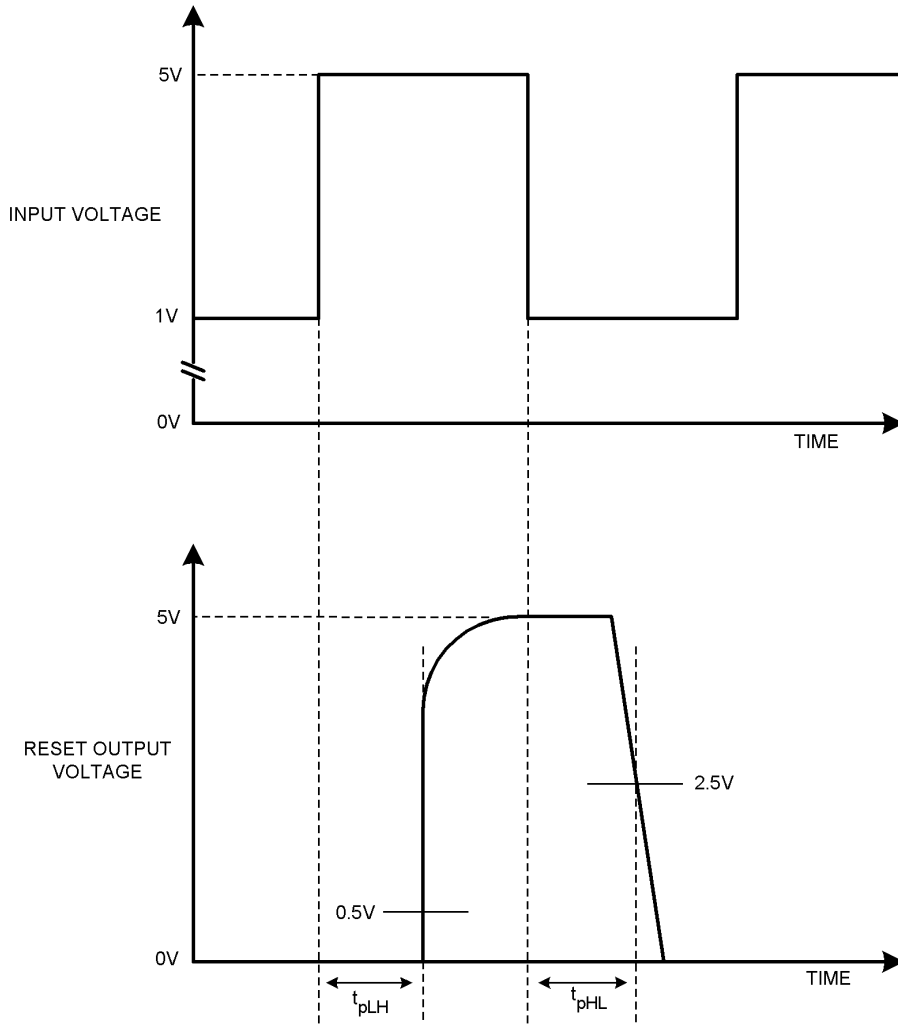

20020008

FIGURE 1. Propagation Delay

**Physical Dimensions** inches (millimeters) unless otherwise noted

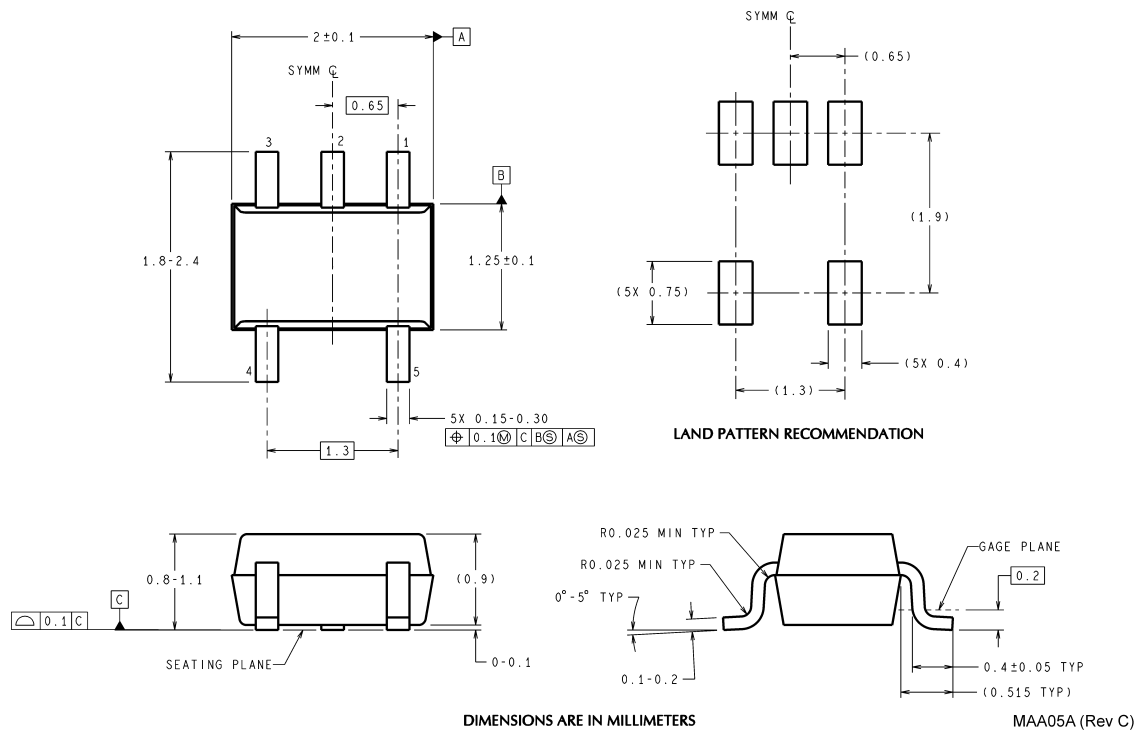

**5-Pin SC70-5  
NSC Package Number MAA05A**

National does not assume any responsibility for use of any circuitry described, no circuit patent licenses are implied and National reserves the right at any time without notice to change said circuitry and specifications.

For the most current product information visit us at [www.national.com](http://www.national.com).

**LIFE SUPPORT POLICY**

NATIONAL'S PRODUCTS ARE NOT AUTHORIZED FOR USE AS CRITICAL COMPONENTS IN LIFE SUPPORT DEVICES OR SYSTEMS WITHOUT THE EXPRESS WRITTEN APPROVAL OF THE PRESIDENT AND GENERAL COUNSEL OF NATIONAL SEMICONDUCTOR CORPORATION. As used herein:

1. Life support devices or systems are devices or systems which, (a) are intended for surgical implant into the body, or (b) support or sustain life, and whose failure to perform when properly used in accordance with instructions for use provided in the labeling, can be reasonably expected to result in a significant injury to the user.
2. A critical component is any component of a life support device or system whose failure to perform can be reasonably expected to cause the failure of the life support device or system, or to affect its safety or effectiveness.

**BANNED SUBSTANCE COMPLIANCE**

National Semiconductor certifies that the products and packing materials meet the provisions of the Customer Products Stewardship Specification (CSP-9-111C2) and the Banned Substances and Materials of Interest Specification (CSP-9-111S2) and contain no "Banned Substances" as defined in CSP-9-111S2.

 **National Semiconductor  
Americas Customer  
Support Center**  
Email: [new.feedback@nsc.com](mailto:new.feedback@nsc.com)  
Tel: 1-800-272-9959

**National Semiconductor  
Europe Customer Support Center**  
Fax: +49 (0) 180-530 85 86  
Email: [europe.support@nsc.com](mailto:europe.support@nsc.com)  
Deutsch Tel: +49 (0) 69 9508 6208  
English Tel: +44 (0) 870 24 0 2171  
Français Tel: +33 (0) 1 41 91 8790

**National Semiconductor  
Asia Pacific Customer  
Support Center**  
Email: [ap.support@nsc.com](mailto:ap.support@nsc.com)

**National Semiconductor  
Japan Customer Support Center**  
Fax: 81-3-5639-7507  
Email: [jpn.feedback@nsc.com](mailto:jpn.feedback@nsc.com)  
Tel: 81-3-5639-7560