



June 2003

LMV321/LMV358/LMV324 Single/Dual/Quad General Purpose, Low Voltage, Rail-to-Rail Output Operational Amplifiers

General Description

The LMV358/324 are low voltage (2.7–5.5V) versions of the dual and quad commodity op amps, LM358/324, which currently operate at 5–30V. The LMV321 is the single version.

The LMV321/358/324 are the most cost effective solutions for the applications where low voltage operation, space saving and low price are needed. They offer specifications that meet or exceed the familiar LM358/324. The LMV321/358/324 have rail-to-rail output swing capability and the input common-mode voltage range includes ground. They all exhibit excellent speed-power ratio, achieving 1MHz of bandwidth and 1V/μs of slew rate with low supply current.

The LMV321 is available in space saving SC70-5, which is approximately half the size of SOT23-5. The small package saves space on pc boards, and enables the design of small portable electronic devices. It also allows the designer to place the device closer to the signal source to reduce noise pickup and increase signal integrity.

The chips are built with National's advanced submicron silicon-gate BiCMOS process. The LMV321/358/324 have bipolar input and output stages for improved noise performance and higher output current drive.

Features

(For $V^+ = 5V$ and $V^- = 0V$, Typical Unless Otherwise Noted)

- Guaranteed 2.7V and 5V Performance
- No Crossover Distortion
- Space Saving Package SC70-5 2.0x2.1x1.0mm
- Industrial Temp. Range -40°C to +85°C
- Gain-Bandwidth Product 1MHz
- Low Supply Current
 - LMV321 130μA
 - LMV358 210μA
 - LMV324 410μA
- Rail-to-Rail Output Swing @ 10kΩ $V^+ - 10mV$
 $V^- + 65mV$
- V_{CM} -0.2V to $V^+ - 0.8V$

Applications

- Active Filters
- General Purpose Low Voltage Applications
- General Purpose Portable Devices

Gain and Phase vs. Capacitive Load

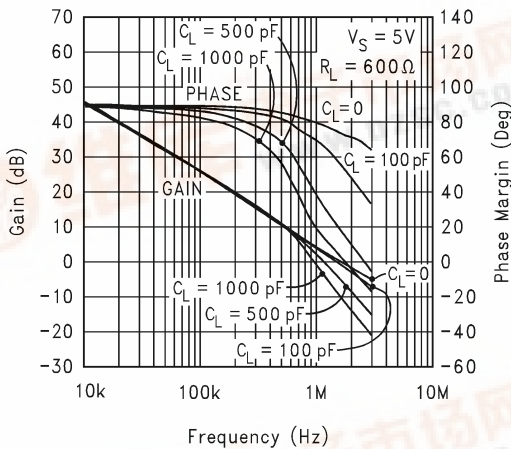

10006045

Output Voltage Swing vs. Supply Voltage

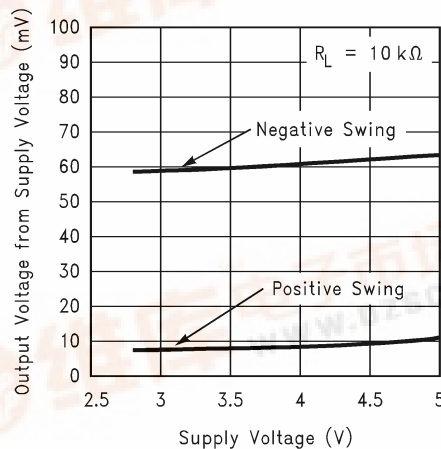

10006067

LMV321/LMV358/LMV324 Single/Dual/Quad General Purpose, Low Voltage, Rail-to-Rail Output Operational Amplifiers



Absolute Maximum Ratings (Note 1)

If Military/Aerospace specified devices are required, please contact the National Semiconductor Sales Office/ Distributors for availability and specifications.

ESD Tolerance (Note 2)	
Machine Model	100V
Human Body Model	
LMV358/324	2000V
LMV321	900V
Differential Input Voltage	± Supply Voltage
Supply Voltage (V ⁺ -V ⁻)	5.5V
Output Short Circuit to V ⁺	(Note 3)
Output Short Circuit to V ⁻	(Note 4)
Soldering Information	
Infrared or Convection (20 sec)	235°C

Storage Temp. Range	-65°C to 150°C
Junction Temperature(Note 5)	150°C

Operating Ratings (Note 1)

Supply Voltage	2.7V to 5.5V
Temperature Range	
LMV321, LMV358, LMV324	-40°C to +85°C
Thermal Resistance (θ _{JA})(Note 10)	
5-pin SC70-5	478°C/W
5-pin SOT23-5	265°C/W
8-Pin SOIC	190°C/W
8-Pin MSOP	235°C/W
14-Pin SOIC	145°C/W
14-Pin TSSOP	155°C/W

2.7V DC Electrical Characteristics

Unless otherwise specified, all limits guaranteed for T_J = 25°C, V⁺ = 2.7V, V⁻ = 0V, V_{CM} = 1.0V, V_O = V⁺/2 and R_L > 1MΩ.

Symbol	Parameter	Conditions	Typ (Note 6)	Limit (Note 7)	Units
V _{OS}	Input Offset Voltage		1.7	7	mV max
TCV _{OS}	Input Offset Voltage Average Drift		5		μV/°C
I _B	Input Bias Current		11	250	nA max
I _{OS}	Input Offset Current		5	50	nA max
CMRR	Common Mode Rejection Ratio	0V ≤ V _{CM} ≤ 1.7V	63	50	dB min
PSRR	Power Supply Rejection Ratio	2.7V ≤ V ⁺ ≤ 5V V _O = 1V	60	50	dB min
V _{CM}	Input Common-Mode Voltage Range	For CMRR ≥ 50dB	-0.2	0	V min
			1.9	1.7	V max
V _O	Output Swing	R _L = 10kΩ to 1.35V	V ⁺ -10	V ⁺ -100	mV min
			60	180	mV max
I _S	Supply Current	LMV321	80	170	μA max
		LMV358 Both amplifiers	140	340	μA max
		LMV324 All four amplifiers	260	680	μA max

2.7V AC Electrical Characteristics

Unless otherwise specified, all limits guaranteed for $T_J = 25^\circ\text{C}$, $V^+ = 2.7\text{V}$, $V^- = 0\text{V}$, $V_{\text{CM}} = 1.0\text{V}$, $V_O = V^+/2$ and $R_L > 1\text{M}\Omega$.

Symbol	Parameter	Conditions	Typ (Note 6)	Limit (Note 7)	Units
GBWP	Gain-Bandwidth Product	$C_L = 200\text{pF}$	1		MHz
Φ_m	Phase Margin		60		Deg
G_m	Gain Margin		10		dB
e_n	Input-Referred Voltage Noise	$f = 1\text{kHz}$	46		$\frac{\text{nV}}{\sqrt{\text{Hz}}}$
i_n	Input-Referred Current Noise	$f = 1\text{kHz}$	0.17		$\frac{\text{pA}}{\sqrt{\text{Hz}}}$

5V DC Electrical Characteristics

Unless otherwise specified, all limits guaranteed for $T_J = 25^\circ\text{C}$, $V^+ = 5\text{V}$, $V^- = 0\text{V}$, $V_{\text{CM}} = 2.0\text{V}$, $V_O = V^+/2$ and $R_L > 1\text{M}\Omega$.

Boldface limits apply at the temperature extremes.

Symbol	Parameter	Conditions	Typ (Note 6)	Limit (Note 7)	Units
V_{OS}	Input Offset Voltage		1.7	7 9	mV max
TCV_{OS}	Input Offset Voltage Average Drift		5		$\mu\text{V}/^\circ\text{C}$
I_B	Input Bias Current		15	250 500	nA max
I_{OS}	Input Offset Current		5	50 150	nA max
CMRR	Common Mode Rejection Ratio	$0\text{V} \leq V_{\text{CM}} \leq 4\text{V}$	65	50	dB min
PSRR	Power Supply Rejection Ratio	$2.7\text{V} \leq V^+ \leq 5\text{V}$ $V_O = 1\text{V}$ $V_{\text{CM}} = 1\text{V}$	60	50	dB min
V_{CM}	Input Common-Mode Voltage Range	For CMRR \geq 50dB	-0.2	0	V min
			4.2	4	V max
A_V	Large Signal Voltage Gain (Note 8)	$R_L = 2\text{k}\Omega$	100	15 10	V/mV min
V_O	Output Swing	$R_L = 2\text{k}\Omega$ to 2.5V	$V^+ - 40$	$V^+ - 300$ $V^+ - 400$	mV min
			120	300 400	mV max
		$R_L = 10\text{k}\Omega$ to 2.5V	$V^+ - 10$	$V^+ - 100$ $V^+ - 200$	mV min
			65	180 280	mV max
I_O	Output Short Circuit Current	Sourcing, $V_O = 0\text{V}$	60	5	m min
		Sinking, $V_O = 5\text{V}$	160	10	mA min
I_S	Supply Current	LMV321	130	250 350	μA max
		LMV358 Both amplifiers	210	440 615	μA max
		LMV324 All four amplifiers	410	830 1160	μA max

5V AC Electrical Characteristics

Unless otherwise specified, all limits guaranteed for $T_J = 25^\circ\text{C}$, $V^+ = 5\text{V}$, $V^- = 0\text{V}$, $V_{\text{CM}} = 2.0\text{V}$, $V_O = V^+/2$ and $R_L > 1\text{M}\Omega$.

Boldface limits apply at the temperature extremes.

Symbol	Parameter	Conditions	Typ (Note 6)	Limit (Note 7)	Units
SR	Slew Rate	(Note 9)	1		V/ μs
GBWP	Gain-Bandwidth Product	$C_L = 200\text{pF}$	1		MHz
Φ_m	Phase Margin		60		Deg
G_m	Gain Margin		10		dB
e_n	Input-Referred Voltage Noise	$f = 1\text{kHz}$	39		$\frac{\text{nV}}{\sqrt{\text{Hz}}}$
i_n	Input-Referred Current Noise	$f = 1\text{kHz}$	0.21		$\frac{\text{pA}}{\sqrt{\text{Hz}}}$

Note 1: Absolute Maximum Ratings indicate limits beyond which damage to the device may occur. Operating Ratings indicate conditions for which the device is intended to be functional, but specific performance is not guaranteed. For guaranteed specifications and the test conditions, see the Electrical Characteristics.

Note 2: Human body model, $1.5\text{k}\Omega$ in series with 100pF . Machine model, 0Ω in series with 200pF .

Note 3: Shorting output to V^+ will adversely affect reliability.

Note 4: Shorting output to V^- will adversely affect reliability.

Note 5: The maximum power dissipation is a function of $T_{\text{J(MAX)}}$, θ_{JA} , and T_{A} . The maximum allowable power dissipation at any ambient temperature is $P_D = (T_{\text{J(MAX)}} - T_{\text{A}}) / \theta_{\text{JA}}$. All numbers apply for packages soldered directly into a PC board.

Note 6: Typical values represent the most likely parametric norm.

Note 7: All limits are guaranteed by testing or statistical analysis.

Note 8: R_L is connected to V^- . The output voltage is $0.5\text{V} \leq V_O \leq 4.5\text{V}$.

Note 9: Connected as voltage follower with 3V step input. Number specified is the slower of the positive and negative slew rates.

Note 10: All numbers are typical, and apply for packages soldered directly onto a PC board in still air.

Typical Performance Characteristics

Unless otherwise specified, $V_S = +5V$, single supply,

$T_A = 25^\circ C$.

Supply Current vs. Supply Voltage (LMV321)

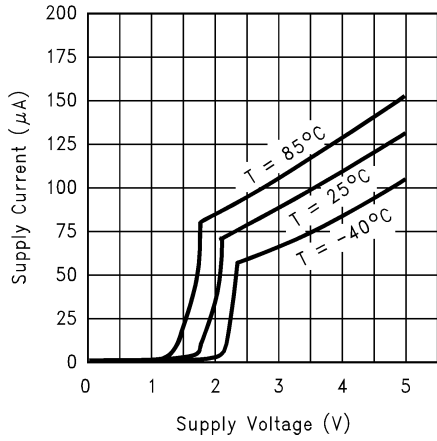

Input Current vs. Temperature

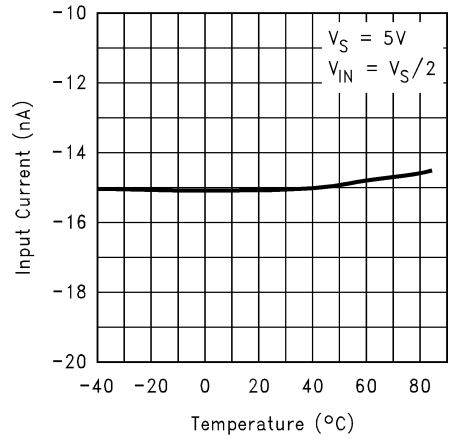

Sourcing Current vs. Output Voltage

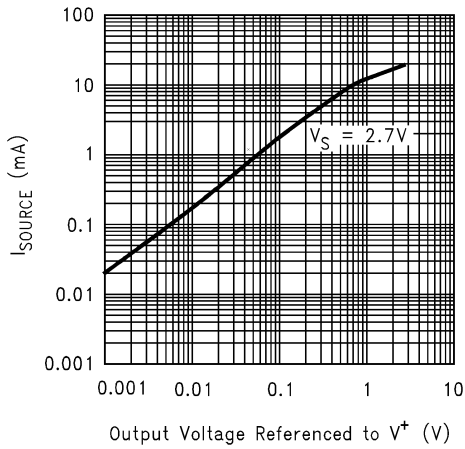

Sourcing Current vs. Output Voltage

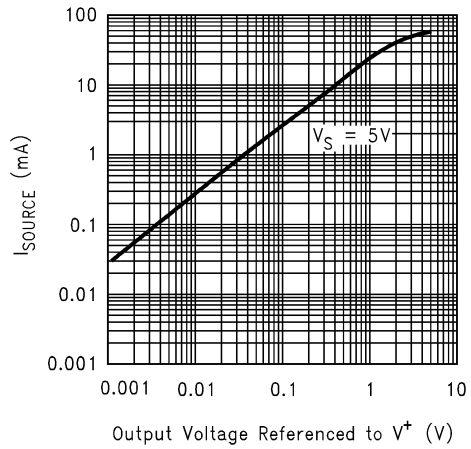

Sinking Current vs. Output Voltage

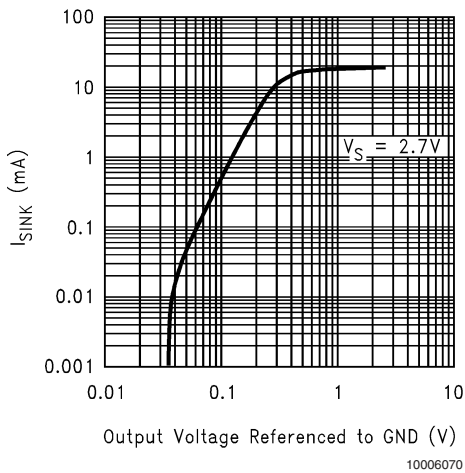

Sinking Current vs. Output Voltage

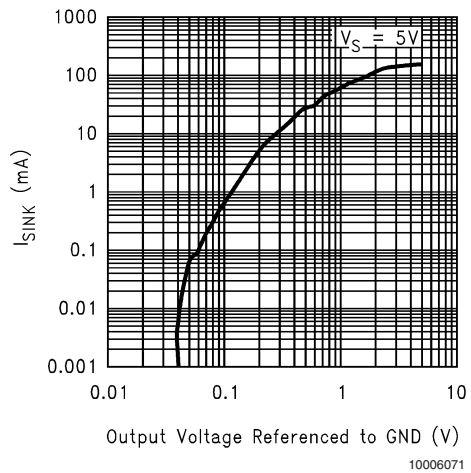

Typical Performance Characteristics Unless otherwise specified, $V_S = +5V$, single supply, $T_A = 25^\circ C$. (Continued)

Output Voltage Swing vs. Supply Voltage

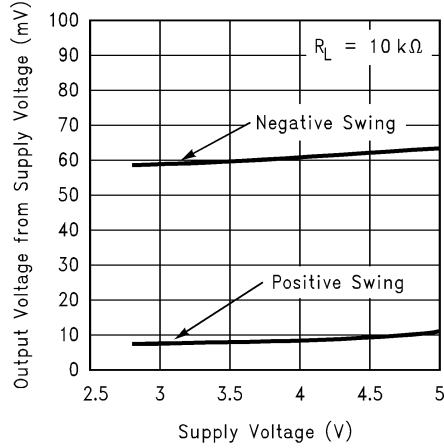

10006067

Input Voltage Noise vs. Frequency

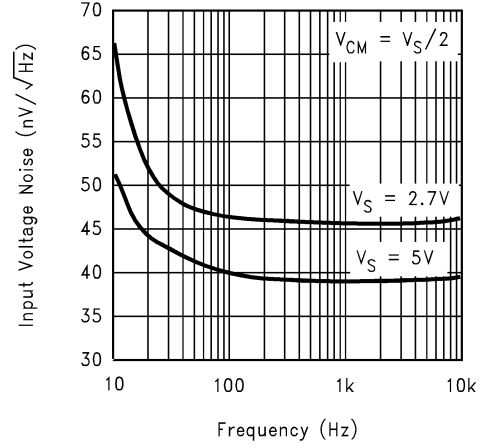

10006056

Input Current Noise vs. Frequency

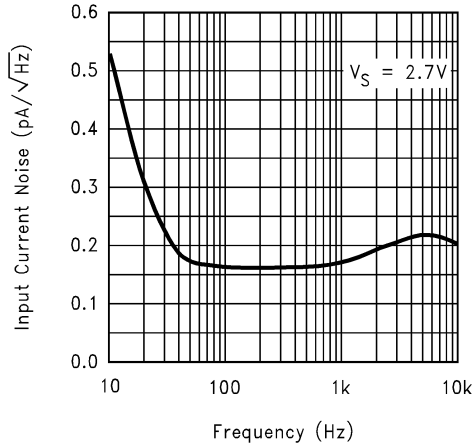

10006060

Input Current Noise vs. Frequency

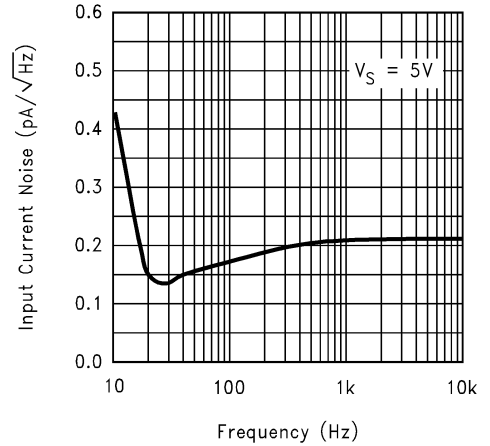

10006058

Crosstalk Rejection vs. Frequency

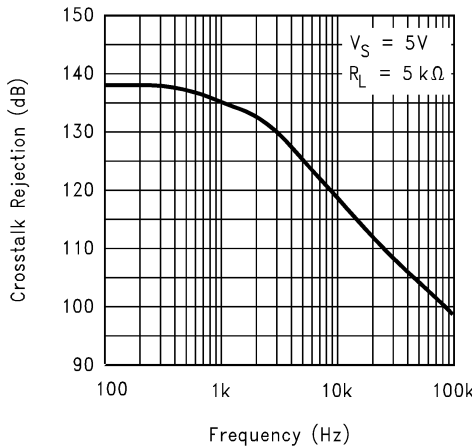

10006061

PSRR vs. Frequency

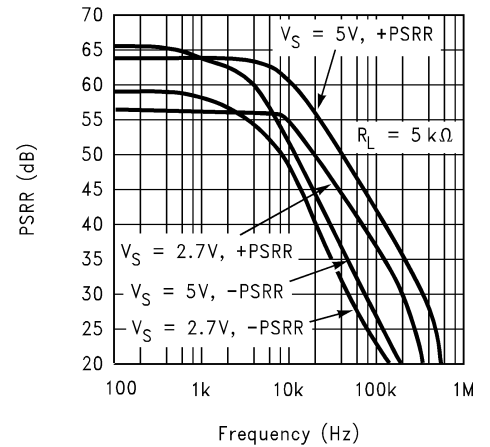

10006051

Typical Performance Characteristics Unless otherwise specified, $V_S = +5V$, single supply, $T_A = 25^\circ C$. (Continued)

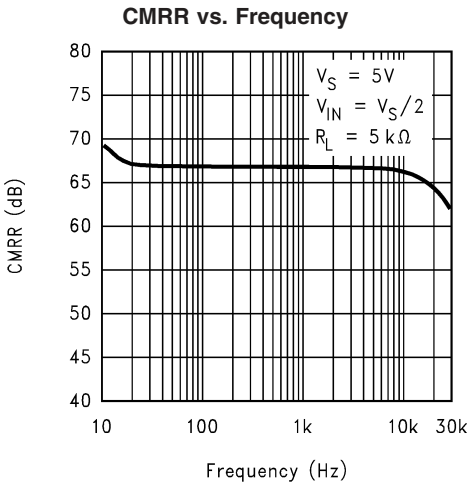

10006062

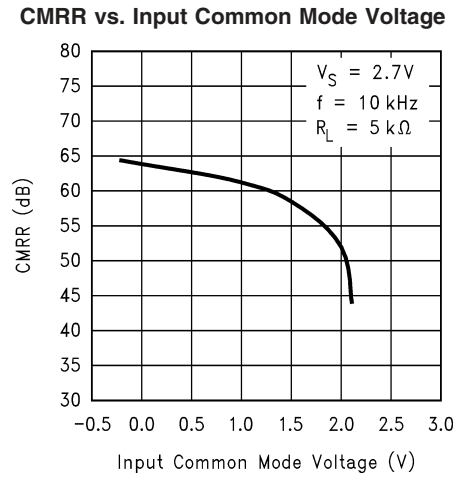

10006064

CMRR vs. Input Common Mode Voltage

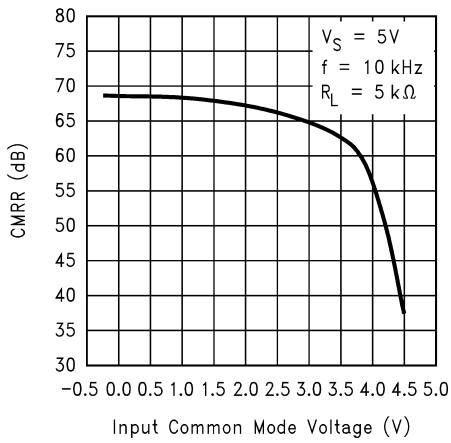

10006063

ΔV_{OS} vs. CMR

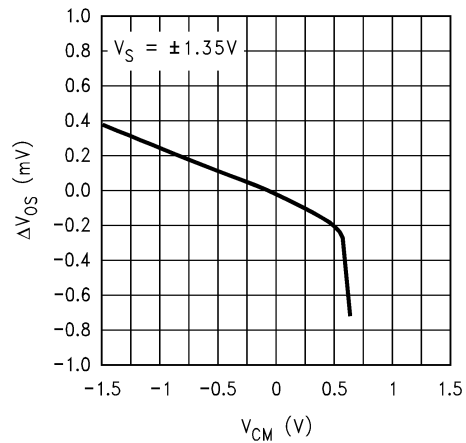

10006053

ΔV_{OS} vs. CMR

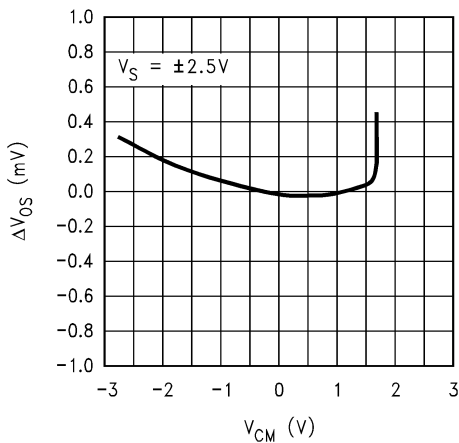

10006050

Input Voltage vs. Output Voltage

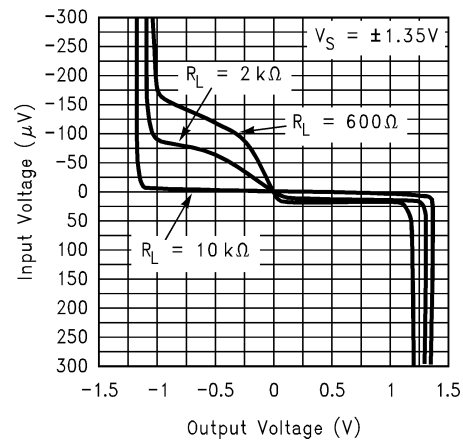

10006054

Typical Performance Characteristics Unless otherwise specified, $V_S = +5V$, single supply, $T_A = 25^\circ C$. (Continued)

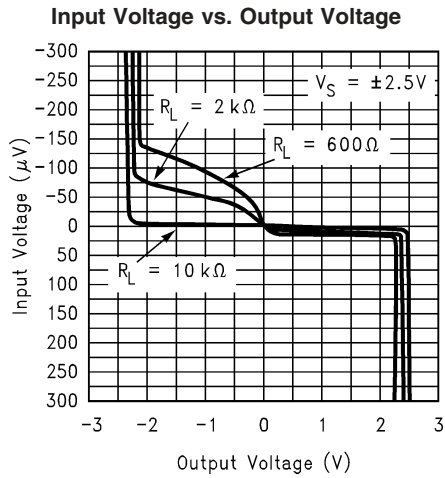

10006052

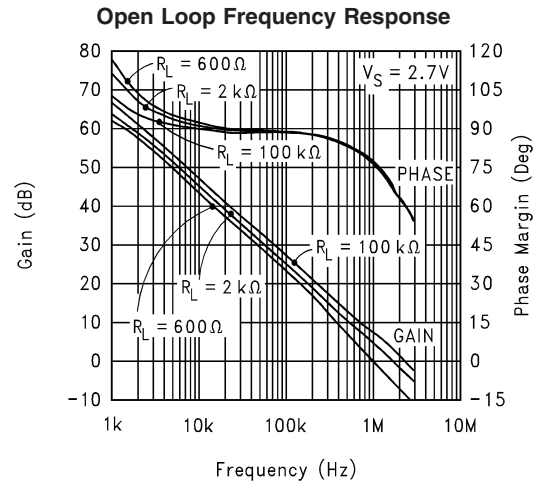

10006042

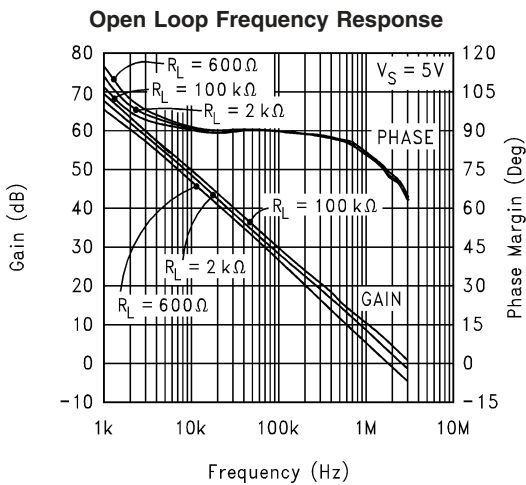

10006041

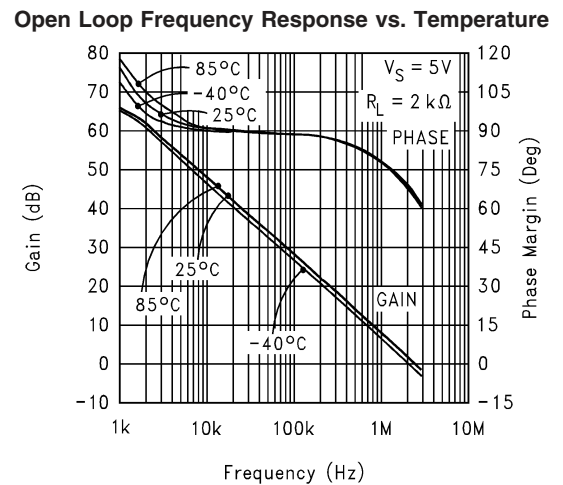

10006043

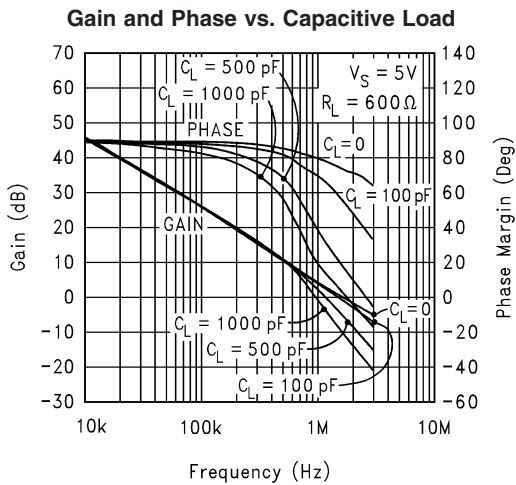

10006045

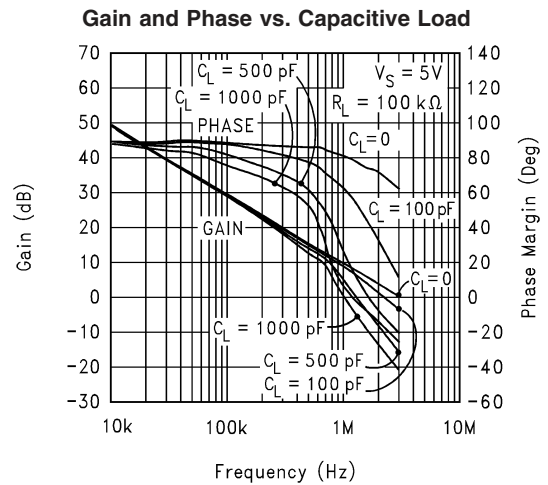

10006044

Typical Performance Characteristics Unless otherwise specified, $V_S = +5V$, single supply, $T_A = 25^\circ C$. (Continued)

Slew Rate vs. Supply Voltage

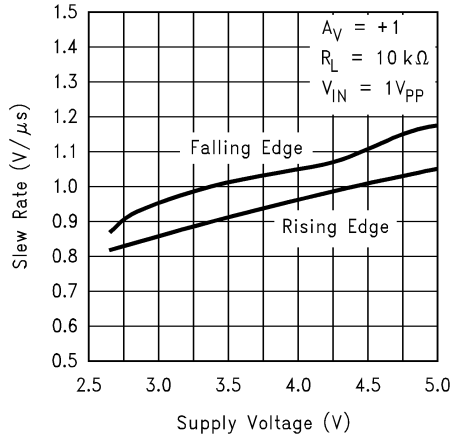

10006057

Non-Inverting Large Signal Pulse Response

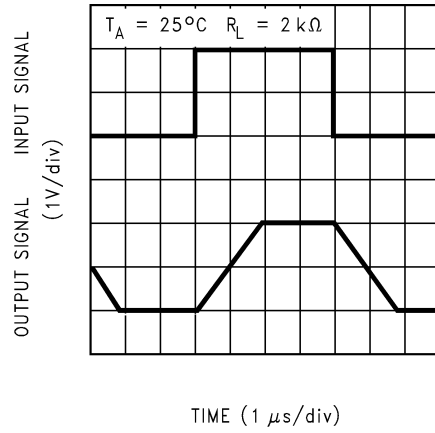

10006088

Non-Inverting Large Signal Pulse Response

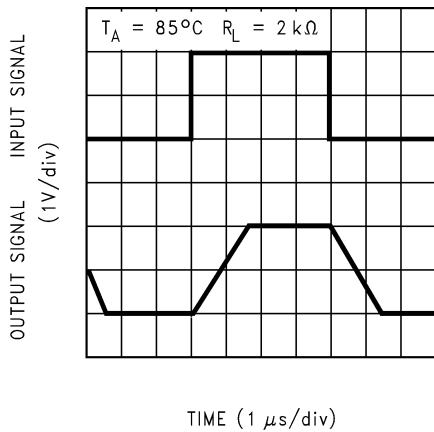

100060A1

Non-Inverting Large Signal Pulse Response

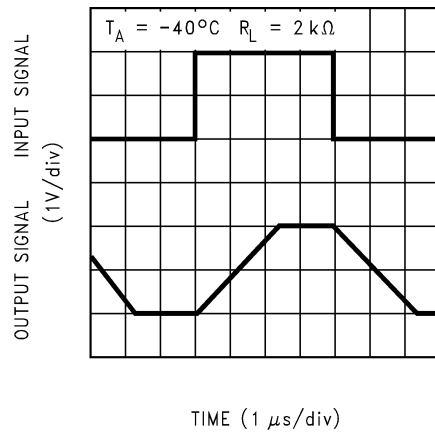

100060A0

Non-Inverting Small Signal Pulse Response

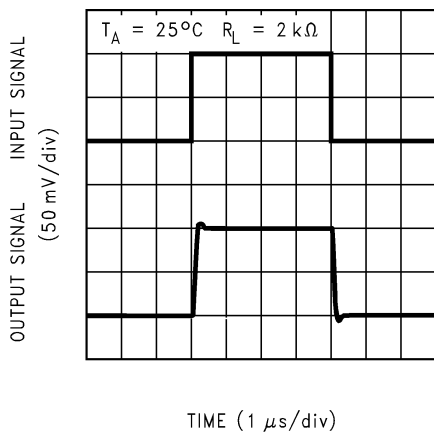

10006089

Non-Inverting Small Signal Pulse Response

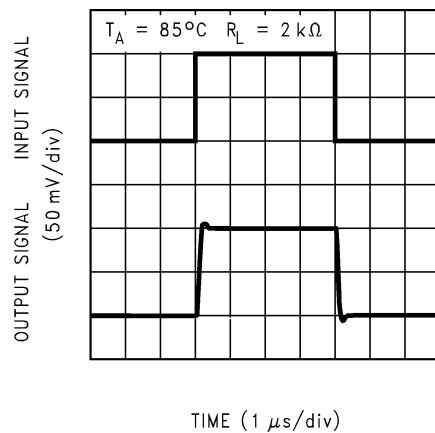

100060A2

Typical Performance Characteristics Unless otherwise specified, $V_S = +5V$, single supply, $T_A = 25^\circ C$. (Continued)

Non-Inverting Small Signal Pulse Response

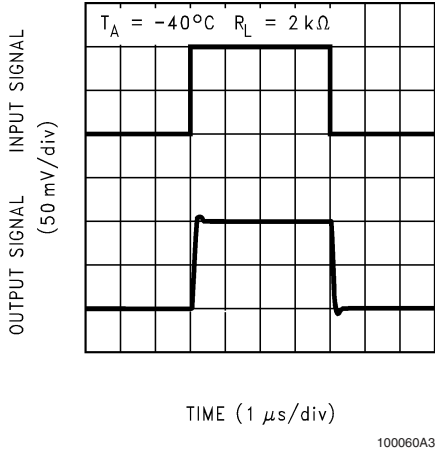

Inverting Large Signal Pulse Response

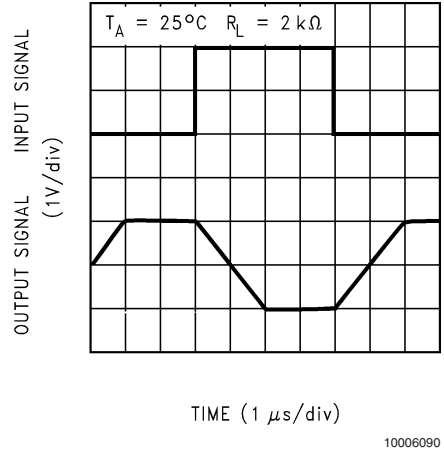

Inverting Large Signal Pulse Response

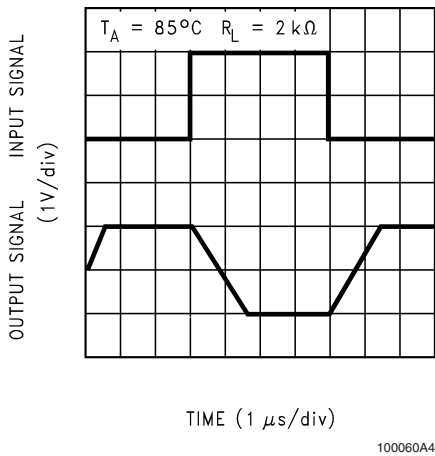

Inverting Large Signal Pulse Response

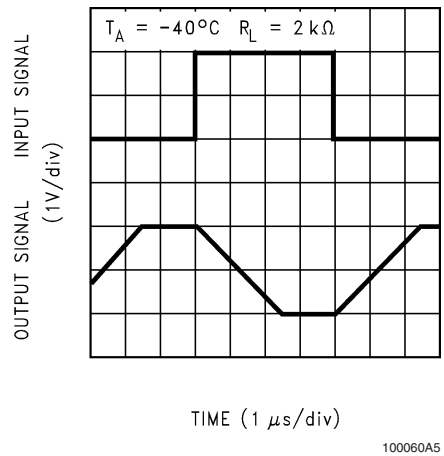

Inverting Small Signal Pulse Response

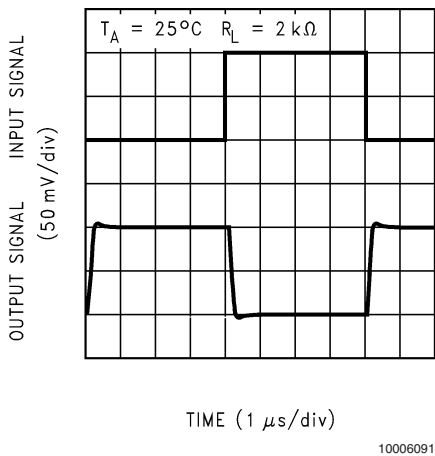

Inverting Small Signal Pulse Response

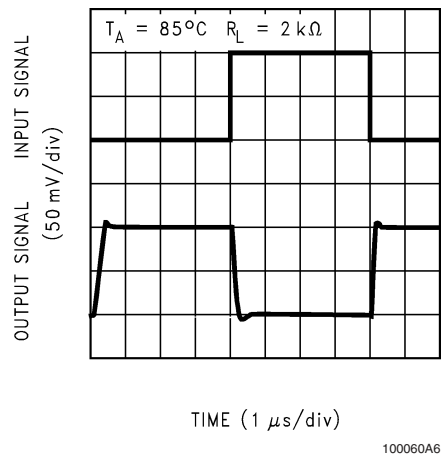

Typical Performance Characteristics Unless otherwise specified, $V_S = +5V$, single supply, $T_A = 25^\circ C$. (Continued)

Inverting Small Signal Pulse Response

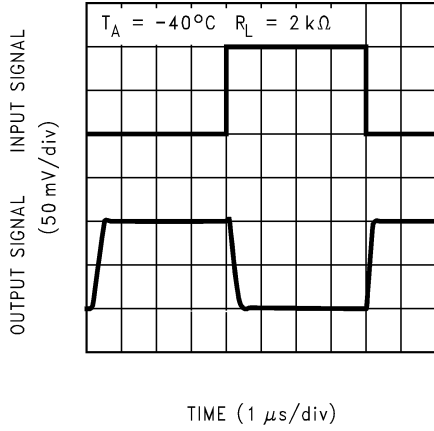

100060A7

Stability vs. Capacitive Load

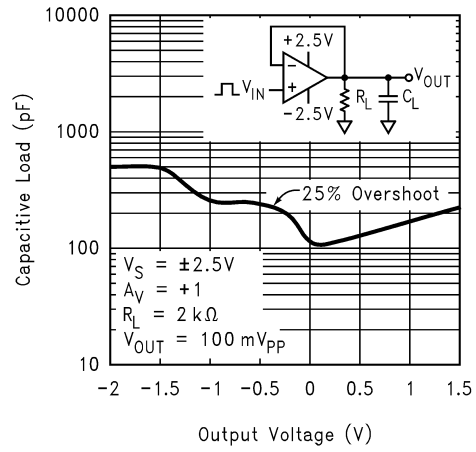

10006046

Stability vs. Capacitive Load

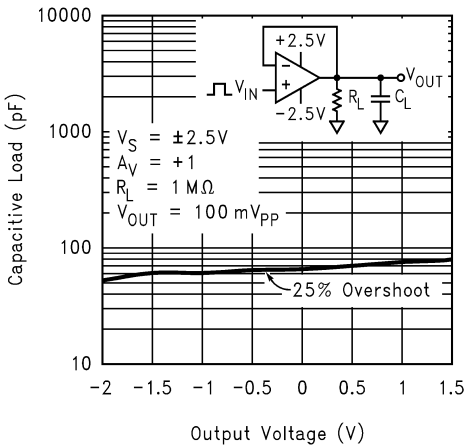

10006047

Stability vs. Capacitive Load

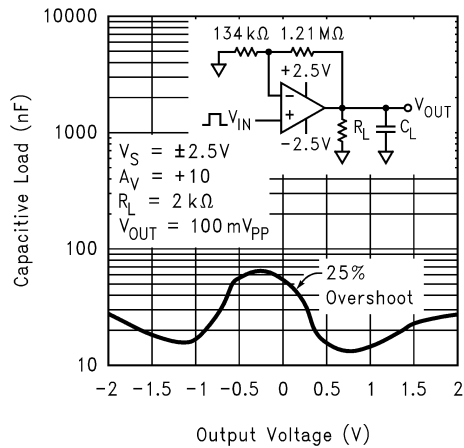

10006049

Stability vs. Capacitive Load

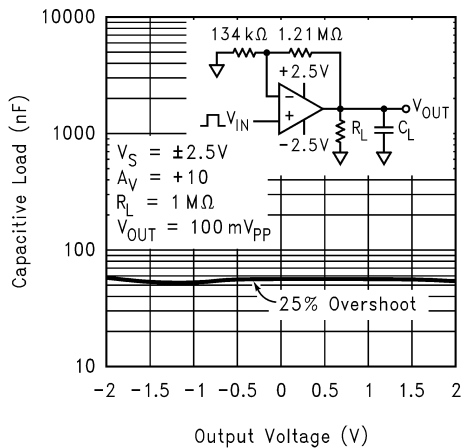

10006048

THD vs. Frequency

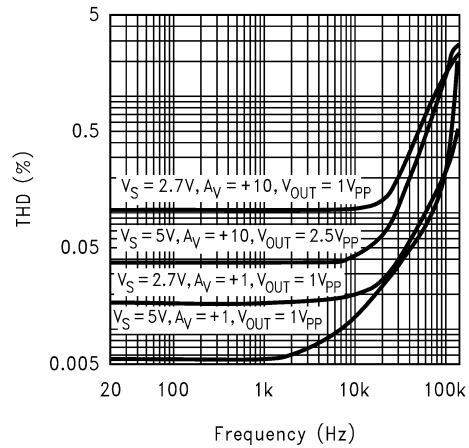

10006059

Typical Performance Characteristics Unless otherwise specified, $V_S = +5V$, single supply, $T_A = 25^\circ C$. (Continued)

Open Loop Output Impedance vs. Frequency

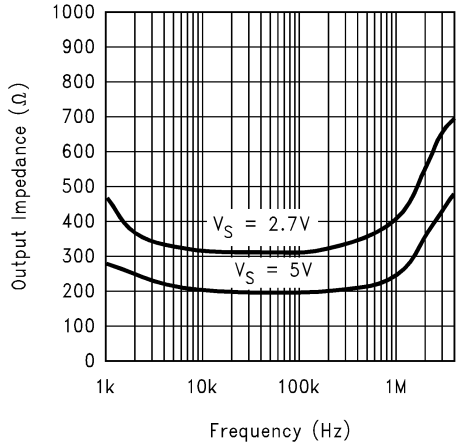

10006055

Short Circuit Current vs. Temperature (Sinking)

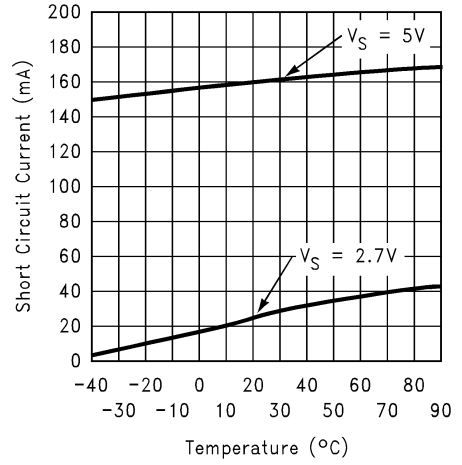

10006065

Short Circuit Current vs. Temperature (Sourcing)

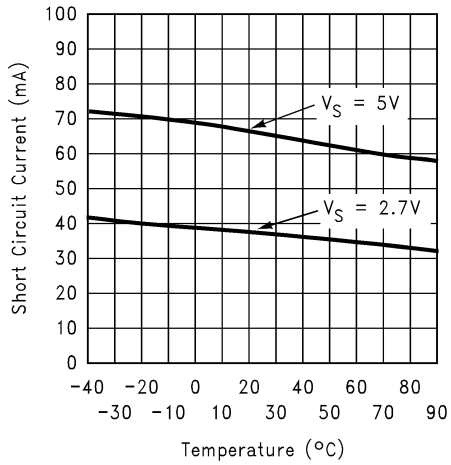

10006066

Application Notes

1.0 BENEFITS OF THE LMV321/358/324

Size: The small footprints of the LMV321/358/324 packages save space on printed circuit boards, and enable the design of smaller electronic products, such as cellular phones, pagers, or other portable systems. The low profile of the LMV321/358/324 make them possible to use in PCMCIA type III cards.

Signal Integrity

Signals can pick up noise between the signal source and the amplifier. By using a physically smaller amplifier package, the LMV321/358/324 can be placed closer to the signal source, reducing noise pickup and increasing signal integrity.

Simplified Board Layout

These products help you to avoid using long pc traces in your pc board layout. This means that no additional components, such as capacitors and resistors, are needed to filter out the unwanted signals due to the interference between the long pc traces.

Low Supply Current

These devices will help you to maximize battery life. They are ideal for battery powered systems.

Low Supply Voltage

National provides guaranteed performance at 2.7V and 5V. These guarantees ensure operation throughout the battery lifetime.

Rail-to-Rail Output

Rail-to-rail output swing provides maximum possible dynamic range at the output. This is particularly important when operating on low supply voltages.

Input Includes Ground

Allows direct sensing near GND in single supply operation. The differential input voltage may be larger than V^+ without damaging the device. Protection should be provided to prevent the input voltages from going negative more than $-0.3V$ (at $25^\circ C$). An input clamp diode with a resistor to the IC input terminal can be used.

Ease Of Use & Crossover Distortion

The LMV321/358/324 offer specifications similar to the familiar LM324. In addition, the new LMV321/358/324 effectively eliminate the output crossover distortion. The scope photos in *Figure 1* and *Figure 2* compare the output swing of the LMV324 and the LM324 in a voltage follower configuration, with $V_S = \pm 2.5V$ and $R_L (= 2k\Omega)$ connected to GND. It is apparent that the crossover distortion has been eliminated in the new LMV324.

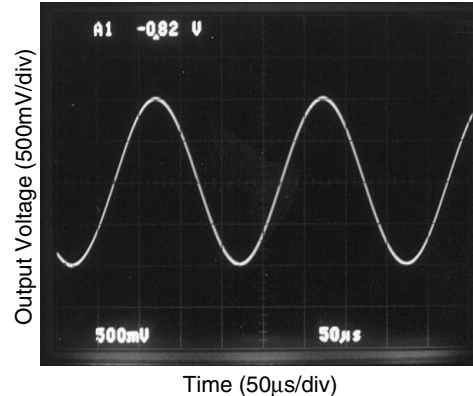

FIGURE 1. Output Swing of LMV324

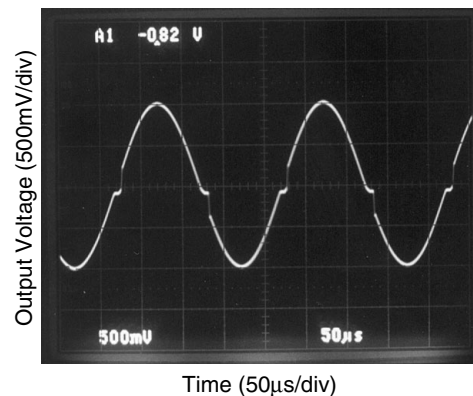

FIGURE 2. Output Swing of LM324

2.0 CAPACITIVE LOAD TOLERANCE

The LMV321/358/324 can directly drive 200pF in unity-gain without oscillation. The unity-gain follower is the most sensitive configuration to capacitive loading. Direct capacitive loading reduces the phase margin of amplifiers. The combination of the amplifier's output impedance and the capacitive load induces phase lag. This results in either an underdamped pulse response or oscillation. To drive a heavier capacitive load, circuit in *Figure 3* can be used.

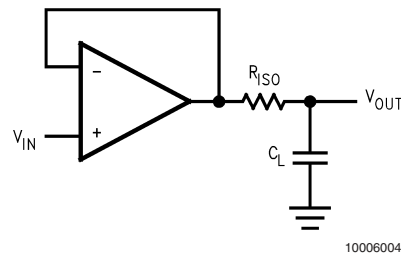

FIGURE 3. Indirectly Driving A Capacitive Load Using Resistive Isolation

Application Notes (Continued)

In *Figure 3*, the isolation resistor R_{ISO} and the load capacitor C_L form a pole to increase stability by adding more phase margin to the overall system. The desired performance depends on the value of R_{ISO} . The bigger the R_{ISO} resistor value, the more stable V_{OUT} will be. *Figure 4* is an output waveform of *Figure 3* using 620Ω for R_{ISO} and $510pF$ for C_L .

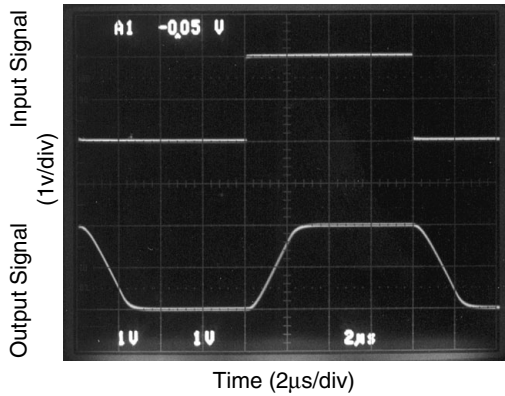

FIGURE 4. Pulse Response of the LMV324 Circuit in Figure 3

The circuit in *Figure 5* is an improvement to the one in *Figure 3* because it provides DC accuracy as well as AC stability. If there were a load resistor in *Figure 3*, the output would be voltage divided by R_{ISO} and the load resistor. Instead, in *Figure 5*, R_F provides the DC accuracy by using feed-forward techniques to connect V_{IN} to R_L . Caution is needed in choosing the value of R_F due to the input bias current of the LMV321/358/324. C_F and R_{ISO} serve to counteract the loss of phase margin by feeding the high frequency component of the output signal back to the amplifier's inverting input, thereby preserving phase margin in the overall feedback loop. Increased capacitive drive is possible by increasing the value of C_F . This in turn will slow down the pulse response.

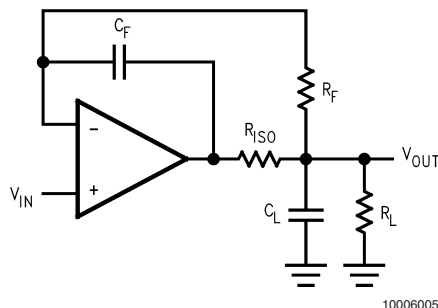

FIGURE 5. Indirectly Driving A Capacitive Load with DC Accuracy

3.0 INPUT BIAS CURRENT CANCELLATION

The LMV321/358/324 family has a bipolar input stage. The typical input bias current of LMV321/358/324 is $15nA$ with $5V$ supply. Thus a $100k\Omega$ input resistor will cause $1.5mV$ of error voltage. By balancing the resistor values at both inverting and non-inverting inputs, the error caused by the amplifier's

input bias current will be reduced. The circuit in *Figure 6* shows how to cancel the error caused by input bias current.

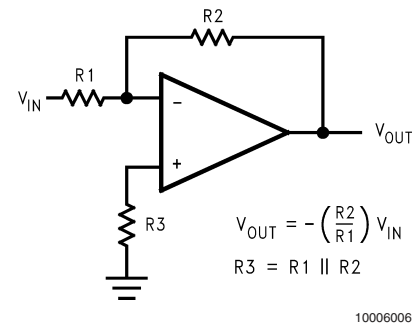
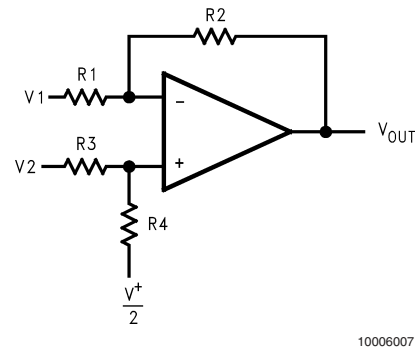

FIGURE 6. Cancelling the Error Caused by Input Bias Current

4.0 TYPICAL SINGLE-SUPPLY APPLICATION CIRCUITS

4.1 Difference Amplifier

The difference amplifier allows the subtraction of two voltages or, as a special case, the cancellation of a signal common to two inputs. It is useful as a computational amplifier, in making a differential to single-ended conversion or in rejecting a common mode signal.



$$V_{OUT} = \left(\frac{R1 + R2}{R3 + R4}\right) \frac{R4}{R1} V_2 - \frac{R2}{R1} V_1 + \left(\frac{R1 + R2}{R3 + R4}\right) \frac{R3}{R1} \cdot \frac{V^+}{2}$$

for $R1 = R3$ and $R2 = R4$

$$V_{OUT} = \frac{R2}{R1} (V_2 - V_1) + \frac{V^+}{2}$$

FIGURE 7. Difference Amplifier

4.2 Instrumentation Circuits

The input impedance of the previous difference amplifier is set by the resistors R_1 , R_2 , R_3 , and R_4 . To eliminate the problems of low input impedance, one way is to use a voltage follower ahead of each input as shown in the following two instrumentation amplifiers.

Application Notes (Continued)

4.2.1 Three-Op-Amp Instrumentation Amplifier

The quad LMV324 can be used to build a three-op-amp instrumentation amplifier as shown in *Figure 8*.

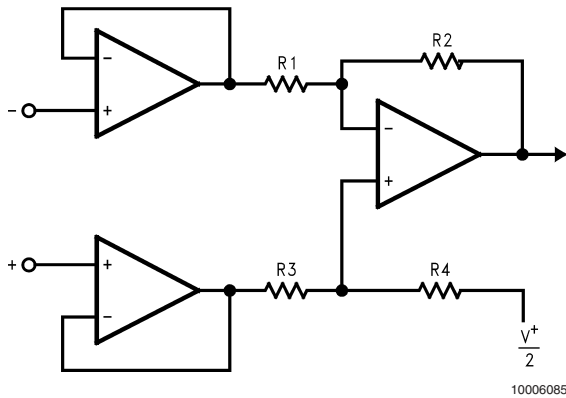
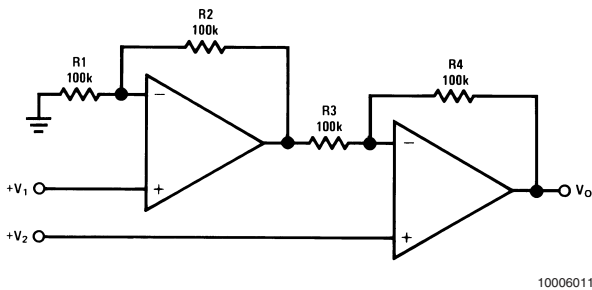

FIGURE 8. Three-op-amp Instrumentation Amplifier

The first stage of this instrumentation amplifier is a differential-input, differential-output amplifier, with two voltage followers. These two voltage followers assure that the input impedance is over 100 MΩ. The gain of this instrumentation amplifier is set by the ratio of R₂/R₁. R₃ should equal R₁, and R₄ equal R₂. Matching of R₃ to R₁ and R₄ to R₂ affects the CMRR. For good CMRR over temperature, low drift resistors should be used. Making R₄ slightly smaller than R₂ and adding a trim pot equal to twice the difference between R₂ and R₄ will allow the CMRR to be adjusted for optimum.

4.2.2 Two-op-amp Instrumentation Amplifier

A two-op-amp instrumentation amplifier can also be used to make a high-input-impedance dc differential amplifier (*Figure 9*). As in the three-op-amp circuit, this instrumentation amplifier requires precise resistor matching for good CMRR. R₄ should equal to R₁ and R₃ should equal R₂.



$$V_o = \left(1 + \frac{R_4}{R_3}\right)(V_2 - V_1), \text{ where } R_1 = R_4 \text{ and } R_2 = R_3$$

$$\text{As shown: } V_o = 2(V_2 - V_1)$$

FIGURE 9. Two-Op-amp Instrumentation Amplifier

4.3 Single-Supply Inverting Amplifier

There may be cases where the input signal going into the amplifier is negative. Because the amplifier is operating in single supply voltage, a voltage divider using R₃ and R₄ is implemented to bias the amplifier so the input signal is within the input common-mode voltage range of the amplifier. The capacitor C₁ is placed between the inverting input and resistor R₁ to block the DC signal going into the AC signal source, V_{IN}. The values of R₁ and C₁ affect the cutoff frequency, $f_c = 1/2\pi R_1 C_1$.

As a result, the output signal is centered around mid-supply (if the voltage divider provides V⁺/2 at the non-inverting input). The output can swing to both rails, maximizing the signal-to-noise ratio in a low voltage system.

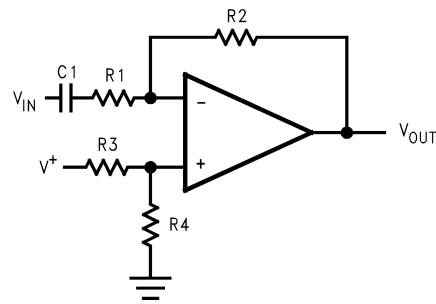

$$V_{OUT} = -\frac{R_2}{R_1} V_{IN}$$

FIGURE 10. Single-Supply Inverting Amplifier

4.4 ACTIVE FILTER

4.4.1 Simple Low-Pass Active Filter

The simple low-pass filter is shown in *Figure 11*. Its low-frequency gain ($\omega \rightarrow 0$) is defined by $-R_3/R_1$. This allows low-frequency gains other than unity to be obtained. The filter has a -20dB/decade roll-off after its corner frequency f_c . R₂ should be chosen equal to the parallel combination of R₁ and R₃ to minimize errors due to bias current. The frequency response of the filter is shown in *Figure 12*.

Application Notes (Continued)

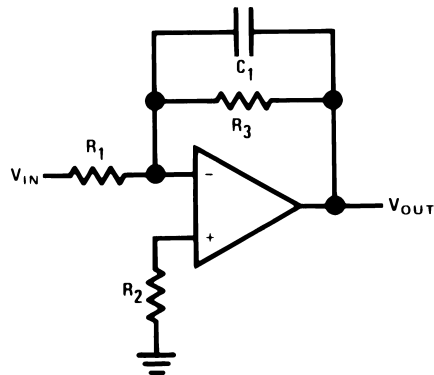

10006014

$$A_L = -\frac{R_3}{R_1}$$

$$f_c = \frac{1}{2\pi R_3 C_1}$$

$$R_2 = R_1 \parallel R_3$$

10006037

FIGURE 11. Simple Low-Pass Active Filter

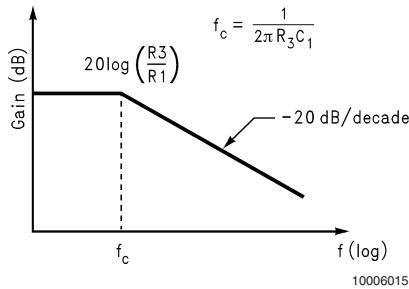

10006015

FIGURE 12. Frequency Response of Simple Low-Pass Active Filter in Figure 11

Note that the single-op-amp active filters are used in to the applications that require low quality factor, $Q (\leq 10)$, low frequency (≤ 5 kHz), and low gain (≤ 10), or a small value for the product of gain times $Q (\leq 100)$. The op amp should have an open loop voltage gain at the highest frequency of interest at least 50 times larger than the gain of the filter at this frequency. In addition, the selected op amp should have a slew rate that meets the following requirement:

$$\text{Slew Rate} \geq 0.5 \times (\omega_H V_{OPP}) \times 10^{-6} \text{ V}/\mu\text{sec}$$

where ω_H is the highest frequency of interest, and V_{OPP} is the output peak-to-peak voltage.

4.4.2 Sallen-Key 2nd-Order Active Low-Pass Filter

The Sallen-Key 2nd-order active low-pass filter is illustrated in Figure 13. The dc gain of the filter is expressed as

$$A_{LP} = \frac{R_3}{R_4} + 1 \tag{1}$$

Its transfer function is

$$\frac{V_{OUT}}{V_{IN}}(s) = \frac{\frac{1}{C_1 C_2 R_1 R_2} A_{LP}}{s^2 + s \left(\frac{1}{C_1 R_1} + \frac{1}{C_1 R_2} + \frac{1}{C_2 R_2} - \frac{A_{LP}}{C_2 R_2} \right) + \frac{1}{C_1 C_2 R_1 R_2}} \tag{2}$$

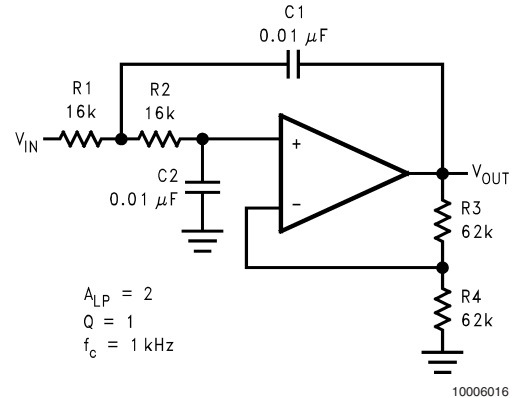

10006016

FIGURE 13. Sallen-Key 2nd-Order Active Low-Pass Filter

The following paragraphs explain how to select values for R_1 , R_2 , R_3 , R_4 , C_1 , and C_2 for given filter requirements, such as A_{LP} , Q , and f_c .

The standard form for a 2nd-order low pass filter is

$$\frac{V_{OUT}}{V_{IN}}(s) = \frac{A_{LP} \omega_c^2}{s^2 + \left(\frac{\omega_c}{Q} \right) s + \omega_c^2} \tag{3}$$

where

Q : Pole Quality Factor

ω_c : Corner Frequency

Comparison between the Equation (2) and Equation (3) yields

$$\omega_c^2 = \frac{1}{C_1 C_2 R_1 R_2} \tag{4}$$

$$\frac{\omega_c}{Q} = \frac{1}{C_1 R_1} + \frac{1}{C_1 R_2} + \frac{1}{C_2 R_2} - \frac{A_{LP}}{C_2 R_2} \tag{5}$$

To reduce the required calculations in filter design, it is convenient to introduce normalization into the components and design parameters. To normalize, let $\omega_c = \omega_n = 1$ rad/s, and $C_1 = C_2 = C_n = 1$ F, and substitute these values into Equation (4) and Equation (5). From Equation (4), we obtain

$$R_1 = \frac{1}{R_2} \tag{6}$$

From Equation (5), we obtain

$$R_2 = \frac{1 \pm \sqrt{1 - 4Q^2(2 - A_{LP})}}{2Q} \tag{7}$$

Application Notes (Continued)

For minimum dc offset, $V^+ = V^-$, the resistor values at both inverting and non-inverting inputs should be equal, which means

$$R_1 + R_2 = \frac{R_3 R_4}{R_3 + R_4} \quad (8)$$

From Equation (1) and Equation (8), we obtain

$$R_3 = (R_1 + R_2) A_{LP} \quad (9)$$

$$R_4 = \left(\frac{A_{LP}}{A_{LP} - 1} \right) (R_1 + R_2) \quad (10)$$

The values of C_1 and C_2 are normally close to or equal to

$$C = \frac{10}{f_c} \mu F$$

As a design example:

Require: $A_{LP} = 2$, $Q = 1$, $f_c = 1 \text{ KHz}$

Start by selecting C_1 and C_2 . Choose a standard value that is close to

$$C = \frac{10}{f_c} \mu F$$

$$C_1 = C_2 = \frac{10}{1 \times 10^3} \mu F = 0.01 \mu F$$

From Equations (6), (7), (9), (10),

$$R_1 = 1\Omega$$

$$R_2 = 1\Omega$$

$$R_3 = 4\Omega$$

$$R_4 = 4\Omega$$

The above resistor values are normalized values with $\omega_n = 1 \text{ rad/s}$ and $C_1 = C_2 = C_n = 1 \text{ F}$. To scale the normalized cut-off frequency and resistances to the real values, two scaling factors are introduced, frequency scaling factor (k_f) and impedance scaling factor (k_m).

$$k_f = \frac{\omega_c}{\omega_n} = \frac{2\pi \times 1 \times 10^3}{1} = 2\pi \times 10^3$$

$$k_m k_f = \frac{C_n}{C_1}$$

$$k_m = 1.59 \times 10^4$$

Scaled values:

$$R_2 = R_1 = 15.9 \text{ k}\Omega$$

$$R_3 = R_4 = 63.6 \text{ k}\Omega$$

$$C_1 = C_2 = 0.01 \mu F$$

An adjustment to the scaling may be made in order to have realistic values for resistors and capacitors. The actual value used for each component is shown in the circuit.

4.4.3 2nd-order High Pass Filter

A 2nd-order high pass filter can be built by simply interchanging those frequency selective components (R_1, R_2, C_1, C_2) in the Sallen-Key 2nd-order active low pass filter. As shown in Figure 14, resistors become capacitors, and capacitors become resistors. The resulted high pass filter has the same corner frequency and the same maximum gain as the previous 2nd-order low pass filter if the same components are chosen.

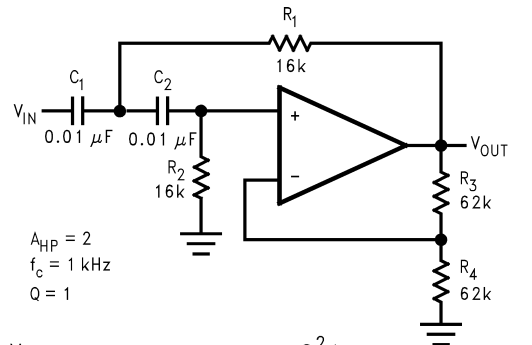

$$A_{HP} = 2$$

$$f_c = 1 \text{ kHz}$$

$$Q = 1$$

$$\frac{V_{OUT}}{V_{IN}}(S) = \frac{S^2 A_{HP}}{S^2 + S \left(\frac{1}{C_1 R_2} + \frac{1}{C_2 R_2} + \frac{(1 - A_{HP})}{C_1 R_1} \right) + \frac{1}{C_1 C_2 R_1 R_2}}$$

Where $A_{HP} = 1 + \frac{R_3}{R_4}$

10006083

FIGURE 14. Sallen-Key 2nd-Order Active High-Pass Filter

4.4.4 State Variable Filter

A state variable filter requires three op amps. One convenient way to build state variable filters is with a quad op amp, such as the LMV324 (Figure 15).

This circuit can simultaneously represent a low-pass filter, high-pass filter, and bandpass filter at three different outputs. The equations for these functions are listed below. It is also called "Bi-Quad" active filter as it can produce a transfer function which is quadratic in both numerator and denominator.

Application Notes (Continued)

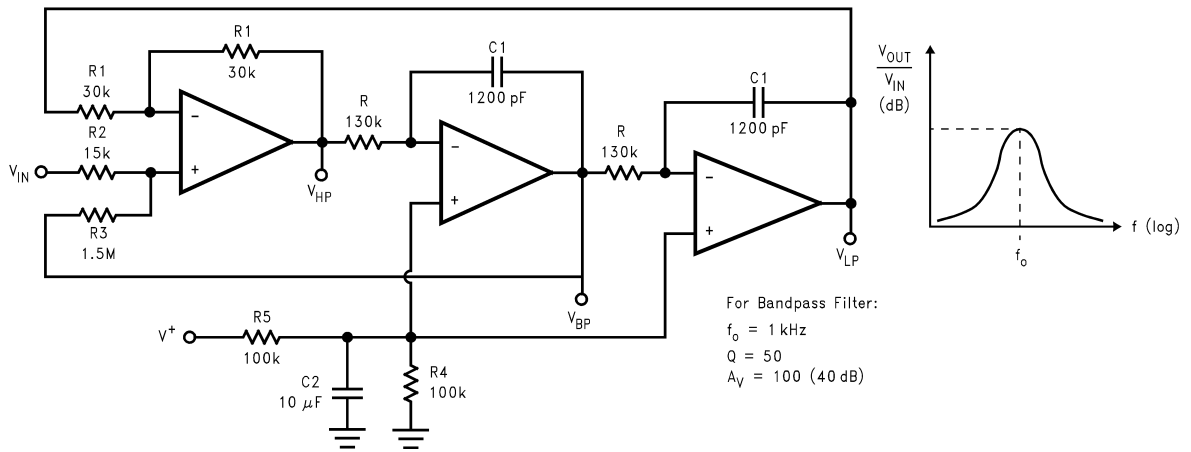

10006039

FIGURE 15. State Variable Active Filter

$$V_{LP} = \left(\frac{2R_3}{R_2 + R_3} \right) \frac{\frac{1}{R^2 C^2}}{S^2 + \frac{1}{\left(\frac{R_2 + R_3}{2R_2} \right) RC} S + \frac{1}{R^2 C^2}} V_{IN}$$

$$V_{HP} = \left(\frac{2R_3}{R_2 + R_3} \right) \frac{S^2}{S^2 + \frac{1}{\left(\frac{R_2 + R_3}{2R_2} \right) RC} S + \frac{1}{R^2 C^2}} V_{IN}$$

$$V_{BP} = \left(\frac{2R_3}{R_2 + R_3} \right) \frac{\left(\frac{1}{RC} \right) S}{S^2 + \frac{1}{\left(\frac{R_2 + R_3}{2R_2} \right) RC} S + \frac{1}{R^2 C^2}} V_{IN}$$

where for all three filters,

$$Q = \frac{R_2 + R_3}{2R_2} \tag{11}$$

$$\omega_0 = \frac{1}{RC} \quad (\text{resonant frequency}) \tag{12}$$

A design example for a bandpass filter is shown below: Assume the system design requires a bandpass filter with $f_0 = 1 \text{ kHz}$ and $Q = 50$. What needs to be calculated are capacitor and resistor values.

First choose convenient values for C_1 , R_1 and R_2 :

$$C_1 = 1200 \text{ pF}$$

$$2R_2 = R_1 = 30 \text{ k}\Omega$$

Then from Equation (11),

$$R_3 = R_2 (2Q - 1)$$

$$R_3 = 15 \text{ k}\Omega \times (2 \times 50 - 1) = 1.5 \text{ M}\Omega$$

From Equation (12),

$$R = \frac{1}{\omega_0 C_1}$$

$$R = \frac{1}{(2\pi \times 10^3)(1.2 \times 10^{-9})} = 132.7 \text{ k}\Omega$$

From the above calculated values, the midband gain is $H_0 = R_3/R_2 = 100 \text{ (40dB)}$. The nearest 5% standard values have been added to Figure 15.

4.5 PULSE GENERATORS AND OSCILLATORS

A pulse generator is shown in Figure 16. Two diodes have been used to separate the charge and discharge paths to capacitor C.

Application Notes (Continued)

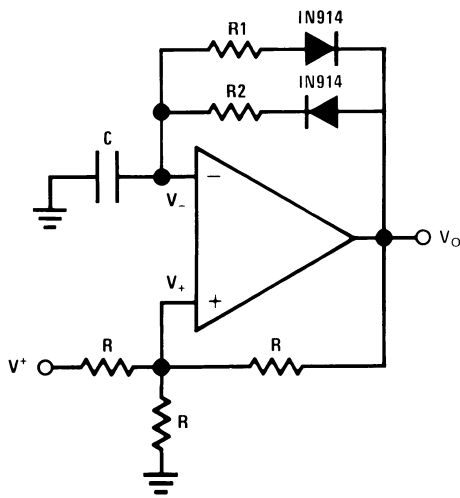

10006081

FIGURE 16. Pulse Generator

When the output voltage V_O is first at its high, V_{OH} , the capacitor C is charged toward V_{OH} through R_2 . The voltage across C rises exponentially with a time constant $\tau = R_2C$, and this voltage is applied to the inverting input of the op amp. Meanwhile, the voltage at the non-inverting input is set at the positive threshold voltage (V_{TH+}) of the generator. The capacitor voltage continually increases until it reaches V_{TH+} , at which point the output of the generator will switch to its low, V_{OL} ($= 0V$ in this case). The voltage at the non-inverting input is switched to the negative threshold voltage (V_{TH-}) of the generator. The capacitor then starts to discharge toward V_{OL} exponentially through R_1 , with a time constant $\tau = R_1C$. When the capacitor voltage reaches V_{TH-} , the output of the pulse generator switches to V_{OH} . The capacitor starts to charge, and the cycle repeats itself.

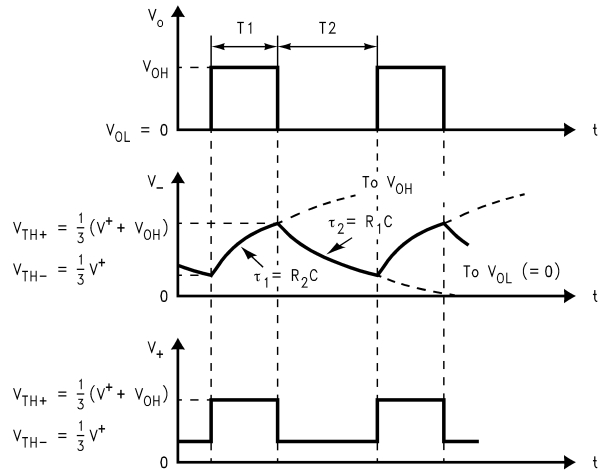

$$T_1 = R_2C \ln \frac{3V_{OH} - V_{OL} - V^+}{2V_{OH} - V^+} \quad \text{and} \quad T_2 = R_1C \ln \frac{3V_{OL} - V_{OH} - V^+}{2V_{OL} - V^+}$$

When $V_{OL} = 0V$

$$T_1 = R_2C \ln \frac{3V_{OH} - V^+}{2V_{OH} - V^+} \quad \text{and} \quad T_2 = R_1C \ln \left(1 + \frac{V_{OH}}{V^+} \right)$$

10006086

FIGURE 17. Waveforms of the Circuit in Figure 16

As shown in the waveforms in *Figure 17*, the pulse width (T_1) is set by R_2 , C and V_{OH} , and the time between pulses (T_2) is set by R_1 , C and V_{OL} . This pulse generator can be made to have different frequencies and pulse width by selecting different capacitor value and resistor values.

Figure 18 shows another pulse generator, with separate charge and discharge paths. The capacitor is charged through R_1 and is discharged through R_2 .

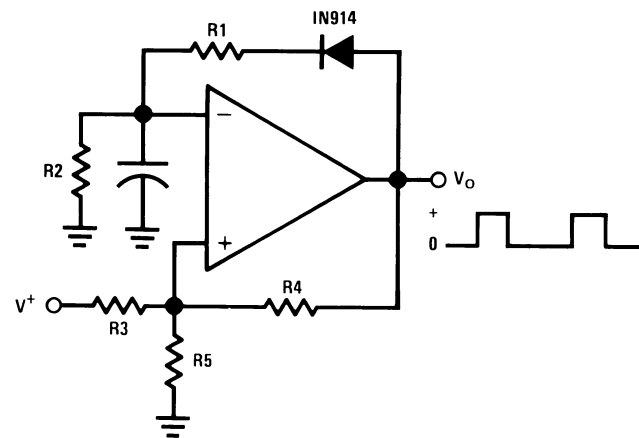

10006077

FIGURE 18. Pulse Generator

Figure 19 is a squarewave generator with the same path for charging and discharging the capacitor.

Application Notes (Continued)

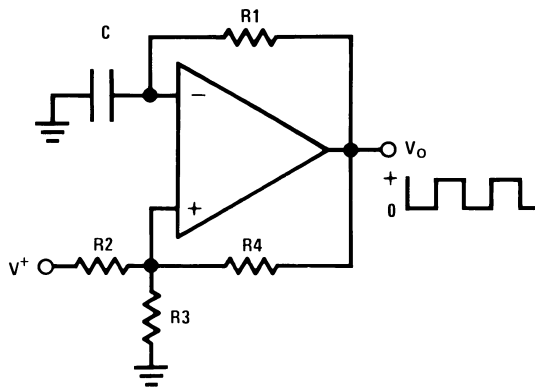

10006076

FIGURE 19. Squarewave Generator

4.6 CURRENT SOURCE AND SINK

The LMV321/358/324 can be used in feedback loops which regulate the current in external PNP transistors to provide current sources or in external NPN transistors to provide current sinks.

4.6.1 Fixed Current Source

A multiple fixed current source is shown in Figure 20. A voltage ($V_{REF} = 2V$) is established across resistor R_3 by the voltage divider (R_3 and R_4). Negative feedback is used to cause the voltage drop across R_1 to be equal to V_{REF} . This controls the emitter current of transistor Q_1 and if we neglect the base current of Q_1 and Q_2 , essentially this same current is available out of the collector of Q_1 .

Large input resistors can be used to reduce current loss and a Darlington connection can be used to reduce errors due to the β of Q_1 .

The resistor, R_2 , can be used to scale the collector current of Q_2 either above or below the 1mA reference value.

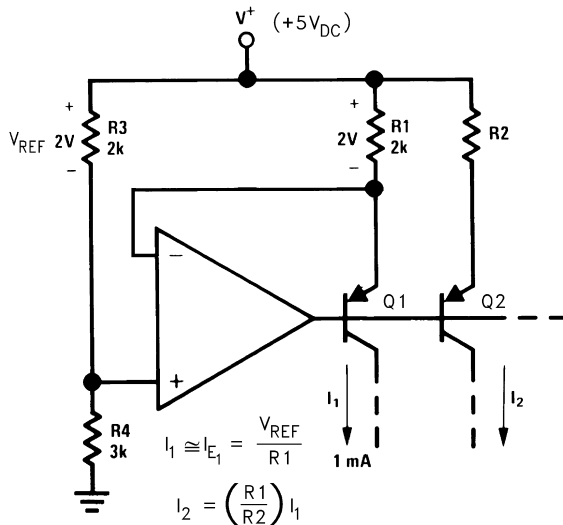

10006080

FIGURE 20. Fixed Current Source

4.6.2 High Compliance Current Sink

A current sink circuit is shown in Figure 21. The circuit requires only one resistor (R_E) and supplies an output current which is directly proportional to this resistor value.

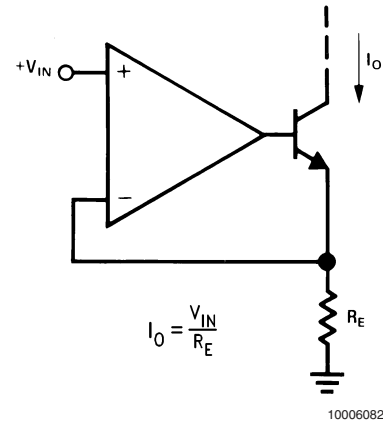

10006082

FIGURE 21. High Compliance Current Sink

4.7 POWER AMPLIFIER

A power amplifier is illustrated in Figure 22. This circuit can provide a higher output current because a transistor follower is added to the output of the op amp.

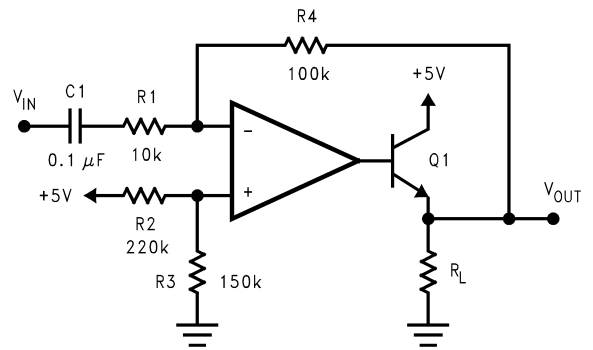

10006079

FIGURE 22. Power Amplifier

4.8 LED DRIVER

The LMV321/358/324 can be used to drive an LED as shown in Figure 23.

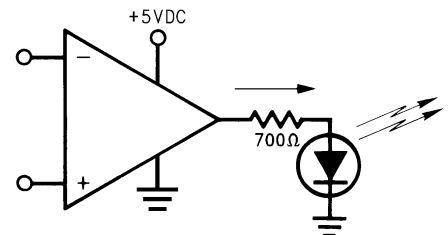

10006084

FIGURE 23. LED Driver

Application Notes (Continued)

4.9 COMPARATOR WITH HYSTERESIS

The LMV321/358/324 can be used as a low power comparator. *Figure 24* shows a comparator with hysteresis. The hysteresis is determined by the ratio of the two resistors.

$$V_{TH+} = V_{REF}/(1+R_1/R_2)+V_{OH}/(1+R_2/R_1)$$

$$V_{TH-} = V_{REF}/(1+R_1/R_2)+V_{OL}/(1+R_2/R_1)$$

$$V_H = (V_{OH}-V_{OL})/(1+R_2/R_1)$$

where

V_{TH+} : Positive Threshold Voltage

V_{TH-} : Negative Threshold Voltage

V_{OH} : Output Voltage at High

V_{OL} : Output Voltage at Low

V_H : Hysteresis Voltage

Since LMV321/358/324 have rail-to-rail output, the $(V_{OH}-V_{OL})$ equals to V_S , which is the supply voltage.

$$V_H = V_S/(1+R_2/R_1)$$

The differential voltage at the input of the op amp should not exceed the specified absolute maximum ratings. For real comparators that are much faster, we recommend you to use National's LMV331/393/339, which are single, dual and quad general purpose comparators for low voltage operation.

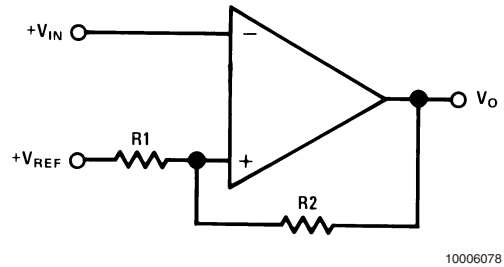
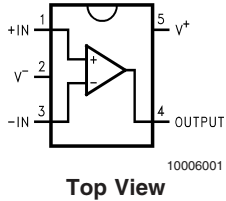

FIGURE 24. Comparator with Hysteresis

Connection Diagrams

5-Pin SC70-5/SOT23-5



8-Pin SO/MSOP

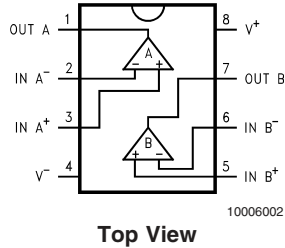

14-Pin SO/TSSOP

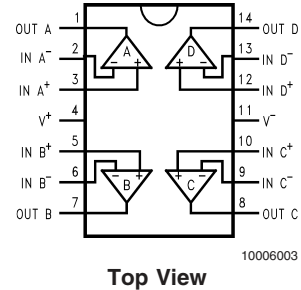

Ordering Information

Package	Temperature Range	Packaging Marking	Transport Media	NSC Drawing
	Industrial -40°C to +85°C			
5-Pin SC70-5	LMV321M7	A12	1k Units Tape and Reel	MAA05
	LMV321M7X	A12	3k Units Tape and Reel	
5-Pin SOT23-5	LMV321M5	A13	1k Units Tape and Reel	MA05B
	LMV321M5X	A13	3k Units Tape and Reel	
8-Pin Small Outline	LMV358M	LMV358M	Rails	M08A
	LMV358MX	LMV358M	2.5k Units Tape and Reel	
8-Pin MSOP	LMV358MM	LMV358	1k Units Tape and Reel	MUA08A
	LMV358MMX	LMV358	3.5k Units Tape and Reel	
14-Pin Small Outline	LMV324M	LMV324M	Rails	M14A
	LMV324MX	LMV324M	2.5k Units Tape and Reel	
14-Pin TSSOP	LMV324MT	LMV324MT	Rails	MTC14
	LMV324MTX	LMV324MT	2.5k Units Tape and Reel	

SC70-5 Tape and Reel Specification

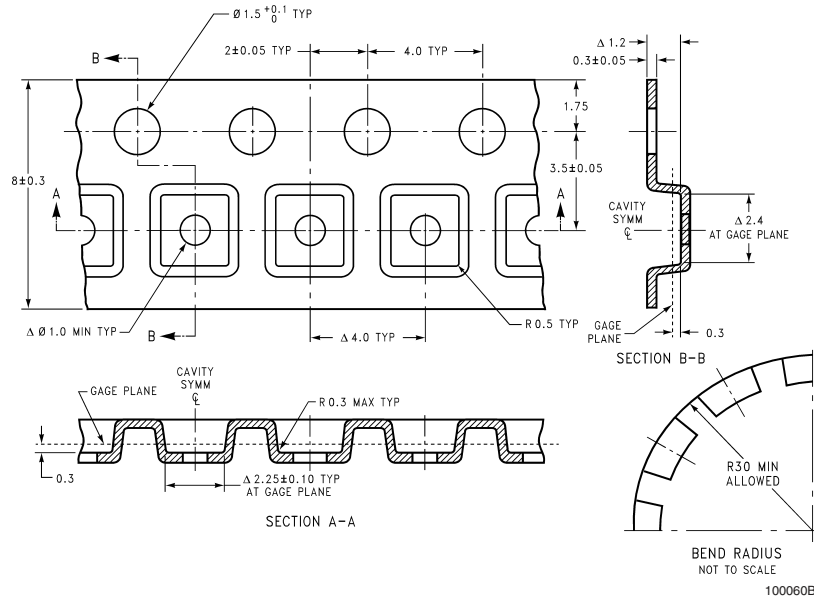

SOT-23-5 Tape and Reel Specification

TAPE FORMAT

Tape Section	# Cavities	Cavity Status	Cover Tape Status
Leader (Start End)	0 (min)	Empty	Sealed
	75 (min)	Empty	Sealed
Carrier	3000	Filled	Sealed
	250	Filled	Sealed
Trailer (Hub End)	125 (min)	Empty	Sealed
	0 (min)	Empty	Sealed

TAPE DIMENSIONS

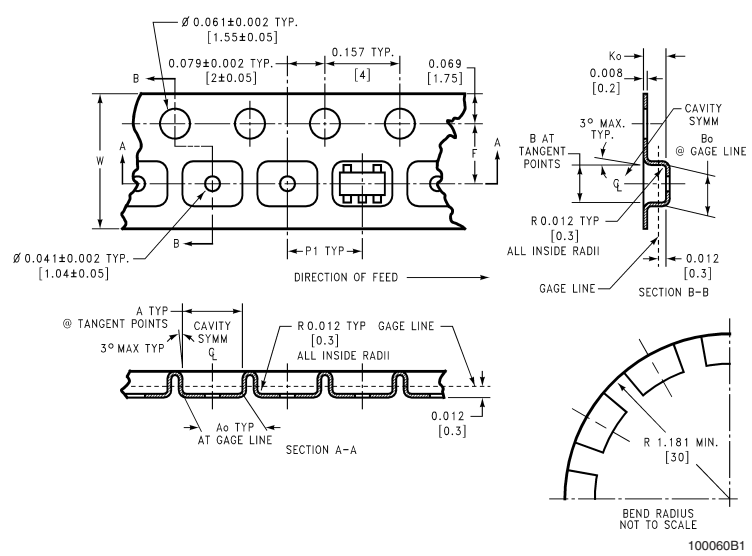

SOT-23-5 Tape and Reel Specification (Continued)

8 mm	0.130 (3.3)	0.124 (3.15)	0.130 (3.3)	0.126 (3.2)	0.138 ±0.002 (3.5 ±0.05)	0.055 ±0.004 (1.4 ±0.11)	0.157 (4)	0.315 ±0.012 (8 ±0.3)
Tape Size	DIM A	DIM A _o	DIM B	DIM B _o	DIM F	DIM K _o	DIM P1	DIM W

REEL DIMENSIONS

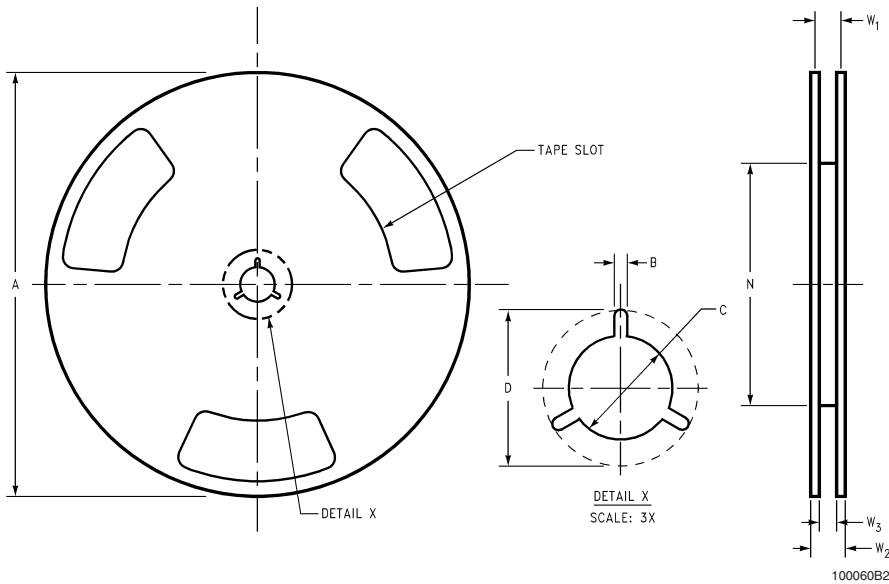

8 mm	7.00 330.00	0.059 1.50	0.512 13.00	0.795 20.20	2.165 55.00	0.331 + 0.059/-0.000 8.40 + 1.50/-0.00	0.567 14.40	W1 + 0.078/-0.039 W1 + 2.00/-1.00
Tape Size	A	B	C	D	N	W1	W2	W3

Physical Dimensions inches (millimeters)
unless otherwise noted

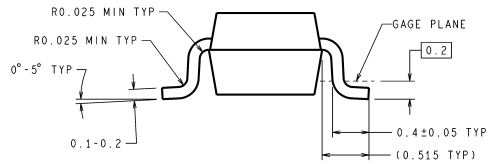
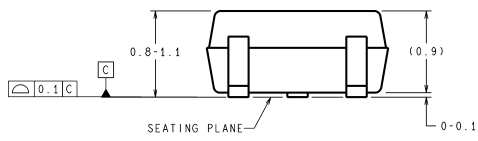
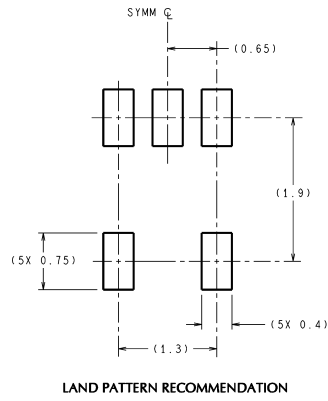
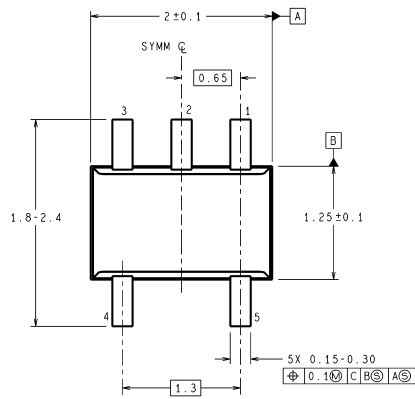

DIMENSIONS ARE IN MILLIMETERS

MAA05A (Rev C)

5-Pin SC70-5
NS Package Number MAA05A

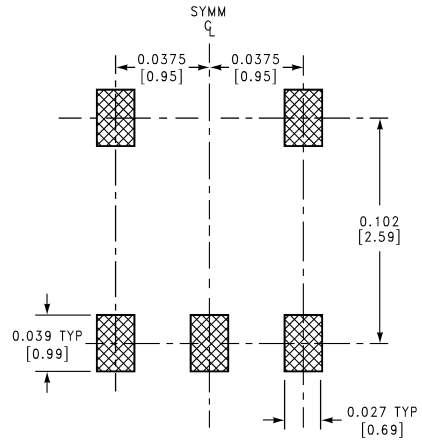
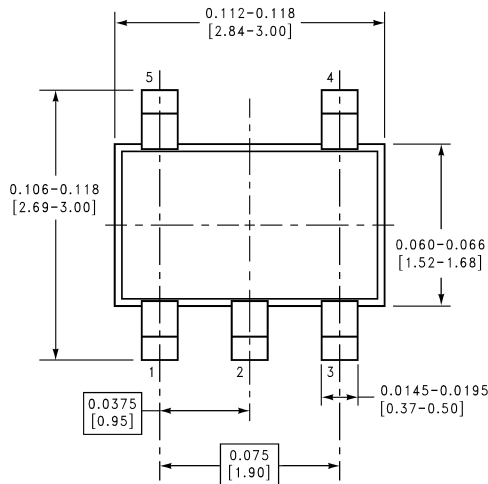

LAND PATTERN RECOMMENDATION

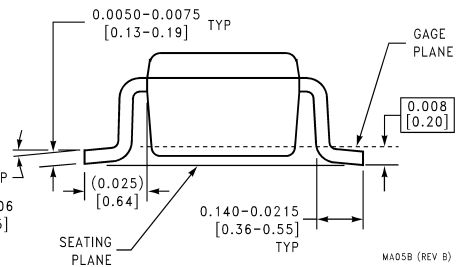
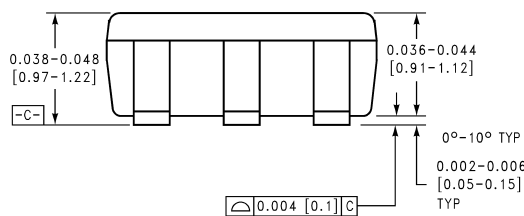

MA05B (REV B)

5-Pin SOT23-5
NS Package Number MA05B

Physical Dimensions inches (millimeters) unless otherwise noted (Continued)

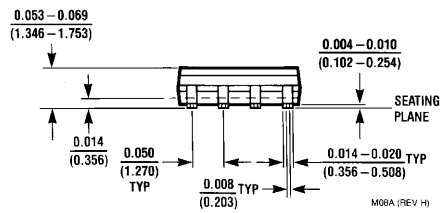
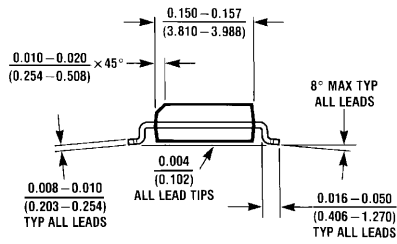
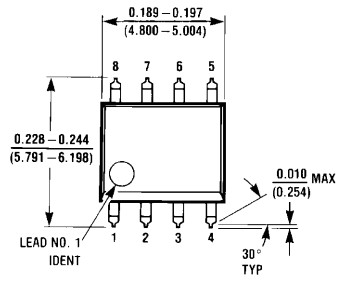

8-Pin SOIC
NS Package Number M08A

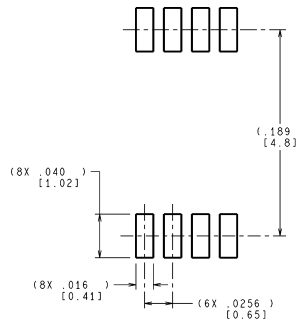
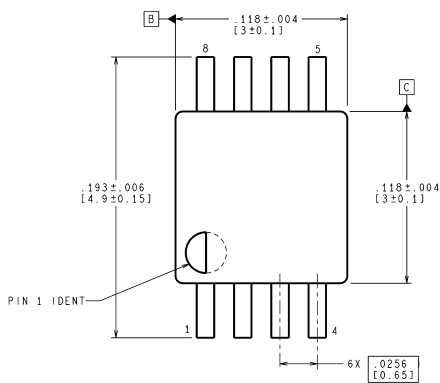

LAND PATTERN RECOMMENDATION

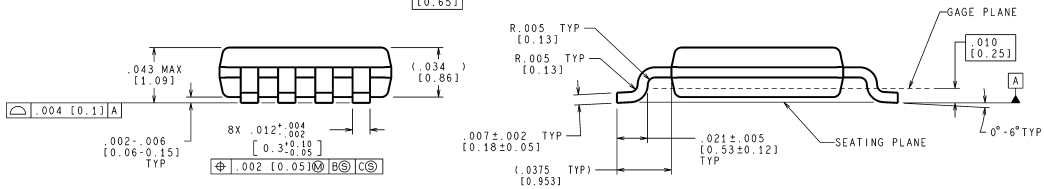

CONTROLLING DIMENSION IS INCH
VALUES IN [] ARE MILLIMETERS

MUA08A (Rev E)

8-Pin MSOPNS Package Number MUA08A

Physical Dimensions inches (millimeters) unless otherwise noted (Continued)

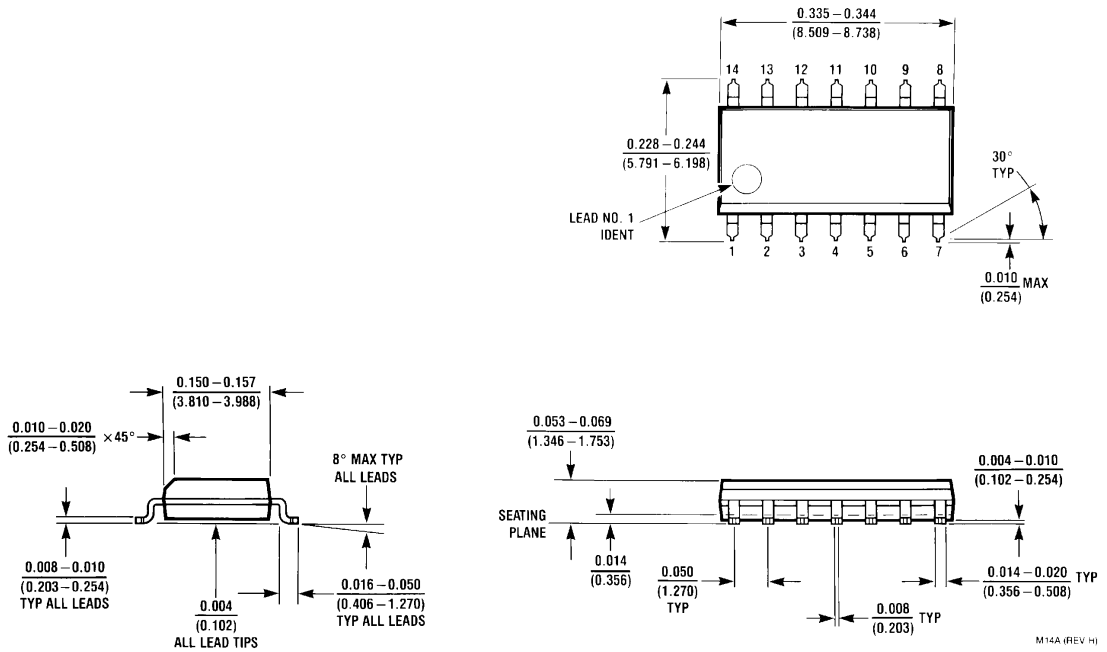

14-Pin SOIC
NS Package Number M14A

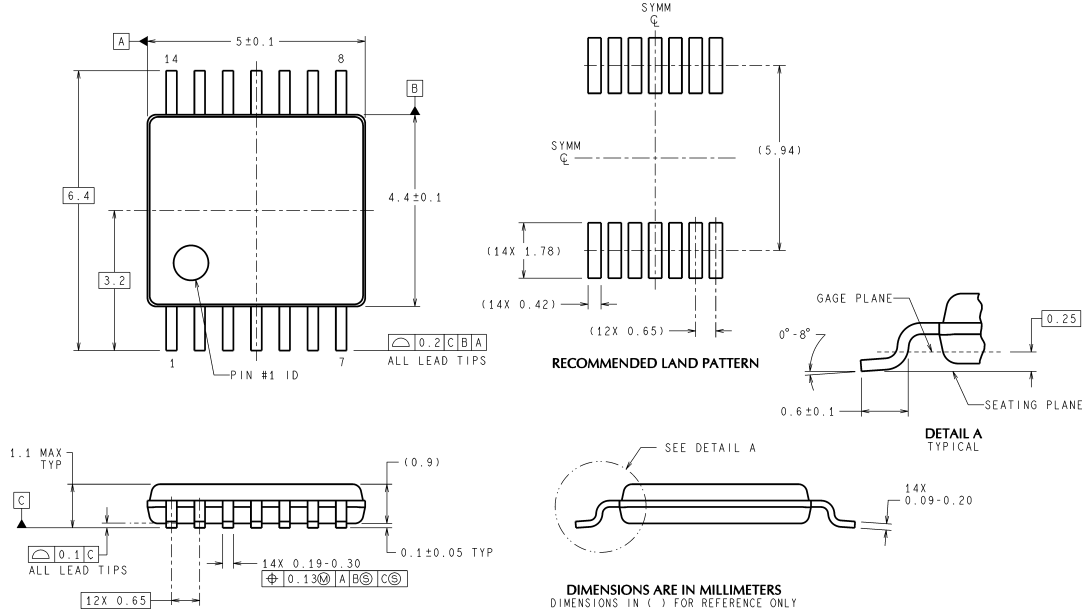

14-Pin TSSOPNS Package Number MTC14

MTC14 (Rev D)

Notes

LIFE SUPPORT POLICY

NATIONAL'S PRODUCTS ARE NOT AUTHORIZED FOR USE AS CRITICAL COMPONENTS IN LIFE SUPPORT DEVICES OR SYSTEMS WITHOUT THE EXPRESS WRITTEN APPROVAL OF THE PRESIDENT AND GENERAL COUNSEL OF NATIONAL SEMICONDUCTOR CORPORATION. As used herein:

1. Life support devices or systems are devices or systems which, (a) are intended for surgical implant into the body, or (b) support or sustain life, and whose failure to perform when properly used in accordance with instructions for use provided in the labeling, can be reasonably expected to result in a significant injury to the user.
2. A critical component is any component of a life support device or system whose failure to perform can be reasonably expected to cause the failure of the life support device or system, or to affect its safety or effectiveness.



**National Semiconductor
Americas Customer
Support Center**
Email: new.feedback@nsc.com
Tel: 1-800-272-9959

www.national.com

**National Semiconductor
Europe Customer Support Center**
Fax: +49 (0) 180-530 85 86
Email: europe.support@nsc.com
Deutsch Tel: +49 (0) 69 9508 6208
English Tel: +44 (0) 870 24 0 2171
Français Tel: +33 (0) 1 41 91 8790

**National Semiconductor
Asia Pacific Customer
Support Center**
Email: ap.support@nsc.com

**National Semiconductor
Japan Customer Support Center**
Fax: 81-3-5639-7507
Email: jpn.feedback@nsc.com
Tel: 81-3-5639-7560