



April 1995

## LMX2240 Intermediate Frequency Receiver

### General Description

The LMX2240 is a monolithic, integrated intermediate frequency receiver suitable for use in Digital European Cordless Telecommunications (DECT) systems as well as other mobile telephony and wireless communications applications. It is fabricated using National's ABIC<sup>TM</sup> IV BiCMOS process ( $f_T = 15$  GHz).

The LMX2240 consists of a high gain limiting amplifier, a frequency discriminator, and a received signal strength indicator (RSSI). The high gain limiting amplifier and discriminator operate in the 40 MHz to 150 MHz frequency range, and the limiter has approximately 70 dB of gain. The use of the limiter and the discriminator provides a low cost, high performance demodulator for communications systems. The RSSI output can be used for channel quality monitoring.

The LMX2240 is intended to support single conversion receivers. This device saves power, size, and cost by eliminating the second local oscillator (LO), second converter (mixer), and additional filters. The LMX2240 is recommended for systems with channel bandwidths of 300 kHz to 2.5 MHz.

The LMX2240 is available in a 16-pin JEDEC surface mount plastic package.

### Features

- Typical operation at 110 MHz
- RF sensitivity to  $-75$  dBm; RSSI sensitivity to  $-82$  dBm
- High gain (70 dB) limiting amplifier
- Average current consumption:  $480 \mu\text{A}$  for DECT handset (burst mode)
- $+3\text{V}$  operation
- Power down mode for increased current savings
- Part of a complete receiver solution with the LMX2216 LNA/Mixer, the LMX2315/20 Phase-locked Loop, and the LMX2411 Baseband Processor
- Compliant to ARI<sup>1</sup><sup>TM</sup> specification

### Applications

- Digital European Cordless Telecommunications (DECT)
- Portable wireless communications (PCS/PCN, cordless)
- Wireless local area networks (WLANs)
- Digital cellular telephone systems
- Other wireless communications systems

### Functional Block Diagram

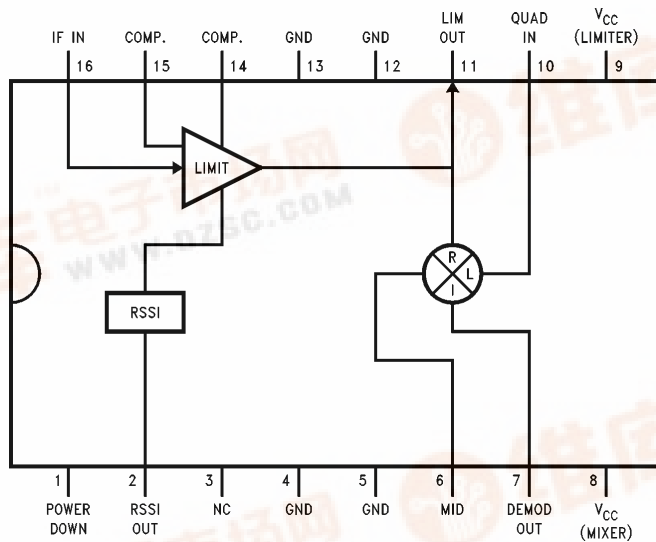

TL/W/11755-1

ABIC<sup>TM</sup> and ARI<sup>1</sup><sup>TM</sup> are trademarks of National Semiconductor Corporation.



## Connection Diagram

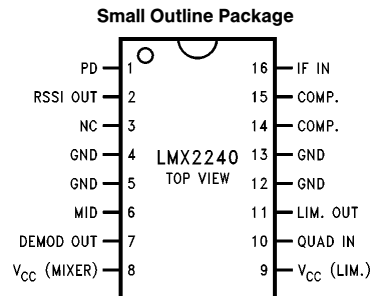

TL/W/11755-2

**Top View  
Order Number LMX2240M  
See NS Package Number M16A**

## Pin Description

Pin No.	Pin Name	I/O	Description
1	PD	I	Power Down; a HIGH signal switches the part to power down mode.
2	RSSI Out	O	Voltage output of the received signal strength indicator (RSSI).
3	NC		No connection
4	GND		Ground
5	GND		Ground
6	MID	O	Mid-range output of the discriminator; can be used for comparator threshold.
7	Demod Out	O	Demodulated output of the discriminator.
8	V <sub>CC</sub> (Mixer)		Source voltage for the mixer (discriminator).
9	V <sub>CC</sub> (Lim.)		Source voltage for the limiter.
10	Quad In	I	Quadrature input. A DC path from source through an inductor must be present at this pin, but, there must be no series resistance (a parallel resistor to the inductor is acceptable).
11	Lim. Out	O	Limiter output to the quadrature tank.
12	GND		Ground
13	GND		Ground
14	Comp.		Compensation pin for the limiter. See Applications Information for capacitor value.
15	Comp.		Compensation pin for the limiter. See Applications Information for capacitor value.
16	IF In	I	IF input to the limiter.

## Absolute Maximum Ratings

If Military/Aerospace specified devices are required, please contact the National Semiconductor Sales Office/Distributors for availability and specifications.

Power Supply Voltage ( $V_{CC}$ )	6.5V
Storage Temperature Range ( $T_S$ )	-65°C to +150°C
Lead Temperature ( $T_L$ ) (Soldering, 10 seconds)	+260°C

## Recommended Operating Conditions

	Min	Max	Units
Supply Voltage ( $V_{CC}$ )	2.85	3.15	V
Operating Temperature ( $T_A$ )	-10	+70	°C

## Electrical Characteristics

The following specifications apply for supply voltage  $V_{CC} = +3V \pm 5\%$ ,  $f_{IN} = 120$  MHz, and  $T_A = 25^\circ\text{C}$  unless otherwise specified

Symbol	Parameter	Conditions	Min	Value Typ	Max	Units
$I_{DD}$	Supply Current			8	10	mA
$I_{PD}$	Power Down Current			115	200	$\mu\text{A}$
$f_{max}$	Maximum IF Input Frequency		120	150		MHz
$f_{min}$	Minimum IF Input Frequency			10		MHz
<b>IF LIMITER</b>						
NF	IF Limiter Noise Figure			11.5	12.5	dB
$A_V$	Limiter Gain	$Z_L = 1000\Omega$		70		dB
sens	Limiter/Disc. Sensitivity	BER = 0.001		-75		dBm
$IF_{in}$	IF Limiter Input Impedance		150		225	$\Omega$
$IF_{out}$	IF Limiter Output Impedance			250		$\Omega$
$V_{max}$	Maximum Input Voltage Level			500		mV <sub>PP</sub>
$V_{out}$	Output Swing		350	500		V <sub>PP</sub>
Lim	Input Limiting Point			-70		dBm
<b>DISCRIMINATOR</b>						
$V_{out}$	Discriminator Output Peak-to-Peak Voltage (Note 1)	See Test Circuit	1.0	1.2		V <sub>PP</sub>
$V_{OS}$	Disc. Output DC Voltage (Pin 7)		1.4		1.7	V
MID	Mid-Range Output (Pin 6)		1.4		1.7	V
$DISC_{in}$	Disc. Input Impedance			1000		$\Omega$
$DISC_{out}$	Disc. Output Impedance			150		$\Omega$
<b>RSSI</b>						
RSSI	RSSI Dynamic Range			70		dB
$RSSI_{out}$	RSSI Output Voltage	Pin = -80 dBm	0.35	0.5	0.8	V
		Pin = 0 dBm	1.15	1.5	1.8	V
	RSSI Slope	Pin = -70 dBm to -20 dBm	11	16		mV/dB
	RSSI Linearity			3		dB

**Note 1:** The discriminator output peak-to-peak voltage is measured by operating the discriminator mixer with two separate inputs (i.e., as a mixer). A beat frequency of 1 kHz is generated, and this tone's output swing is guaranteed to be at least 1.0 V<sub>PP</sub>. When the mixer is configured as a discriminator with the limiter and a tank circuit, the guaranteed 1.0 V<sub>PP</sub> output translates to  $(1.0V \cdot (36/180) = )$  200 mV<sub>PP</sub> demodulated output, assuming at least 36° phase shift across the band of interest from the tank circuit.

## Typical Application Block Diagram

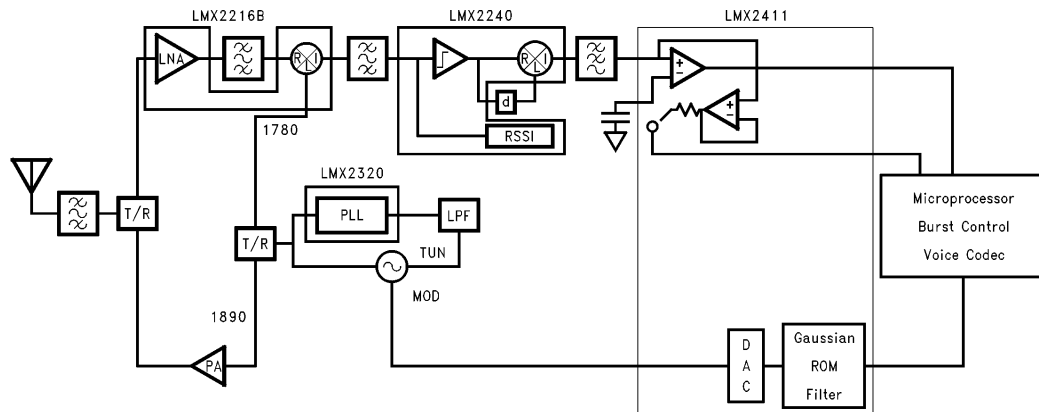

TL/W/11755-3

## Functional Description

### OVERVIEW

The LMX2240 IF demodulator is a low power IF processor that includes a frequency discriminator, an IF hard limiting amplifier, and a received signal strength indicator (RSSI). The LMX2240 is capable of differentially demodulating an FM or AM signal with as high an IF as 150 MHz, avoiding a costly second down-conversion. The RSSI output can be used for time gated channel measurements required in TDMA and other systems. Other features include high receiver sensitivity and a power down mode to allow for stand-by operation.

### THE LIMITING AMPLIFIER

The limiting amplifier has a typical gain of 70 dB and a sensitivity of about  $-75$  dBm. This allows it to be used in the DECT system with 20 dB net RF gain in front of it to achieve a sensitivity of  $-95$  dBm. The limiter is a five stage amplifier with internal compensation at each stage to ensure stability. Two external compensation capacitors are also required to further enhance stability. The input to the limiter is a relatively low impedance to allow easy matching to typical IF surface acoustic wave (SAW) filters. The output of the limiter is connected off chip to an external quadrature tank circuit as well as connected internally to the discriminator (mixer). The output impedance of the limiter is  $250\Omega$  (typical).

### THE RECEIVED SIGNAL STRENGTH INDICATOR (RSSI)

The RSSI circuit has a range of 70 dB. Its output voltage is proportional to the logarithm of the input signal level. The RSSI circuit has a sensitivity of  $-82$  dBm. The output voltage of the circuit ranges from 0.5V to 1.5V typically.

### THE FREQUENCY DISCRIMINATOR

The frequency discriminator is a Gilbert cell mixer that requires an external tank circuit to create a  $90^\circ$  phase shift at the desired frequency. The output of this circuit is centered at 1.5V by an internal level shifting circuit, and a mid-range voltage (at 1.5V) is also provided. The sensitivity of the discriminator to phase inaccuracies is 5.5 mV/degree (see Applications Information). This means that for a phase imbalance of  $10^\circ$ , the received eye diagram will be shifted by about 55 mV off of the 1.5V mid-range voltage. For the typical case, this amounts to about 10% of the output eye diagram (for 400 mV<sub>pp</sub> output).

## Typical Performance Characteristics

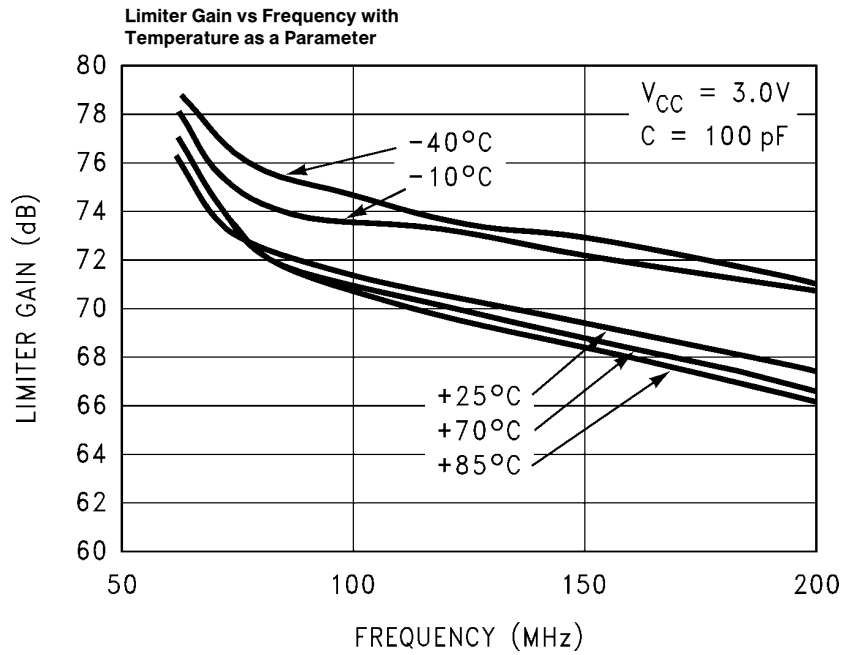

TL/W/11755-4

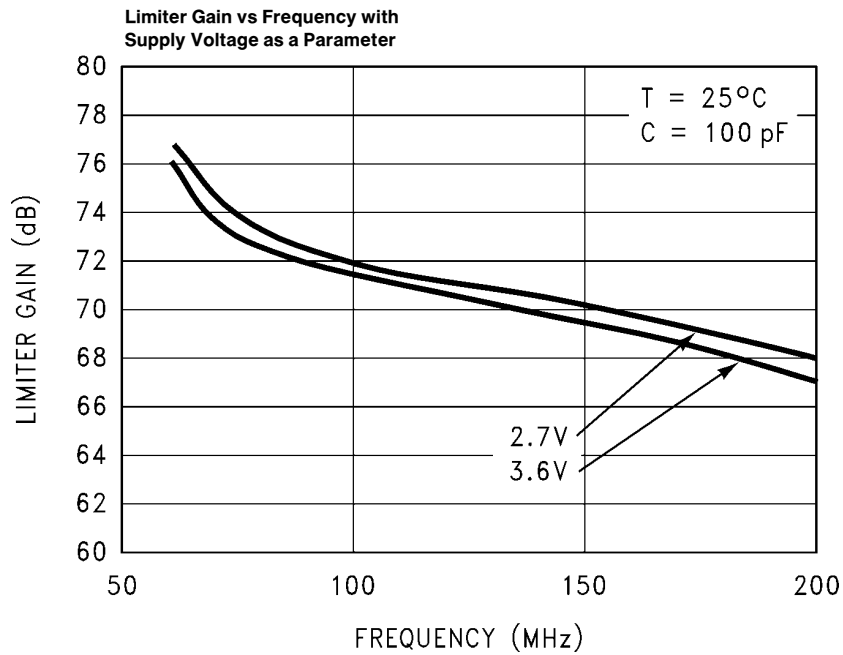

TL/W/11755-5

## Typical Performance Characteristics (Continued)

**Discriminator Output Peak-to-Peak Voltage vs Supply with Temperature as a Parameter**

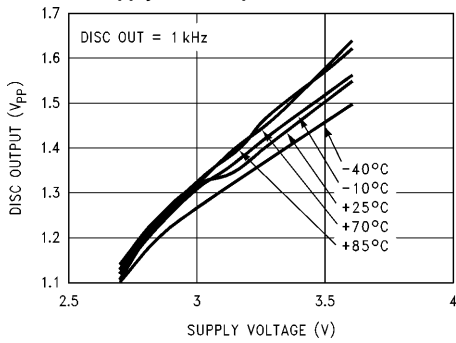

**Current Consumption vs Supply Voltage with Temperature as a Parameter**

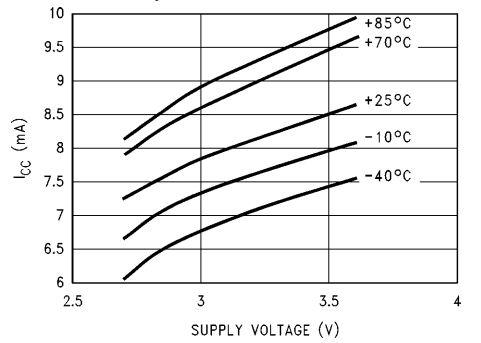

**Mid-Range (Reference) Voltage vs Supply with Temperature as a Parameter**

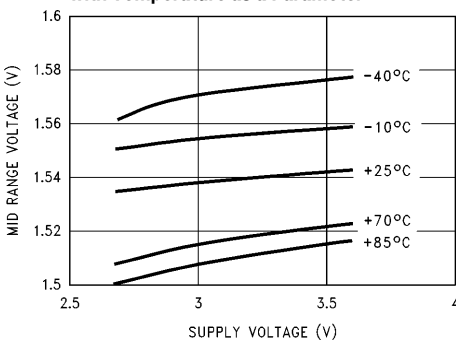

**Power Down Current vs Temperature**

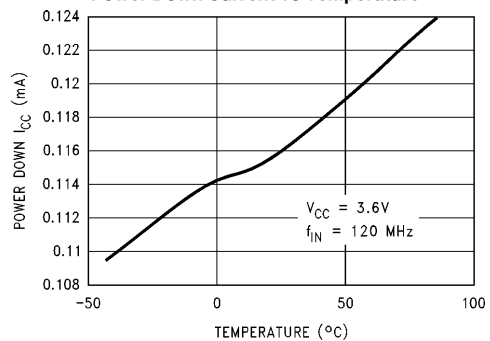

**Limiter Output Power vs Frequency with Voltage as a Parameter**

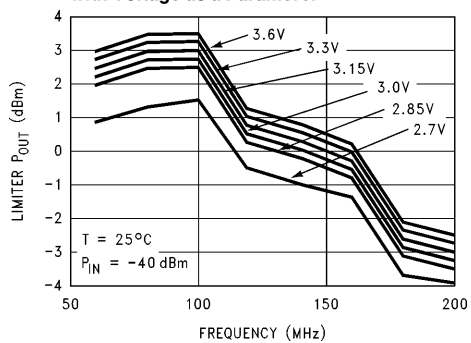

**Limiter Output Power vs Frequency with Temperature as a Parameter**

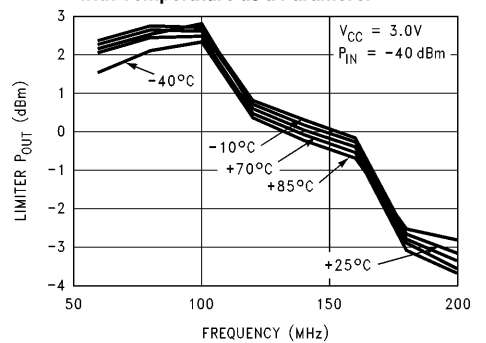

**Typical Performance Characteristics** (Continued)

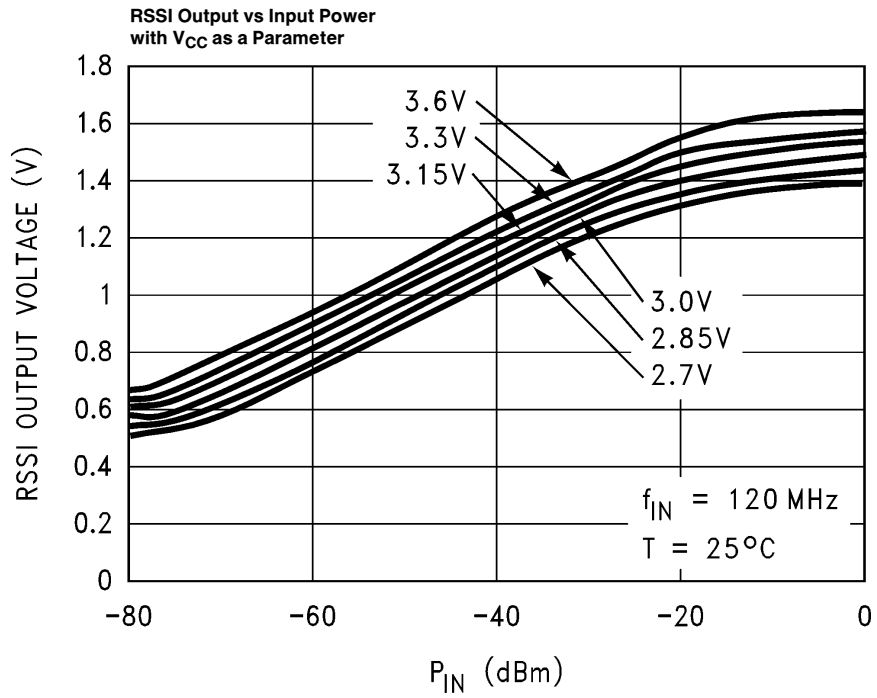

TL/W/11755-12

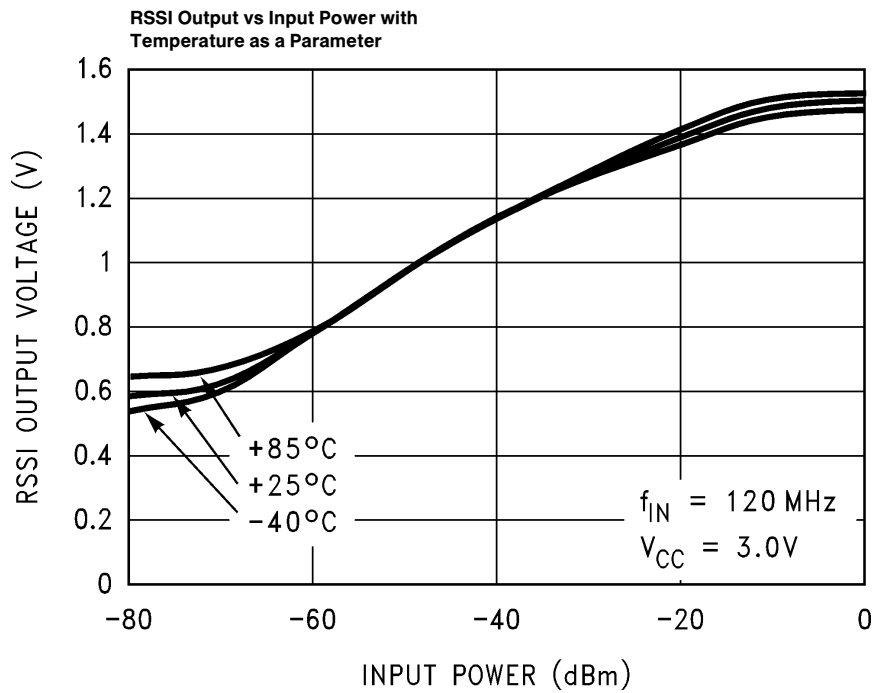

TL/W/11755-13

## Automatic Test Circuit

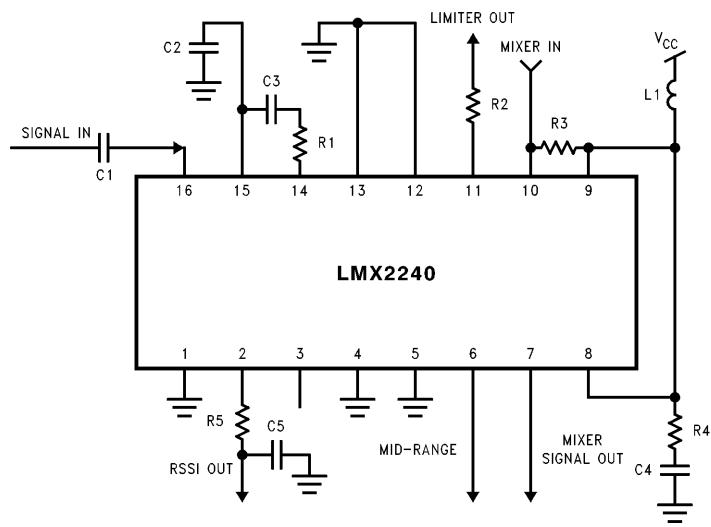

TL/W/11755-14

- |                                     |                                   |
|-------------------------------------|-----------------------------------|
| C1 = 1000 pF ±10% NPO Ceramic       | C2 = 1000 pF ±10% NPO Ceramic     |
| C3 = 1000 pF ±10% NPO Ceramic       | R1 = 25Ω ±5% ¼W Thin Film Carbon  |
| R2 = 1 kΩ ±5% ¼W Thin Film Carbon   | R3 = 1 kΩ ±5% ¼W Thin Film Carbon |
| L1 = 10 μH ±5% Air Coil             | C4 = 1000 pF ±10% NPO Ceramic     |
| R4 = 20Ω ±5% ¼W Thin Film Carbon    | C5 = 1000 pF ±10% NPO Ceramic     |
| R5 = 3.9 kΩ ±5% ¼W Thin Film Carbon |                                   |



## Typical Application Example

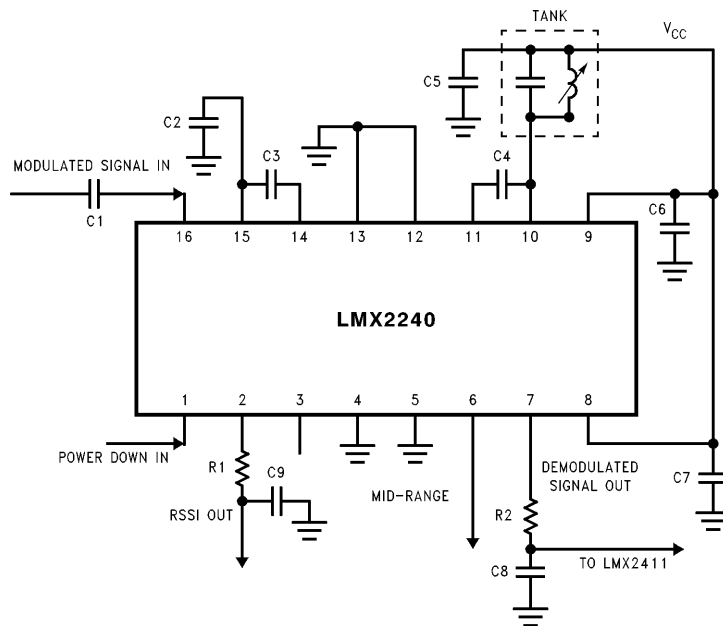

- C1 = C2 = C3 = C5 = C6 = 100 pF  $\pm$ 10% NPO Ceramic  
 C4 = 1 pF  $\pm$ 10% NPO Ceramic  
 C7 = C9 = 0.01  $\mu$ F  $\pm$ 10% NPO Ceramic  
 C8 = 82 pF  $\pm$ 10% X7R Ceramic  
 R1 = 4 k $\Omega$   $\pm$ 5%  $\frac{1}{4}$ W Thin Film Carbon  
 R2 = 880 $\Omega$   $\pm$ 5%  $\frac{1}{4}$ W Thin Film Carbon  
 Tank = Toko #638AH-0294  
 All supporting components 0603 surface mount except tank.

TL/W/11755-15

## Applications Information

### THE INTERMEDIATE FREQUENCY LIMITER

The IF limiter has a large amount of gain at high enough frequency to cause concern about oscillation. To ensure that the limiter does not oscillate, a few precautions should be taken. The compensation capacitors that are used should be chosen to roll off any unwanted frequencies below the band of interest. The capacitor should be a high Q, RF type ceramic chip capacitor. For DECT, the capacitor value should be 100 pF, and the capacitors should be soldered as close to the LMX2240 as possible. This will create a pass band from 40 MHz to 150 MHz. The AC coupling capacitor at the input to the limiter (from the SAW filter) should be the same value as the compensation capacitors.

### THE DISCRIMINATOR

There are two types of discriminator that can be used to demodulate FM signals. The first is a delay line discriminator, which uses a delay in one path of the received signal to introduce a phase difference between it and the received signal. The operation of the delay line discriminator is derived in the inset box. The other type of discriminator relies on a quadrature tank to directly introduce a phase shift in the received signal. This is the type of implementation that is commonly used in mobile communications because of its relative ease of construction and low cost.

The discriminator operates best when the inputs to it are hard-limited (i.e., square edges). If the input signal is small enough such that the IF amplifier cannot limit it, the output voltage swing of the limiter will suffer. Typically, the minimum voltage swing the discriminator can see and still fully switch is about 100 mV<sub>pp</sub>. The two inputs to the discriminator can be of different peak-to-peak voltage swings as long as both are over the lower limit. This allows the quadrature tank circuit to have some insertion loss. In fact, up to 8 dB insertion loss can be tolerated while still ensuring that the discriminator output won't suffer.

The quadrature circuit can also affect the discriminator output voltage swing. The discriminator output voltage swing specified assumes perfect quadrature at the frequency of interest (mixer operation). With available analog components, perfect quadrature is not possible. This is due in part to the high frequency of the IF and the proportionally very narrow bandwidth of the desired signal. For example, a DECT signal is about 1 MHz wide, which is < 1% of the IF at which the demodulation occurs. This makes the quadrature circuit difficult to achieve. With moderately high Q components, however, a reasonable phase shift can be achieved with a single pole tank. This is illustrated by the following equation: the output of the discriminator is given by

$$\text{DISC}_{\text{out}} = \cos(\omega_c t) \cdot \cos(\omega_c t + \phi), \quad (1)$$

which results in

$$\text{DISC}_{\text{out}} = \cos(\omega_c t + \omega_c t + \phi) + \cos(\omega_c t - \omega_c t - \phi). \quad (2)$$

When the double frequency component is filtered out with a low pass filter, the cosine of the phase remains

$$\text{DISC}_{\text{out}} = \cos(-\phi) = \cos(\phi). \quad (3)$$

It can be seen that at 90° phase shift, the output will be zero. At 0°, the output will be 0.5, and at 180°, it will be -0.5. The output swing is then set by the multiplication of the cosine term with the discriminator output amplifier's gain.

With a circuit that gives an output peak-to-peak voltage of 1.0 V<sub>pp</sub> (min) with ideal quadrature, the slope is seen to be 5.5 mV/degree. With a practical quadrature tank circuit at 110.6 MHz, the phase shift over a 1 MHz bandwidth is about 45°–50°, which translates to an output peak-to-peak voltage of about 250 mV<sub>pp</sub>.

Assume the FM modulated signal is denoted as

$$s(t) = \cos(\omega_c t + m(t)), \quad (4)$$

$$\text{where } m(t) = m \int_{-\infty}^t b(t) dt,$$

and b(t) is the modulating baseband signal. The constant m is defined as  $m = 2\Delta f T_b$ . The signal s(t) must be delayed by some  $\tau$  so that

$$l(t) = s(t + \tau) = \cos(\omega_c(t + \tau) + m(t + \tau)). \quad (5)$$

If the delay  $\tau$  is such that

$$\omega_c \tau = 2n\pi + \frac{\pi}{2}, \quad n = 0, 1, 2, 3, \dots, \quad (6)$$

$$\text{then } s(t + \tau) = \sin(\omega_c t + m(t + \tau)), \quad (7)$$

and multiplying (4) and (7) yields

$$\begin{aligned} s(t)l(t) &= \cos(\omega_c t + m(t)) \sin(\omega_c t + m(t + \tau)) \\ &= \frac{1}{2} \sin(2\omega_c t + m(t) + m(t + \tau)) \\ &\quad + \frac{1}{2} \sin(m(t + \tau) - m(t)). \end{aligned} \quad (8)$$

The double frequency component can be filtered off with a lowpass filter. If  $\tau$  is kept small,

$$\begin{aligned} \frac{1}{2} \sin(m(t + \tau) - m(t)) &\approx \frac{1}{2} [m(t + \tau) - m(t)] \\ &= \frac{m}{2} \int_{-\infty}^{t + \tau} b(t) dt - \\ &\quad \frac{m}{2} \int_{-\infty}^t b(t) dt \\ &= \frac{m}{2} \int_t^{t + \tau} b(t) dt \\ &\approx \tau \frac{m}{2} b(t). \end{aligned} \quad (9)$$

The object for a delay line, then, is to maximize the delay while retaining the approximations necessary to satisfy (9),  $\tau < 0.1 T_b$ .

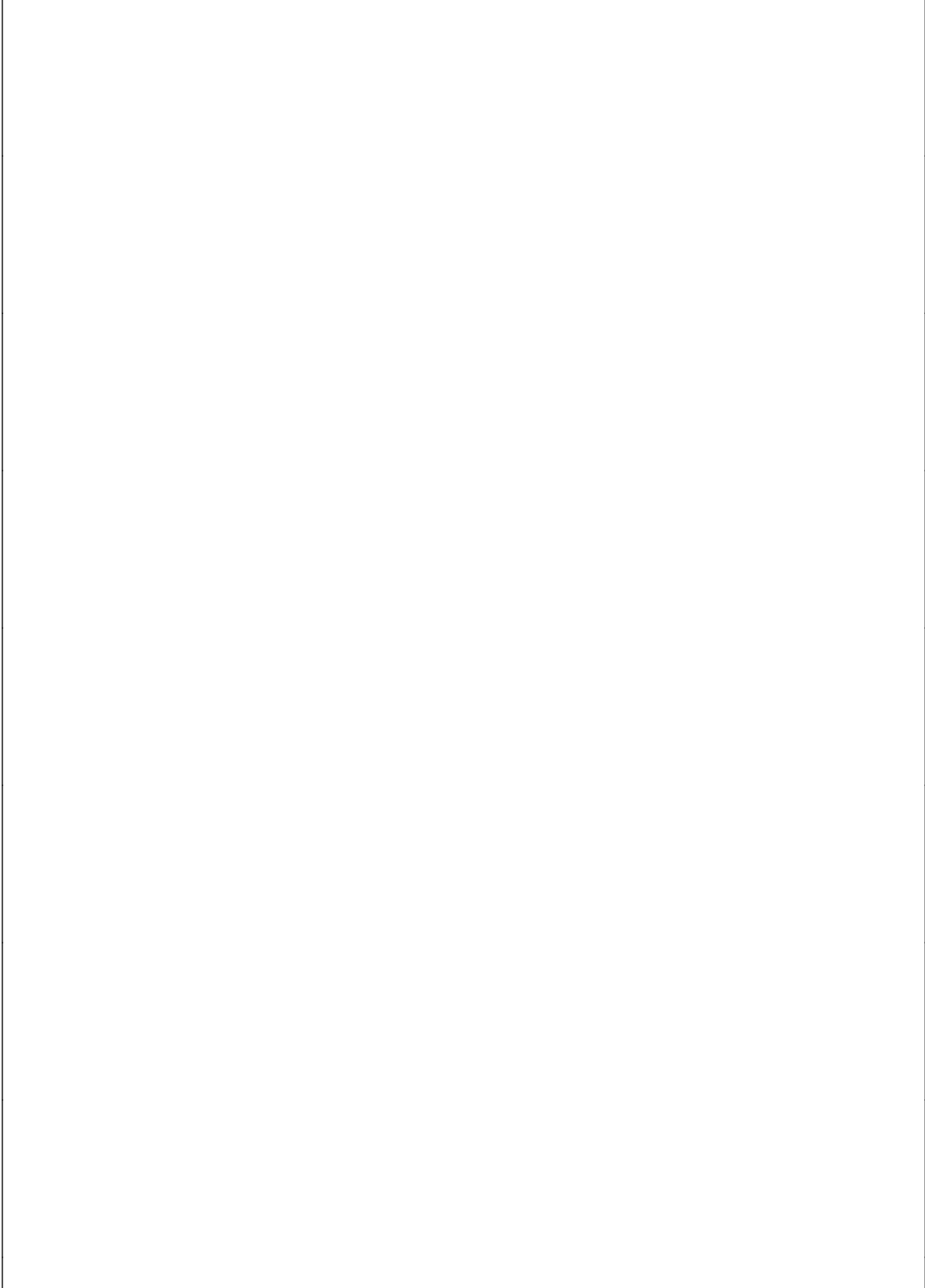

**Physical Dimensions** inches (millimeters)

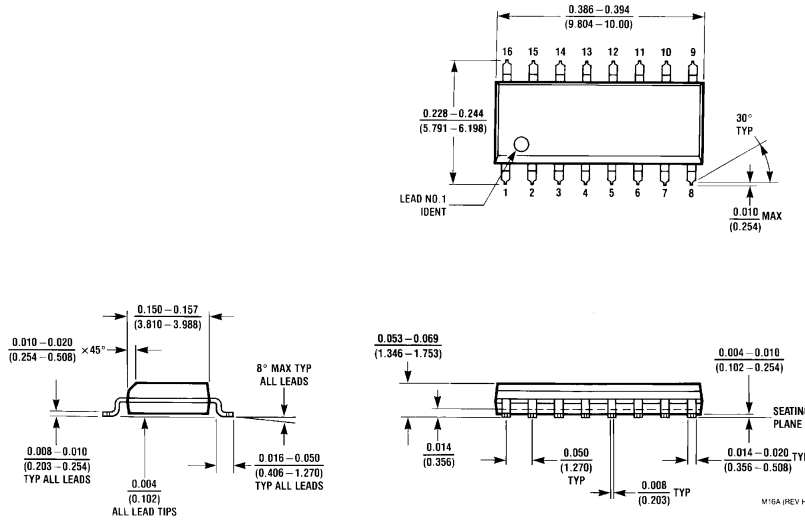

**16-Lead Molded Package (SO)**  
**Order Number LMX2240M**  
**For Tape and Reel Order Number LMX2240MX**  
**NS Package Number M16A**

**LIFE SUPPORT POLICY**

NATIONAL'S PRODUCTS ARE NOT AUTHORIZED FOR USE AS CRITICAL COMPONENTS IN LIFE SUPPORT DEVICES OR SYSTEMS WITHOUT THE EXPRESS WRITTEN APPROVAL OF THE PRESIDENT OF NATIONAL SEMICONDUCTOR CORPORATION. As used herein:

1. Life support devices or systems are devices or systems which, (a) are intended for surgical implant into the body, or (b) support or sustain life, and whose failure to perform, when properly used in accordance with instructions for use provided in the labeling, can be reasonably expected to result in a significant injury to the user.
2. A critical component is any component of a life support device or system whose failure to perform can be reasonably expected to cause the failure of the life support device or system, or to affect its safety or effectiveness.



**National Semiconductor Corporation**  
 1111 West Bardin Road  
 Arlington, TX 76017  
 Tel: 1(800) 272-9959  
 Fax: 1(800) 737-7018

**National Semiconductor Europe**  
 Fax: (+49) 0-180-530 85 86  
 Email: cnjwge@tevm2.nsc.com  
 Deutsch Tel: (+49) 0-180-530 85 85  
 English Tel: (+49) 0-180-532 78 32  
 Français Tel: (+49) 0-180-532 93 58  
 Italiano Tel: (+49) 0-180-534 16 80

**National Semiconductor Hong Kong Ltd.**  
 13th Floor, Straight Block,  
 Ocean Centre, 5 Canton Rd.  
 Tsimshatsui, Kowloon  
 Hong Kong  
 Tel: (852) 2737-1600  
 Fax: (852) 2736-9960

**National Semiconductor Japan Ltd.**  
 Tel: 81-043-299-2309  
 Fax: 81-043-299-2408