

Numeric Display

#/ 14.4 mm (.6") Series

Conventional Part No.	Global Part No.	Lighting Color
LN506RA	LNM276AA01	Red
LN506RK	LNM276KA01	Red
LN506GA	LNM376AA01	Green
LN506GK	LNM376KA01	Green

Terminal Connection

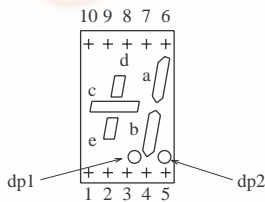

Pin No.	Assignment	Assignment
1	Cathode e	Anode e
2	Common Anode c, d, e	Common Cathode c, d, e
3	Cathode b	Anode b
4	Common Anode a, b, dp1, dp2	Common Cathode a, b, dp1, dp2
5	Cathode dp1, dp2	Anode dp1, dp2
6	Cathode a	Anode a
7	Common Anode a, b, dp1, dp2	Common Cathode a, b, dp1, dp2
8	Common Anode c, d, e	Common Cathode c, d, e
9	Cathode d	Anode d
10	Cathode c	Anode c

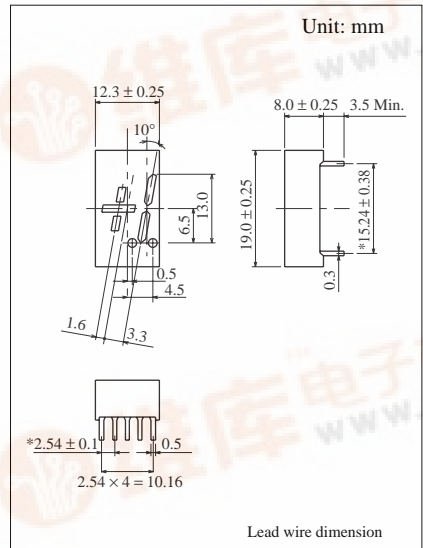

Absolute Maximum Ratings (T_a = 25°C)

Lighting Color	P _D (mW)	I _F (mA)	I _{FP} (mA)*	V _R (V)	T _{opr} (°C)	T _{stg} (°C)
Red	60	20	100	5	-25 ~ +80	-30 ~ +85
Green	60	20	100	5	-25 ~ +80	-30 ~ +85

I_{FP}的条件は duty 10%, Pulse width 1 msec. The condition of I_{FP} is duty 10%, Pulse width 1 msec

Electro-Optical Characteristics (T_a = 25°C)

Conventional Part No.	Lighting Color	Common	I _O / seg		I _O / d.p		I _F	V _F		λ _p	Δλ	I _F	I _R	
			Typ	Min	Typ	I _F		Typ	Max				Typ	Max
LN506RA	Red	Anode	450	150	150	5	2.2	2.8	700	100	20	10	5	
LN506RK	Red	Cathode	450	150	150	5	2.2	2.8	700	100	20	10	5	
LN506GA	Green	Anode	1500	500	500	10	2.2	2.8	565	30	20	10	5	
LN506GK	Green	Cathode	1500	500	500	10	2.2	2.8	565	30	20	10	5	
Unit	—	—	μcd	μcd	μcd	mA	V	V	nm	nm	mA	μA	V	

