

LNA4401L

GaAlAs Infrared Light Emitting Diode

For optical control systems

Features

- High-power output, high-efficiency : $P_O = 10 \text{ mW}$ (typ.)
- Fast response and high-speed modulation capability :
 $f_C = 20 \text{ MHz}$ (typ.)
- TO-18 standard type package

Absolute Maximum Ratings ($T_a = 25^\circ\text{C}$)

Parameter	Symbol	Ratings	Unit
Power dissipation	P_D	190	mW
Forward current (DC)	I_F	100	mA
Pulse forward current	I_{FP}^*	1	A
Reverse voltage (DC)	V_R	3	V
Operating ambient temperature	T_{opr}	-25 to +85	$^\circ\text{C}$
Storage temperature	T_{stg}	-30 to +100	$^\circ\text{C}$

* $f = 100 \text{ Hz}$, Duty cycle = 0.1 %

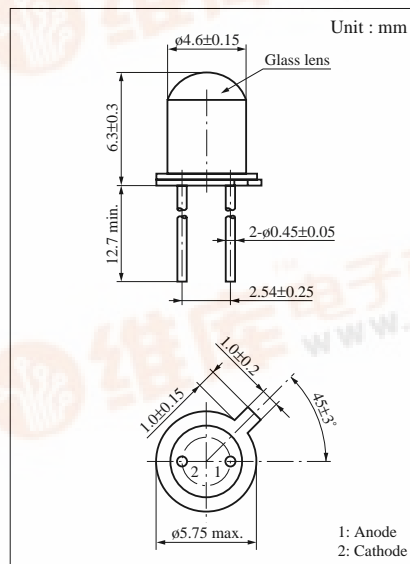

Electro-Optical Characteristics ($T_a = 25^\circ\text{C}$)

Parameter	Symbol	Conditions	min	typ	max	Unit
Radiant power	P_O	$I_F = 50\text{mA}$	6	10		mW
Peak emission wavelength	λ_p	$I_F = 50\text{mA}$		860		nm
Spectral half band width	$\Delta\lambda$	$I_F = 50\text{mA}$		40		nm
Forward voltage (DC)	V_F	$I_F = 100\text{mA}$		1.6	1.9	V
Reverse current (DC)	I_R	$V_R = 3\text{V}$			10	μA
Capacitance between pins	C_t	$V_R = 0\text{V}$, $f = 1\text{MHz}$				pF
Half-power angle	θ	The angle in which radiant intensity is 50%		6		deg.
Cutoff frequency	f_C^*	$I_{FP} = 50\text{mA} + 10\text{mA}_{p-p}$		20		MHz

* Frequency when modulation optical power decreases by 3dB from 1MHz. $\left(10 \log \frac{P_O(f_C\text{MHz})}{P_O(1\text{MHz})} = -3\right)$



