

LOW-POWER DIFFERENTIAL COMPARATORS WITH STROBES

SLCS003A – JUNE 1987 – REVISED MAY 1988

- **Low Power Drain . . . 900 μ W Typical With 5-V Supply**
- **Operates From ± 15 V or From a Single Supply as Low as 3 V**
- **Output Drive Capability of 25 mA**
- **Emitter Output Can Swing Below Negative Supply**
- **Response Time . . . 1.2 μ s Typ**
- **Low Input Currents:**
 Offset Current . . . 2 nA Typ
 Bias Current . . . 15 nA Typ
- **Wide Common-Mode Input Range:**
 – 14.5 V to 13.5 V Using ± 15 -V Supply
- **Same Pinout as LM111, LM211, LM311**
- **Designed to Be Interchangeable With National Semiconductor LP311**

description

The LP111, LP211, LP311 are low-power versions of the industry standard LM111, LM211, LM311. They take advantage of stable, high-value, ion-implanted resistors to perform the same function as the LM311 series, with a 30:1 reduction in power consumption but only a 6:1 slowdown in response time. They are well suited for battery-powered applications and all other applications where fast response times are not needed. They operate over a wide range of supply voltages, from ± 18 V down to a single 3-V supply with less than 300- μ A current drain, but are still capable of driving a 25-mA load. The LP111, LP211, and LP311 are quite easy to apply free of oscillation if ordinary precautions are taken to minimize stray coupling from the output to either input or to the trim pins.

The LP111 is characterized for operation over the full military temperature range of -55°C to 125°C . The LP211 is characterized for operation from -25°C to 85°C , and the LP311 is characterized for operation from 0°C to 70°C .

LP111 . . . JG PACKAGE
 LP211, LP311 . . . D, JG, OR P PACKAGE
 (TOP VIEW)

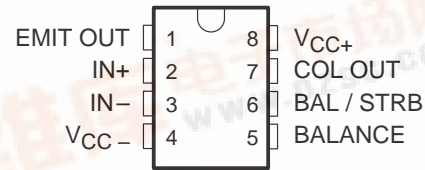

LP111 . . . FK PACKAGE
 (TOP VIEW)

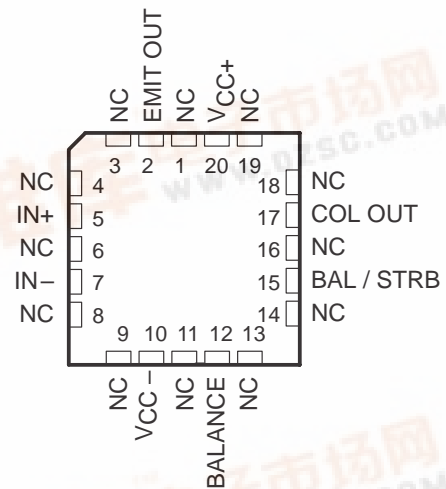

NC – No internal connection

functional block diagram

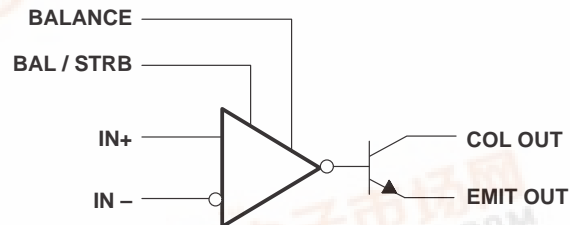

AVAILABLE OPTIONS

T _A	V _{IOmax} AT 25°C	PACKAGE			
		SMALL OUTLINE (D)	CERAMIC (FK)	CERAMIC DIP (JG)	PLASTIC DIP (P)
0°C to 70°C	7.5 mV	LP311D	—	LP311JG	LP311P
-25°C to 85°C	7.5 mV	LP211D	—	LP211JG	LP211P
-55°C to 125°C	7.5 mV	—	LP111FK	LP111JG	—



LP111, LP211, LP311

LOW-POWER DIFFERENTIAL COMPARATORS WITH STROBES

SLCS003A – JUNE 1987 – REVISED MAY 1988

absolute maximum ratings over operating free-air temperature range (unless otherwise noted)†

Supply voltage, V_{CC+} (see Note 1)	18 V
Supply voltage, V_{CC-} (see Note 1)	- 18 V
Differential input voltage, V_{ID} (see Note 2)	± 30 V
Input voltage, V_I (either input, see Notes 1 and 3)	± 15 V
Voltage from emitter output to V_{CC-}	30 V
Voltage from collector output to V_{CC-}	40 V
Voltage from collector output to emitter output	40 V
Duration of output short circuit (see Note 4)	40 V
Continuous total dissipation	See Dissipation Rating Table
Operating free-air temperature range, T_A : LP111	- 55°C to 125°C
LP211	- 25°C to 85°C
LP311	0°C to 70°C
Storage temperature range	- 65°C to 150°C
Lead temperature range 1,6 mm (1/16 inch) from case for 10 seconds: D or P package	260°C
Case temperature for 60 seconds: FK package	260°C
Lead temperature range 1,6 mm (1/16 inch) from case for 60 seconds: JG package	300°C

† Stresses beyond those listed under absolute maximum ratings may cause permanent damage to the device. These are stress ratings only, and functional operation of the device at these or any other conditions beyond those indicated in the recommended operating conditions section of this specification is not implied. Exposure to absolute-maximum-rated conditions for extended periods may affect device reliability.

- NOTES:
1. All voltage values, unless otherwise noted, are with respect to the midpoint between V_{CC+} and V_{CC-} .
 2. Differential input voltages are at $IN+$ with respect to $IN-$.
 3. The magnitude of the input voltage must never exceed the magnitude of the supply voltage of ± 15 V, whichever is less.
 4. The output may be shorted to ground or to either power supply.

DISSIPATION RATING TABLE

PACKAGE	$T_A \leq 25^\circ\text{C}$ POWER RATING	DERATING FACTOR	DERATE ABOVE T_A	$T_A = 70^\circ\text{C}$ POWER RATING	$T_A = 85^\circ\text{C}$ POWER RATING	$T_A = 125^\circ\text{C}$ POWER RATING
D	500 mW	5.8 mW/°C	64°C	464 mW	377 mW	—
FK	1375 mW	11.0 mW/°C	25°C	880 mW	715 mW	275 mW
JG (LP111)	1050 mW	8.4 mW/°C	25°C	672 mW	546 mW	210 mW
JG (LP_11)	825 mW	6.6 mW/°C	25°C	528 mW	429 mW	—
P	500 mW	8.0 mW/°C	88°C	500 mW	500 mW	—

recommended operating conditions

	MIN	MAX	UNIT
Input voltage ($ V_{CC\pm} \leq 15$ V)	$V_{CC-} + 0.5$	$V_{CC+} - 1.5$	V
Supply voltage, $V_{CC+} - V_{CC-}$	3.5	30	V

LP111, LP211, LP311

LOW-POWER DIFFERENTIAL COMPARATORS WITH STROBES

SLCS003A – JUNE 1987 – REVISED MAY 1988

electrical characteristics at specified free-air temperature, $V_{CC\pm} = \pm 15\text{ V}$ (unless otherwise noted)

PARAMETER		TEST CONDITIONS		T_A	MIN	TYP [†]	MAX	UNIT		
V_{ID}	Input offset voltage	$R_S < 100\text{ k}\Omega$,	See Note 5	25°C		2	7.5	mV		
				Full range			10			
V_{OL}	Low-level output voltage	$V_{ID} > 10\text{ mV}$, See Note 6	$I_{OL} = 25\text{ mA}$,	25°C		0.4	1.5	V		
				Full range	$V_{CC} = 4.5\text{ V}$, $V_{ID} < -10\text{ mV}$, See Note 6	$V_{CC-} = 0$, $I_{OL} = 1.6\text{ mA}$,	LP111		0.1	0.7
							LP211, LP311		0.1	0.4
I_{IO}	Input offset current	See Note 5		25°C		2	25	nA		
				Full range			35			
I_{IB}	Input bias current			25°C		15	100	nA		
				Full range			150			
	Low-level strobe current	$V_{(\text{strobe})} = 0.3\text{ V}$, See Note 7	$V_{ID} < -10\text{ mV}$,	25°C		100	300	μA		
$I_{O(\text{off})}$	Output off-state current	$V_{ID} > 10\text{ mV}$,	$V_{CE} = 35\text{ V}$	25°C		0.2	100	nA		
A_{VD}	Large signal differential voltage amplification	$R_L = 5\text{ k}\Omega$		25°C	40	100		V/mV		
I_{CC+}	Supply current from V_{CC+}	$V_{ID} = -50\text{ V}$,	$R_L = \infty$	Full range		150	300	μA		
I_{CC-}	Supply current from V_{CC-}	$V_{ID} = 50\text{ V}$,	$R_L = \infty$	Full range		-80	-180	μA		

[†] All typical values are at $V_{CC\pm} = \pm 15\text{ V}$, $T_A = 25^\circ\text{C}$.

NOTES: 5. The offset voltages and offset currents given are the maximum values required to drive the output within 1 V of either supply with a 1-mA load. Thus, these parameters define an error band and take into account the worst-case effects of voltage gain and input impedance.

6. Voltages are with respect to EMIT OUT and V_{CC-} tied together.

7. The strobe should not be shorted to ground; it should be current driven at 100 μA to 300 μA .

switching characteristics, $V_{CC\pm} = \pm 5\text{ V}$, $T_A = 25^\circ\text{C}$ (unless otherwise noted)

PARAMETER	TEST CONDITIONS	MIN	TYP	MAX	UNIT
Response time	See Note 8		1.2		μs

NOTE 8: The response time is specified for a 100-mV input step with 5-mV overdrive.

IMPORTANT NOTICE

Texas Instruments and its subsidiaries (TI) reserve the right to make changes to their products or to discontinue any product or service without notice, and advise customers to obtain the latest version of relevant information to verify, before placing orders, that information being relied on is current and complete. All products are sold subject to the terms and conditions of sale supplied at the time of order acknowledgement, including those pertaining to warranty, patent infringement, and limitation of liability.

TI warrants performance of its semiconductor products to the specifications applicable at the time of sale in accordance with TI's standard warranty. Testing and other quality control techniques are utilized to the extent TI deems necessary to support this warranty. Specific testing of all parameters of each device is not necessarily performed, except those mandated by government requirements.

CERTAIN APPLICATIONS USING SEMICONDUCTOR PRODUCTS MAY INVOLVE POTENTIAL RISKS OF DEATH, PERSONAL INJURY, OR SEVERE PROPERTY OR ENVIRONMENTAL DAMAGE ("CRITICAL APPLICATIONS"). TI SEMICONDUCTOR PRODUCTS ARE NOT DESIGNED, AUTHORIZED, OR WARRANTED TO BE SUITABLE FOR USE IN LIFE-SUPPORT DEVICES OR SYSTEMS OR OTHER CRITICAL APPLICATIONS. INCLUSION OF TI PRODUCTS IN SUCH APPLICATIONS IS UNDERSTOOD TO BE FULLY AT THE CUSTOMER'S RISK.

In order to minimize risks associated with the customer's applications, adequate design and operating safeguards must be provided by the customer to minimize inherent or procedural hazards.

TI assumes no liability for applications assistance or customer product design. TI does not warrant or represent that any license, either express or implied, is granted under any patent right, copyright, mask work right, or other intellectual property right of TI covering or relating to any combination, machine, or process in which such semiconductor products or services might be or are used. TI's publication of information regarding any third party's products or services does not constitute TI's approval, warranty or endorsement thereof.