



LPR30

LOW DROPT VOLTAGE REGULATOR DRIVE FOR EXTERNAL N-CANNEL POWER MOSFET

- VERY LOW DROPOUT POWER MOSFET DRIVER
- HIGH PRECISION $V_{ref} = 2.5V (\pm 2\%)$
- VERY LOW CURRENT DRAIN (TYP. 2mA)
- REFERENCE OUTPUT CURRENT UP TO 20mA
- OPERATING SUPPLY VOLTAGE FROM 5V TO 30V
- MAXIMUM INPUT VOLTAGE ON-GATE PIN (N. 8) UP TO 60V
- INTERNAL CURRENT LIMIT OPERATIONAL AMPLIFIER OFFSET TRIMMED AT $50mV \pm 10mV$
- NO CAPACITOR IS NEEDED FOR STABILITY OF REFERENCE OUTPUT
- TEMPERATURE RANGE $0^{\circ}C$ TO $70^{\circ}C$

APPLICATION

- ULTRA HIGH CURRENT ULTRA LOW DROPOUT VOLTAGE REGULATOR
- CONSTANT HIGH CURRENT SOURCE

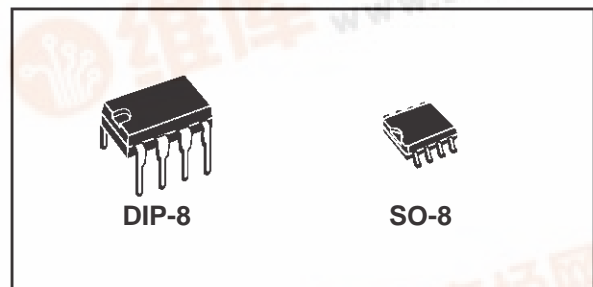

- LOW PARTS COUNT 5V TO 3.3V COMPUTER SUPPLY
- LOW NOISE/LOW DROP SMPS POST REGULATOR

DESCRIPTION

The LPR30 is a very Low Dropout Regulator Controller in a single IC solution for very high current low dropout linear voltage regulator. It uses an external N-CANNEL POWER MOSFET as the linear pass element. The LPR30 features a dropout voltage as low as the $R_{DS(on)}$ of the

BLOCK DIAGRAM

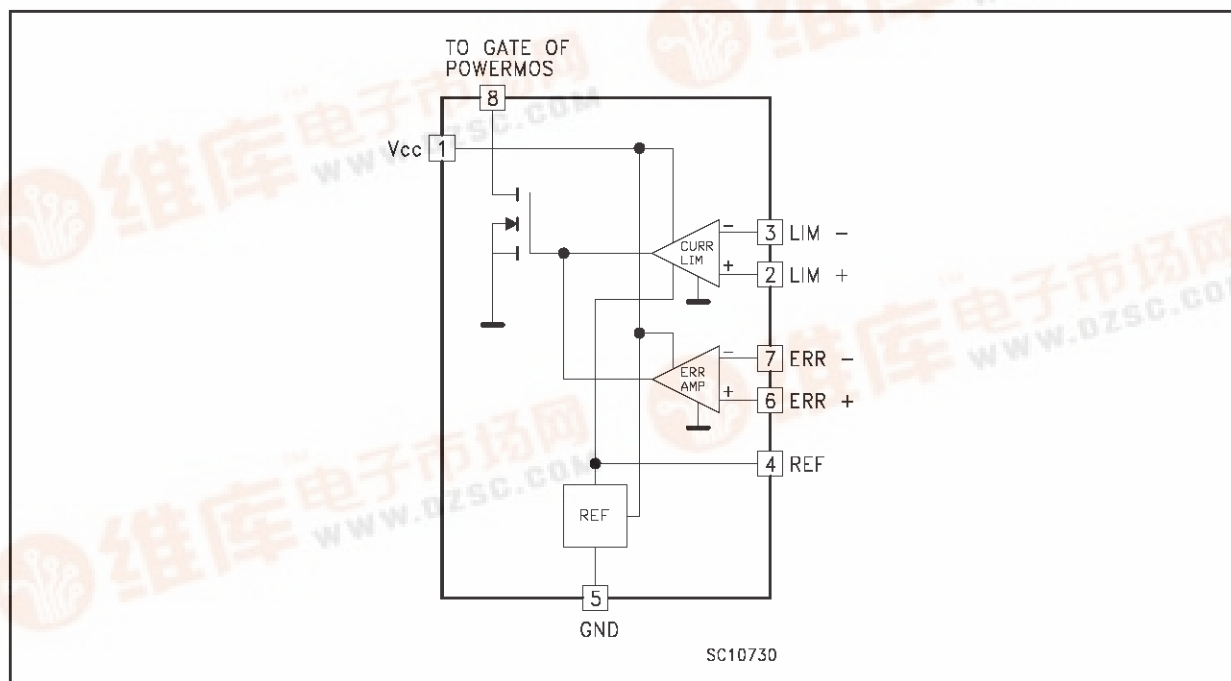

LPR30

external Power MOSFET multiplied by the output current. Consequently the output current can be as high as the POWER MOSFET can provide (also using an adequate heatsink).

The V_{CC} of the LPR30 range from 5V to 30V. For very low drop voltage operation, the LPR30 requires an external gate drive supply to provide the control voltage needed to drive the gate of the external POWER MOSFET.

The regulator output is constant-current limited when the controller detects 50mV across an external sense resistor.

It has an internal high precision ($\pm 2\%$) Voltage Reference at 2.5V

The output regulated voltage is possible to program to any voltage from 1V to more than 50V.

Flexible design is achieved by the availability of the Voltage Reference Output through an external pin (N.4) that is able to supply more than 20mA as load current. The LPR30 is available in 8 pin plastic DIP and in SO-8 for SMD. In both package versions it is able to operate from 0°C to 70°C.

ABSOLUTE MAXIMUM RATINGS

Symbol	Parameter	Value	Unit
V_{CC}	DC Input Voltage	36	V
I_{oREF}	Reference Output Current	Internally Limited	
P_{tot}	Power Dissipation	1	W
T_{op}	Operating Junction Temperature Range	0 to 70	°C
T_{stg}	Storage Temperature Range	- 40 to 150	°C
V_{gate}	Maximum Gate Voltage (pin n8)	60	V
I_{gate}	Maximum Gate Current (pin n8)	200	mA

Absolute Maximum Ratings are those values beyond which damage to the device may occur. Functional operation under these conditions is not implied.

THERMAL DATA

Symbol	Parameter	DIP-8	SO-8	Unit
$R_{thj-amb}$	Thermal Resistance Junction-ambient (*) Max	130 to 180	100 to 150	°C/W

(*) This value depends from thermal design of PCB on which the device is mounted.

CONNECTION DIAGRAM (top view)

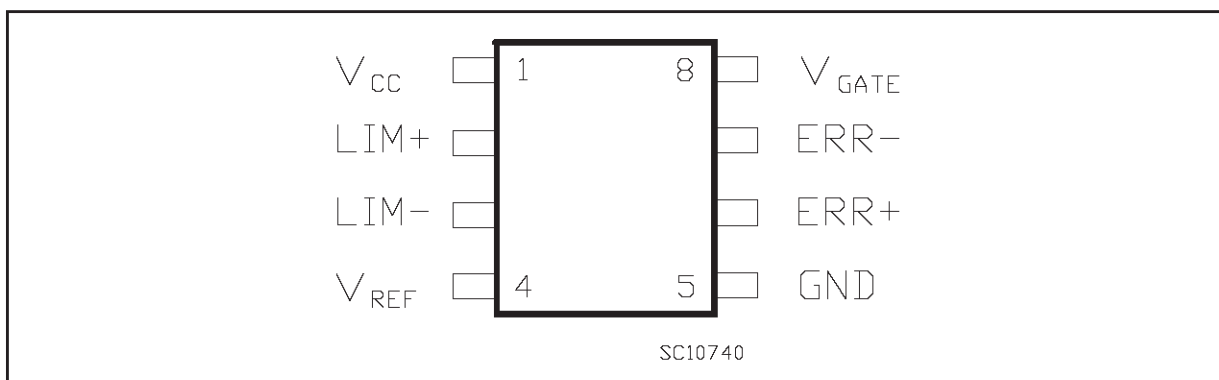

ORDERING NUMBERS

Type	DIP-8	SO-8	SO-8 (tape & reel)
LPR30	LPR30N	LPR30D	LPR30D-TR

ELECTRICAL CHARACTERISTICS(Refer to the test circuits, $V_{CC} = 10V$, $T_j = 25\text{ }^\circ\text{C}$ unless otherwise specified.)**GENERAL**

Symbol	Parameter	Test Conditions	Min.	Typ.	Max.	Unit
V_{CC}	Operating Supply Voltage		5		30	V
I_{CC}	Supply Current	$I_K = 0\ \mu\text{A}$ $V_{CC} = 30\ \text{V}$ $T_j = 0\ \text{to}\ 70\text{ }^\circ\text{C}$ ERR(-), LIM(-) = 1V ERR(+), LIM(+) = 0V		2	4	mA
V_{OSAT}	Output Saturation Voltage	$V_{CC} = 5\ \text{V}$ $I_O = 100\ \text{mA}$ $T_j = 0\ \text{to}\ 70\text{ }^\circ\text{C}$ ERR(-), LIM(-) = 1V ERR(+), LIM(+) = 0V		280	500	mV
I_{OLK}	Output Leakage Current	$V_{CC} = 5\ \text{V}$ $V_O = 60\ \text{V}$ ERR(-), LIM(-) = 0V ERR(+), LIM(+) = 1V			100	μA

REFERENCE BLOCK

Symbol	Parameter	Test Conditions	Min.	Typ.	Max.	Unit
V_{REF}	Reference Output Voltage		2.45	2.5	2.55	V
I_K	Reference Output Current		20			mA
$\Delta V_{REF}/\Delta I_K$	Reference Output Voltage Change	$I_K = 1\ \text{to}\ 20\ \text{mA}$ $C_{REF} = 0\ \text{pF}$		3		mV
SVR	Supply Voltage Rejection	$V_{IN} < 10\ \text{V} \pm 1\text{V}$ $f = 120\ \text{Hz}$ $C_{REF} = 0\ \text{pF}$		70		dB
eN	Output Noise	$B = 10\ \text{Hz to}\ 10\ \text{KHz}$ $I_K = 10\ \text{mA}$ $C_{REF} = 0\ \text{pF}$		50		μV

ERROR AMPLIFIER BLOCK

Symbol	Parameter	Test Conditions	Min.	Typ.	Max.	Unit
I_B	Input Bias Current			0.3	1	μA
V_{OS}	Input Offset Voltage	$V_{CC} = 5\ \text{to}\ 30\ \text{V}$ $T_j = 0\ \text{to}\ 70\text{ }^\circ\text{C}$			5	mV
I_{OS}	Input Offset Current			5	50	nA
G_V	Open Loop Gain	$T_j = 0\ \text{to}\ 70\text{ }^\circ\text{C}$	80			dB
V_{CM}	Input Common Mode Voltage Range	$T_j = 0\ \text{to}\ 70\text{ }^\circ\text{C}$	1		$V_{CC}-1$	V
CMR	Common Mode Rejection			70		dB
SVR	Supply Voltage Rejection	$V_{IN} = 9\ \text{to}\ 11\ \text{V}$ $f = 120\ \text{Hz}$ $V_{IN} = 9\ \text{to}\ 11\ \text{V}$ $f = 10\ \text{KHz}$	70 60			dB dB

CURRENT LIMITING BLOCK

Symbol	Parameter	Test Conditions	Min.	Typ.	Max.	Unit
I_B	Input Bias Current				0.5	μA
V_{OS}	Input Offset Voltage	$T_j = 0\ \text{to}\ 70\text{ }^\circ\text{C}$	40		60	V
G_V	Open Loop Gain	$T_j = 0\ \text{to}\ 70\text{ }^\circ\text{C}$	50			dB
V_{CM}	Input Common Mode Voltage Range	$T_j = 0\ \text{to}\ 70\text{ }^\circ\text{C}$	0		$V_{CC}-3$	V

LPR30

TEST CIRCUIT

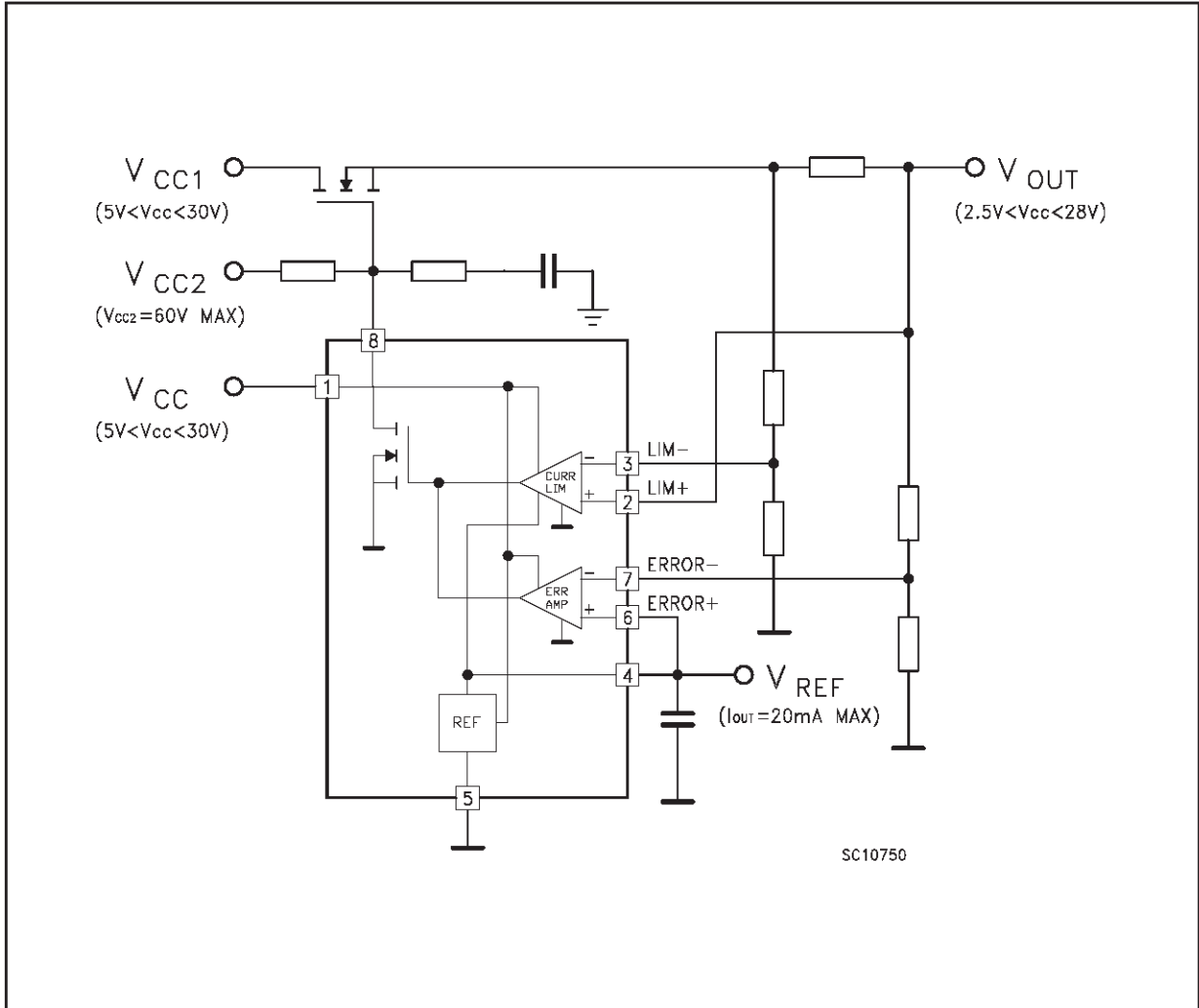

TYPICAL PERFORMANCE CHARACTERISTICS

Reference Output Voltage vs Temperature

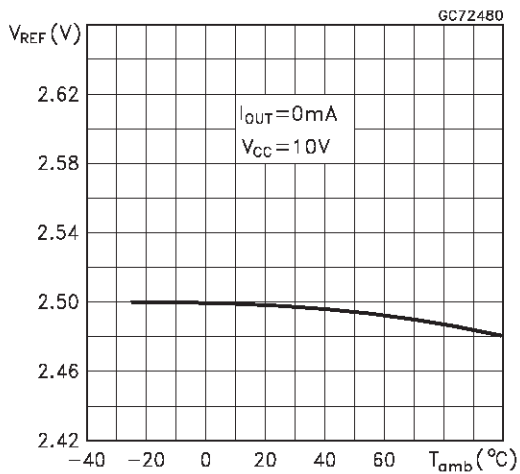

Reference Output Voltage vs Load Current

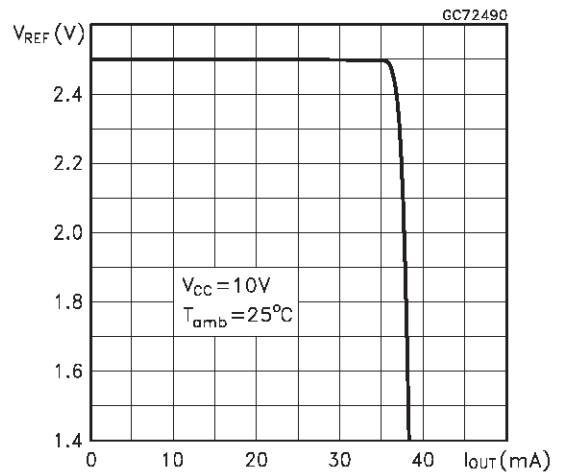

Reference Output Voltage vs Load Current

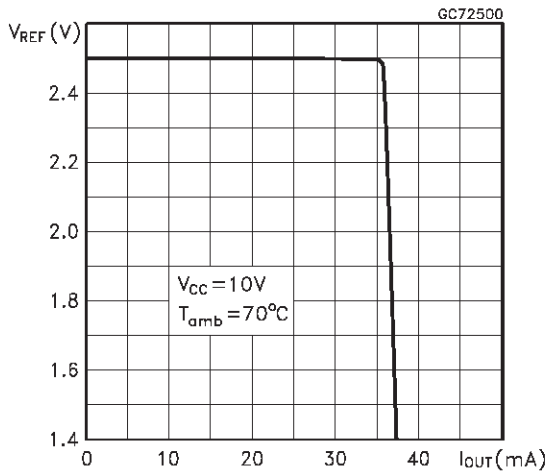

Error Amplifier Output Saturation Voltage vs Temperature

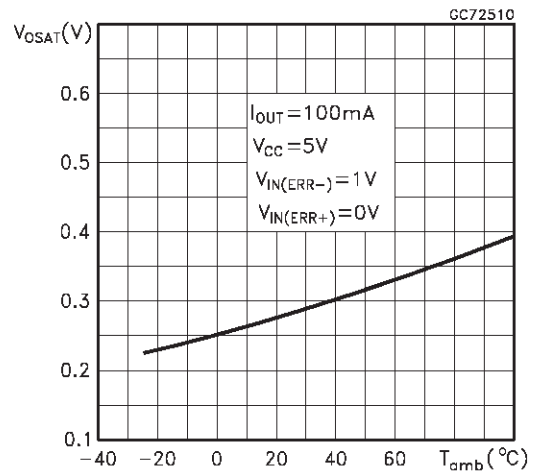

Current Limit Input Offset Voltage vs Supply Voltage

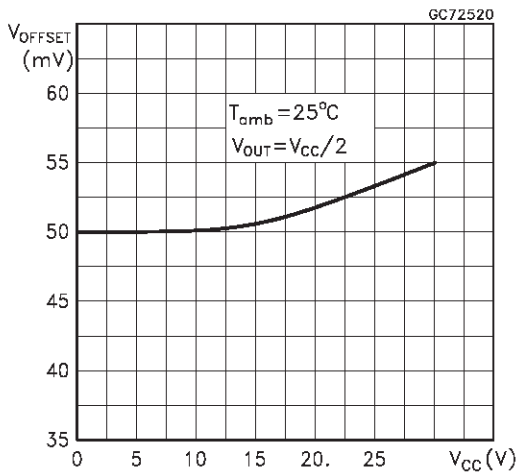

Current Limit Input Offset Voltage vs Supply Voltage

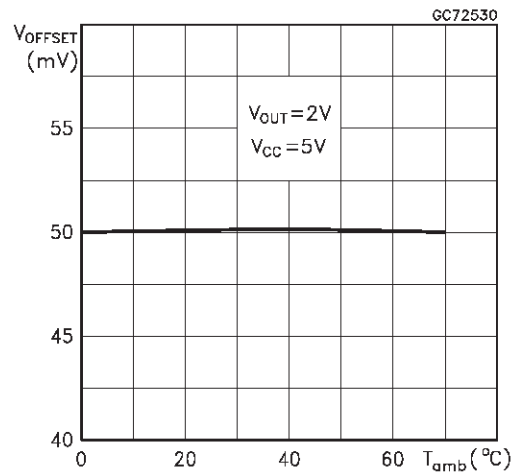

Reference Supply Voltage Rejection vs Output Current

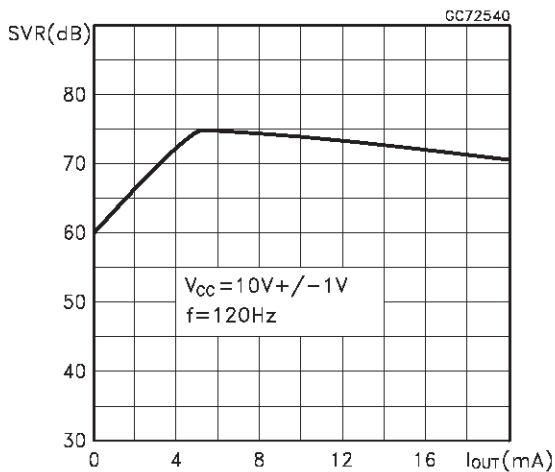

Reference Output Noise vs Output Current

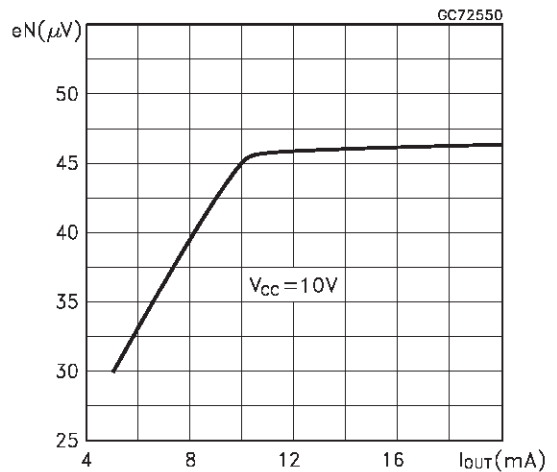

LPR30

APPLICATION INFORMATION

Figure 1: LPR30 Typical Application

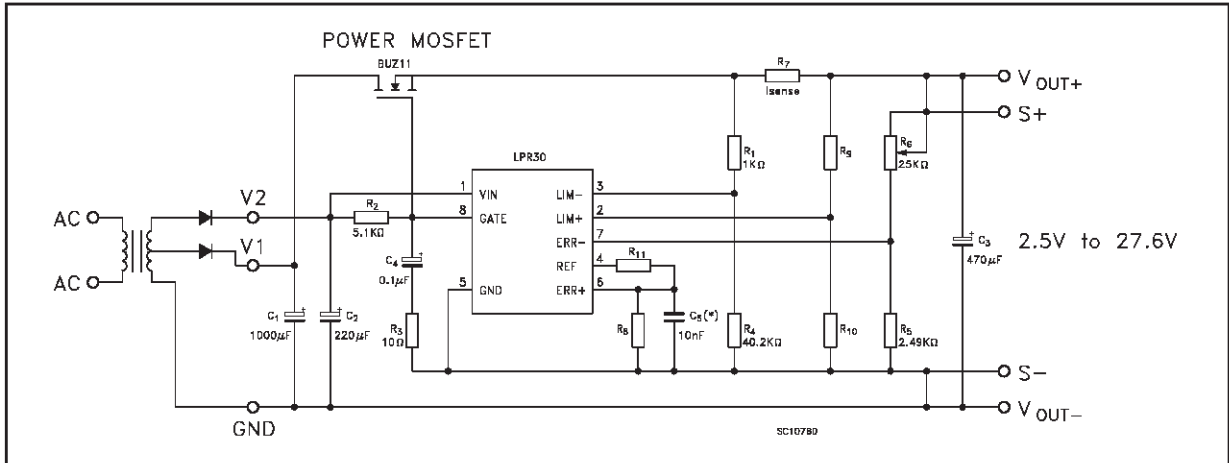

Figure 2: Configuration For Faster Response

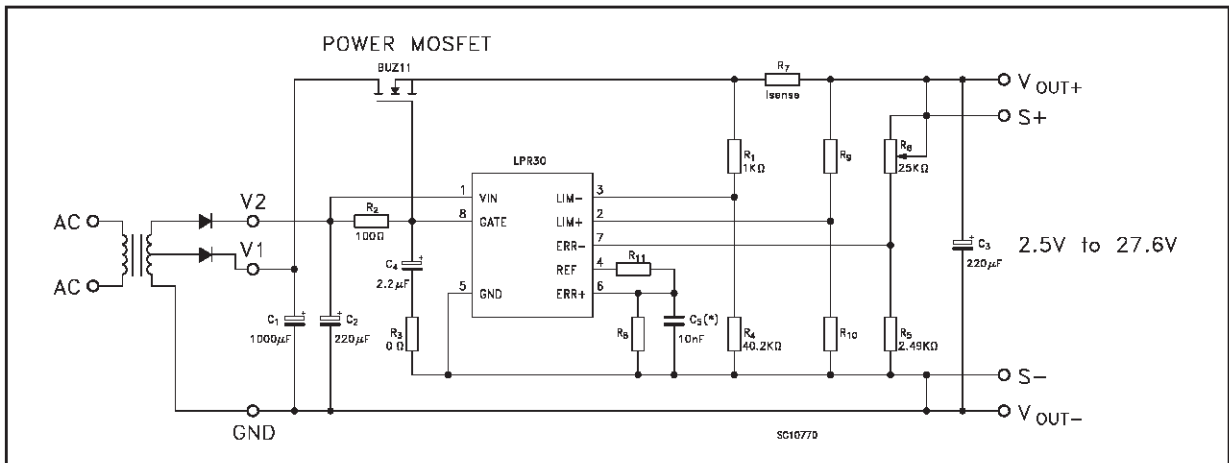
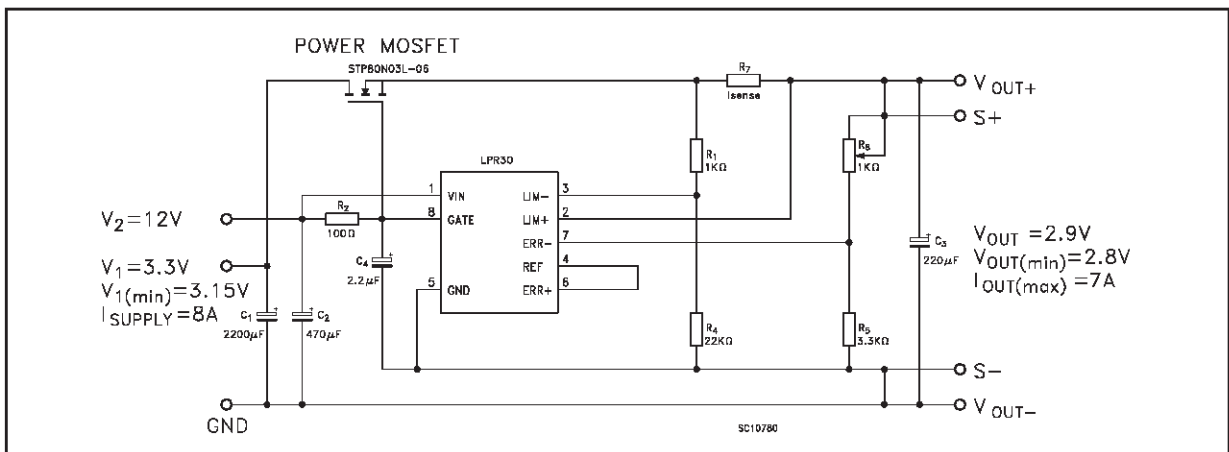

Figure 3: Configuration For $V_{IN} = 3.3V$, $V_{OUT} = 2.9V$, $I_{OUT} = 7A$



(*) This capacitor improves noise performance; can be omitted in most applications

APPLICATION INFORMATION (contiued)

Figure 4: Application For Very Fast Responce Speed

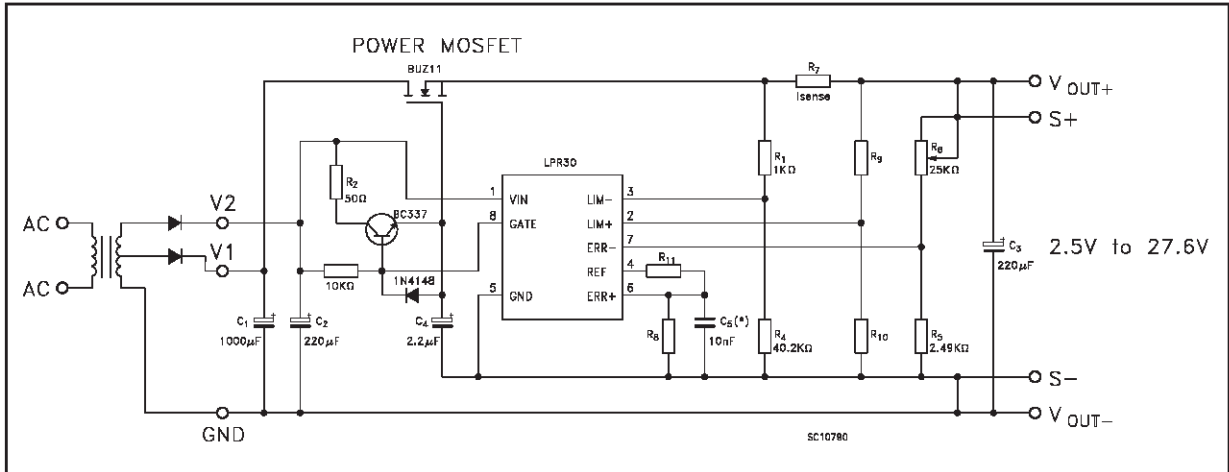

(*) This capacitor improves noise performance; can be omitted in most applications

STANDARD APPLICATION DEMOBOARD

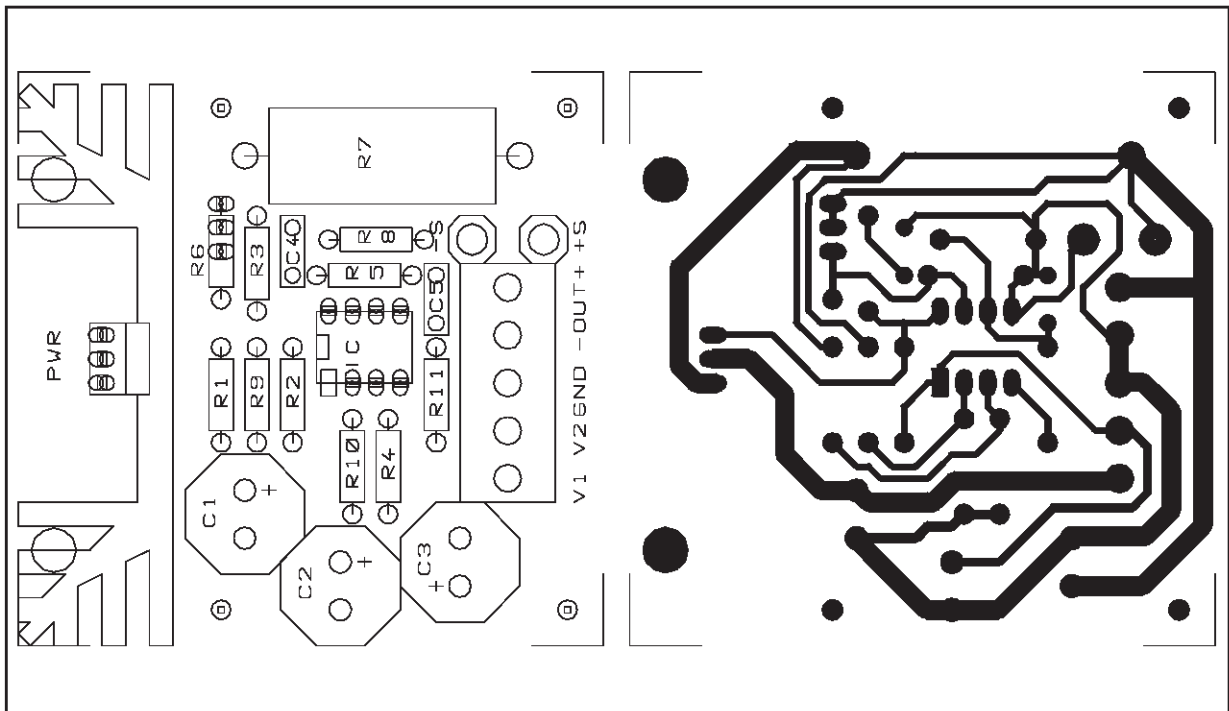

Note: This demoboard refers to the typical application shown in figure 1

Plastic DIP-8 MECHANICAL DATA

DIM.	mm			inch		
	MIN.	TYP.	MAX.	MIN.	TYP.	MAX.
A		3.3			0.130	
a1	0.7			0.028		
B	1.39		1.65	0.055		0.065
B1	0.91		1.04	0.036		0.041
b		0.5			0.020	
b1	0.38		0.5	0.015		0.020
D			9.8			0.386
E		8.8			0.346	
e		2.54			0.100	
e3		7.62			0.300	
e4		7.62			0.300	
F			7.1			0.280
I			4.8			0.189
L		3.3			0.130	
Z	0.44		1.6	0.017		0.063

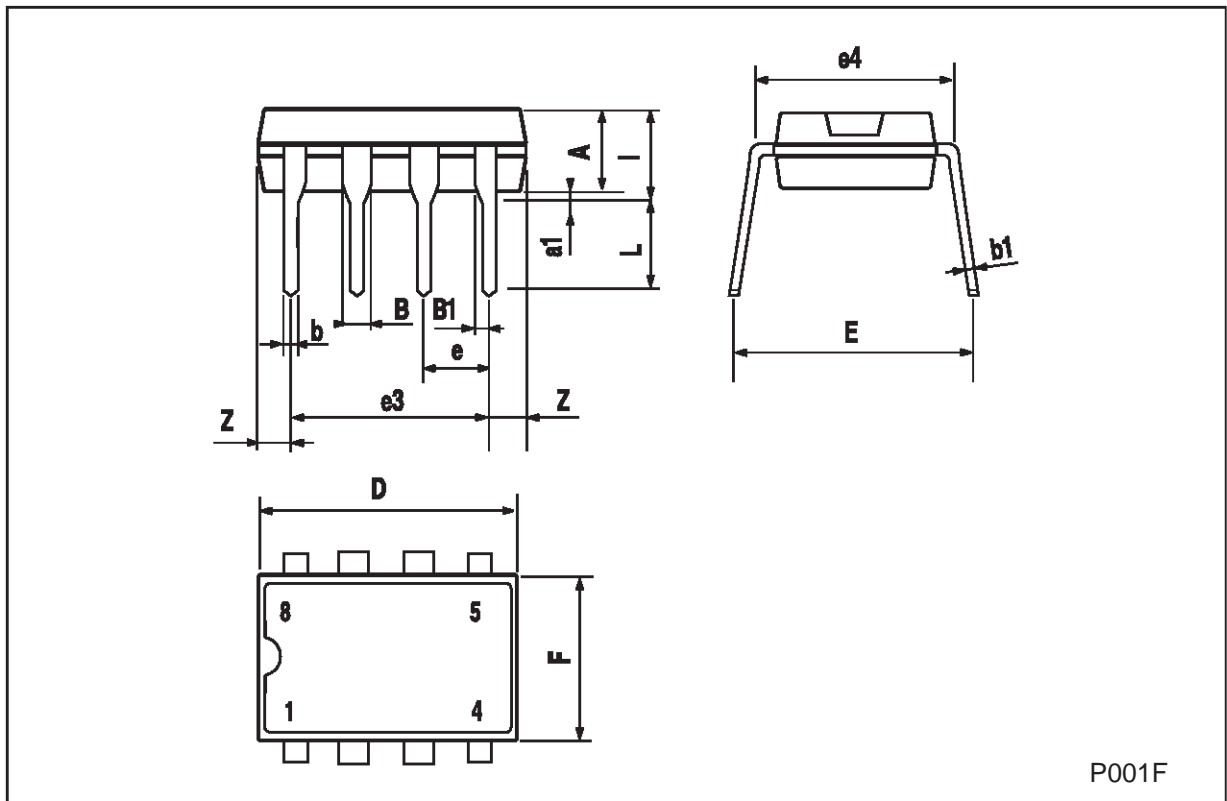

SO-8 MECHANICAL DATA

DIM.	mm			inch		
	MIN.	TYP.	MAX.	MIN.	TYP.	MAX.
A			1.75			0.068
a1	0.1		0.25	0.003		0.009
a2			1.65			0.064
a3	0.65		0.85	0.025		0.033
b	0.35		0.48	0.013		0.018
b1	0.19		0.25	0.007		0.010
C	0.25		0.5	0.010		0.019
c1	45 (typ.)					
D	4.8		5.0	0.188		0.196
E	5.8		6.2	0.228		0.244
e		1.27			0.050	
e3		3.81			0.150	
F	3.8		4.0	0.14		0.157
L	0.4		1.27	0.015		0.050
M			0.6			0.023
S	8 (max.)					

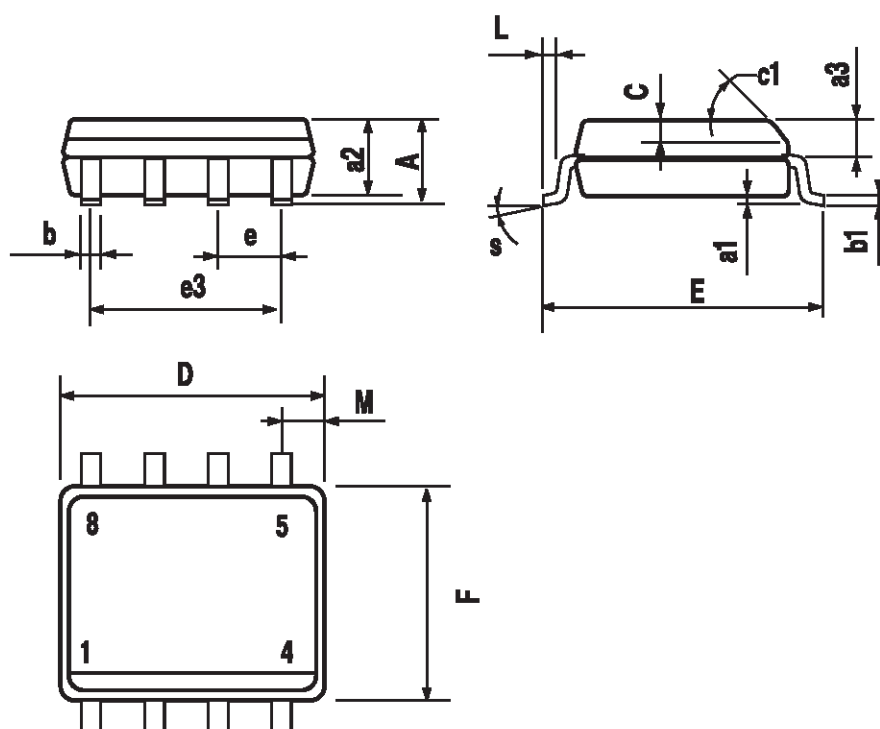

0016023

Information furnished is believed to be accurate and reliable. However, STMicroelectronics assumes no responsibility for the consequences of use of such information nor for any infringement of patents or other rights of third parties which may result from its use. No license is granted by implication or otherwise under any patent or patent rights of STMicroelectronics. Specification mentioned in this publication are subject to change without notice. This publication supersedes and replaces all information previously supplied. STMicroelectronics products are not authorized for use as critical components in life support devices or systems without express written approval of STMicroelectronics.

The ST logo is a registered trademark of STMicroelectronics

© 2000 STMicroelectronics – Printed in Italy – All Rights Reserved
STMicroelectronics GROUP OF COMPANIES

Australia - Brazil - China - Finland - France - Germany - Hong Kong - India - Italy - Japan - Malaysia - Malta - Morocco
Singapore - Spain - Sweden - Switzerland - United Kingdom - U.S.A.

<http://www.st.com>