



General Description

The LR4558 consists of two high performance operational amplifiers. The IC features high gain, high input resistance, excellent channel separation, wide range of operating voltage and internal frequency compensation. It can work with $\pm 18V$ maximum power supply voltage.

The LR4558 is specifically suitable for applications in differential-in, differential-out as well as in potential-metric amplifiers and where gain and phase matched channels are mandatory.

The LR4558 is available in DIP-8 or SOIC-8 package.

Features

- Internal Frequency Compensation
- Large DC Voltage Gain with 100 dB Typical
- High Input Resistance with $5M\Omega$ Typical
- Maximum Power Supply Voltages: $\pm 18V$

Applications

- Audio AC-3 Decoder System
- Audio Amplifier

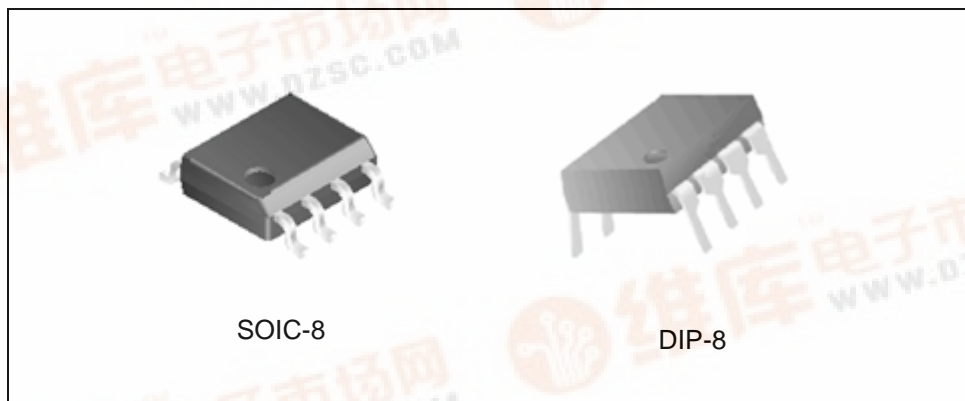
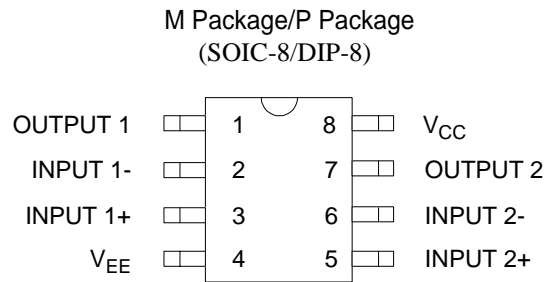

Figure 1. Package Types of LR4558

Pin Configuration



Top View

Figure 2. Pin Configuration of LR4558

Functional Block Diagram

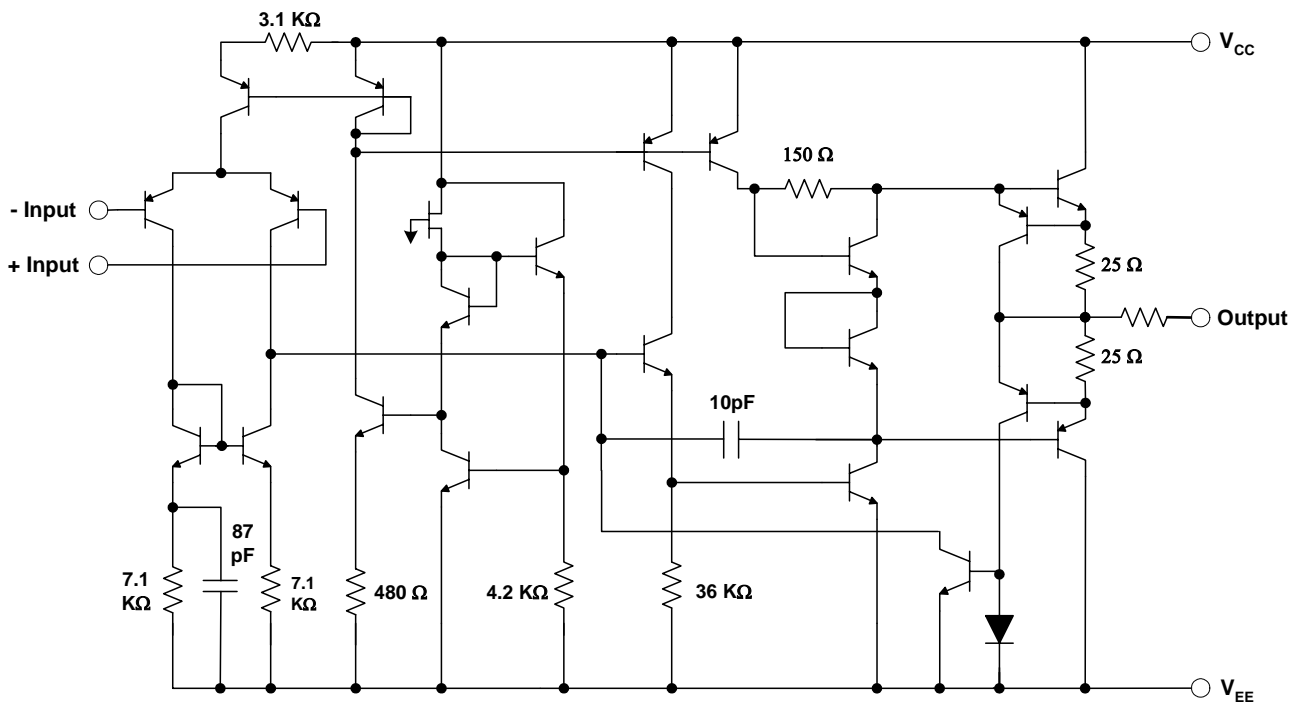

Figure 3. Representative Schematic Diagram of LR4558 (Each amplifier)

Absolute Maximum Ratings

Parameter	Symbol	Value	Unit
Power Supply Voltage	V_{CC}	+ 22	V
	V_{EE}	- 22	
Differential Input Voltage	V_{ID}	± 18	V
Input Voltage	V_{IC}	± 15	V
Operating Temperature Range	T_{OP}	-40 to 85	$^{\circ}C$
Storage Temperature Range	T_{STG}	-65 to 150	$^{\circ}C$

Electrical Characteristics

Parameter	Conditions	Min	Typ	Max	Unit
Input Offset Voltage			2	6.0	mV
Input Bias Current	$V_{CM} = 0V$		30	500	nA
Input Offset Current	$V_{CM} = 0V$		5	200	nA
Supply Current	$R_L = \infty$, Over full temperature range		3.5	5.6	mA
Large Signal Voltage Gain	$R_L < 2K$, $V_{O(P-P)} = 10V/-10V$		20	200	V/mV
Common Mode Rejection Ratio	$R_s < 10K?$		70	90	dB
Power Supply Rejection Ratio	$R_s < 10K?$		76	90	dB
Output Voltage Swing	$R_L \geq 2K\Omega$	± 10	± 13		V
	$R_L \geq 10K\Omega$	± 12	± 14		

Typical Performance Characteristics

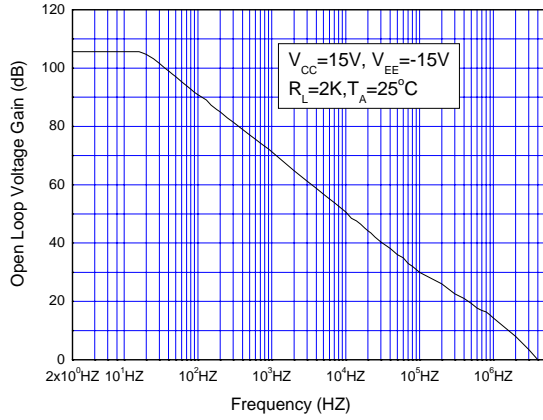

Figure 4. Open Loop Voltage Gain vs. Frequency

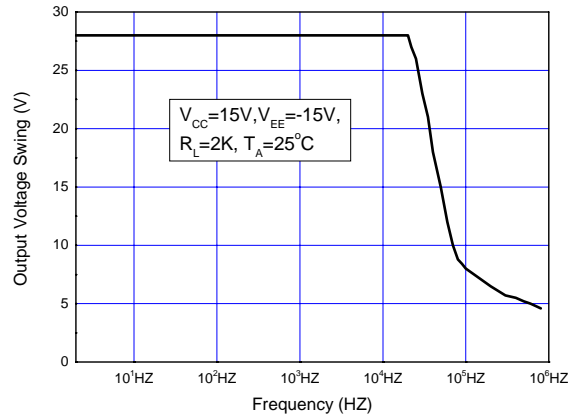

Figure 5. Maximum Output Voltage Swing vs. Frequency

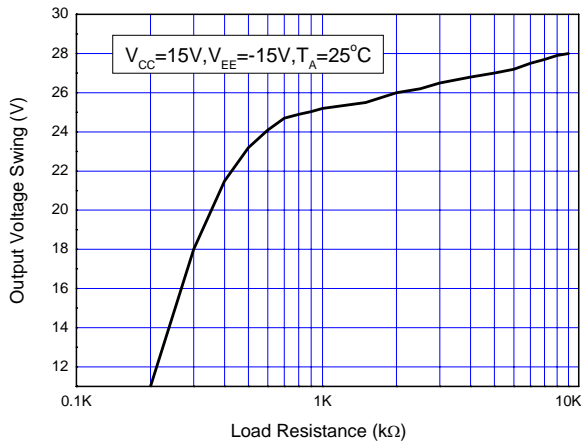

Figure 6. Maximum Output Voltage Swing vs. Load Resistance

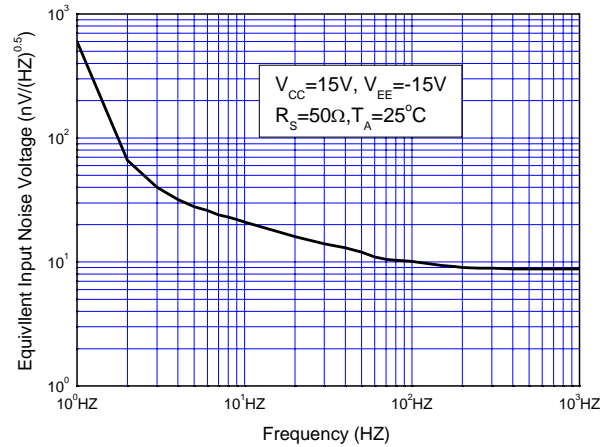

Figure 7. Equivalent Input Noise Voltage vs. Frequency

Typical Performance Characteristics (Continued)

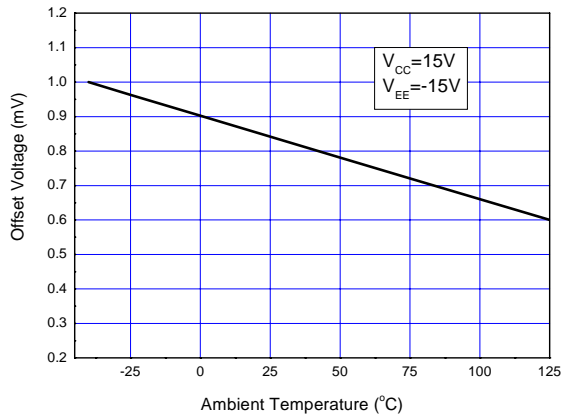

Figure 8. Input Offset Voltage vs. Temperature

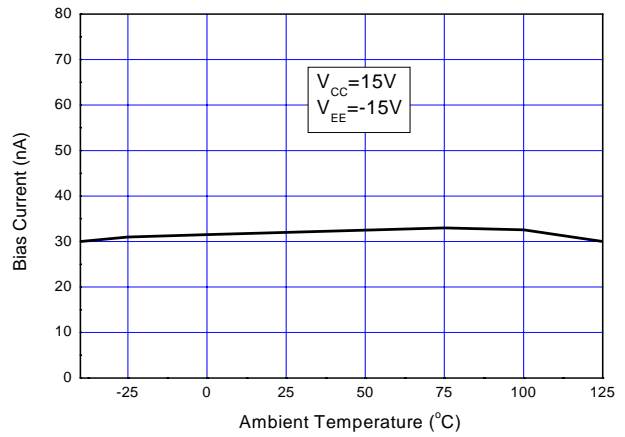

Figure 9. Input Bias Current vs. Temperature

Typical Application

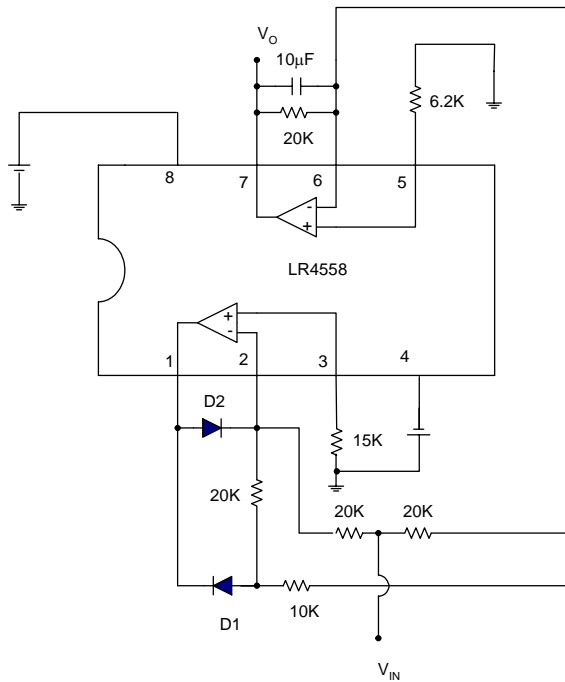
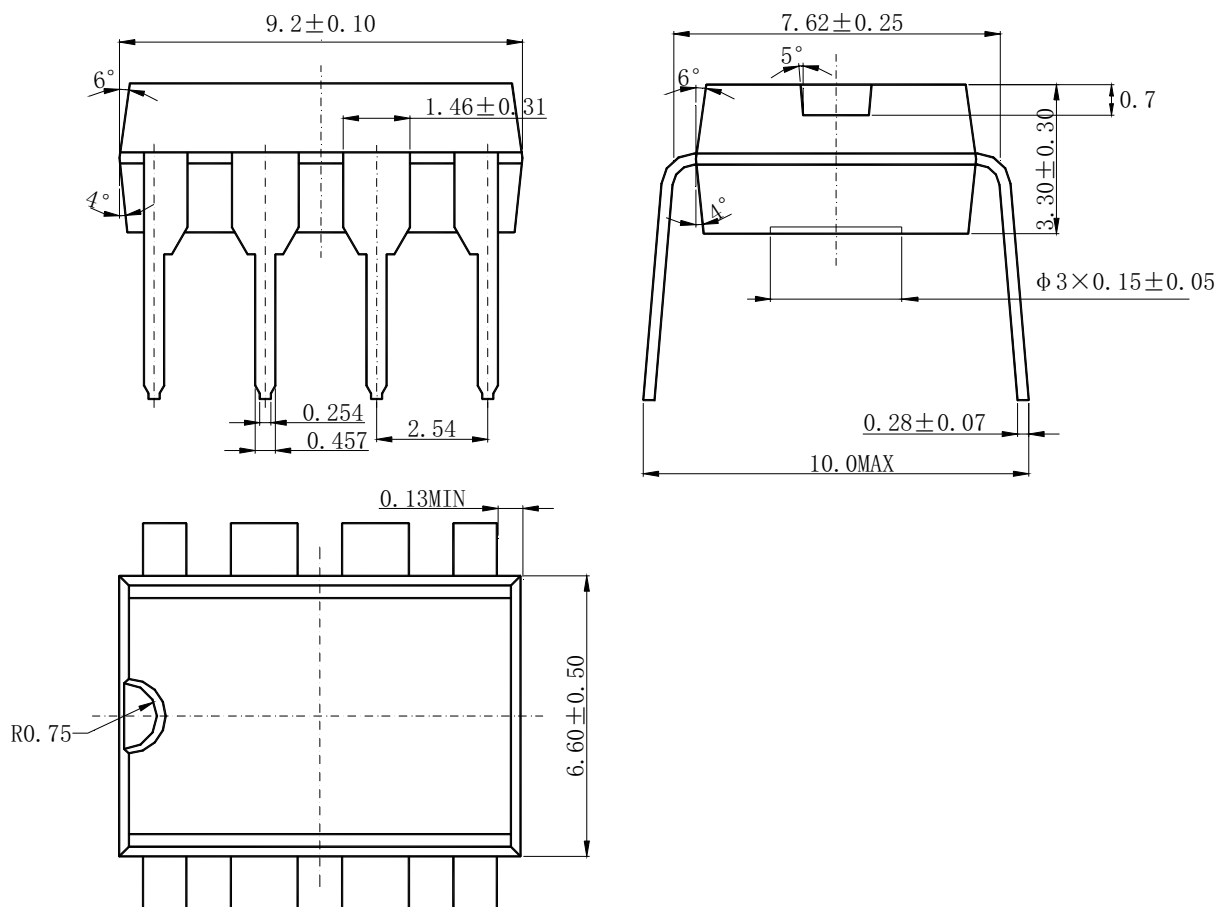

Figure 10. Application of LR4558 in an AC/DC Converter

Mechanical Dimensions**DIP - 8****Unit: mm**

Mechanical Dimensions (Continued)

SOIC - 8

Unit: mm

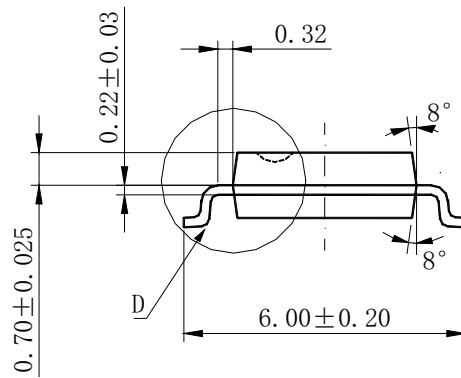
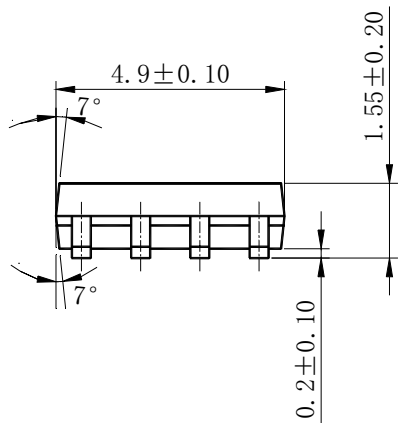

D
20:1

