

LINEAR SYSTEMS

Linear Integrated Systems

LS-U401 - U406

LOW NOISE LOW DRIFT
MONOLITHIC DUAL N-CHANNEL JFET

FEATURES		
LOW DRIFT	$ V_{GS1-2}/T = 10\mu V/^{\circ}C$ TYP.	
LOW NOISE	$e_n = 6nV/\text{Hz}$ @10Hz TYP.	
LOW PINCHOFF	$V_p = 2.5V$ TYP.	
ABSOLUTE MAXIMUM RATINGS NOTE 1		
@ 25°C (unless otherwise noted)		
Maximum Temperatures		
Storage Temperature	-65° to +150°C	
Operating Junction Temperature	+150°C	
Maximum Voltage and Current for Each Transistor NOTE 1		
-V _{GSS}	Gate Voltage to Drain or Source	50V
-V _{DSO}	Drain to Source Voltage	50V
-I _{G(f)}	Gate Forward Current	10mA
Maximum Power Dissipation		
Device Dissipation @ Free Air - Total		300mW

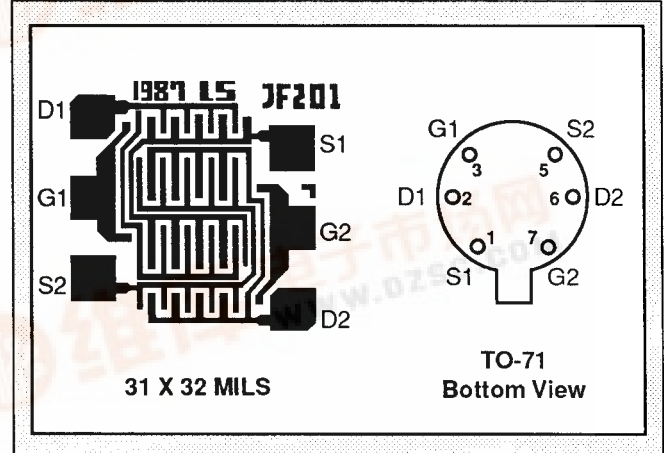

MATCHING CHARACTERISTICS @ 25°C (unless otherwise noted)

SYMBOL	CHARACTERISTICS	LS-401	LS-402	LS-403	LS-404	LS-405	LS-406	UNITS	CONDITIONS
$ V_{GS1-2}/T $ max.	Drift vs. Temperature	10	10	25	25	40	80	$\mu V/^{\circ}C$	$V_{DG} = 10V, I_D = 200\mu A$ $T_A = -55^{\circ}C$ to $+125^{\circ}C$
$ V_{GS1-2} $ max.	Offset Voltage	5	10	10	15	20	40	mV	$V_{DG} = 10V, I_D = 200\mu A$

ELECTRICAL CHARACTERISTICS

SYMBOL	CHARACTERISTICS	MIN.	TYP.	MAX.	UNITS	CONDITIONS
BV _{GSS}	Breakdown Voltage	50	60	--	V	$V_{DS} = 0, I_D = 1nA$
BV _{GGO}	Gate-to-Gate Breakdown	± 50	--	--	V	$I_G = 1nA, I_D = 0, I_S = 0$
<u>TRANSCONDUCTANCE</u>						
Y _{fss}	Full Conduction	2000	--	7000	μmho	$V_{DG} = 10V, V_{GS} = 0, f = 1kHz$
Y _{fs}	Typical Operation	1000	--	2000	μmho	$V_{DG} = 15V, I_D = 200\mu A, f = 1kHz$
$ Y_{fs1-2}/Y_{fs} $	Mismatch	--	0.6	3	%	
<u>DRAIN CURRENT</u>						
I _{DSS}	Full Conduction	0.5	--	10	mA	$V_{DG} = 10V, V_{GS} = 0$
$ I_{DSS1-2}/I_{DSS} $	Mismatch at Full Conduction	--	1	5	%	
<u>GATE VOLTAGE</u>						
V _{GS(off)} or V _p	Pinchoff Voltage	-0.5	--	-2.5	V	$V_{DS} = 15V, I_D = 1nA$
V _{GS(on)}	Operating Range	--	--	-2.3	V	$V_{DS} = 15V, I_D = 200\mu A$
<u>GATE CURRENT</u>						
-I _G max.	Operating	--	-4	-15	pA	$V_{DG} = 15V, I_D = 200\mu A$
-I _G max.	High Temperature	--	--	-10	nA	$T_A = +125^{\circ}C$
-I _{GSS} max.	At Full Conduction	--	--	100	pA	$V_{DS} = 0V$
-I _{GSS} max.	High Temperature	5	5	5	pA	$V_{DG} = 15V, T_A = +125^{\circ}C$



SYMBOL	CHARACTERISTICS	MIN.	TYP.	MAX.	UNITS	CONDITIONS
	OUTPUT CONDUCTANCE					
Y_{OSS}	Full Conduction	--	--	20	μmho	$V_{DS} = 10\text{V}$ $V_{GS} = 0$
Y_{OS}	Operating	--	0.2	2	μmho	$V_{DS} = 15\text{V}$ $I_D = 500\mu\text{A}$
	COMMON MODE REJECTION					
CMR	$-20 \log V_{GS1-2} / V_{DS} $	95	--	--	dB	$V_{DS} = 10 \text{ to } 20\text{V}$ $I_D = 30\mu\text{A}$
	NOISE					
NF	Figure	--	--	0.5	dB	$V_{DS} = 15\text{V}$ $V_{GS} = 0$ $R_G = 10\text{M}$ $f = 100\text{Hz}$ $\text{NBW} = 6\text{Hz}$
e_n	Voltage	--	20	--	nV/Hz	$V_{DS} = 15\text{V}$ $I_D = 200\mu\text{A}$ $f = 10\text{Hz}$ $\text{NBW} = 1\text{Hz}$
	CAPACITANCE					
C_{ISS}	Input	--	--	8	pF	$V_{DS} = 15\text{V}$ $I_D = 200\mu\text{A}$ $f = 1\text{MHz}$
C_{RSS}	Reverse Transfer	--	--	1.5	pF	

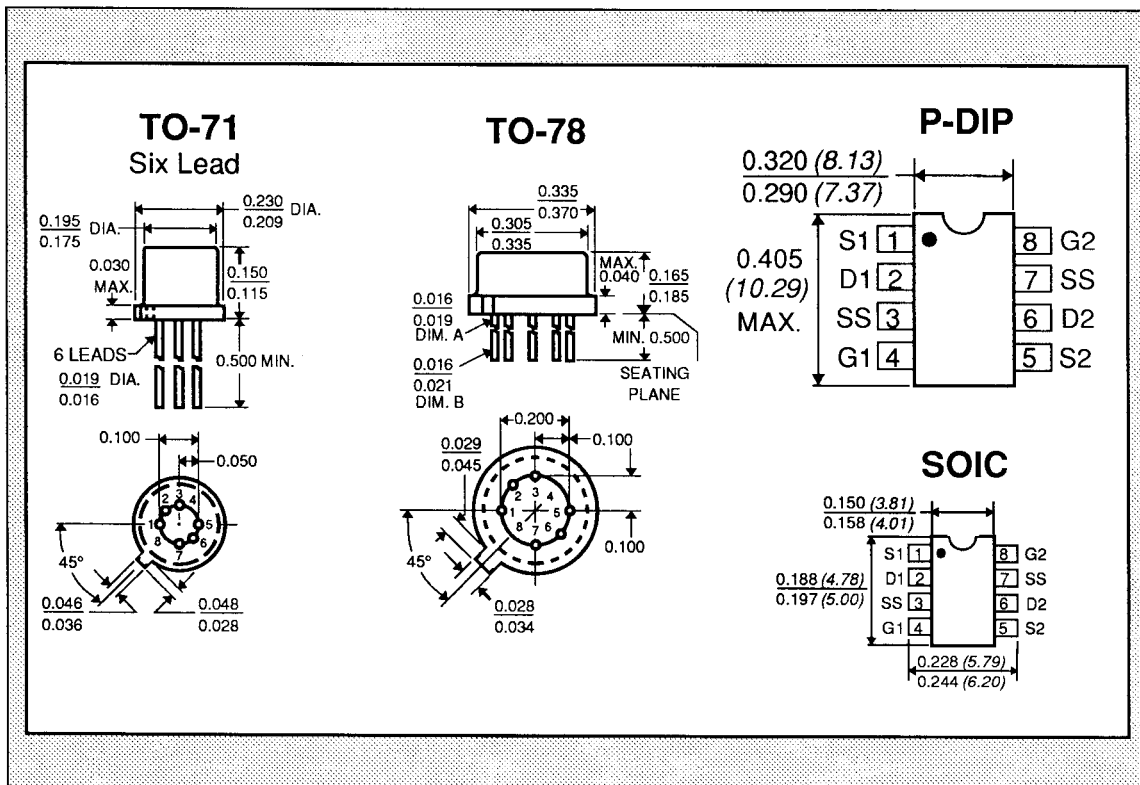

NOTES:

1. These ratings are limiting values above which the serviceability of any semiconductor may be impaired.