

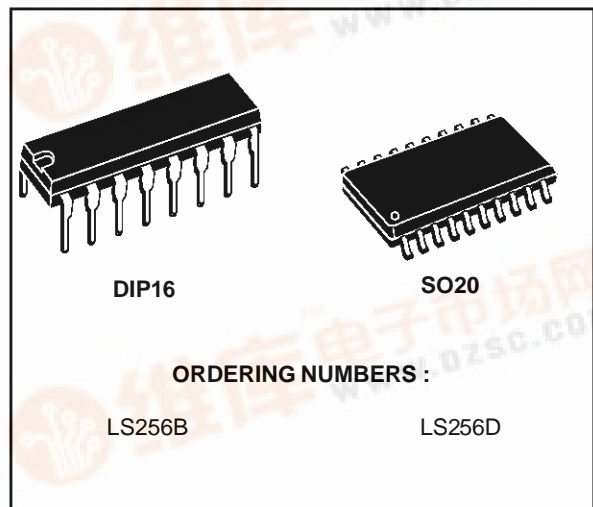

LS256

TELEPHONE SPEECH CIRCUIT WITH MULTIFREQUENCY TONE GENERATOR INTERFACE

- PRESENTS THE PROPER DC PATH FOR THE LINE CURRENT
- HANDLES THE VOICE SIGNAL, PERFORMING THE 2/4 WIRES INTERFACE AND CHANGING THE GAIN ON BOTH SENDING AND RECEIVING AMPLIFIERS TO COMPENSATE FOR LINE ATTENUATION BY SENSING THE LINE LENGTH THROUGH THE LINE CURRENT
- ACTS AS LINEAR INTERFACE FOR MF, SUPPLYING A STABILIZED TONE TO THE DIGITAL CHIP AND DELIVERING TO THE LINE THE MF TONE GENERATED BY THE DIALER



DESCRIPTION

The LS256 is a monolithic integrated circuit in 16-lead dual in-line and SO20 plastic packages to replace the hybrid circuit in telephone set. It works with the same type of transducers for both transmitter and receiver (typically piezoceramic capsules, but

the device can work also with dynamic ones). Many of its electrical characteristics can be controlled by means of external components to meet different specifications.

In addition to the speech operation, the LS256 acts as an interface for the MF tone signal.

PIN CONNECTIONS (top view)

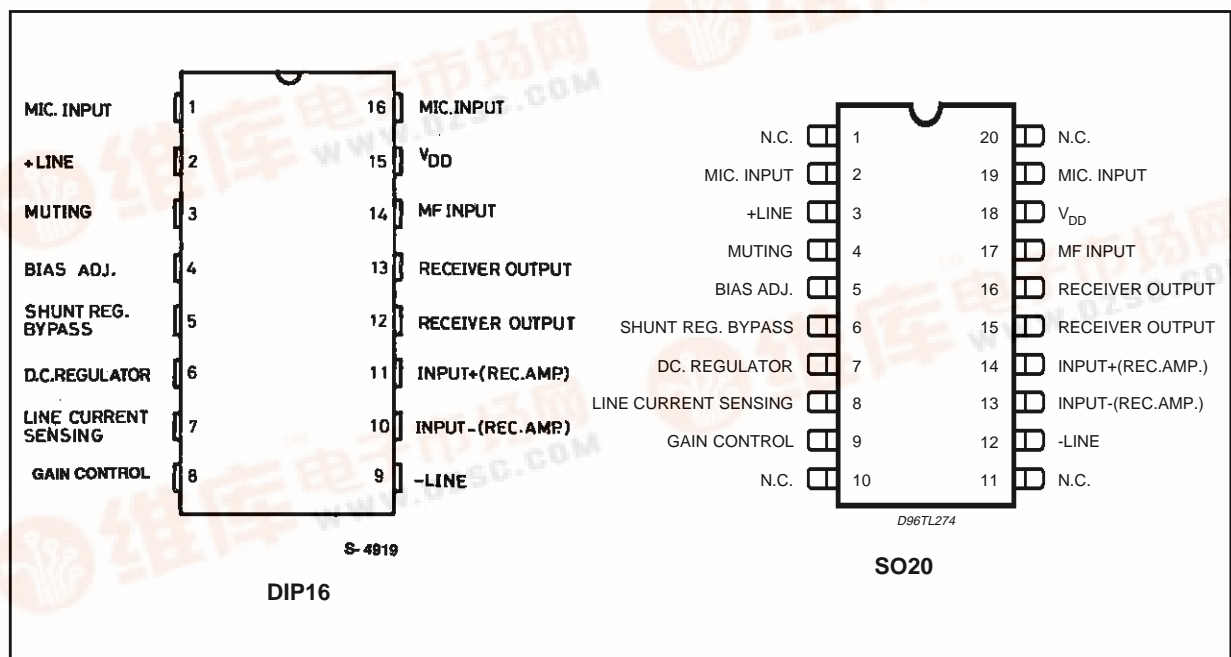

LS256

BLOCK DIAGRAM (ref. to DIP16)

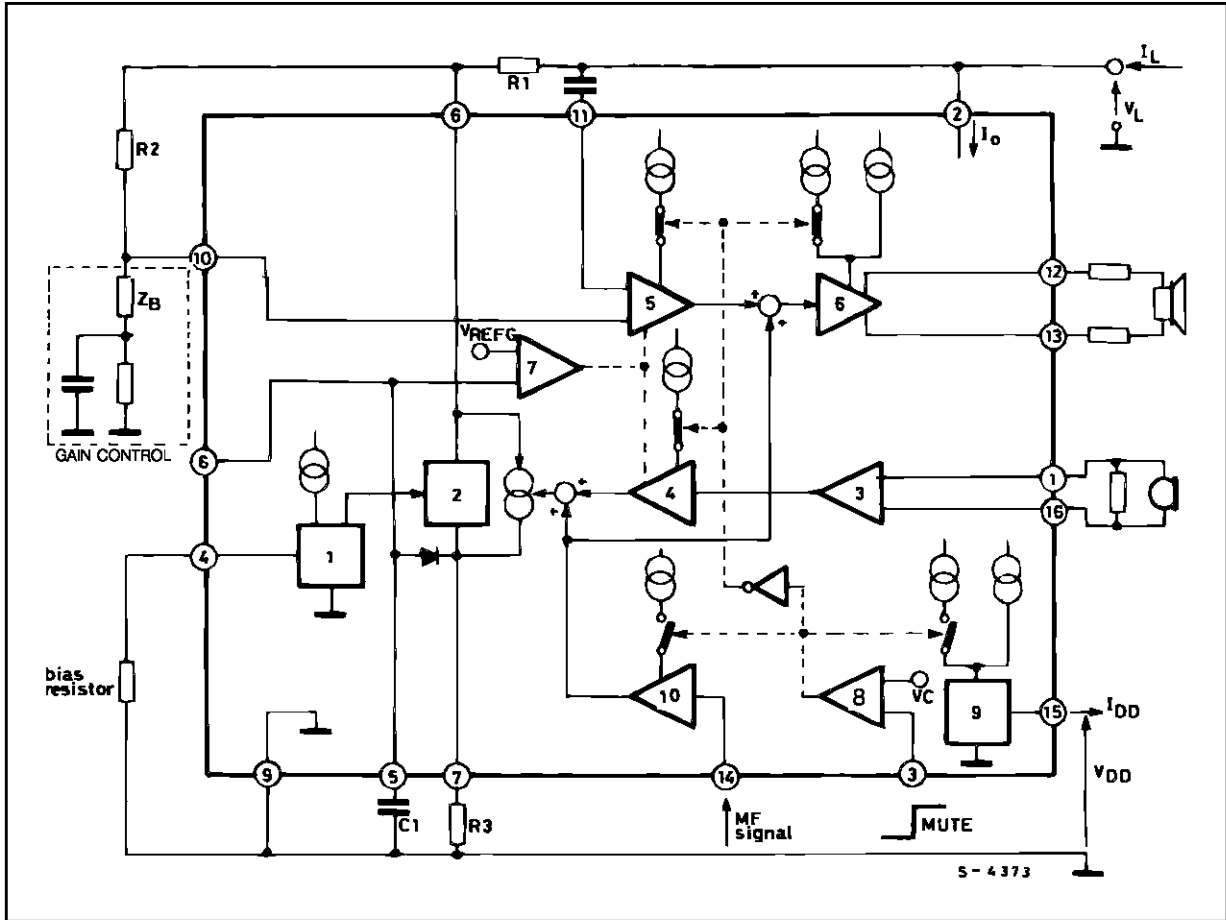

ABSOLUTE MAXIMUM RATINGS

Symbol	Parameter	Value	Unit
V_L	Line Voltage (3ms pulse duration)	22	V
I_L	Forward Line Current	150	mA
I_L	Reverse Line Current	- 150	mA
P_{tot}	Total Power Dissipation at $T_{amb} = 70^\circ\text{C}$	1	W
T_{op}	Operating Temperature	- 45 to 70	$^\circ\text{C}$
T_{stg}, T_j	Storage and Junction Temperature	- 65 to 150	$^\circ\text{C}$

THERMAL DATA

Symbol	Parameter		DIP16	SO20	Unit
$R_{th\ j-amb}$	Thermal Resistance Junction-ambient	Max	80	150	$^\circ\text{C/W}$

TEST CIRCUITS (ref. to DIP16)

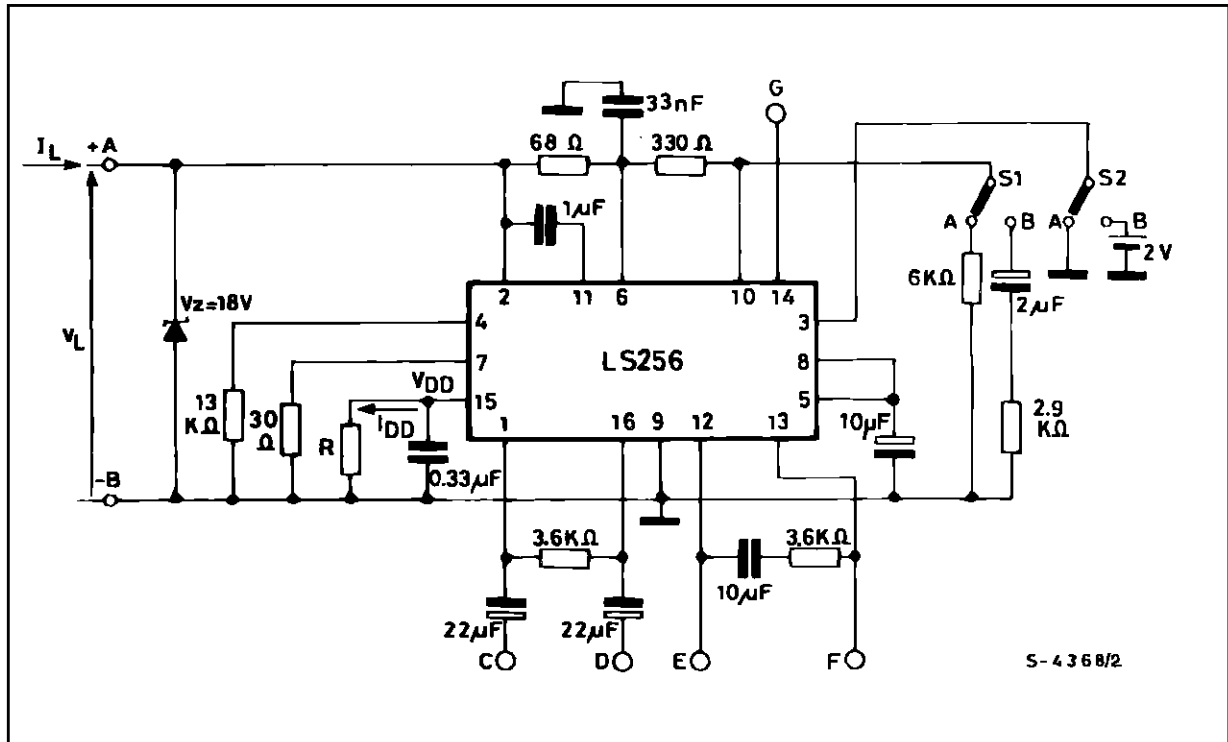

Figure 1.

Figure 2.

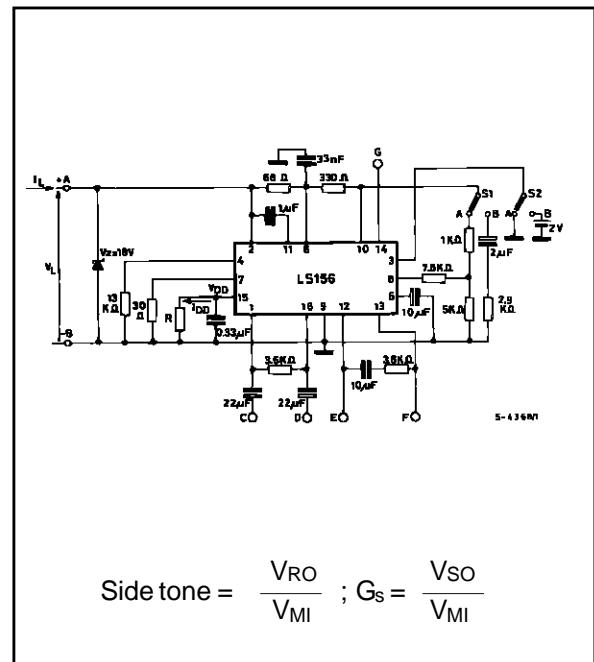
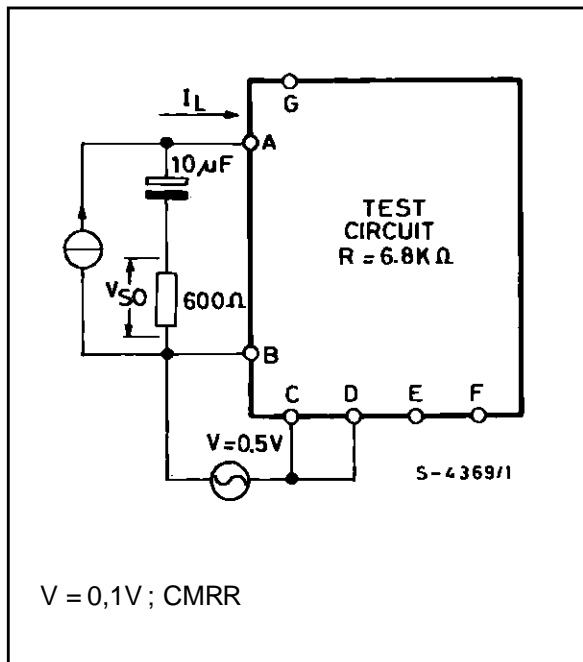

Figure 3.

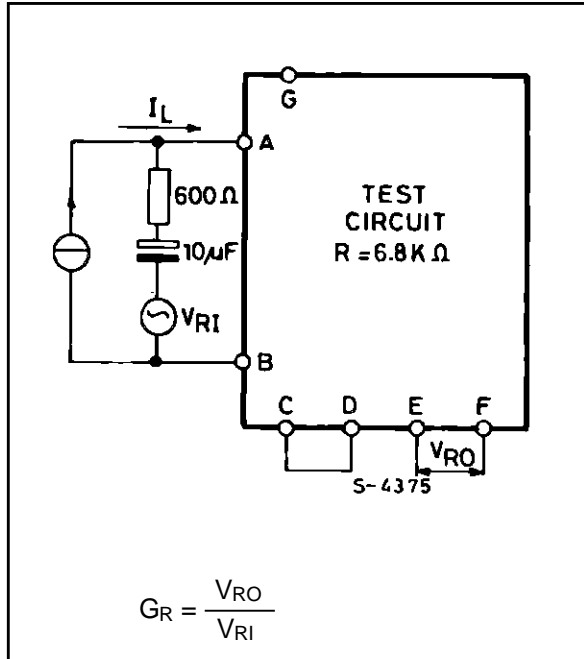
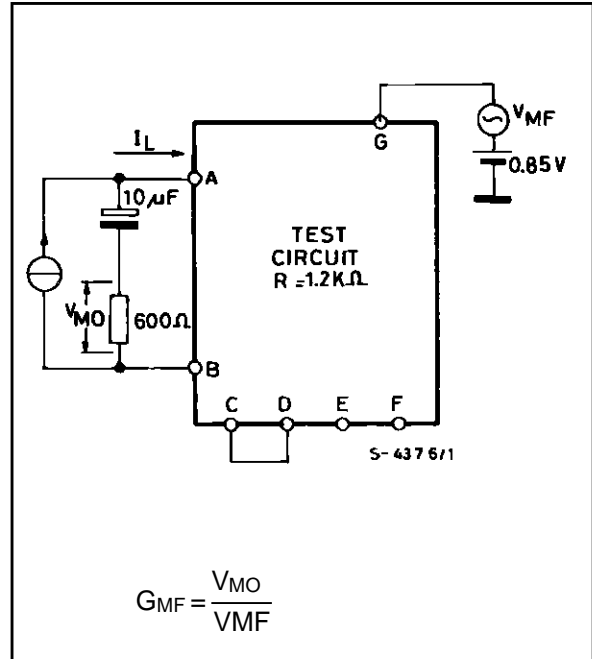

Figure 4.



ELECTRICAL CHARACTERISTICS (refer to the test circuits, S1, S2 in (a),
 $T_{amb} = -25$ to $+50^{\circ}C$, $f = 200$ to $3400Hz$, unless otherwise specified)

Symbol	Parameter	Test Conditions	Min.	Typ.	Max.	Unit	Fig.
SPEECH OPERATION							
V_L	Line Voltage	$T_{amb} = 25^{\circ}C$ $I_L = 12mA$ $I_L = 20mA$ $I_L = 80mA$	3.9		4.7 5.5 12.2	V	
CMRR	Common Mode Rejection	$f = 1kHz, I_L = 12$ to $80mA$	50			dB	1
G_S	Sending Gain	$T_{amb} = 25^{\circ}C, f = 1kHz$ $V_{MI} = 2mV$ $I_L = 52mA$ $I_L = 25mA$	44 48	45 49	46 50	dB	2
	Sending Gain Flatness	$V_{MI} = 2mV, f_{ref} = 1kHz$ $I_L = 12$ to $80mA$			± 1	dB	2
	Sending Distortion	$f = 1kHz$ $I_L = 16$ to $80mA$ $V_{SO} = 1V$ $V_{SO} = 1.3V$			2 10	%	2
	Sending Noise	$V_{MI} = 0V; I_L = 40mA; S1$ in (b)			-68.5	dBmp	2
	Microphone Input Impedance Pin 1-16	$V_{MI} = 2mV, I_L = 12$ to $80mA$	40			kΩ	
	Sending Loss in MF Operation	$V_{MI} = 2mV$ S_2 in (b) $I_L = 52mA$ $I_L = 25mA$	-30 -30			dB	2
G_R	Receiving Gain	$V_{RI} = 0.3V, f = 1kHz, T_{amb} = 25^{\circ}C$ $I_L = 52mA$ $I_L = 25mA$	2.5 7	3.5 8	4.5 9	dB	3
	Receiving Gain Flatness	$V_{RI} = 0.3V, f_{ref} = 1kHz$ $I_L = 12$ to $80mA$			± 1	dB	3
	Receiving Distortion	$f = 1kHz$ $I_L = 12mA$ $V_{RO} = 1.6V$ $I_L = 12mA$ $V_{RO} = 1.9V$ $I_L = 50mA$ $V_{RO} = 1.8V$ $I_L = 50mA$ $V_{RO} = 2.1V$			2 10 2 10	%	3
	Receiving Noise	$V_{RI} = 0V; I_L = 12$ to $80mA; S1$ in (b)		100		μV	3
	Receiver Output Impedance Pin 12-13	$V_{RO} = 50mV, I_L = 40mA$			100	Ω	

ELECTRICAL CHARACTERISTICS (continued)

Symbol	Parameter	Test Conditions	Min.	Typ.	Max.	Unit	Fig.
SPEECH OPERATION (continued)							
G_R	Sidetone	$F = 1\text{kHz}$, $T_{\text{amb}} = 25^\circ\text{C}$, S_1 in (b) $I_L = 52\text{mA}$ $I_L = 25\text{mA}$			36 36	dB	2
Z_{ML}	Line Matching Impedance	$V_{RI} = 0.3\text{V}$, $f = 1\text{kHz}$ $I_L = 12$ to 80mA	500	600	700	Ω	

MULTIFREQUENCY SYNTHESIZER INTERFACE

V_{DD}	MF Supply Voltage (standby and operation)	$I_L = 12$ to 80mA	2.4	2.5		V	
I_{DD}	MF Supply Current Stand by Operation	$I_L = 12$ to 80mA $I_L = 12$ to 80mA ; S_2 in (b)	0.5 2			mA mA	
	MF Amplifier Gain	$I_L = 12$ to 80mA , $f_{MF\text{ in}} = 1\text{kHz}$ $V_{MF\text{ in}} = 80\text{mV}$	15		17	dB	4
V_I	DC Input Voltage Level (pin 14)	$V_{M\text{ Fin}} = 80\text{mV}$		$3V_{DD}$		V	
R_I	Input Impedance (pin 14)	$V_{M\text{ Fin}} = 80\text{mV}$	40			$k\Omega$	
d	Distortion	$V_{M\text{ Fin}} = 110\text{mV}$ $I_L = 12$ to 80mA			2	%	4
	Starting Delay Time	$I_L = 12$ to 80mA			5	ms	
	Muting Threshold Voltage (pin 3)	Speech Operation			1	V	
		MF Operation	1.6			V	
	Muting Stand by Current (pin 3)	$I_L = 12$ to 80mA			- 10	μA	
	Muting Operating Current (pin 3)	$I_L = 12$ to 80mA , S_2 in (b)			+ 10	μA	

LS256

SO20 PACKAGE MECHANICAL DATA

DIM.	mm			inch		
	MIN.	TYP.	MAX.	MIN.	TYP.	MAX.
A			2.65			0.104
a1	0.1		0.3	0.004		0.012
a2			2.45			0.096
b	0.35		0.49	0.014		0.019
b1	0.23		0.32	0.009		0.013
C		0.5			0.020	
c1	45° (typ.)					
D	12.6		13.0	0.496		0.512
E	10		10.65	0.394		0.419
e		1.27			0.050	
e3		11.43			0.450	
F	7.4		7.6	0.291		0.299
L	0.5		1.27	0.020		0.050
M			0.75			0.030
S	8° (max.)					

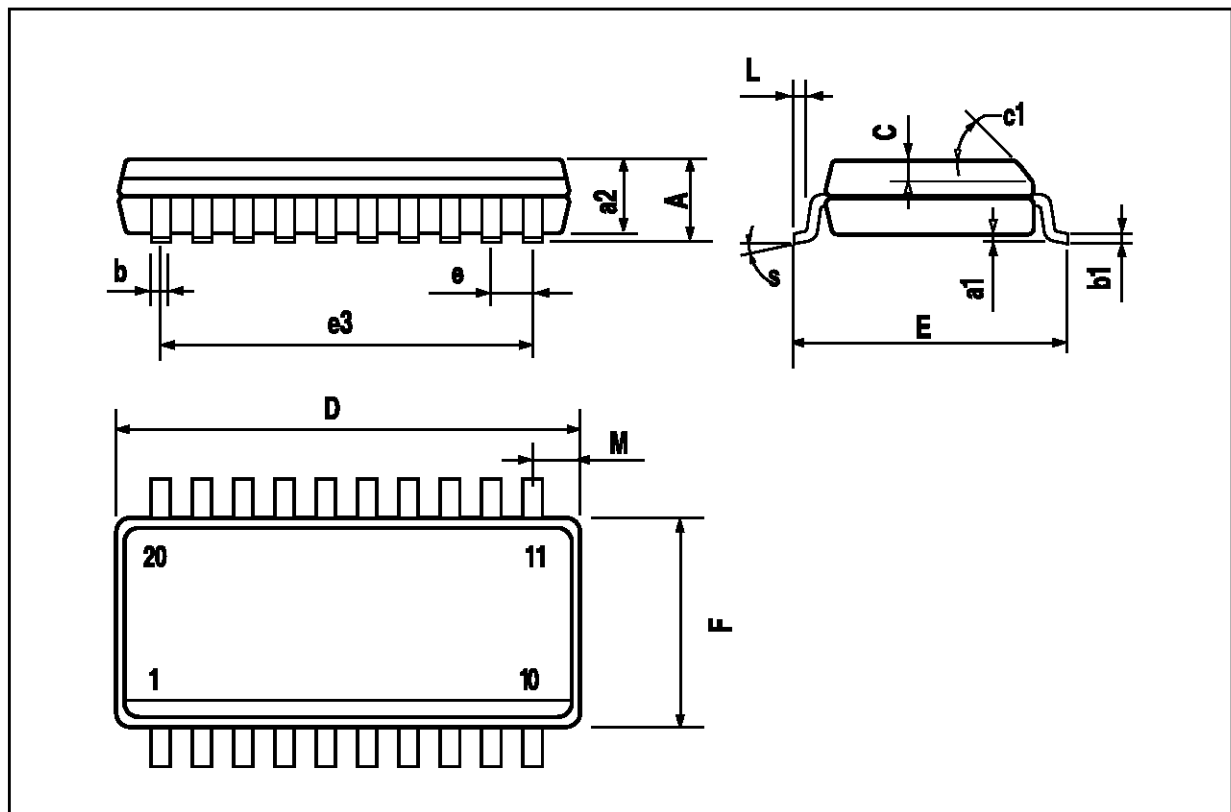

DIP16 PACKAGE MECHANICAL DATA

DIM.	mm			inch		
	MIN.	TYP.	MAX.	MIN.	TYP.	MAX.
a1	0.51			0.020		
B	0.77		1.65	0.030		0.065
b		0.5			0.020	
b1		0.25			0.010	
D			20			0.787
E		8.5			0.335	
e		2.54			0.100	
e3		17.78			0.700	
F			7.1			0.280
I			5.1			0.201
L		3.3			0.130	
Z			1.27			0.050

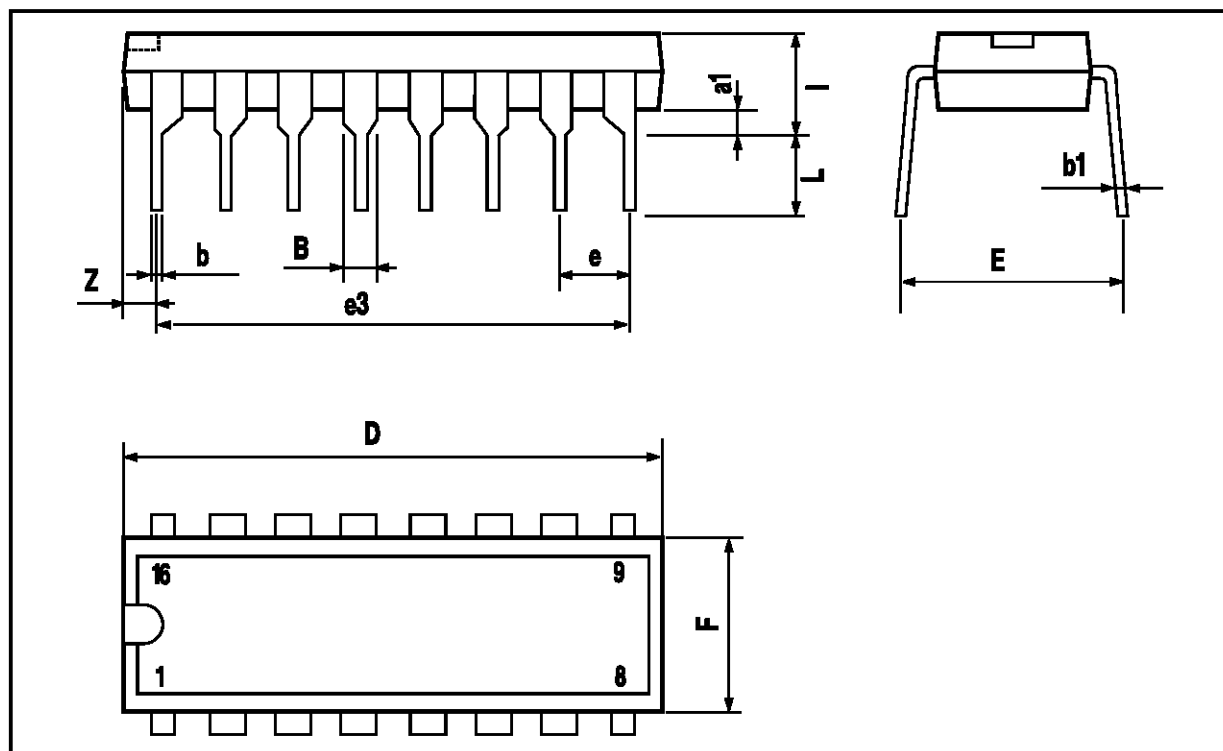

Information furnished is believed to be accurate and reliable. However, SGS-THOMSON Microelectronics assumes no responsibility for the consequences of use of such information nor for any infringement of patents or other rights of third parties which may result from its use. No license is granted by implication or otherwise under any patent or patent rights of SGS-THOMSON Microelectronics. Specification mentioned in this publication are subject to change without notice. This publication supersedes and replaces all information previously supplied. SGS-THOMSON Microelectronics products are not authorized for use as critical components in life support devices or systems without express written approval of SGS-THOMSON Microelectronics.

© 1996 SGS-THOMSON Microelectronics – Printed in Italy – All Rights Reserved
SGS-THOMSON Microelectronics GROUP OF COMPANIES
Australia - Brazil - Canada - China - France - Germany - Hong Kong - Italy - Japan - Korea - Malaysia - Malta - Morocco -
The Netherlands -Singapore - Spain - Sweden - Switzerland - Taiwan - Thailand - United Kingdom - U.S.A.