

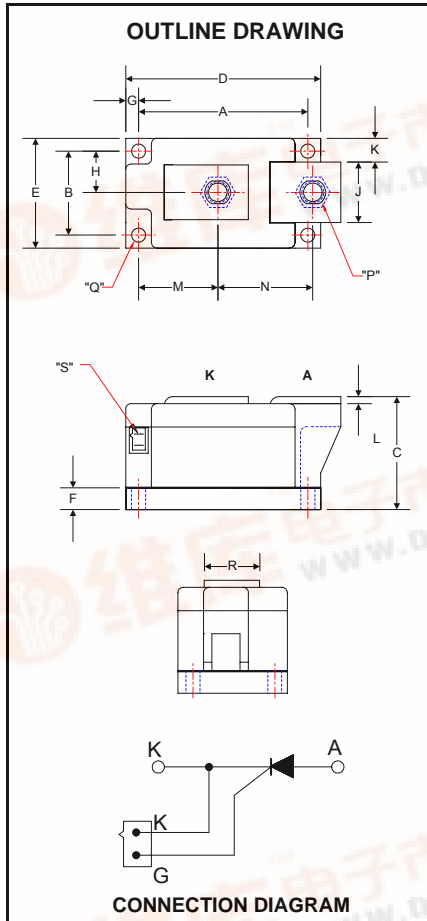

LS43_43

Powerex, Inc., Hillis Street, Youngwood, Pennsylvania 15697 (724) 925-7272

POW-R-BLOK™ Single SCR Isolated Module 430 Amperes / 1800-2200 Volts



**LS43_43
Single SCR
POW-R-BLOK™ Module
430 Amperes / 1800-2200 Volts**

LS43 Outline Dimensions

Dimension	Inches	Millimeters
A	3.15	80.0
B	1.50	38.0
C	2.05	52.1
D	3.62	92.0
E	1.97	50.0
F	0.39	9.9
G	0.24	6.1
H	0.79	20.1
J	0.99	25.1
K	0.48	12.2
L	0.12	3.1
M	1.45	36.8
N	1.76	44.7
P	M10 Metric	M10
Q	0.22 Dia.	5.6 Dia.
R	0.99	25.1
S	0.110 x .032	2.5 x 0.8

Note: Dimensions are for reference only.

Description:

Powerex Single SCR Modules are designed for use in applications requiring rectification and isolated packaging. The modules are isolated for easy mounting with other components on a common heatsink. POW-R-BLOK™ has been tested and recognized by the Underwriters Laboratories.

Features:

- Electrically Isolated Heatsinking
- Aluminum Nitride Insulator
- Compression Bonded Elements
- Metal Baseplate
- Low Thermal Impedance for Improved Current Capability
- Quick Connect Gate Terminal with Provision for Keyed Mating Plug
- UL Recognized

Benefits:

- No Additional Insulation Components Required
- Easy Installation
- No Clamping Components Required
- Reduce Engineering Time

Applications:

- Bridge Circuits
- AC & DC Motor Drives
- Battery Supplies
- Power Supplies
- Large IGBT Circuit Front Ends

Ordering Information:

Select the complete eight-digit module part number from the table below.

Example: LS432243 is a 2200 Volt, 430 Ampere Single SCR Isolated POW-R-BLOK™ Module

Type	Voltage Volts (x100)	Current Amperes (x10)
LS43	18	43
	20	
	22	



Absolute Maximum Ratings

Characteristics	Conditions	Symbol		Units
Repetitive Peak Forward and Reverse Blocking Voltage		V_{DRM} & V_{RRM}	up to 2200	V
Non-Repetitive Peak Blocking Voltage ($t < 5$ msec)		V_{RSM}	$V_{RRM} + 100$	V
RMS Forward Current		$I_{T(RMS)}$	800	A
Average Forward Current	180° Conduction, $T_C=80^\circ\text{C}$	$I_{T(AV)}$	430	A
	180° Conduction, $T_C=70^\circ\text{C}$	$I_{T(AV)}$	510	A
Peak One Cycle Surge Current, Non-Repetitive	60 Hz, 100% V_{RRM} reapplied, $T_j=25^\circ\text{C}$	I_{TSM}	14,000	A
	60 Hz, No V_{RRM} reapplied, $T_j=25^\circ\text{C}$	I_{TSM}	16,000	A
	60 Hz, 100% V_{RRM} reapplied, $T_j=125^\circ\text{C}$	I_{TSM}	12,000	A
	60 Hz, No V_{RRM} reapplied, $T_j=125^\circ\text{C}$	I_{TSM}	14,000	A
	50 Hz, 100% V_{RRM} reapplied, $T_j=25^\circ\text{C}$	I_{TSM}	12,000	A
	50 Hz, No V_{RRM} reapplied, $T_j=25^\circ\text{C}$	I_{TSM}	14,000	A
	50 Hz, 100% V_{RRM} reapplied, $T_j=125^\circ\text{C}$	I_{TSM}	10,000	A
	50 Hz, No V_{RRM} reapplied, $T_j=125^\circ\text{C}$	I_{TSM}	12,000	A
Peak Three Cycle Surge Current, Non-Repetitive	60 Hz, 100% V_{RRM} reapplied	I_{TSM}	8,600	A
Peak Ten Cycle Surge Current, Non-Repetitive	60 Hz, 100% V_{RRM} reapplied	I_{TSM}	7,500	A
I^2t for Fusing for One Cycle	8.3 milliseconds, $T_j=25^\circ\text{C}$	I^2t	1.07×10^6	$\text{A}^2 \text{sec}$
	8.3 milliseconds, $T_j=125^\circ\text{C}$	I^2t	0.82×10^6	$\text{A}^2 \text{sec}$
	10 milliseconds, $T_j=25^\circ\text{C}$	I^2t	0.98×10^6	$\text{A}^2 \text{sec}$
	10 milliseconds, $T_j=125^\circ\text{C}$	I^2t	0.72×10^6	$\text{A}^2 \text{sec}$
Maximum Rate-of-Rise of On-State Current, (Repetitive)	Per JEDEC Standard 397 5.2.2.6	di/dt	200	$\text{A}/\mu\text{s}$
Operating Temperature		T_J	-40 to +130	$^\circ\text{C}$
Storage Temperature		T_{stg}	-40 to +150	$^\circ\text{C}$
Max. Mounting Torque, M6 Mounting Screw			55	in. – Lb.
			6	Nm
Max. Mounting Torque, M10 Terminal Screw			110	in. – Lb.
			12	Nm
Module Weight, Typical			816	g
			1.80	lb
V Isolation @ 25C		V_{rms}	3000	V

Electrical Characteristics, T_J=25°C unless otherwise specified

Characteristics	Symbol	Test Conditions	Min.	Max.	Units
Repetitive Peak Forward Leakage Current	I _{DRM}	Up to 2200V, T _J =125°C		80	mA
Repetitive Peak Reverse Leakage Current	I _{RDM}	Up to 2200V, T _J =125°C		80	mA
Peak On-State Voltage	V _{FM}	I _{TM} =1500A		1.77	V
Threshold Voltage, Low-level	V _{(TO)1}	T _J = 130°C, I = 15%I _{T(AV)} to πI _{T(AV)}		0.88	V
Slope Resistance, Low-level	r _{T1}			0.66	mΩ
Threshold Voltage, High-level	V _{(TO)2}	T _J = 130°C, I = πI _{T(AV)} to I _{TSM}		1.34	V
Slope Resistance, High-level	r _{T2}			0.32	mΩ
V _{TM} Coefficients, Full Range		T _J = 130°C, I = 10A to 6kA V _{TM} = A + B Ln I + C I + D Sqrt I	A = B = C = D =	0.766 -1.046 E-02 1.805 E-05 2.00 E-02	
Minimum dV/dt	dV/dt	Exponential to V _{DRM} T _J =130°C, Gate Open	1000 Typ.		V/μs
Gate Trigger Current	I _{GT}	T _J =25°C, V _D =12V		200	mA
Gate Trigger Voltage	V _{GT}	T _J =25°C, V _D =12V		3.0	Volts
Non-Triggering Gate Voltage	V _{GDM}	T _J =130°C, V _D = ½ V _{DRM}		0.25	Volts
Peak Forward Gate Current	I _{GTM}			4.0	Amp
Peak Reverse Gate Voltage	V _{GDM}			5	Volts

Thermal Characteristics

Characteristics	Symbol		Max.	Units
Thermal Resistance, Junction to Case	R _{ΘJ-C}	Per Module/Junction	0.0650	°C/W
Thermal Impedance Coefficients	Z _{ΘJ-C}	Z _{ΘJ-C} = K ₁ (1-exp(-t/τ ₁)) + K ₂ (1-exp(-t/τ ₂)) + K ₃ (1-exp(-t/τ ₃)) + K ₄ (1-exp(-t/τ ₄))	K ₁ = 8.03E-04 K ₂ = 1.03E-02 K ₃ = 1.64E-02 K ₄ = 3.75E-02	τ ₁ = 3.39E-04 τ ₂ = 3.15E-03 τ ₃ = 0.106 τ ₄ = 2.066
Thermal Resistance, Case to Sink Lubricated	R _{ΘC-S}	Per Module	0.02	°C/W

Maximum On-State Forward Voltage Drop
 (T_J = 125 °C)

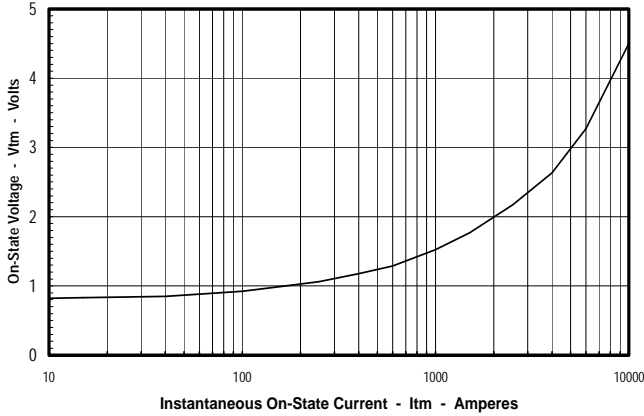

Maximum Transient Thermal Impedance
 (Junction to Case)

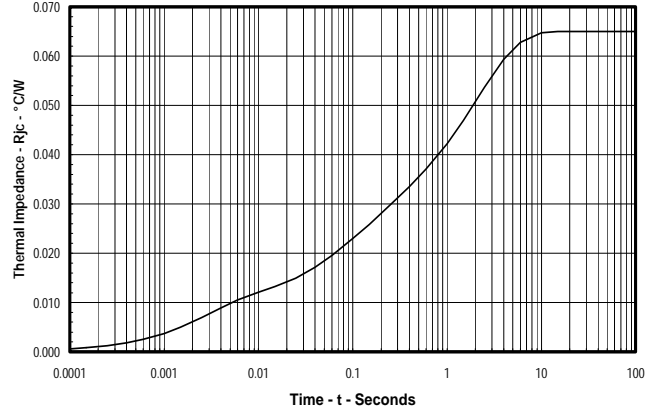

Maximum On-State Power Dissipation
 (Sinusoidal Waveform)

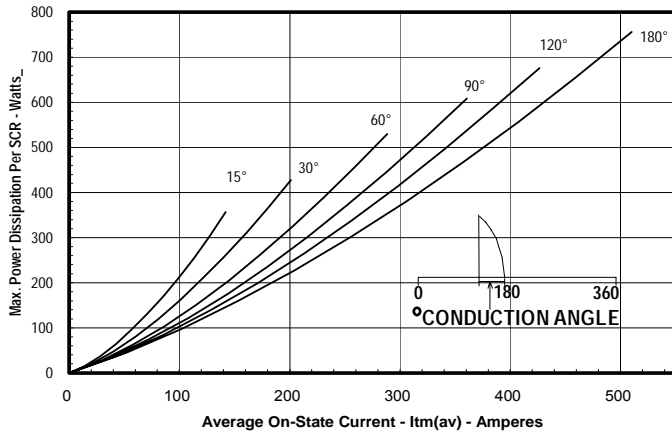

Maximum Allowable Case Temperature
 (Sinusoidal Waveform)

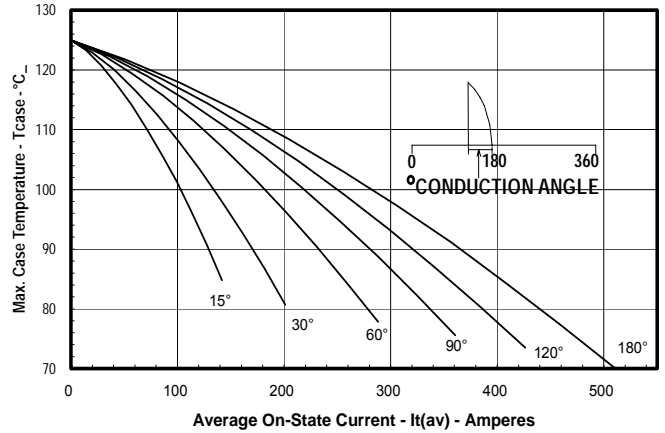

Maximum On-State Power Dissipation
 (Rectangular Waveform)

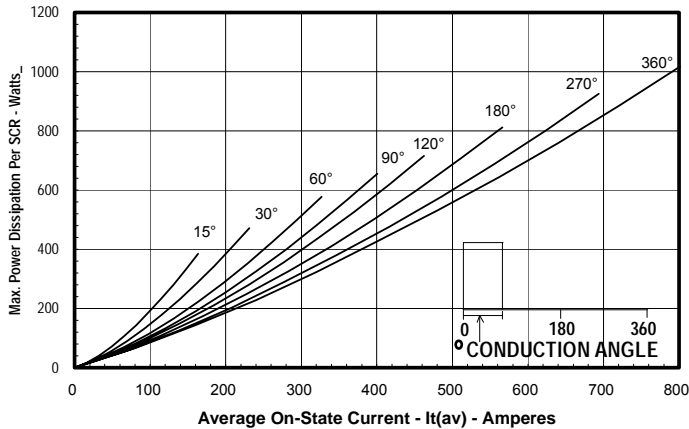

Maximum Allowable Case Temperature
 (Rectangular Waveform)

