

# LSI/CSI

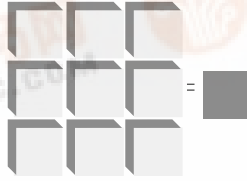

# LS7237



LSI Computer Systems, Inc. 1235 Walt Whitman Road, Melville, NY 11747 (631) 271-0400 FAX (631) 271-0405

## TOUCH CONTROL LAMP STEP DIMMER

April 1995

### FEATURES:

- PLL synchronization allows use as a Wall Switch
- Provides brightness control of an incandescent lamp with a touch plate or mechanical switch
- Can control speed of shaded pole and universal AC motors
- Controls the "duty cycle" from 23% to 88% (conduction angles for AC half-cycles between 45° and 158°, respectively)
- Operates at 50Hz/60Hz line frequency
- Extension input for remote activation
- +12V to +18V DC Power Supply (V<sub>SS</sub> - V<sub>DD</sub>)
- 8-Pin Plastic DIP, 8-Pin SOIC-See Figure 1

### DESCRIPTION:

LS7237 is a monolithic, MOS integrated circuit designed to control the brightness of an incandescent lamp. The output of the LS7237 triggers a triac connected in series with a lamp (See Figure 5). The lamp brightness is determined by controlling the output conduction angle (triac triggering angle) in relation to the AC line frequency (See Figure 2).

The output conduction angle can be varied by applying a low level pulse at the SENS input or a high level pulse at the EXT input. When implemented as shown in Figure 5, this is accomplished by touching the Touch Plate which causes the lamp brightness to change in specified steps as follows:

LEVEL	BRIGHTNESS (% Rated Wattage)
Off	0
Night Light	9
Mood Light	29
Medium	66
Maximum	99

The LS7237 can operate in one of three different modes selected by the MODE input. The Brightness Sequences produced by the different modes are as follows:

MODE	BRIGHTNESS SEQUENCE
0	Off-Max-Off
1	Off-Mood-Med-Max-Off
2	Off-Night-Mood-Med-Max-Off

After AC power-up, the output comes up in the OFF state. Following that, every time the Touch Plate is touched, the output steps to the next level of brightness. The next step following the maximum brightness is the OFF state, initiating a new sequence.

### PIN ASSIGNMENT - TOP VIEW

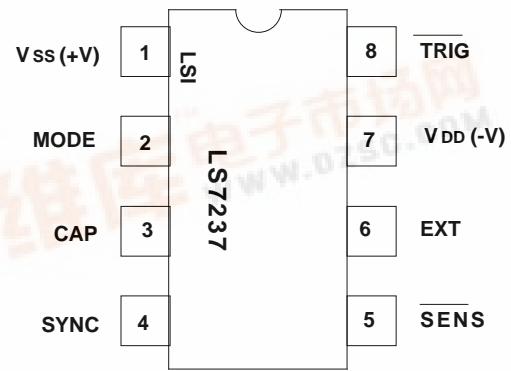

FIGURE 1

### INPUT/OUTPUT DESCRIPTION:

#### V<sub>SS</sub> (Pin 1)

Supply voltage positive terminal.

#### MODE (Pin 2)

The operating mode for the circuit is selected by connecting this input as follows:

MODE INPUT	SELECTED MODE
V <sub>SS</sub>	Mode 0
V <sub>DD</sub>	Mode 1
Float	Mode 2

#### CAP (Pin 3)

PLL filter input capacitor. A 0.047μF capacitor should be connected to this input.

#### SYNC (Pin 4)

The AC Line Frequency is applied to this input through an external RC circuit (See Figure 5). The Phase-Lock Loop in the IC synchronizes all internal timings to the AC signal at the SYNC input.

#### SENS (Pin 5)

A low-level pulse applied to this input causes the TRIG output to step to the next conduction angle in the sequence selected by the MODE input. The change in conduction angle takes place with the trailing edge of the SENS input pulse.

**EXT (Pin 6)**

The EXT input is functionally similar to the SENS input with the exception that a high-level pulse is the active signal. It is recommended that the EXT input be used instead of the SENS input when long extension wires are used between the IC and the sensing circuitry (See Figure 5 and Figure 6) because the EXT input is less susceptible to "Noise".

**VDD (Pin 7)**

Supply voltage negative terminal.

**TRIG (Pin 8)**

The TRIG output is a low-level pulse of fixed duration occurring once every half-cycle of the SYNC input. The conduction angle,  $\emptyset$  of the output in relation to the SYNC signal controls the lamp brightness. The 5 levels of brightness correspond to the 5 values of  $\emptyset$  as follows:

**CONDUCTION ANGLE,  $\emptyset$**

No output

45°

70°

105°

158°

**BRIGHTNESS LEVEL**

Off

Night Light

Mood Light

Medium

Maximum

**NOTE:** In the schematic shown in Figure 5, the SYNC Input signal is delayed in phase with respect to the AC Line by about 7°. This delay reduces the conduction angle,  $\emptyset$  with respect to the AC Line by 7° from the values shown above.

The information included herein is believed to be accurate and reliable. However, LSI Computer Systems, Inc. assumes no responsibilities for inaccuracies, nor for any infringements of patent rights of others which may result from its use.

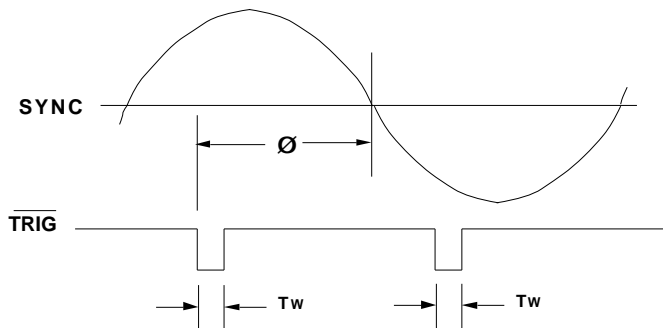

FIGURE 2. TRIG OUTPUT CONDUCTION ANGLE,  $\emptyset$

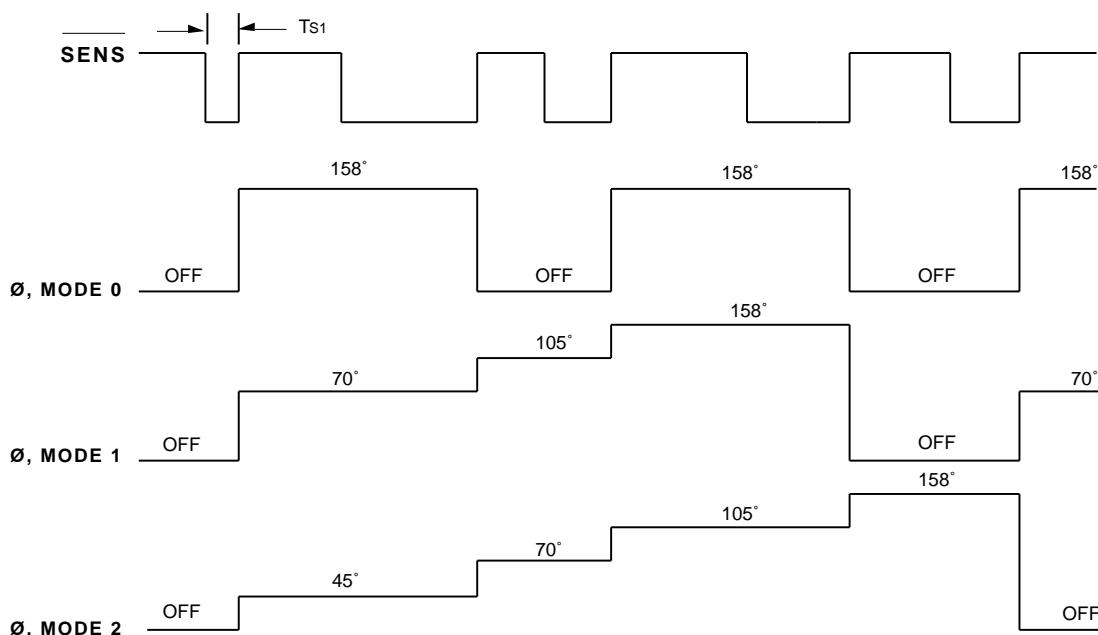

FIGURE 3. TRIG OUTPUT CONDUCTION ANGLE,  $\emptyset$ , VS SENS INPUT

**ABSOLUTE MAXIMUM RATINGS:**

PARAMETER	SYMBOL	VALUE	UNIT
DC Supply Voltage	V <sub>SS</sub>	+20	V
Any Input Voltage	V <sub>IN</sub>	V <sub>SS</sub> -20 to V <sub>SS</sub> +0.5	V
Operating Temperature	T <sub>A</sub>	0 to +80	°C
Storage Temperature	T <sub>STG</sub>	-65 to +150	°C

**DC ELECTRICAL CHARACTERISTICS:**  
(T<sub>A</sub> = 25°C, all voltages referenced to V<sub>DD</sub>)

PARAMETER	SYMBOL	MIN	TYPE	MAX	UNIT	CONDITION
Supply Voltage	V <sub>SS</sub>	+12	-	+18	V	-
Supply Current	I <sub>SS</sub>	-	1.0	1.4	mA	V <sub>SS</sub> = +15V, output off

**Input Voltages:**

PARAMETER	SYMBOL	MIN	TYPE	MAX	UNIT	CONDITION
MODE LO	V <sub>IzL</sub>	0	-	V <sub>SS</sub> -9	V	-
MODE HI	V <sub>IzH</sub>	V <sub>SS</sub> -1.5	-	V <sub>SS</sub>	V	-
SYNC LO	V <sub>IRL</sub>	0	-	V <sub>SS</sub> -9.5	V	-
SYNC HI	V <sub>IRH</sub>	V <sub>SS</sub> -5.5	-	V <sub>SS</sub>	V	-
SENS LO	V <sub>IOl</sub>	0	-	V <sub>SS</sub> -8	V	-
SENS HI	V <sub>IOH</sub>	V <sub>SS</sub> -2	-	V <sub>SS</sub>	V	-
EXT LO	V <sub>IVL</sub>	0	-	V <sub>SS</sub> -8	V	-
EXT HI	V <sub>IVH</sub>	V <sub>SS</sub> -2	-	V <sub>SS</sub>	V	-

**Input Current:**

SYNC, SENS, EXT HI	I <sub>IH</sub>	-	-	110	µA	With Series 1.5M Resistor to 115VAC Line
SYNC, SENS, EXT LO	I <sub>L</sub>	-	-	100	nA	-
TRIG HI Voltage	V <sub>OH</sub>	-	V <sub>SS</sub>	-	V	-
TRIG LO Voltage	V <sub>OL</sub>	-	V <sub>SS</sub> -8	-	V	V <sub>SS</sub> = +15V
TRIG Sink Current	I <sub>OS</sub>	25	-	-	mA	V <sub>SS</sub> = +15V V <sub>OL</sub> = V <sub>SS</sub> -4V

**TIMING CHARACTERISTICS** (See Figures 2 and 3):

All timings are based on f<sub>s</sub> = 60Hz, unless otherwise specified. 50Hz timings are 1.2 times 60Hz timings.

PARAMETER	SYMBOL	MIN	TYPE	MAX	UNIT
SYNC Frequency	f <sub>s</sub>	40	-	70	Hz
SENS/EXT Duration	T <sub>S1</sub>	50	-	Infinite	ms
TRIG Pulse Width	T <sub>w</sub>	-	33	-	µs

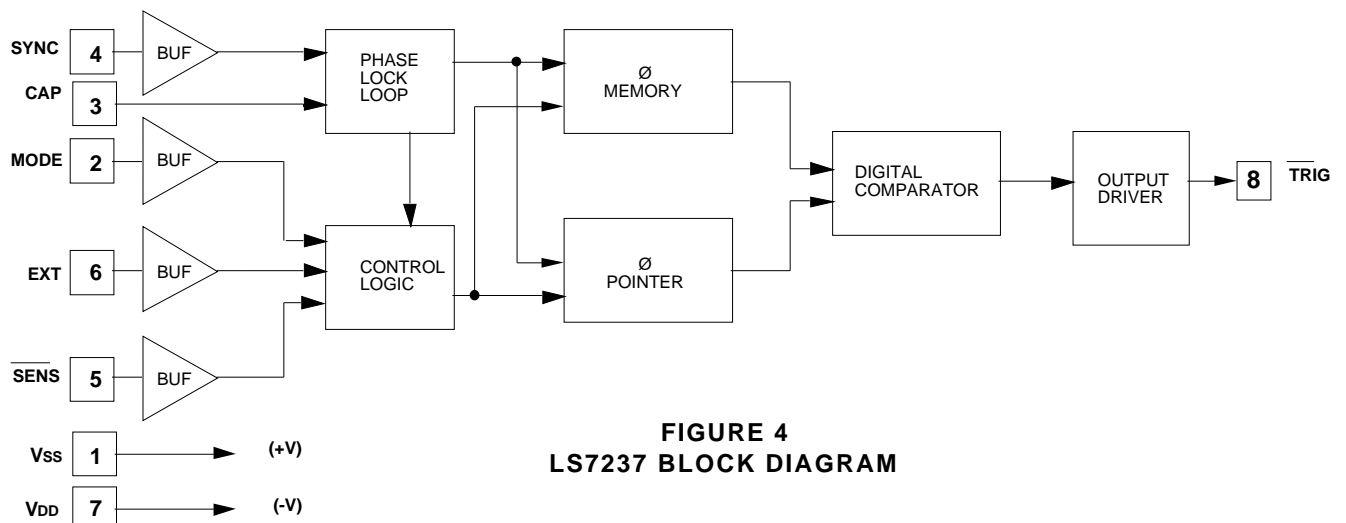

### APPLICATION EXAMPLES:

A typical implementation of a lamp dimmer circuit is shown in Fig. 5. Here the brightness of the lamp is set by touching the Touch Plate. The functions of different components are as follows:

- The 15V DC supply for the chip is provided by Z, D1, R1, C2, C5.
- R2 and C4 generate the filtered signal for the SYNC input for synchronizing the internal PLL with the line frequency.
- R3 and C7 act as filter circuit for the electronic extension. If extensions are not used, the EXT input (Pin 6) should be tied to VDD (Pin 7).
- R4, R5, R6 set up the sensitivity of the  $\overline{\text{SENS}}$  input. C6 provides noise filtering.
- C3 is the filter capacitor for the internal PLL.
- R8 provides current limiting and isolation between the chip output and the triac gate.
- C1 and L are RF filter circuits.

In the case of momentary power failure, the circuit state remains unchanged for a period up to 1 sec. For longer power interruptions, the output is shut off.

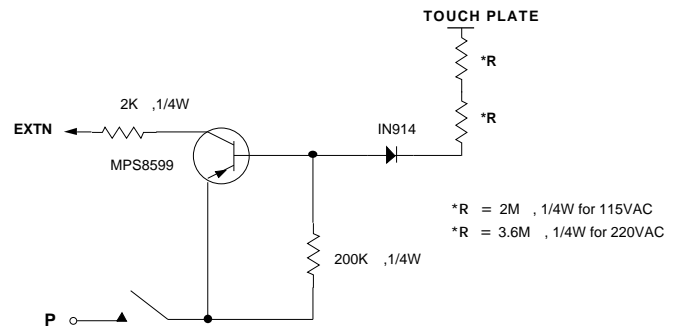
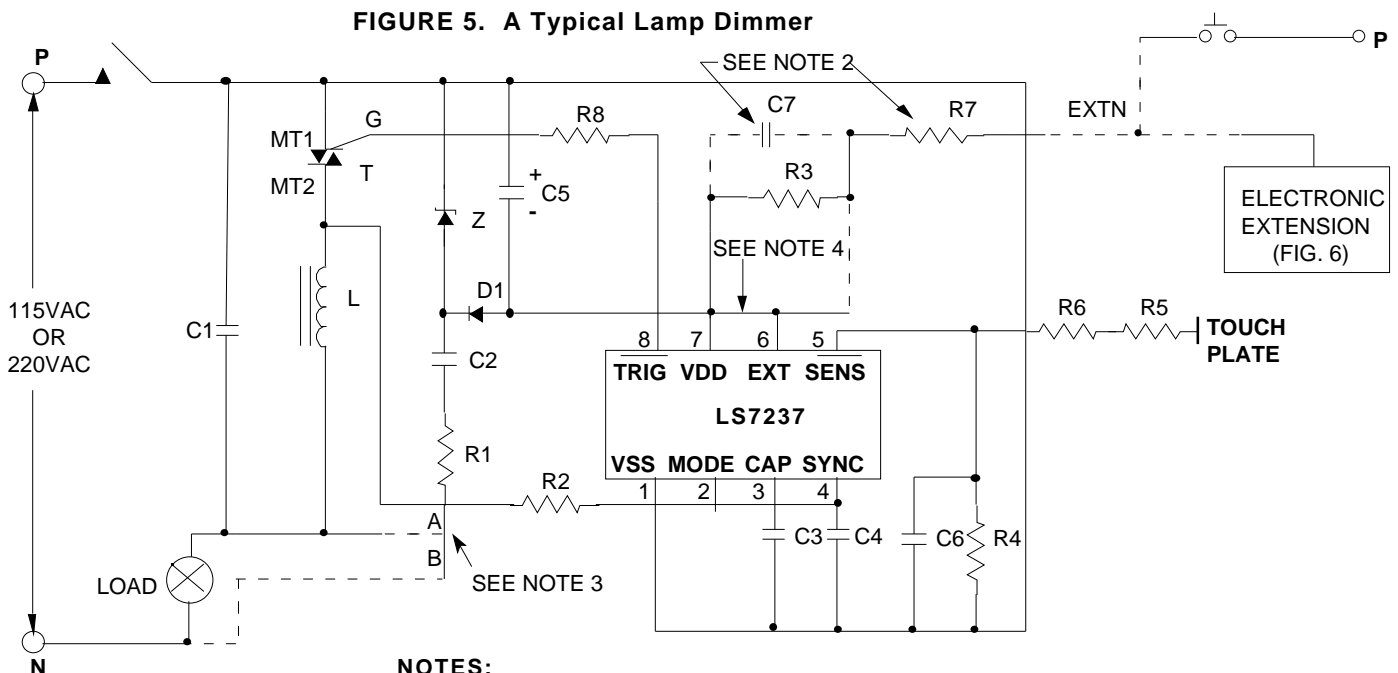

FIGURE 6. ELECTRONIC EXTENSION

### EXTENSIONS:

All switching and dimming functions can also be implemented by utilizing the EXT input. This can be done by either a mechanical switch or the electronic switch in conjunction with a Touch Plate as shown in Figure 6. When the plate is touched, a logic high level is generated at the EXT input of the IC for both half-cycles of the line frequency. (See Figure 5)

FIGURE 5. A Typical Lamp Dimmer



### NOTES:

- 1) All circuits connected by broken lines are optional.
- 2) C7 is used only with electronic extension and R7 is used only with mechanical switch
- 3) Use Connection A when Neutral is not available. Use Connection B when Neutral is available.
- 4) Connection between Pin 6 and Pin 7 should be broken when EXT is used.

### 115V

- |                             |                              |
|-----------------------------|------------------------------|
| C1 = 0.15 $\mu$ F, 200V     | R4 = 1M to 5M, 1/4W          |
| (1) C2 = 0.33 $\mu$ F, 200V | (Select for sensitivity)     |
| C3 = 0.047 $\mu$ F, 25V     | R5, R6 = 2.7M, 1/4W          |
| C4 = 470pF, 25V             | R7 = 150K, 1/4W              |
| C5 = 47 $\mu$ F, 25V        | R8 = 100, 1/4W               |
| C6 = 680pF, 25V             | D1 = 1N4148                  |
| C7 = 0.1 $\mu$ F, 25V       | Z = 15V, 1W (Zener)          |
| (2) R1 = 270, 1W            | T = Q5004L4 Triac (Typical)  |
| R2 = 1.5M, 1/4W             | L = 100 $\mu$ H (RFI Filter) |
| R3 = 1.5M, 1/4W             |                              |

### 220V

- |                             |                              |
|-----------------------------|------------------------------|
| C1 = 0.15 $\mu$ F, 400V     | R4 = 1M to 5M, 1/4W          |
| (3) C2 = 0.22 $\mu$ F, 400V | (Select for sensitivity)     |
| C3 = 0.047 $\mu$ F, 25V     | R5, R6 = 4.7M, 1/4W          |
| C4 = 470pF, 25V             | R7 = 150K, 1/4W              |
| C5 = 47 $\mu$ F, 25V        | R8 = 100, 1/4W               |
| C6 = 680pF, 25V             | D1 = 1N4148                  |
| C7 = 0.1 $\mu$ F, 25V       | Z = 15V, 1W (Zener)          |
| (4) R1 = 1K, 2W             | T = Q5004L4 Triac (Typical)  |
| R2 = 1.5M, 1/4W             | L = 200 $\mu$ H (RFI Filter) |
| R3 = 1.5M, 1/4W             |                              |

(1) For Connection A. Use 0.22 $\mu$ F for Connection B.

(2) For Connection A, Modes 1 and 2. Use 1/4W for Mode 0 and Connection B, all Modes.

(3) For Connection A. Use 0.1 $\mu$ F for Connection B.

(4) For Connection A, Modes 1 and 2. Use 1/4W for Mode 0 and Connection B, all Modes.