

LSI/CSI

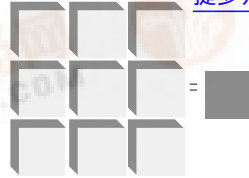

LS7339-7340



LSI Computer Systems, Inc. 1235 Walt Whitman Road, Melville, NY 11747 (631) 271-0400 FAX (631) 271-0405

AUTO SHUT-OFF AC POWER SWITCH WITH PROGRAMMABLE TIMER

June 2001

FEATURES:

- Phase-Lock Loop Synchronization allows use in Wall Switch Applications.
- PLL accuracy delivers Pure AC Power.
- Timer programmable with external R-C.
- $\overline{\text{ON}}$ input switches AC Power On and starts Timer.
- $\overline{\text{OFF}}$ input switches AC Power Off.
- 50/60Hz Line Frequency.
- +12V to +18V Operation ($V_{SS} - V_{DD}$).
- LS7339, LS7340 (DIP) - See Figure 1
- LS7339-S, LS7340-S (SOIC)

APPLICATIONS:

- AUTO SHUT-OFF TIMER for appliances such as coffee pots, curling irons, hair curlers, electric blankets, hand dryers.
- TIMED-ON WALL SWITCH for incandescent lighting and heat lamps.

DESCRIPTION:

The LS7339 and LS7340 are monolithic MOS integrated circuits designed to turn a triac On and Off in a Power Switch for AC loads. Activation of the $\overline{\text{ON}}$ input will always turn the triac On and start a Timer. The triac remains On for the duration of the Timer which is controlled by an external R-C connected to the OSCILLATOR input. Activation of the $\overline{\text{OFF}}$ input will always turn the triac Off. The two ICs differ only in the width of the TRIG pulse used to trigger the triac. (See I/O Description, Pin 4.)

In a typical application (Figure 5), the output of the LS7339 drives the gate of a triac in series with the load. Because the LS7339 is accurately synchronized to the line frequency with a phase-lock loop, the power delivered by the triac to the load is pure AC, allowing use with inductive loads such as motors and transformers.

There are two states through which the LS7339 can be stepped. The states and their corresponding operating modes, phase angles, and delivered power levels are shown in Table 1.

TABLE 1

(See Figures 2 and 3)	STATE 0	STATE 1
OPERATING MODE	OFF	Timed-On
PHASE ANGLE, ϕ	No Output	159°
% LOAD POWER (1)	0	99

(1) The percentage of full power delivered to a resistive load by the triac switch.

OPERATING DESCRIPTION:

Upon power up, internal power-on-reset starts the LS7339 in STATE 0. When the $\overline{\text{ON}}$ input transitions to logic 0, the circuit steps to STATE 1. When the $\overline{\text{OFF}}$ input transitions to logic 0, the circuit steps to STATE 0. When implemented as shown in the application example (Figure 5), this is accomplished by the momentary switching of the appropriate input to V_{DD} through S1. STATE 1 is a quasi-stable state.

PIN ASSIGNMENT - TOP VIEW

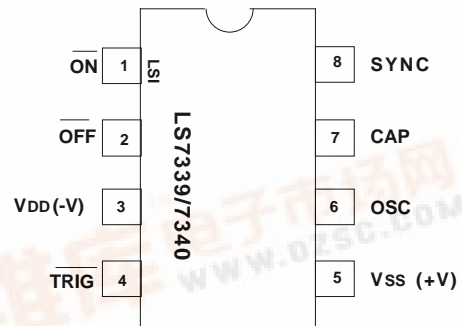

FIGURE 1

If left in STATE 1, after a time-out period determined by the frequency set at the OSC input (See I/O Description, Pin 6), the circuit automatically steps to STATE 0. If the $\overline{\text{ON}}$ input transitions to logic 0 before completion of the time-out period in STATE 1, the Timer is restarted, beginning a new time-out

INPUT/OUTPUT DESCRIPTION:

$\overline{\text{ON}}$ (Pin 1) - See NOTE 1

A logic 0 applied to this input for a minimum of three SYNC cycles, T_{S1} (50ms for 60Hz, 60ms for 50Hz), turns $\overline{\text{TRIG}}$ On and starts a Timer. Upon completion of the Time-out, T_{D1} , $\overline{\text{TRIG}}$ turns Off. While the Time-out is in progress a new transition to logic 0 at this input for a minimum of three SYNC Cycles, T_{S1} , restarts the Timer. This input is designed for Touch or Switch control. (See Figure 5.)

$\overline{\text{OFF}}$ (Pin 2) - See NOTE 2

A logic 0 applied to this input for a minimum of three SYNC cycles, T_{S1} , turns $\overline{\text{TRIG}}$ Off. This input is designed for Switch control only. (See Figure 5.)

V_{DD} (Pin 3)

Supply voltage negative terminal.

$\overline{\text{TRIG}}$ (Pin 4)

$\overline{\text{TRIG}}$ is a negative going pulse occurring once every half cycle of the SYNC input. Pulse width is 1ms (LS7339) or 33 μ s (LS7340). The LS7339 wide pulse width may be required for inductive loads. The LS7340 narrow pulse width allows use of a smaller value of C2 power supply capacitor. (See Figure 5.)

V_{SS} (Pin 5)

Supply voltage positive terminal.

OSC (Pin 6)

An R-C network connected to this input controls the frequency of oscillation which determines the Time-out, T_{D1} , in State 1. T_{D1} is approximately 255RC. The Oscillator is active only in State 1. Chip to chip Oscillation Tolerance is $\pm 10\%$ for fixed value of RC. Tie Pin 6 to V_{SS} if a Time-out is not desired. (See Figure 5.)

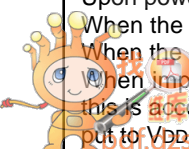

CAP (Pin 7)

The CAP input is for external component connection for the PLL filter capacitor. (See Figure 5.)

SYNC (Pin 8).

The AC Line Frequency (50/60Hz) is applied to this input. The Phase-Lock Loop synchronizes all internal timings to the AC signal at the SYNC input. (See Figure 5.)

NOTE 1: \overline{ON} will function as described if \overline{OFF} is at logic 1. If \overline{OFF} is held at logic 0, the transitions at \overline{ON} will not cause the output to turn On.

NOTE 2: \overline{OFF} will function as described if \overline{ON} is at logic 1. If \overline{ON} is held at logic 0, the transitions at \overline{OFF} will not cause the the output to turn Off.

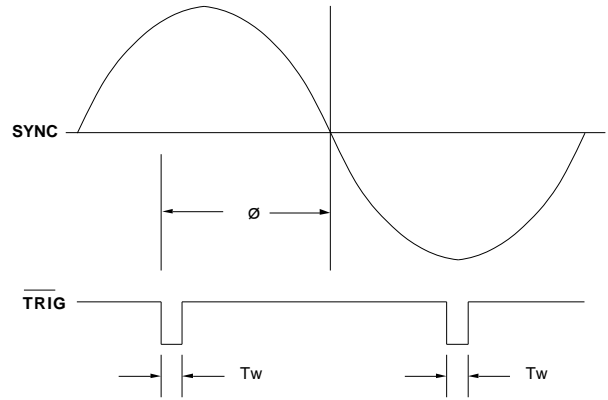

FIGURE 2. OUTPUT CONDUCTION ANGLE, Ø

FIGURE 3. PHASE ANGLE, Ø, vs \overline{ON} AND \overline{OFF}

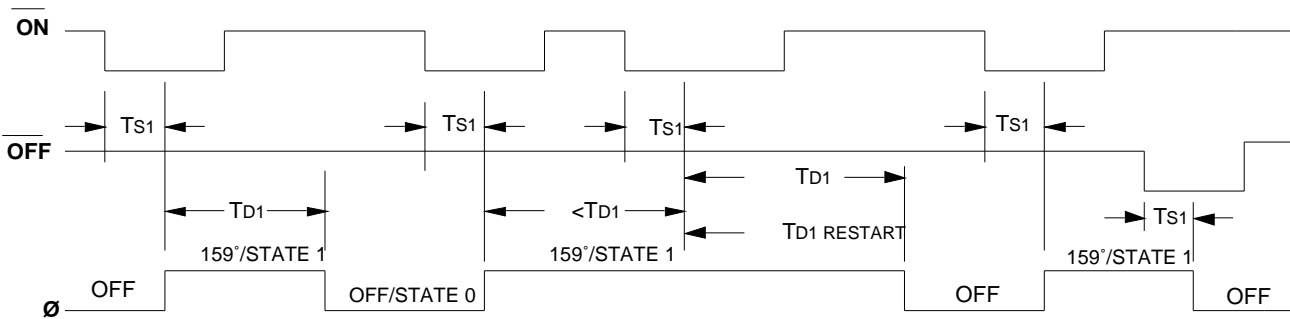
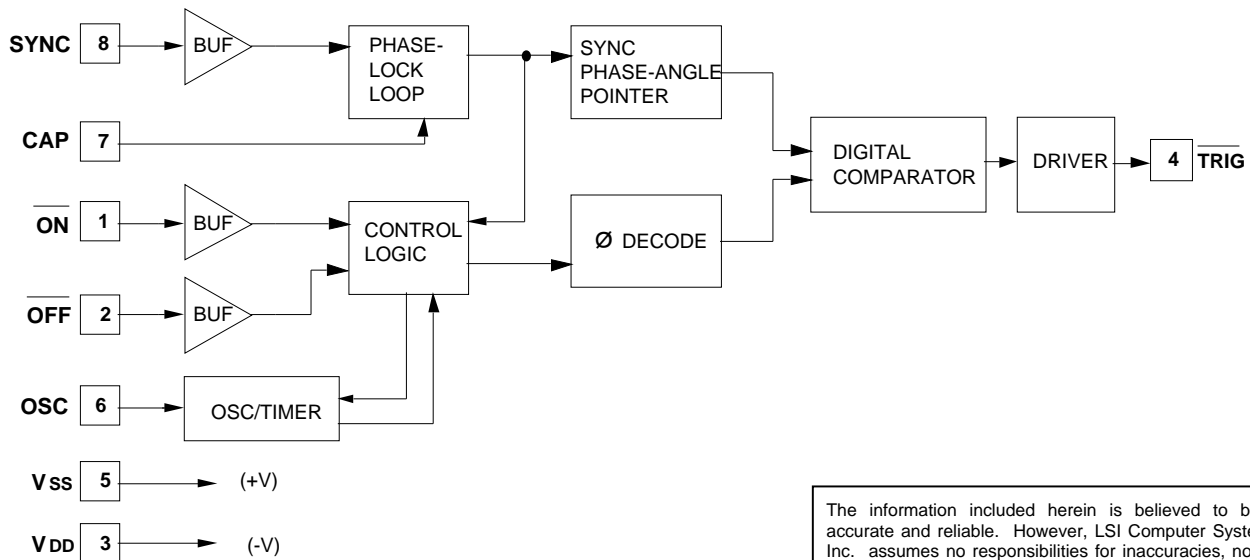

FIGURE 4. LS7339/7340 BLOCK DIAGRAM



The information included herein is believed to be accurate and reliable. However, LSI Computer Systems, Inc. assumes no responsibilities for inaccuracies, nor for any infringements of patent rights of others which may result from its use.

ABSOLUTE MAXIMUM RATINGS:

PARAMETER	SYMBOL	VALUE	UNIT
DC supply voltage	V _{SS} - V _{DD}	+20	V
Any input voltage	V _{IN}	V _{SS} -20 to V _{SS} + .5	V
Operating temperature	T _A	0 to +85	°C
Storage temperature	T _{STG}	-65 to +150	°C

DC ELECTRICAL CHARACTERISTICS:(T_A = 25°C, all voltages referenced to V_{DD})

PARAMETER	SYMBOL	MIN	TYP	MAX	UNIT	CONDITIONS
Supply Voltage	V _{SS}	+12	-	+18	V	-
Supply Current	I _{SS}	-	1.6	2.2	mA	V _{SS} = +15V, Output off
Input Voltages						
SYNC Lo	V _{IRL}	0	-	V _{SS} -9.5	V	-
SYNC Hi	V _{IRH}	V _{SS} -5.5	-	V _{SS}	V	-
ON Lo	V _{IO_L}	0	-	V _{SS} -8	V	-
ON Hi	V _{IO_H}	V _{SS} -2	-	V _{SS}	V	-
OFF Lo	V _{IVL}	0	-	V _{SS} -8	V	-
OFF Hi	V _{IVH}	V _{SS} -2	-	V _{SS}	V	-
Input Current						
SYNC, ON & OFF Hi	I _{IH}	-	-	110	uA	With Series 1.5M Resistor to 115VAC
SYNC, ON & OFF Lo	I _{IL}	-	-	100	nA	-
TRIG Hi Voltage	V _{OH}	-	V _{SS}	-	V	-
TRIG Lo Voltage	V _{OL}	-	V _{SS} -8	-	V	V _{SS} = +15V
TRIG Sink Current	I _{OS}	25	-	-	mA	V _{SS} = +15V, V _{OL} = V _{SS} - 4V

TRANSIENT CHARACTERISTICS (See Fig. 2 and 3)(All timings are based on F_s = 60Hz, unless otherwise specified.)

PARAMETER	SYMBOL	MIN	TYP	MAX	UNIT
SYNC Frequency	F _s	40	-	70	Hz
ON/OFF Sense Time	T _{s1}	50	-	Infinite	ms
TRIG Pulse Width					
(LS7339)	T _w	-	1.0	-	ms
(LS7340)	T _w	-	33	-	µs
STATE 1 Time-out	T _{D1}	-	255RC	-	s

TABLE 2. COMPONENT FUNCTIONAL DESCRIPTION FOR FIGURE 5

COMPONENTS	FUNCTIONAL DESCRIPTION
Z1, D1, R1, C2, C3	DC Power Supply.
R2, C4	Current limit and filter AC for SYNC input.
C1, L1	RFI filtering for AC Mains.
C5	PLL filter capacitor.
R5	Current limiting and isolation between IC output and Triac Gate.
R6, R7, C6	Oscillator R-C network.
	Potentiometer R6 required only if providing user adjustment of Time-out, TD1.
R3, R4	Pullup resistors to establish normally inactive condition of ON and OFF inputs.
S1	Momentary Double Throw Switch used to activate appropriate input.

FIGURE 5. A TYPICAL AUTO SHUT-OFF AC POWER SWITCH

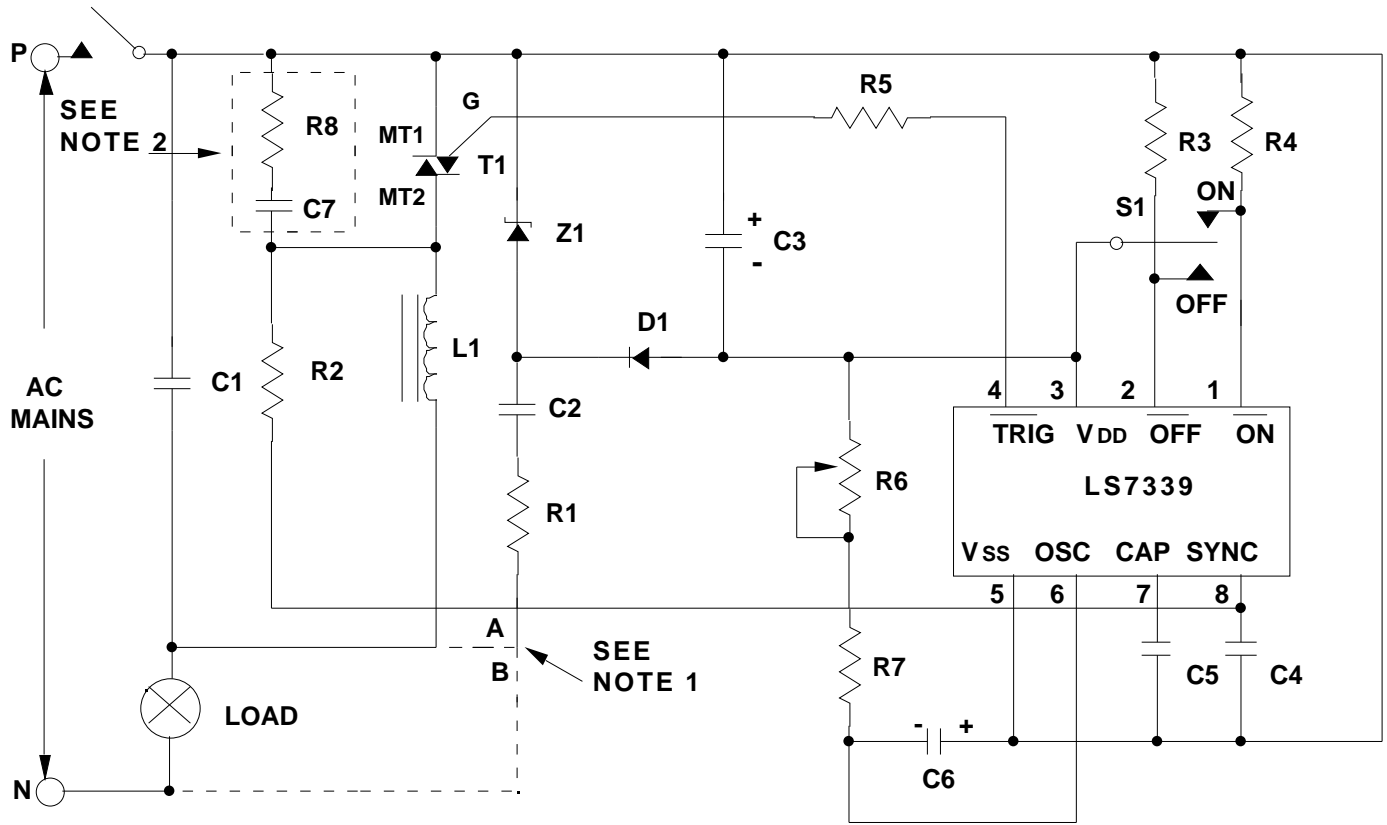

- NOTES:** 1. Use Connection A when Neutral is not available. Use Connection B when Neutral is available.
 2. Snubber Network C7, R8 may be required for some inductive loads.
 3. See Table 2 for Component Functional Description.

	115VAC	220VAC		115VAC	220VAC
(1)(3) R1	150 , 1W	360 , 2W	(1)(2)C3	100μF	100μF
(2)(4) R1	82	82	(3)(4)C3	47μF	47μF
R2	1.5M	1.5M	C4	470pF	470pF
R3	100k	100k	C5	0.047μF	0.047μF
R4	100k	100k	C6	(6)	(6)
R5	100	100	C7	0.1μF, 200V	0.1μF, 400V
R6	(5)(6)	(5)(6)	Z1	15V, 1/2W	15V, 1/2W
R7	(5)(6)	(5)(6)	D1	1N4148	1N4148
R8	1.8k , 1W	1.8k , 2W	L1	100μH	200μH
C1	0.15μF, 200V	0.15μF, 400V	(7)T1	Q4008L4	Q5004L4
(1) C2	1.0μF, 200V	0.47μF, 400V			
(2) C2	0.47μF, 200V	0.22μF, 400V			
(3) C2	0.33μF, 200V	0.22μF, 400V			
(4) C2	0.22μF, 200V	0.1μF, 400V			

- (1) LS7339, Connection A
 (2) LS7339, Connection B
 (3) LS7340, Connection A
 (4) LS7340, Connection B
 (5) 100k (R6 + R7) 10M
 (6) (R6 + R7)C6 5ms
 (7) Typical

All Resistors 1/4W, all Capacitors 25V unless otherwise specified

FIGURE 6. PRODUCING VERY LONG TIME-OUTS BY PULSE MODULATING THE OSCILLATOR

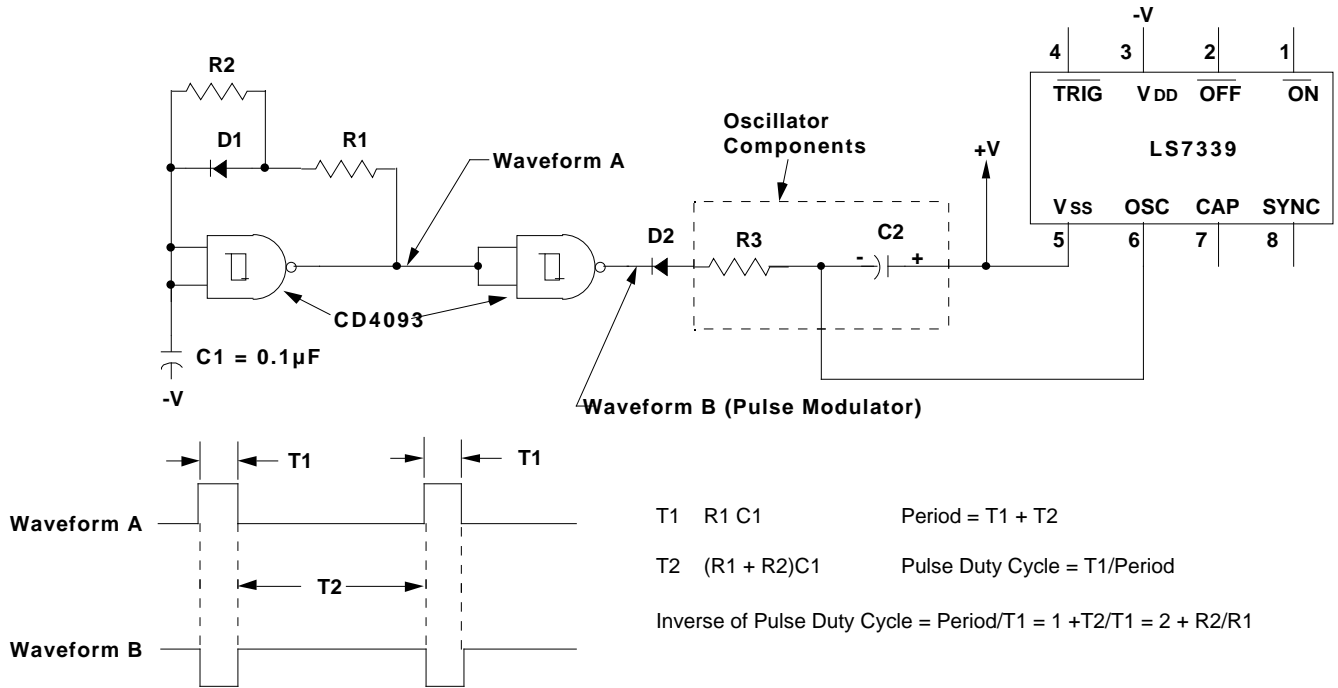

DESCRIPTION The Oscillator resistor is normally returned to the negative terminal of the DC Supply. If this resistor is returned to a negative-going pulse instead, the Oscillator R-C becomes effectively multiplied by the inverse of the Pulse Duty Cycle, because the Oscillator R-C can charge only while the pulse is present. (Pulse Modulation)
 In Figure 6, the Oscillator R is R₃, the Oscillator C is C₂ and the Pulse Modulator is Waveform B through isolation diode D₂. The Multiplier, $M = 2 + R_2/R_1$ (the inverse of the Pulse Duty Cycle).

EXAMPLE R₃ = 5.1M , C₂ = 1.0μF, Pulse Modulator = Waveform B and desired T_{D1} = 8 hours = 28,800 sec.
 Since T_{D1} = 255 x M x R₃ x C₂, M calculates to be 22 for the selected Oscillator Components.
 With M = 22, R₂/R₁ = 20. If R₂ = 3M , R₁ = 150k .