



DECADE COUNTER; DIVIDE-BY-TWELVE COUNTER; 4-BIT BINARY COUNTER

The SN54/74LS90, SN54/74LS92 and SN54/74LS93 are high-speed 4-bit ripple type counters partitioned into two sections. Each counter has a divide-by-two section and either a divide-by-five (LS90), divide-by-six (LS92) or divide-by-eight (LS93) section which are triggered by a HIGH-to-LOW transition on the clock inputs. Each section can be used separately or tied together (Q to \overline{CP}) to form BCD, bi-quinary, modulo-12, or modulo-16 counters. All of the counters have a 2-input gated Master Reset (Clear), and the LS90 also has a 2-input gated Master Set (Preset 9).

- Low Power Consumption . . . Typically 45 mW
- High Count Rates . . . Typically 42 MHz
- Choice of Counting Modes . . . BCD, Bi-Quinary, Divide-by-Twelve, Binary
- Input Clamp Diodes Limit High Speed Termination Effects

PIN NAMES

\overline{CP}_0	Clock (Active LOW going edge) Input to +2 Section
\overline{CP}_1	Clock (Active LOW going edge) Input to +5 Section (LS90), +6 Section (LS92)
\overline{CP}_1	Clock (Active LOW going edge) Input to +8 Section (LS93)
MR ₁ , MR ₂	Master Reset (Clear) Inputs
MS ₁ , MS ₂	Master Set (Preset-9, LS90) Inputs
Q ₀	Output from +2 Section (Notes b & c)
Q ₁ , Q ₂ , Q ₃	Outputs from +5 (LS90), +6 (LS92), +8 (LS93) Sections (Note b)

LOADING (Note a)

	HIGH	LOW
\overline{CP}_0	0.5 U.L.	1.5 U.L.
\overline{CP}_1	0.5 U.L.	2.0 U.L.
\overline{CP}_1	0.5 U.L.	1.0 U.L.
MR ₁ , MR ₂	0.5 U.L.	0.25 U.L.
MS ₁ , MS ₂	0.5 U.L.	0.25 U.L.
Q ₀	10 U.L.	5 (2.5) U.L.
Q ₁ , Q ₂ , Q ₃	10 U.L.	5 (2.5) U.L.

NOTES:

- 1 TTL Unit Load (U.L.) = 40 μ A HIGH/1.6 mA LOW.
- The Output LOW drive factor is 2.5 U.L. for Military, (54) and 5 U.L. for commercial (74) Temperature Ranges.
- The Q₀ Outputs are guaranteed to drive the full fan-out plus the CP₁ input of the device.
- To insure proper operation the rise (t_r) and fall time (t_f) of the clock must be less than 100 ns.

**SN54/74LS90
SN54/74LS92
SN54/74LS93**

**DECADE COUNTER;
DIVIDE-BY-TWELVE COUNTER;
4-BIT BINARY COUNTER
LOW POWER SCHOTTKY**

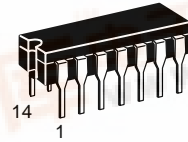

**J SUFFIX
CERAMIC
CASE 632-08**

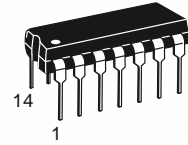

**N SUFFIX
PLASTIC
CASE 646-06**

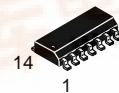

**D SUFFIX
SOIC
CASE 751A-02**

ORDERING INFORMATION

SN54LSXXJ	Ceramic
SN74LSXXN	Plastic
SN74LSXXD	SOIC

LOGIC SYMBOL

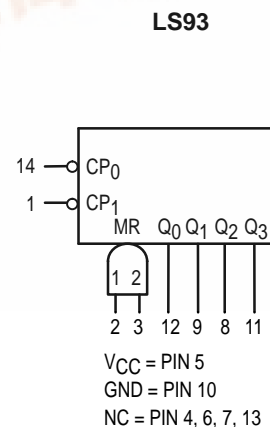
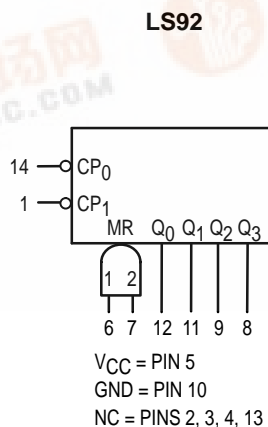
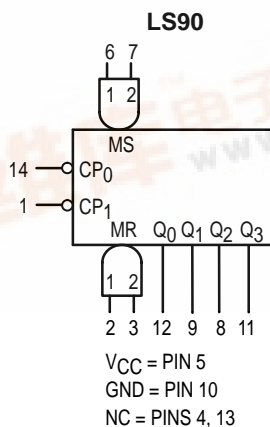

SN54/74LS90 • SN54/74LS92 • SN54/74LS93

LOGIC DIAGRAM

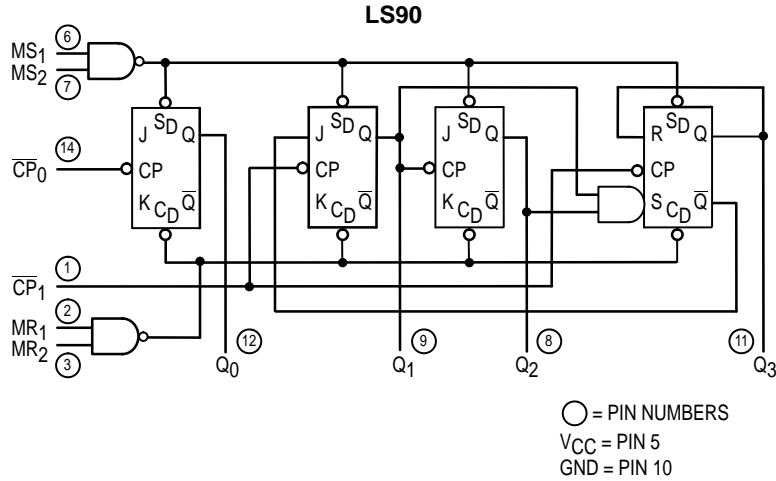

CONNECTION DIAGRAM DIP (TOP VIEW)

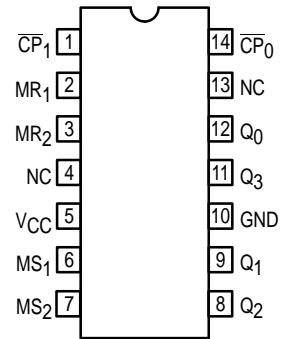

NC = NO INTERNAL CONNECTION

NOTE:
The Flatpak version has the same pinouts (Connection Diagram) as the Dual In-Line Package.

LOGIC DIAGRAM

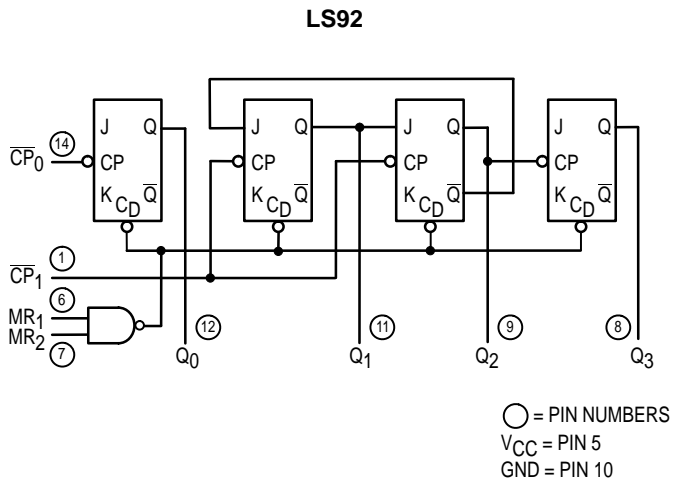

CONNECTION DIAGRAM DIP (TOP VIEW)

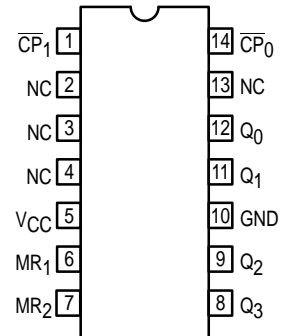

NC = NO INTERNAL CONNECTION

NOTE:
The Flatpak version has the same pinouts (Connection Diagram) as the Dual In-Line Package.

LOGIC DIAGRAM

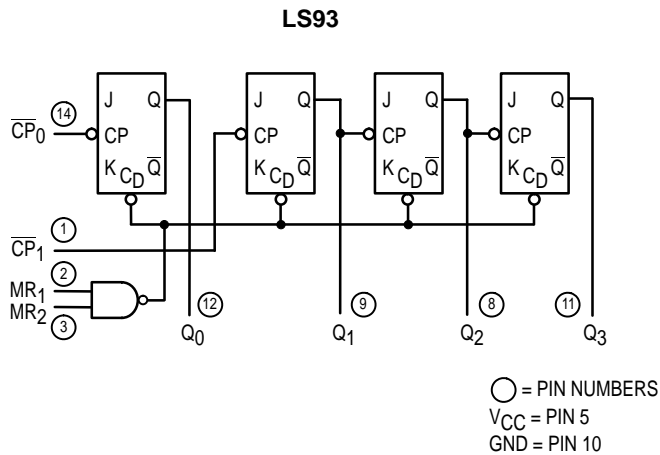

CONNECTION DIAGRAM DIP (TOP VIEW)

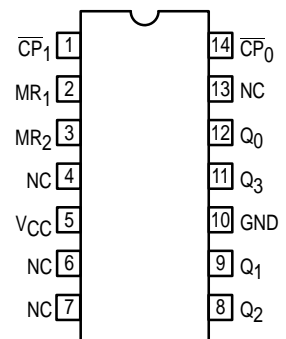

NC = NO INTERNAL CONNECTION

NOTE:
The Flatpak version has the same pinouts (Connection Diagram) as the Dual In-Line Package.

SN54/74LS90 • SN54/74LS92 • SN54/74LS93

FUNCTIONAL DESCRIPTION

The LS90, LS92, and LS93 are 4-bit ripple type Decade, Divide-By-Twelve, and Binary Counters respectively. Each device consists of four master/slave flip-flops which are internally connected to provide a divide-by-two section and a divide-by-five (LS90), divide-by-six (LS92), or divide-by-eight (LS93) section. Each section has a separate clock input which initiates state changes of the counter on the HIGH-to-LOW clock transition. State changes of the Q outputs do not occur simultaneously because of internal ripple delays. Therefore, decoded output signals are subject to decoding spikes and should not be used for clocks or strobes. The Q_0 output of each device is designed and specified to drive the rated fan-out plus the \overline{CP}_1 input of the device.

A gated AND asynchronous Master Reset ($MR_1 \bullet MR_2$) is provided on all counters which overrides and clocks and resets (clears) all the flip-flops. A gated AND asynchronous Master Set ($MS_1 \bullet MS_2$) is provided on the LS90 which overrides the clocks and the MR inputs and sets the outputs to nine (HLLH).

Since the output from the divide-by-two section is not internally connected to the succeeding stages, the devices may be operated in various counting modes.

LS90

- A. BCD Decade (8421) Counter — The \overline{CP}_1 input must be externally connected to the Q_0 output. The \overline{CP}_0 input receives the incoming count and a BCD count sequence is produced.
- B. Symmetrical Bi-quinary Divide-By-Ten Counter — The Q_3 output must be externally connected to the \overline{CP}_0 input. The input count is then applied to the \overline{CP}_1 input and a divide-by-ten square wave is obtained at output Q_0 .

- C. Divide-By-Two and Divide-By-Five Counter — No external interconnections are required. The first flip-flop is used as a binary element for the divide-by-two function (\overline{CP}_0 as the input and Q_0 as the output). The \overline{CP}_1 input is used to obtain binary divide-by-five operation at the Q_3 output.

LS92

- A. Modulo 12, Divide-By-Twelve Counter — The \overline{CP}_1 input must be externally connected to the Q_0 output. The \overline{CP}_0 input receives the incoming count and Q_3 produces a symmetrical divide-by-twelve square wave output.
- B. Divide-By-Two and Divide-By-Six Counter — No external interconnections are required. The first flip-flop is used as a binary element for the divide-by-two function. The \overline{CP}_1 input is used to obtain divide-by-three operation at the Q_1 and Q_2 outputs and divide-by-six operation at the Q_3 output.

LS93

- A. 4-Bit Ripple Counter — The output Q_0 must be externally connected to input \overline{CP}_1 . The input count pulses are applied to input \overline{CP}_0 . Simultaneous divisions of 2, 4, 8, and 16 are performed at the Q_0 , Q_1 , Q_2 , and Q_3 outputs as shown in the truth table.
- B. 3-Bit Ripple Counter — The input count pulses are applied to input \overline{CP}_1 . Simultaneous frequency divisions of 2, 4, and 8 are available at the Q_1 , Q_2 , and Q_3 outputs. Independent use of the first flip-flop is available if the reset function coincides with reset of the 3-bit ripple-through counter.

SN54/74LS90 • SN54/74LS92 • SN54/74LS93

**LS90
MODE SELECTION**

RESET/SET INPUTS				OUTPUTS			
MR ₁	MR ₂	MS ₁	MS ₂	Q ₀	Q ₁	Q ₂	Q ₃
H	H	L	X	L	L	L	L
H	H	X	L	L	L	L	L
X	X	H	H	H	L	L	H
L	X	L	X	Count			
X	L	X	L	Count			
L	X	X	L	Count			
X	L	L	X	Count			

H = HIGH Voltage Level
L = LOW Voltage Level
X = Don't Care

**LS92 AND LS93
MODE SELECTION**

RESET INPUTS		OUTPUTS			
MR ₁	MR ₂	Q ₀	Q ₁	Q ₂	Q ₃
H	H	L	L	L	L
L	H	Count			
H	L	Count			
L	L	Count			

H = HIGH Voltage Level
L = LOW Voltage Level
X = Don't Care

**LS90
BCD COUNT SEQUENCE**

COUNT	OUTPUT			
	Q ₀	Q ₁	Q ₂	Q ₃
0	L	L	L	L
1	H	L	L	L
2	L	H	L	L
3	H	H	L	L
4	L	L	H	L
5	H	L	H	L
6	L	H	H	L
7	H	H	H	L
8	L	L	L	H
9	H	L	L	H

NOTE: Output Q₀ is connected to Input CP₁ for BCD count.

**LS92
TRUTH TABLE**

COUNT	OUTPUT			
	Q ₀	Q ₁	Q ₂	Q ₃
0	L	L	L	L
1	H	L	L	L
2	L	H	L	L
3	H	H	L	L
4	L	L	H	L
5	H	L	H	L
6	L	L	L	H
7	H	L	L	H
8	L	H	L	H
9	H	H	L	H
10	L	L	H	H
11	H	L	H	H

NOTE: Output Q₀ is connected to Input CP₁.

**LS93
TRUTH TABLE**

COUNT	OUTPUT			
	Q ₀	Q ₁	Q ₂	Q ₃
0	L	L	L	L
1	H	L	L	L
2	L	H	L	L
3	H	H	L	L
4	L	L	H	L
5	H	L	H	L
6	L	H	H	L
7	H	H	H	L
8	L	L	L	H
9	H	L	L	H
10	L	H	L	H
11	H	H	L	H
12	L	L	H	H
13	H	L	H	H
14	L	H	H	H
15	H	H	H	H

NOTE: Output Q₀ is connected to Input CP₁.

SN54/74LS90 • SN54/74LS92 • SN54/74LS93

GUARANTEED OPERATING RANGES

Symbol	Parameter		Min	Typ	Max	Unit
V _{CC}	Supply Voltage	54 74	4.5 4.75	5.0 5.0	5.5 5.25	V
T _A	Operating Ambient Temperature Range	54 74	-55 0	25 25	125 70	°C
I _{OH}	Output Current — High	54, 74			-0.4	mA
I _{OL}	Output Current — Low	54 74			4.0 8.0	mA

DC CHARACTERISTICS OVER OPERATING TEMPERATURE RANGE (unless otherwise specified)

Symbol	Parameter	Limits			Unit	Test Conditions	
		Min	Typ	Max			
V _{IH}	Input HIGH Voltage	2.0			V	Guaranteed Input HIGH Voltage for All Inputs	
V _{IL}	Input LOW Voltage	54		0.7	V	Guaranteed Input LOW Voltage for All Inputs	
		74		0.8			
V _{IK}	Input Clamp Diode Voltage		-0.65	-1.5	V	V _{CC} = MIN, I _{IN} = -18 mA	
V _{OH}	Output HIGH Voltage	54	2.5	3.5	V	V _{CC} = MIN, I _{OH} = MAX, V _{IN} = V _{IH} or V _{IL} per Truth Table	
		74	2.7	3.5	V		
V _{OL}	Output LOW Voltage	54, 74		0.25	0.4	V	V _{CC} = V _{CC} MIN, V _{IN} = V _{IL} or V _{IH} per Truth Table
		74		0.35	0.5	V	
I _{IH}	Input HIGH Current			20	μA	V _{CC} = MAX, V _{IN} = 2.7 V	
				0.1	mA	V _{CC} = MAX, V _{IN} = 7.0 V	
I _{IL}	Input LOW Current MS, MR CP ₀ CP ₁ (LS90, LS92) CP ₁ (LS93)			-0.4 -2.4 -3.2 -1.6	mA	V _{CC} = MAX, V _{IN} = 0.4 V	
I _{OS}	Short Circuit Current (Note 1)	-20		-100	mA	V _{CC} = MAX	
I _{CC}	Power Supply Current			15	mA	V _{CC} = MAX	

Note 1: Not more than one output should be shorted at a time, nor for more than 1 second.

SN54/74LS90 • SN54/74LS92 • SN54/74LS93

AC CHARACTERISTICS (T_A = 25°C, V_{CC} = 5.0 V, C_L = 15 pF)

Symbol	Parameter	Limits									Unit
		LS90			LS92			LS93			
		Min	Typ	Max	Min	Typ	Max	Min	Typ	Max	
f _{MAX}	\overline{CP}_0 Input Clock Frequency	32			32			32			MHz
f _{MAX}	\overline{CP}_1 Input Clock Frequency	16			16			16			MHz
t _{PLH} t _{PHL}	Propagation Delay, \overline{CP}_0 Input to Q ₀ Output		10 12	16 18		10 12	16 18		10 12	16 18	ns
t _{PLH} t _{PHL}	\overline{CP}_0 Input to Q ₃ Output		32 34	48 50		32 34	48 50		46 46	70 70	ns
t _{PLH} t _{PHL}	\overline{CP}_1 Input to Q ₁ Output		10 14	16 21		10 14	16 21		10 14	16 21	ns
t _{PLH} t _{PHL}	\overline{CP}_1 Input to Q ₂ Output		21 23	32 35		10 14	16 21		21 23	32 35	ns
t _{PLH} t _{PHL}	\overline{CP}_1 Input to Q ₃ Output		21 23	32 35		21 23	32 35		34 34	51 51	ns
t _{PLH}	MS Input to Q ₀ and Q ₃ Outputs		20	30							ns
t _{PHL}	MS Input to Q ₁ and Q ₂ Outputs		26	40							ns
t _{PHL}	MR Input to Any Output		26	40		26	40		26	40	ns

AC SETUP REQUIREMENTS (T_A = 25°C, V_{CC} = 5.0 V)

Symbol	Parameter	Limits						Unit
		LS90		LS92		LS93		
		Min	Max	Min	Max	Min	Max	
t _W	\overline{CP}_0 Pulse Width	15		15		15		ns
t _W	\overline{CP}_1 Pulse Width	30		30		30		ns
t _W	MS Pulse Width	15						ns
t _W	MR Pulse Width	15		15		15		ns
t _{rec}	Recovery Time MR to \overline{CP}	25		25		25		ns

RECOVERY TIME (t_{rec}) is defined as the minimum time required between the end of the reset pulse and the clock transition from HIGH-to-LOW in order to recognize and transfer HIGH data to the Q outputs

AC WAVEFORMS

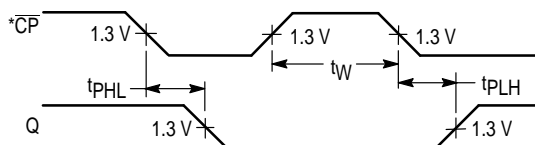

Figure 1

*The number of Clock Pulses required between the t_{PHL} and t_{PLH} measurements can be determined from the appropriate Truth Tables.

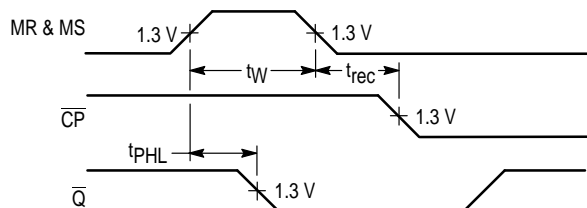

Figure 2

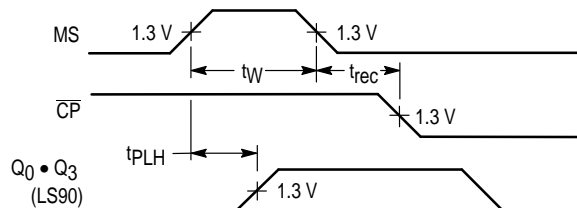

Figure 3