



LT3471

Dual 1.3A, 1.2MHz Boost/Inverter in 3mm x 3mm DFN

FEATURES

- 1.2MHz Switching Frequency
- Low V_{CESAT} Switches: 330mV at 1.3A
- High Output Voltage: Up to 40V
- Wide Input Range: 2.4V to 16V
- Inverting Capability
- 5V at 630mA from 3.3V Input
- 12V at 320mA from 5V Input
- -12V at 200mA from 5V Input
- Uses Tiny Surface Mount Components
- Low Shutdown Current: $<1\mu A$
- Low Profile (0.75mm) 10-Lead 3mm x 3mm DFN Package

APPLICATIONS

- Organic LED Power Supply
- Digital Cameras
- White LED Power Supply
- Cellular Phones
- Medical Diagnostic Equipment
- Local $\pm 5V$ or $\pm 12V$ Supply
- TFT-LCD Bias Supply
- xDSL Power Supply

DESCRIPTION

The LT[®]3471 dual switching regulator combines two 42V, 1.3A switches with error amplifiers that can sense to ground providing boost and inverting capability. The low V_{CESAT} bipolar switches enable the device to deliver high current outputs in a small footprint. The LT3471 switches at 1.2MHz, allowing the use of tiny, low cost and low profile inductors and capacitors. High inrush current at start-up is eliminated using the programmable soft-start function, where an external RC sets the current ramp rate. A constant frequency current mode PWM architecture results in low, predictable output noise that is easy to filter.

The LT3471 switches are rated at 42V, making the device ideal for boost converters up to $\pm 40V$ as well as SEPIC and flyback designs. Each channel can generate 5V at up to 630mA from a 3.3V supply, or 5V at 510mA from four alkaline cells in a SEPIC design. The device can be configured as two boosts, a boost and inverter or two inverters.

The LT3471 is available in a low profile (0.75mm) 10-lead 3mm x 3mm DFN package.

LT, LTC and LT are registered trademarks of Linear Technology Corporation.

TYPICAL APPLICATION

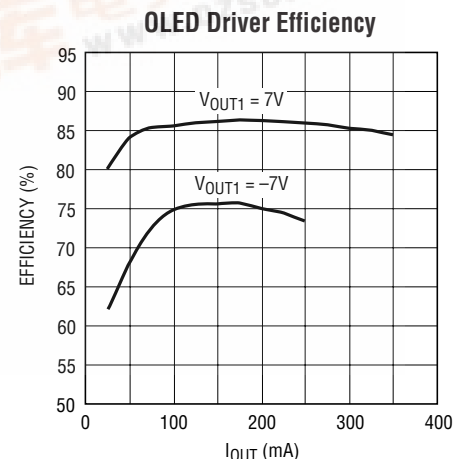
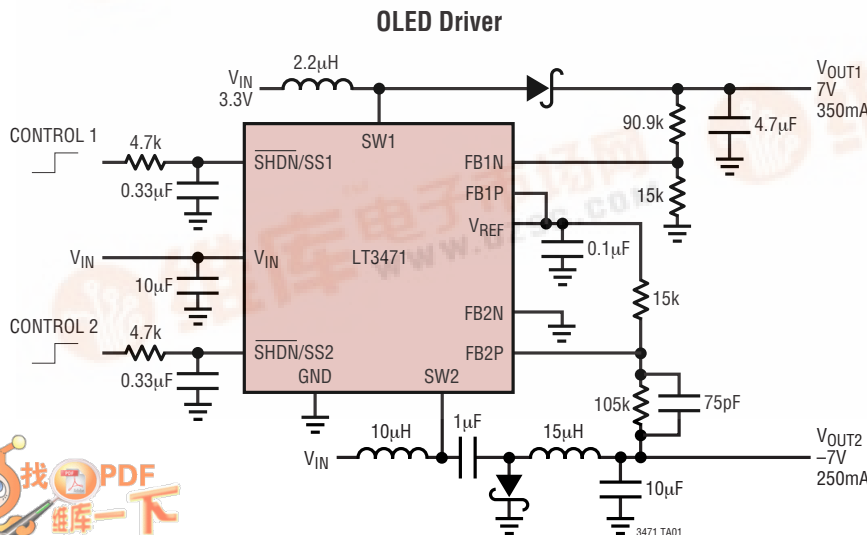

LT3471

ABSOLUTE MAXIMUM RATINGS

(Note 1)

V_{IN} Voltage	16V
SW1, SW2 Voltage	-0.4V to 42V
FB1N, FB1P, FB2N, FB2P Voltage	12V or $V_{IN} - 1.5V$
SHDN/SS1, SHDN/SS2 Voltage	16V
V_{REF} Voltage	1.5V
Maximum Junction Temperature	125°C
Operating Temperature Range (Note 2)	-40°C to 85°C
Storage Temperature Range	-65°C to 125°C

PACKAGE/ORDER INFORMATION

<p>DD PACKAGE 10-LEAD (3mm × 3mm) PLASTIC DFN $T_{JMAX} = 125^{\circ}C$, $\theta_{JA} = 43^{\circ}C/W$, $\theta_{JC} = 3^{\circ}C/W$ EXPOSED PAD (PIN 11) IS GND MUST BE SOLDERED TO PCB</p>	ORDER PART NUMBER
	LT3471EDD
	DD PART MARKING
	LBHM

Consult LTC Marketing for parts specified with wider operating temperature ranges.

ELECTRICAL CHARACTERISTICS

The ● denotes specifications which apply over the full operating temperature range, otherwise specifications are $T_A = 25^{\circ}C$. $V_{IN} = V_{SHDN} = 3V$ unless otherwise noted.

PARAMETER	CONDITIONS	MIN	TYP	MAX	UNITS
Minimum Operating Voltage			2.1	2.4	V
Reference Voltage		0.991 0.987	1.000	1.009 1.013	V V
Reference Voltage Current Limit	(Note 3)	● 1	1.4		mA
Reference Voltage Load Regulation	$0mA \leq I_{REF} \leq 100\mu A$ (Note 3)		0.1	0.2	%/100 μA
Reference Voltage Line Regulation	$2.6V \leq V_{IN} \leq 16V$		0.03	0.08	%/V
Error Amplifier Offset	Transition from Not Switching to Switching, $V_{FBP} = V_{FBN} = 1V$		±2	±3	mV
FB Pin Bias Current	(Note 3)	● 60	100		nA
Quiescent Current	$V_{SHDN} = 1.8V$, Not Switching		2.5	4	mA
Quiescent Current in Shutdown	$V_{SHDN} = 0.3V$, $V_{IN} = 3V$		0.01	1	μA
Switching Frequency		1	1.2	1.4	MHz
Maximum Duty Cycle		● 90 86	94		% %
Minimum Duty Cycle			15		%
Switch Current Limit	At Minimum Duty Cycle At Maximum Duty Cycle (Note 4)	1.5 0.9	2.05 1.45	2.6 2.0	A A
Switch V_{CESAT}	$I_{SW} = 1.3A$ (Note 5)		330	440	mV
Switch Leakage Current	$V_{SW} = 5V$		0.01	1	μA
SHDN/SS Input Voltage High		1.8			V
SHDN Input Voltage Low	Quiescent Current $\leq 1\mu A$			0.3	V
SHDN Pin Bias Current	$V_{SHDN} = 3V$, $V_{IN} = 4V$ $V_{SHDN} = 0V$		22 0	36 0.1	μA μA

Note 1: Absolute Maximum Ratings are those values beyond which the life of a device may be impaired.

Note 2: The LT3471E is guaranteed to meet performance specifications from 0°C to 70°C. Specifications over the -40°C to 85°C operating temperature range are assured by design, characterization and correlation with statistical process controls.

Note 3: Current flows out of the pin.

Note 4: See Typical Performance Characteristics for guaranteed current limit vs duty cycle.

Note 5: V_{CESAT} is 100% tested at wafer level.

TYPICAL PERFORMANCE CHARACTERISTICS

Quiescent Current vs Temperature

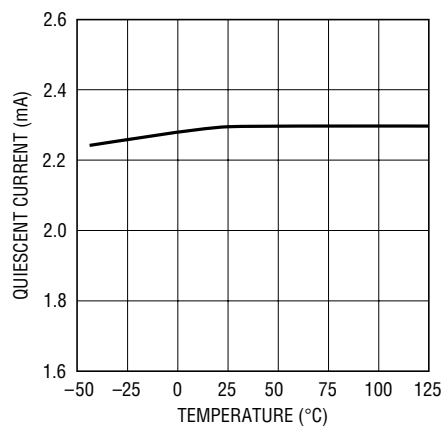

3471 G01

V_{REF} Voltage vs Temperature

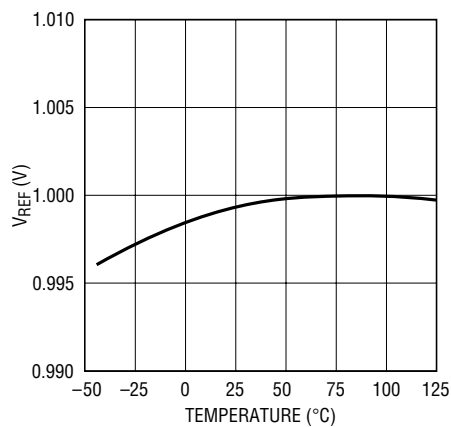

3471 G02

V_{REF} Voltage vs V_{REF} Current

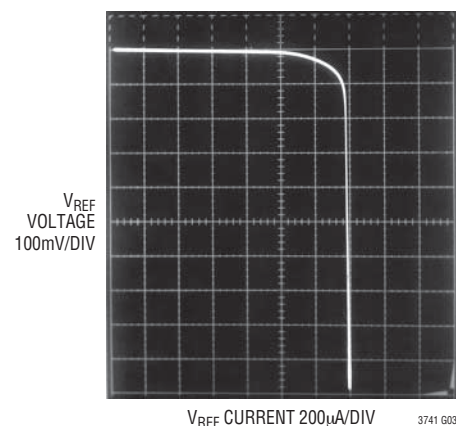

3471 G03

SHDN/SS Current vs SHDN/SS Voltage

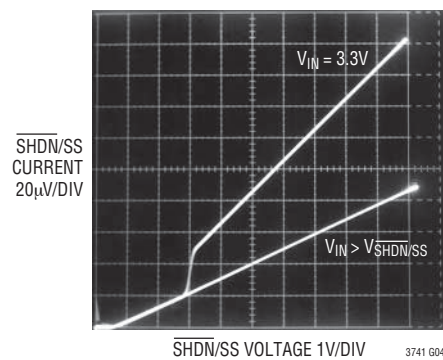

3471 G04

Current Limit vs Duty Cycle

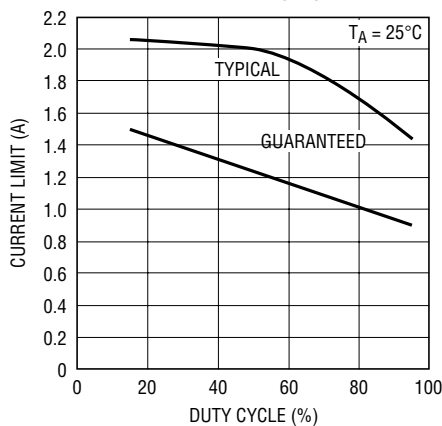

3471 G05

Switch Saturation Voltage vs Switch Current

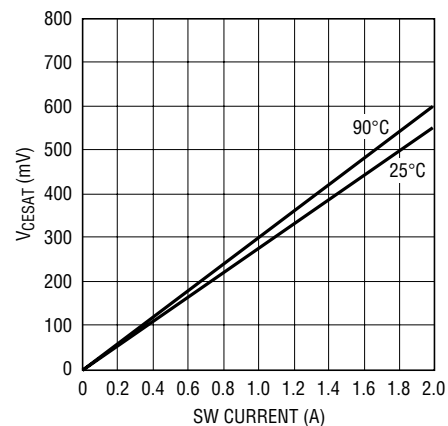

3471 G06

Oscillator Frequency vs Temperature

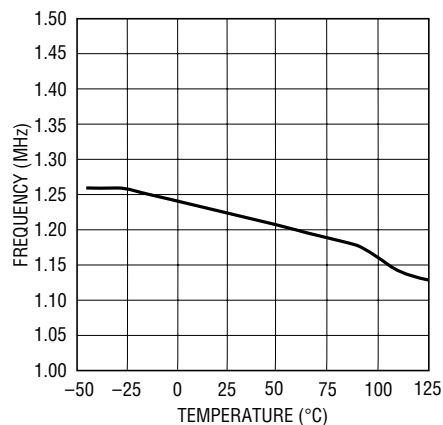

3471 G07

Peak Switch Current vs SHDN/SS Voltage

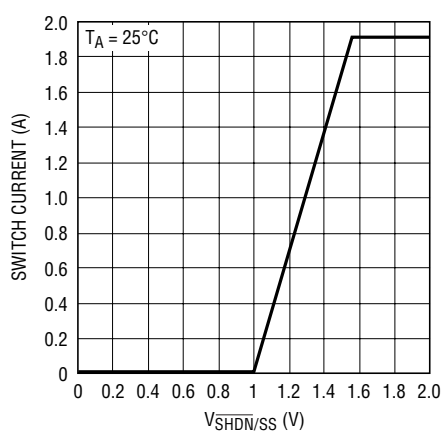

3471 G08

Start-Up Waveform (Figure 2 Circuit)

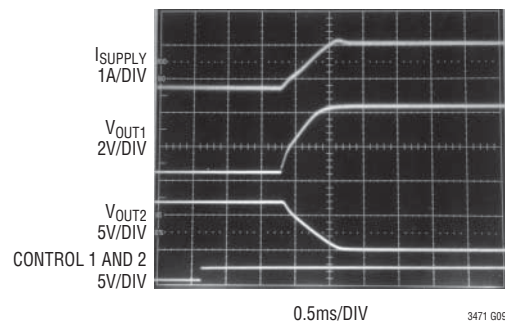

3471 G09

PIN FUNCTIONS

FB1N (Pin 1): Negative Feedback Pin for Switcher 1. Connect resistive divider tap here. Minimize trace area at FB1N. Set $V_{OUT} = V_{FB1P}(1 + R1/R2)$, or connect to ground for inverting topologies.

FB1P (Pin 2): Positive Feedback Pin for Switcher 1. Connect either to V_{REG} or a divided down version of V_{REG} , or connect to a resistive divider tap for inverting topologies.

V_{REF} (Pin 3): 1.00V Reference Pin. Can supply up to 1mA of current. Do not pull this pin high. Must be locally bypassed with *no less than 0.01μF and no more than 1μF*. A 0.1μF ceramic capacitor is recommended. Use this pin as the positive feedback reference or connect a resistor divider here for a smaller reference voltage.

FB2P (Pin 4): Same as FB1P but for Switcher 2.

FB2N (Pin 5): Same as FB1N but for Switcher 2.

SW2 (Pin 6): Switch Pin for Switcher 2 (Collector of internal NPN power switch). Connect inductor/diode here

and minimize the metal trace area connected to this pin to minimize EMI.

SHDN/SS2 (Pin 7): Shutdown and Soft-Start Pin. Tie to 1.8V or more to enable device. Ground to shut down. Soft-start function is provided when the voltage at this pin is ramped slowly to 1.8V with an external RC circuit.

V_{IN} (Pin 8): Input Supply. Must be locally bypassed.

SHDN/SS1 (Pin 9): Same as SHDN/SS2 but for Switcher 1. Note: taking either SHDN/SS pin high will enable the part. Each switcher is individually enabled with its respective SHDN/SS pin.

SW1 (Pin 10): Same as SW2 but for Switcher 1.

Exposed Pad (Pin 11): Ground. Connect directly to local ground plane. This ground plane also serves as a heat sink for optimal thermal performance.

BLOCK DIAGRAM

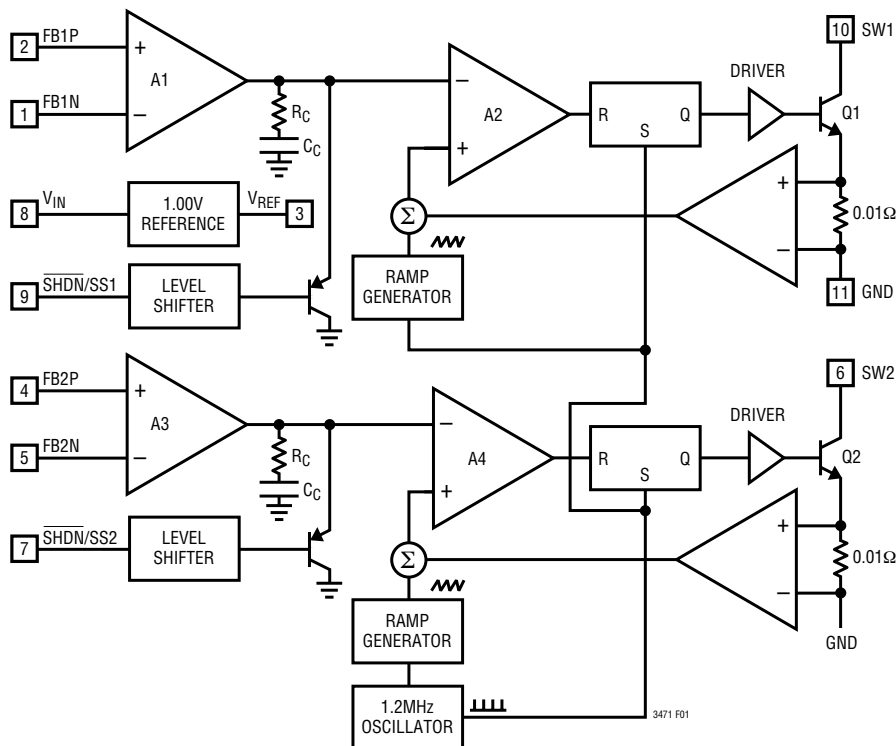

Figure 1. Block Diagram

OPERATION

The LT3471 uses a constant frequency, current mode control scheme to provide excellent line and load regulation. Refer to the Block Diagram. At the start of each oscillator cycle, the SR latch is set, which turns on the power switch, Q1 (Q2). A voltage proportional to the switch current is added to a stabilizing ramp and the resulting sum is fed into the positive terminal of the PWM comparator A2 (A4). When this voltage exceeds the level at the negative input of A2 (A4), the SR latch is reset, turning off the power switch Q1 (Q2). The level at the negative input of A2 (A4) is set by the error amplifier A1 (A3) and is simply an amplified version of the difference between the negative feedback voltage and the positive feedback voltage, usually tied to the reference voltage V_{REG} . In this manner, the error amplifier sets the correct peak current level to keep the output in regulation. If the error amplifier's output increases, more current is delivered to the output. Similarly, if the error decreases, less current is delivered. Each switcher functions independently but they share the same oscillator and thus the switchers are always in phase. Enabling the part is done by

taking either $\overline{SHDN/SS}$ pin above 1.8V. Disabling the part is done by grounding both SHDN/SS pins. The soft-start feature of the LT3471 allows for clean start-up conditions by limiting the amount of voltage rise at the output of comparator A1 and A2, which in turn limits the peak switching current. The soft-start feature for each switcher is enabled by slowly ramping that switcher's $\overline{SHDN/SS}$ pin, using an RC network, for example. Typical resistor and capacitor values are 0.33 μ F and 4.7k Ω , allowing for a start-up time on the order of milliseconds. The LT3471 has a current limit circuit not shown in the Block Diagram. The switch current is constantly monitored and not allowed to exceed the maximum switch current (typically 1.6A). If the switch current reaches this value, the SR latch is reset regardless of the state of the comparator A2 (A4). Also not shown in the Block Diagram is the thermal shutdown circuit. If the temperature of the part exceeds approximately 160°C, both latches are reset regardless of the state of comparators A2 and A4. The current limit and thermal shutdown circuits protect the power switch as well as the external components connected to the LT3471.

APPLICATIONS INFORMATION

Duty Cycle

The typical maximum duty cycle of the LT3471 is 94%. The duty cycle for a given application is given by:

$$DC = \frac{|V_{OUT}| + |V_D| - |V_{IN}|}{|V_{OUT}| + |V_D| - |V_{CESAT}|}$$

Where V_D is the diode forward voltage drop and V_{CESAT} is in the worst case 330mV (at 1.3A)

The LT3471 can be used at higher duty cycles, but it must be operated in the discontinuous conduction mode so that the actual duty cycle is reduced.

Setting Output Voltage

Setting the output voltage depends on the topology used. For normal noninverting boost regulator topologies:

$$V_{OUT} = V_{FBP} \left(1 + \frac{R1}{R2} \right)$$

where V_{FBN} is connected between R1 and R2 (see the Typical Applications section for examples).

Select values of R1 and R2 according to the following equation:

$$R1 = R2 \left(\frac{V_{OUT}}{V_{REF} - 1} \right)$$

A good value for R2 is 15k which sets the current in the resistor divider chain to 1.00V/15k = 67 μ A.

V_{FBP} is usually just tied to $V_{REF} = 1.00$ V, but V_{FBP} can also be tied to a divided down version of V_{REF} or some other voltage as long as the absolute maximum ratings for the feedback pins are not exceeded (see Absolute Maximum Ratings).

For inverting topologies, V_{FBN} is tied to ground and V_{FBP} is connected between R1 and R2. R2 is between V_{FBP} and

APPLICATIONS INFORMATION

V_{REF} and R1 is between V_{FBP} and V_{OUT} (see the Applications section for examples). In this case:

$$V_{OUT} = V_{REF} \left(\frac{R1}{R2} \right)$$

Select values of R1 and R2 according to the following equation:

$$R1 = R2 \left(\frac{V_{OUT}}{V_{REF}} \right)$$

A good value for R2 is 15k, which sets the current in the resistor divider chain to $1.00V/15k = 67\mu A$.

Switching Frequency and Inductor Selection

The LT3471 switches at 1.2 MHz, allowing for small valued inductors to be used. 4.7 μH or 10 μH will usually suffice. Choose an inductor that can handle at least 1.4A without saturating, and ensure that the inductor has a low DCR (copper-wire resistance) to minimize I^2R power losses. Note that in some applications, the current handling requirements of the inductor can be lower, such as in the SEPIC topology where each inductor only carries one half of the total switch current. For better efficiency, use similar valued inductors with a larger volume. Many different sizes and shapes are available from various manufacturers. Choose a core material that has low losses at 1.2 MHz, such as ferrite core.

Table 1. Inductor Manufacturers

Sumida	(847) 956-0666	www.sumida.com
TDK	(847) 803-6100	www.tdk.com
Murata	(714) 852-2001	www.murata.com

Soft-Start and Shutdown Features

To shut down the part, ground both $\overline{SHDN/SS}$ pins. To shut down one switcher but not the other one, ground that switcher's $\overline{SHDN/SS}$ pin. The soft-start feature provides a way to limit the inrush current drawn from the supply upon start-up. To use the soft-start feature for either switcher, slowly ramp up that switcher's $\overline{SHDN/SS}$ pin. The rate of voltage rise at the output of the switcher's comparator (A1 or A3 for switcher 1 or switcher 2 respectively) tracks the rate of voltage rise at the $\overline{SHDN/SS}$ pin once the $\overline{SHDN/SS}$

pin has reached about 1.1V. The soft-start function will go away once the voltage at the $\overline{SHDN/SS}$ pin exceeds 1.8V. See the Peak Switch Current vs $\overline{SHDN/SS}$ Voltage graph in the Typical Performance Characteristics section. The rate of voltage rise at the $\overline{SHDN/SS}$ pin can easily be controlled with a simple RC network connected between the control signal and the $\overline{SHDN/SS}$ pin. Typical values for the RC network are 4.7k Ω and 0.33 μF , giving start-up times on the order of milliseconds. This RC time constant can be adjusted to give different start-up times. If different values of resistance are to be used, keep in mind the $\overline{SHDN/SS}$ Current vs $\overline{SHDN/SS}$ voltage graph along with the Peak Switch Current vs $\overline{SHDN/SS}$ Voltage graph, both found in the Typical Performance Characteristics section. The impedance looking into the $\overline{SHDN/SS}$ pin depends on whether the $\overline{SHDN/SS}$ is above or below V_{IN} . Normally $\overline{SHDN/SS}$ will not be driven above V_{IN} , and thus the impedance looks like 100k Ω in series with a diode. If the voltage of the $\overline{SHDN/SS}$ pin is above V_{IN} , the impedance looks more like 50k Ω in series with a diode. This 100k Ω or 50k Ω impedance can have a slight effect on the start-up time if you choose the R in the RC soft-start network too large. Another consideration is selecting the soft-start time so that the soft-start feature is dominated by the RC network and not the capacitor on V_{REF} . (See V_{REF} voltage reference section of the Applications Information for details.)

CAPACITOR SELECTION

Low ESR (equivalent series resistance) capacitors should be used at the output to minimize the output ripple voltage. Multi-layer ceramic capacitors are an excellent choice, as they have extremely low ESR and are available in very small packages. X5R dielectrics are preferred, followed by X7R, as these materials retain the capacitance over wide voltage and temperature ranges. A 4.7 μF to 15 μF output capacitor is sufficient for most applications, but systems with very low output currents may need only a 1 μF or 2.2 μF output capacitor. Solid tantalum or OS-CON capacitors can be used, but they will occupy more board area than a ceramic and will have a higher ESR. Always use a capacitor with a sufficient voltage rating.

Ceramic capacitors also make a good choice for the input decoupling capacitor, which should be placed as close as possible to the LT3471. A 4.7 μF to 10 μF input capacitor is

APPLICATIONS INFORMATION

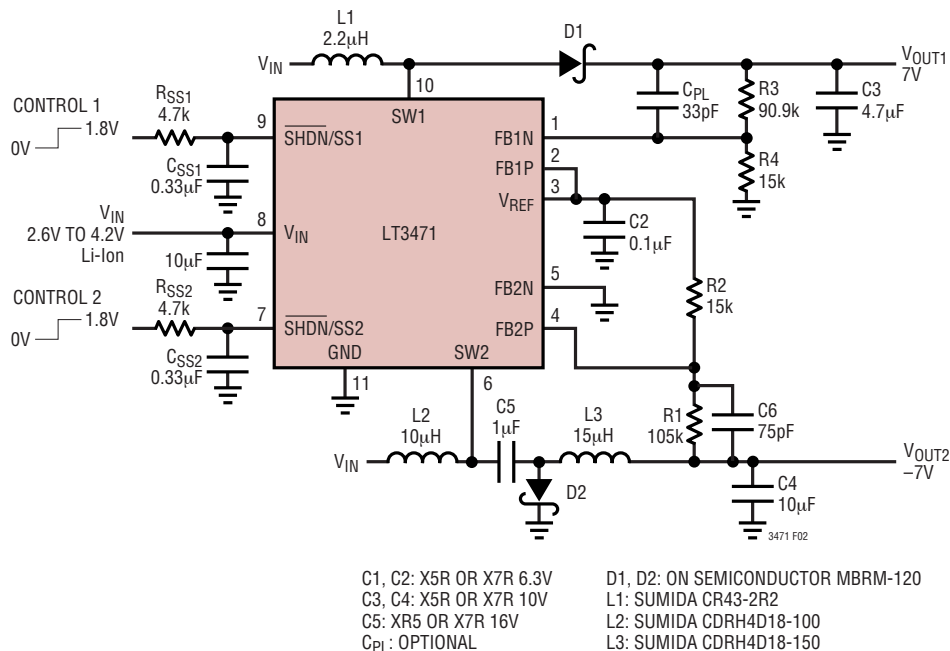
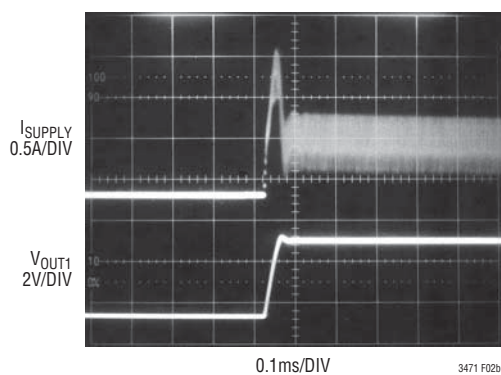
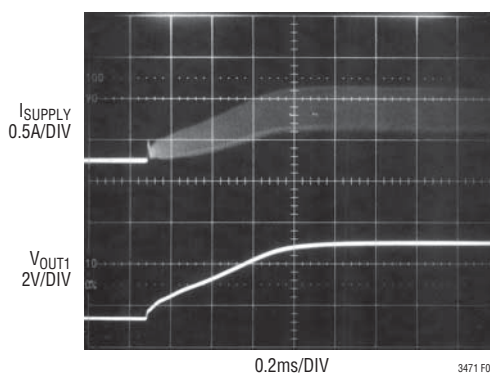

Figure 2. Li-Ion OLED Driver

Supply Current of Figure 2 During Start-Up without Soft-Start RC Network



Supply Current of Figure 2 During Start-Up with Soft-Start RC Network



sufficient for most applications. Table 2 shows a list of several ceramic capacitor manufacturers. Consult the manufacturers for detailed information on their entire selection of ceramic parts.

Table 2. Ceramic Capacitor Manufacturers

Taiyo Yuden	(408) 573-4150	www.t-yuden.com
AVX	(803) 448-9411	www.avxcorp.com
Murata	(714) 852-2001	www.murata.com

The decision to use either low ESR (ceramic) capacitors or the higher ESR (tantalum or OS-CON) capacitors can

affect the stability of the overall system. The ESR of any capacitor, along with the capacitance itself, contributes a zero to the system. For the tantalum and OS-CON capacitors, this zero is located at a lower frequency due to the higher value of the ESR, while the zero of a ceramic capacitor is at a much higher frequency and can generally be ignored.

A phase lead zero can be intentionally introduced by placing a capacitor (C_{PL}) in parallel with the resistor ($R3$) between V_{OUT} and V_{FB} as shown in Figure 2. The frequency of the zero is determined by the following equation.

APPLICATIONS INFORMATION

$$f_z = \frac{1}{2\pi \cdot R_3 \cdot C_{PL}}$$

By choosing the appropriate values for the resistor and capacitor, the zero frequency can be designed to improve the phase margin of the overall converter. The typical target value for the zero frequency is between 35kHz to 55kHz. Figure 3 shows the transient response of the step-up converter from Figure 2 without the phase lead capacitor C_{PL} . Although adequate for many applications, phase margin is not ideal as evidenced by 2-3 “bumps” in both the output voltage and inductor current. A 33pF capacitor for C_{PL} results in ideal phase margin, which is revealed in Figure 4 as a more damped response and less overshoot.

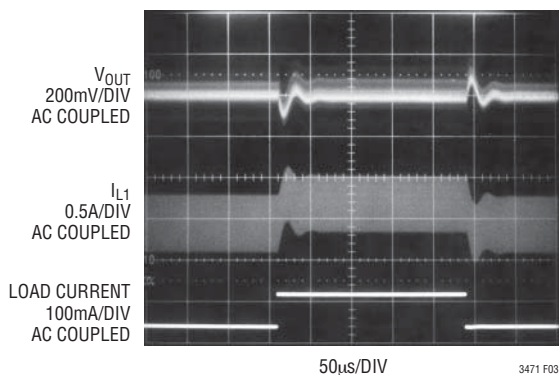

Figure 3. Transient Response of Figure 2’s Step-Up Converter without Phase Lead Capacitor

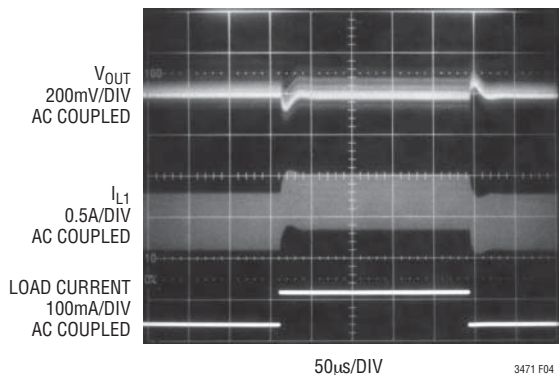

Figure 4. Transient Response of Figure 2’s Step-Up Converter with 33pF Phase Lead Capacitor

V_{REG} VOLTAGE REFERENCE

Pin 3 of the LT3471 is a bandgap voltage reference that has been divided down to 1.00V and buffered for external use. This pin must be bypassed with at least 0.01µF and no more than 1µF. This will ensure stability as well as reduce the noise on this pin. The buffer has a built-in current limit of at least 1mA (typically 1.4mA). This not only means that you can use this pin as an external reference for supplemental circuitry, but it also means that it is possible to provide a soft-start feature if this pin is used as one of the feedback pins for the error amplifier. Normally the soft-start time will be dominated by the RC time constant discussed in the soft-start and shutdown section. However, because of the finite current limit of the buffer for the V_{REG} pin, it will take some time to charge up the bypass capacitor. During this time, the voltage at the V_{REG} pin will ramp up, and this action provides an alternate means for soft-starting the circuit. If the largest recommended bypass capacitor is used, 1µF, the worst-case (longest) soft-start function that would be provided from the V_{REF} pin is:

$$\frac{1\mu\text{F} \cdot 1.00\text{V}}{1.0\text{mA}} = 1.0\text{ms}$$

Choose the RC network such that the soft-start time is longer than this time, or choose a smaller bypass capacitor for the V_{REF} pin (but always larger than 0.01µF) so that the RC network dominates the soft-starting of the LT3471. The voltage at the V_{REF} pin can also be divided down and used for one of the feedback pins for the error amplifier. This is especially useful in LED driver applications, where the current through the LEDs is set using the voltage reference across a sense resistor in the LED chain. Using a smaller or divided down reference leads to less wasted power in the sense resistor. See the Typical Applications section for an example of LED driving applications.

DIODE SELECTION

A Schottky diode is recommended for use with the LT3471. For high efficiency, a diode with good thermal characteristics at high currents should be used such as the On

APPLICATIONS INFORMATION

Semiconductor MBRM120. This is a 20V diode. Where the switch voltage exceeds 20V, use the MBRM140, a 40V diode. These diodes are rated to handle an average forward current of 1.0A. In applications where the average forward current of the diode is less than 0.5A, use the Philips PMEG 2005, 3005, or 4005 (a 20V, 30V or 40V diode, respectively).

LAYOUT HINTS

The high speed operation of the LT3471 demands careful attention to board layout. You will not get advertised performance with careless layout. Figure 5 shows the recommended component placement.

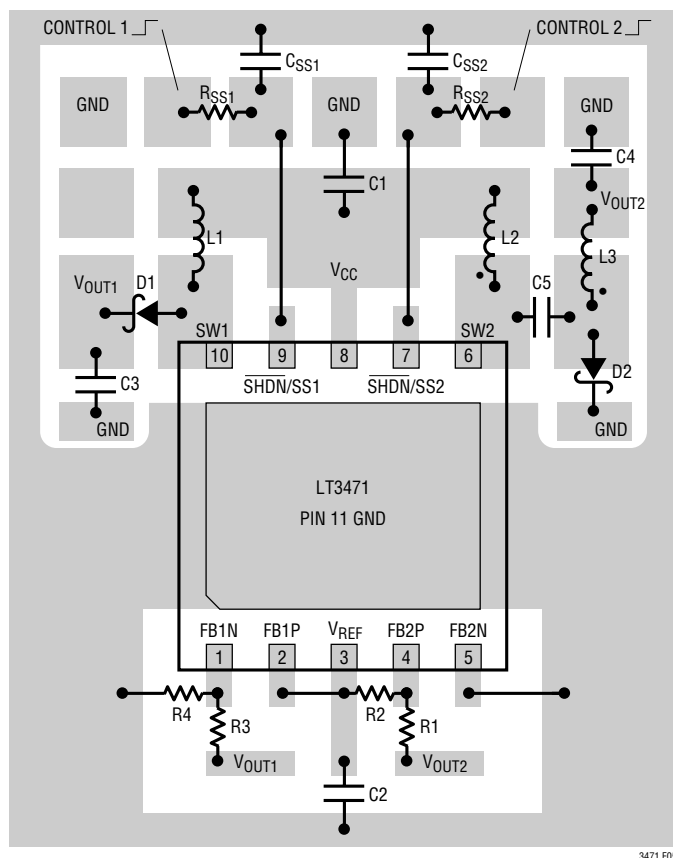

Figure 5. Suggested Layout Showing a Boost on SW1 and an Inverter on SW2. Note the Separate Ground Returns for All High Current Paths (Using a Multilayer Board)

Compensation—Theory

Like all other current mode switching regulators, the LT3471 needs to be compensated for stable and efficient operation. Two feedback loops are used in the LT3471: a fast current loop which does not require compensation, and a slower voltage loop which does. Standard Bode plot analysis can be used to understand and adjust the voltage feedback loop.

As with any feedback loop, identifying the gain and phase contribution of the various elements in the loop is critical. Figure 6 shows the key equivalent elements of a boost converter. Because of the fast current control loop, the power stage of the IC, inductor and diode have been replaced by the equivalent transconductance amplifier g_{mp} . g_{mp} acts as a current source where the output current is proportional to the V_C voltage. Note that the maximum output current of g_{mp} is finite due to the current limit in the IC.

From Figure 6, the DC gain, poles and zeroes can be calculated as follows:

$$\text{Output Pole: } P1 = \frac{2}{2 \cdot \pi \cdot R_L \cdot C_{OUT}}$$

$$\text{Error Amp Pole: } P2 = \frac{1}{2 \cdot \pi \cdot R_O \cdot C_C}$$

$$\text{Error Amp Zero: } Z1 = \frac{1}{2 \cdot \pi \cdot R_C \cdot C_C}$$

$$\text{DC GAIN: } A = \frac{V_{REF}}{V_{OUT}} \cdot g_{ma} \cdot R_O \cdot g_{mp} \cdot R_L \cdot \frac{1}{2}$$

$$\text{ESR Zero: } Z2 = \frac{1}{2 \cdot \pi \cdot R_{ESR} \cdot C_{OUT}}$$

$$\text{RHP Zero: } Z3 = \frac{V_{IN}^2 \cdot R_L}{2 \cdot \pi \cdot V_{OUT}^2 \cdot L}$$

$$\text{High Frequency Pole: } P3 > \frac{f_s}{3}$$

$$\text{Phase Lead Zero: } Z4 = \frac{1}{2 \cdot \pi \cdot R1 \cdot C_{PL}}$$

$$\text{Phase Lead Pole: } P4 = \frac{1}{2 \cdot \pi \cdot C_{PL} \cdot \frac{R1 \cdot R2}{R1 + R2}}$$

APPLICATIONS INFORMATION

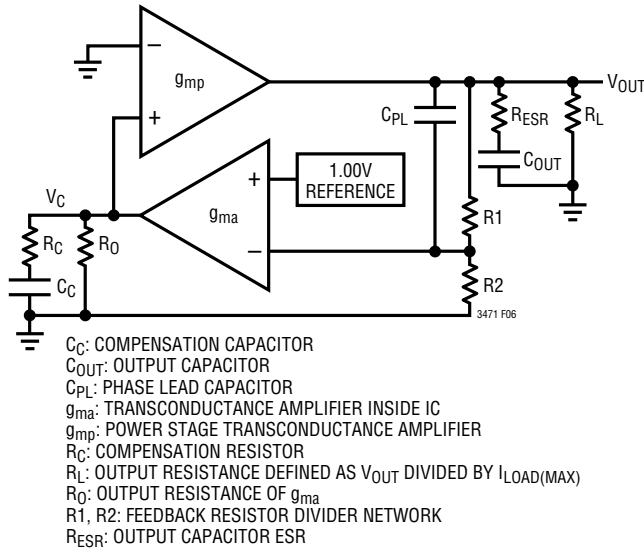

Figure 6. Boost Converter Equivalent Model

The Current Mode zero is a right half plane zero which can be an issue in feedback control design, but is manageable with proper external component selection.

Using the circuit of Figure 2 as an example, Table 3 shows the parameters used to generate the Bode plot shown in Figure 7.

Table 3. Bode Plot Parameters

Parameter	Value	Units	Comment
R_L	20	Ω	Application Specific
C_{OUT}	4.7	μF	Application Specific
R_{ESR}	10	$m\Omega$	Application Specific
R_O	0.9	$M\Omega$	Not Adjustable
C_C	90	μF	Not Adjustable
C_{PL}	33	μF	Adjustable
R_C	55	$k\Omega$	Not Adjustable
$R1$	90.9	$k\Omega$	Adjustable
$R2$	15	$k\Omega$	Adjustable
V_{OUT}	7	V	Application Specific
V_{IN}	3.3	V	Application Specific
g_{ma}	50	μmho	Not Adjustable
g_{mp}	9.3	mho	Not Adjustable
L	2.2	μH	Application Specific
f_S	1.2	MHz	Not Adjustable

From Figure 7, the phase is -115° when the gain reaches 0dB giving a phase margin of 65° . This is more than adequate. The crossover frequency is 50kHz.

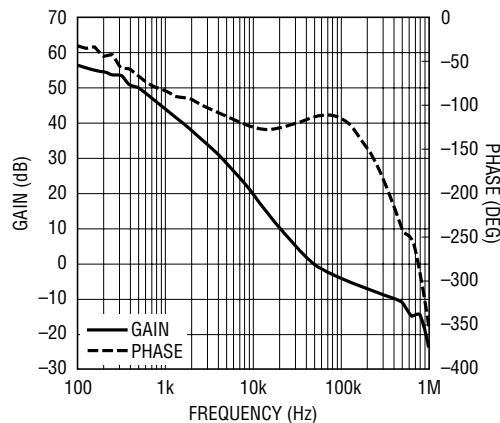
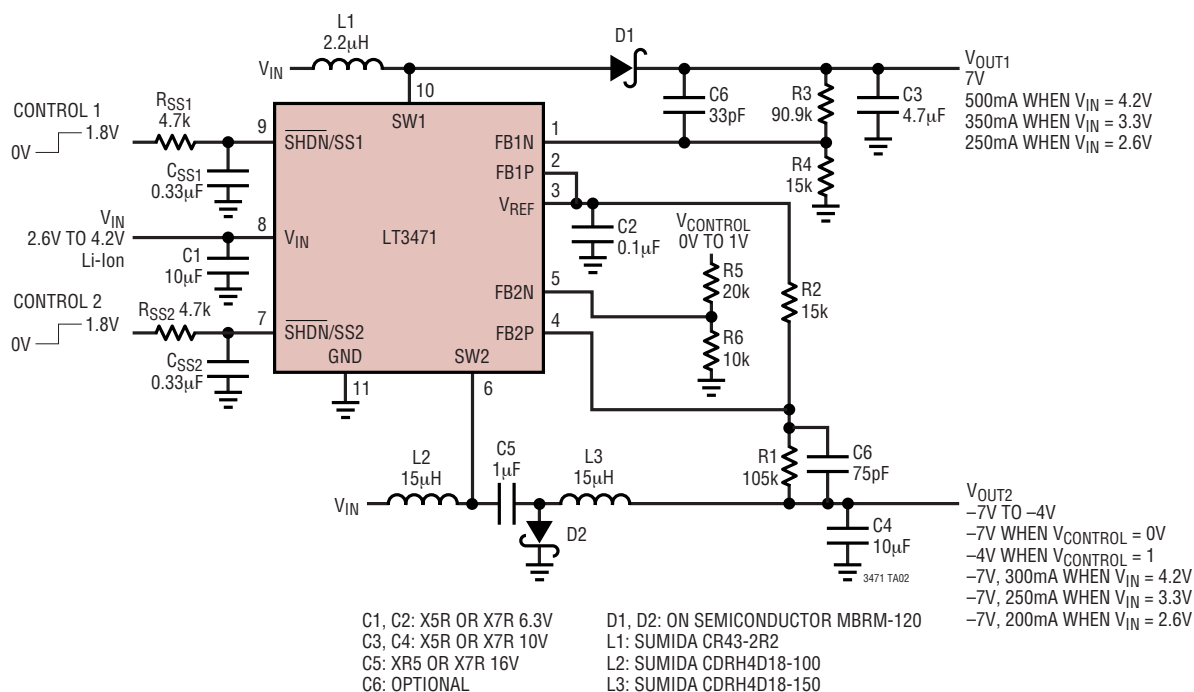

Figure 7. Bode Plot of 3.3V to 7V Application

TYPICAL APPLICATIONS

Li-Ion OLED Driver



Li-Ion OLED Driver Efficiency

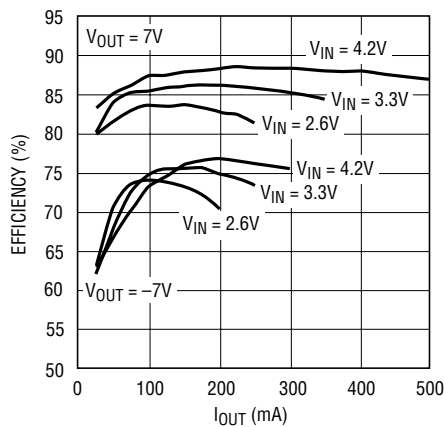

3471 TA02b

LT3471

TYPICAL APPLICATIONS

Single Li-Ion Cell to 5V, 12V Boost Converter

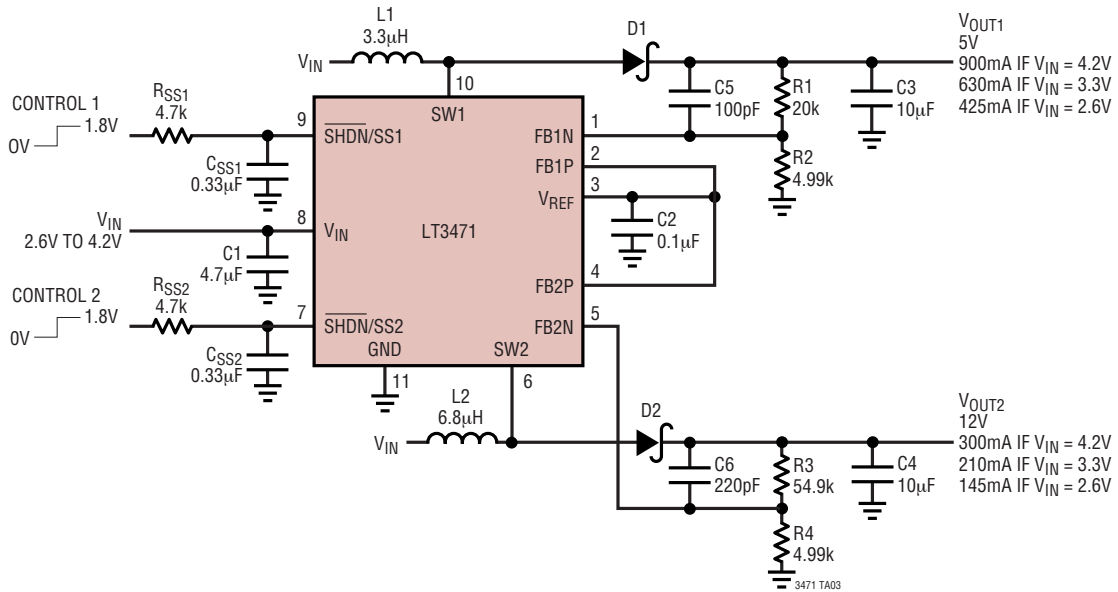

C1-C3: X5R OR X7R 6.3V
 C4: X5R OR X7R 16V
 C5: X5R OR X7R 6.3V
 C6: X5R OR X7R 16V
 D1, D2: ON SEMICONDUCTOR MBRM-120

L1: SUMIDA CR43-3R3
 L2: SUMIDA CR43-6R8

TYPICAL APPLICATIONS

Li-Ion 20 White LED Driver

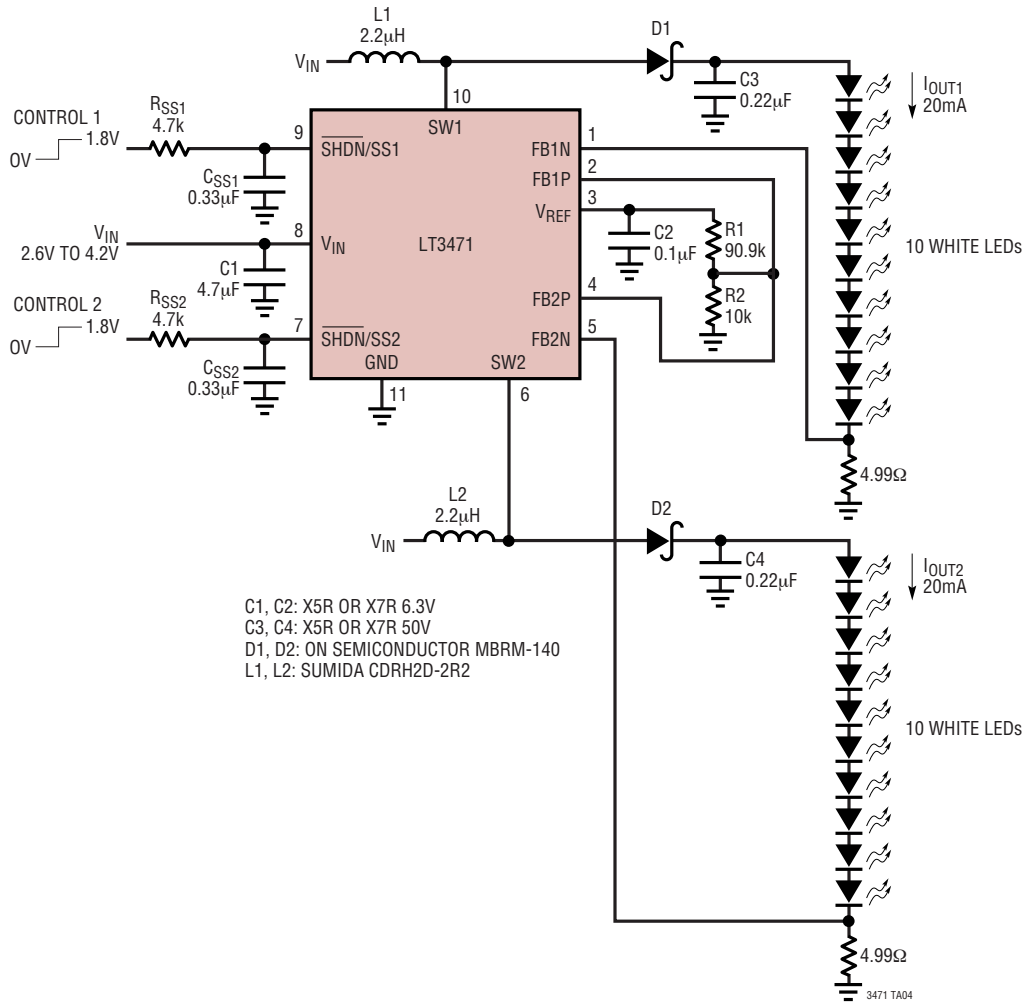

LT3471

TYPICAL APPLICATIONS

Li-Ion or 4-Cell Alkaline to 3.3V and 5V SEPIC

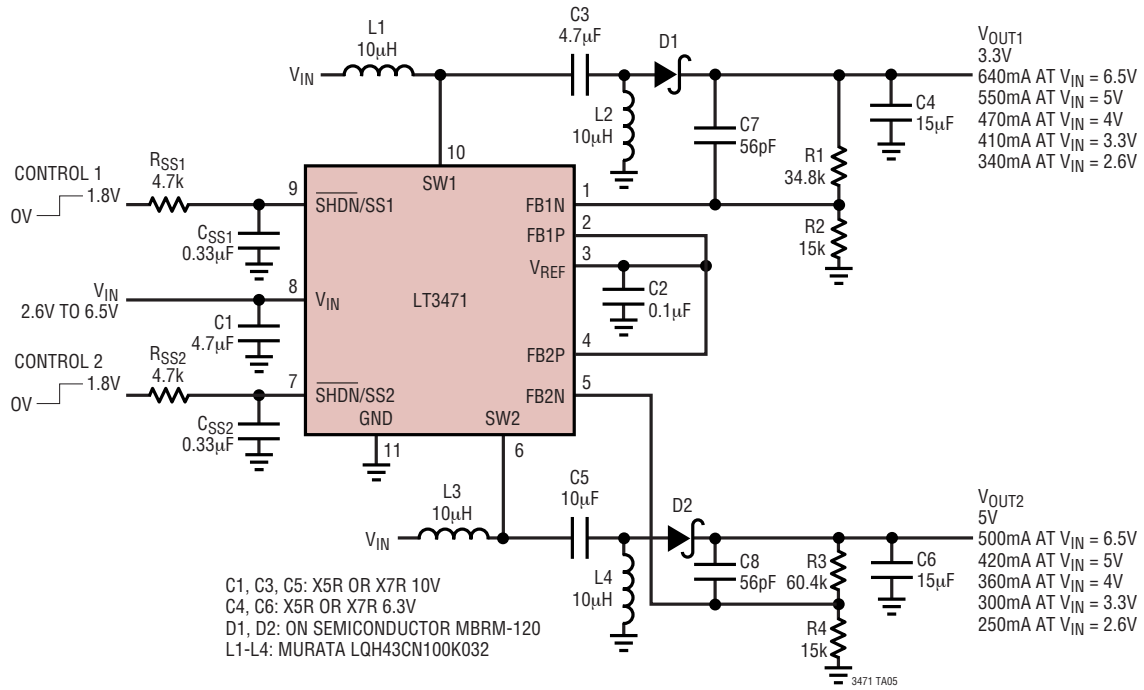

PACKAGE DESCRIPTION

DD Package
10-Lead Plastic DFN (3mm × 3mm)
 (Reference LTC DWG # 05-08-1698)

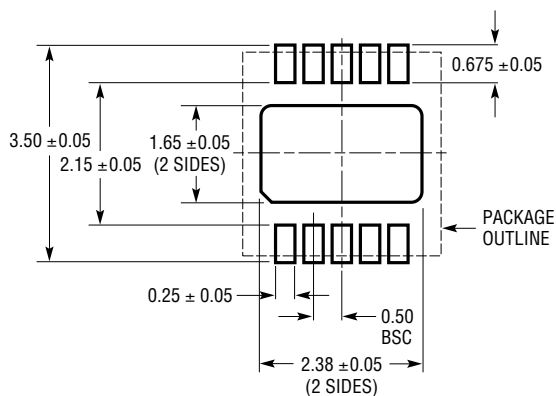

RECOMMENDED SOLDER PAD PITCH AND DIMENSIONS

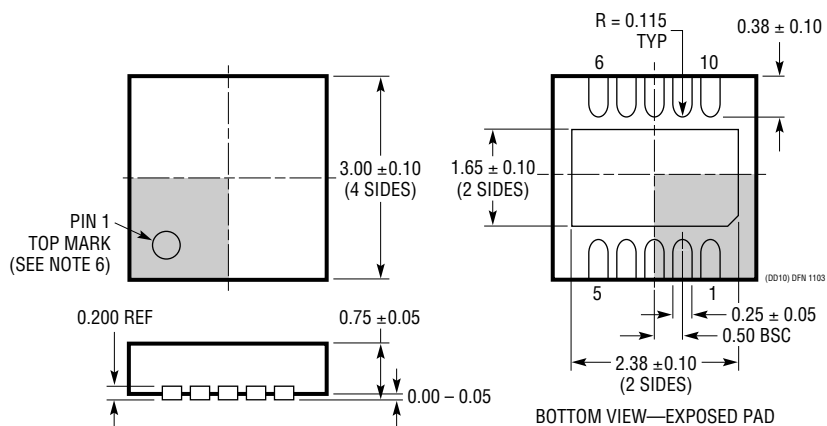

NOTE:

1. DRAWING TO BE MADE A JEDEC PACKAGE OUTLINE M0-229 VARIATION OF (WEED-2). CHECK THE LTC WEBSITE DATA SHEET FOR CURRENT STATUS OF VARIATION ASSIGNMENT
2. DRAWING NOT TO SCALE
3. ALL DIMENSIONS ARE IN MILLIMETERS
4. DIMENSIONS OF EXPOSED PAD ON BOTTOM OF PACKAGE DO NOT INCLUDE MOLD FLASH. MOLD FLASH, IF PRESENT, SHALL NOT EXCEED 0.15mm ON ANY SIDE
5. EXPOSED PAD SHALL BE SOLDER PLATED
6. SHADED AREA IS ONLY A REFERENCE FOR PIN 1 LOCATION ON THE TOP AND BOTTOM OF PACKAGE

LT3471

TYPICAL APPLICATION

5V to $\pm 12V$ Dual Supply Boost/Inverting Converter

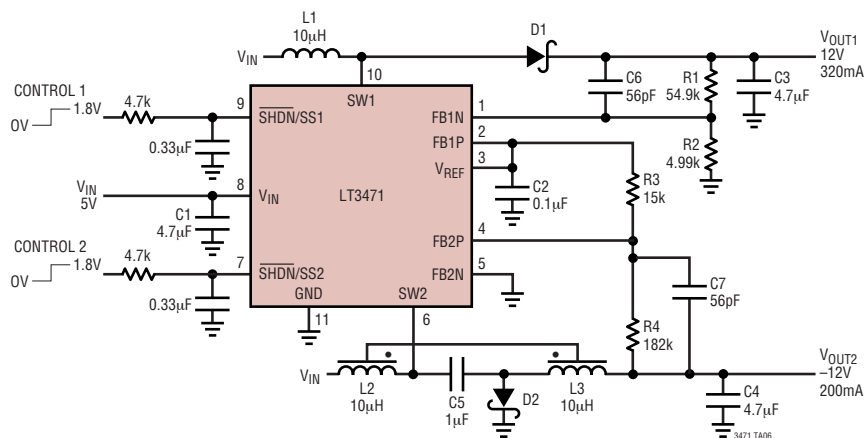

C1, C2: X5R OR X7R 6.3V
 C3, C4: X5R OR X7R 16V
 C5: X5R OR X7R 25V
 D1, D2: ON SEMICONDUCTOR MBRM-120

L1: SUMIDA CR43-10
 L2, L3: SUMIDA CLS63-10

RELATED PARTS

PART NUMBER	DESCRIPTION	COMMENTS
LT1611	550mA (I_{SW}), 1.4MHz, High Efficiency Micropower Inverting DC/DC Converter	V_{IN} : 1.1V to 10V, $V_{OUT(MAX)}$ = -34V, I_Q = 3mA, I_{SD} < 1 μ A, ThinSOT Package
LT1613	550mA (I_{SW}), 1.4MHz, High Efficiency Step-Up DC/DC Converter	V_{IN} : 0.9V to 10V, $V_{OUT(MAX)}$ = 34V, I_Q = 3mA, I_{SD} < 1 μ A, ThinSOT Package
LT1614	750mA (I_{SW}), 600kHz, High Efficiency Micropower Inverting DC/DC Converter	V_{IN} : 1V to 12V, $V_{OUT(MAX)}$ = -24V, I_Q = 1mA, I_{SD} < 10 μ A, MS8, S8 Packages
LT1615/LT1615-1	300mA/80mA (I_{SW}), High Efficiency Step-Up DC/DC Converters	V_{IN} = 1V to 15V, $V_{OUT(MAX)}$ = 34V, I_Q = 20 μ A, I_{SD} < 1 μ A, ThinSOT Package
LT1617/LT1617-1	350mA/100mA (I_{SW}), High Efficiency Micropower Inverting DC/DC Converters	V_{IN} = 1.2V to 15V, $V_{OUT(MAX)}$ = -34V, I_Q = 20 μ A, I_{SD} < 1 μ A, ThinSOT Package
LT1930/LT1930A	1A (I_{SW}), 1.2MHz/2.2MHz, High Efficiency Step-Up DC/DC Converters	V_{IN} : 2.6V to 16V, $V_{OUT(MAX)}$ = 34V, I_Q = 4.2mA/5.5mA, I_{SD} < 1 μ A, ThinSOT Package
LT1931/LT1931A	1A (I_{SW}), 1.2MHz/2.2MHz High Efficiency Micropower Inverting DC/DC Converters	V_{IN} = 2.6V to 16V, $V_{OUT(MAX)}$ = -34V, I_Q = 5.8mA, I_{SD} < 1 μ A, ThinSOT Package
LT1943 (Quad)	Quad Boost, 2.6A Buck, 2.6A Boost, 0.3A Boost, 0.4A Inverter 1.2MHz TFT DC/DC Converter	V_{IN} = 4.5V to 22V, $V_{OUT(MAX)}$ = 40V, I_Q = 10 μ A, I_{SD} < 35 μ A, TSSOP28E Package
LT1945 (Dual)	Dual Output, Boost/Inverter, 350mA (I_{SW}), Constant Off-Time, High Efficiency Step-Up DC/DC Converter	V_{IN} = 1.2V to 15V, $V_{OUT(MAX)}$ = $\pm 34V$, I_Q = 40 μ A, I_{SD} < 1 μ A, 10-Lead MS Package
LT1946/LT1946A	1.5A (I_{SW}), 1.2MHz/2.7MHz, High Efficiency Step-Up DC/DC Converters	V_{IN} : 2.45V to 16V, $V_{OUT(MAX)}$ = 34V, I_Q = 3.2mA, I_{SD} < 1 μ A, MS8 Package
LT3436	3A (I_{SW}), 1MHz, 34V Step-Up DC/DC Converter	V_{IN} : 3V to 25V, $V_{OUT(MAX)}$ = 34V, I_Q = 0.9mA, I_{SD} < 6 μ A, TSSOP16E Package
LT3462/LT3462A	300mA (I_{SW}), 1.2MHz/2.7MHz, High Efficiency Inverting DC/DC Converters with Integrated Schottkys	V_{IN} = 2.5V to 16V, $V_{OUT(MAX)}$ = -38V, I_Q = 2.9mA, I_{SD} < 1 μ A, ThinSOT Package
LT3463/LT3463A	Dual Output, Boost/Inverter, 250mA (I_{SW}), Constant Off-Time, High Efficiency Step-Up DC/DC Converters with Integrated Schottkys	V_{IN} = 2.3V to 15V, $V_{OUT(MAX)}$ = $\pm 40V$, I_Q = 40 μ A, I_{SD} < 1 μ A, DFN Package
LT3464	85mA (I_{SW}), High Efficiency Step-Up DC/DC Converter with Integrated Schottky and PNP Disconnect	V_{IN} = 2.3V to 10V, $V_{OUT(MAX)}$ = 34V, I_Q = 25 μ A, I_{SD} < 1 μ A, ThinSOT Package