



LTC1051/LTC1053

Dual/Quad Precision Chopper Stabilized Operational Amplifiers With Internal Capacitors

FEATURES

- Dual/Quad Low Cost Precision Op Amp
- No External Components Required
- Maximum Offset Voltage 5 μ V
- Maximum Offset Voltage Drift 0.05 μ V/ $^{\circ}$ C
- Low Noise 1.5 μ V_{p-p} (0.1Hz to 10Hz)
- Minimum Voltage Gain, 120dB
- Minimum PSRR, 120dB
- Minimum CMRR, 114dB
- Low Supply Current 1mA/Op Amp
- Single Supply Operation 4.75V to 16V
- Input Common Mode Range Includes Ground
- Output Swings to Ground
- Typical Overload Recovery Time 3ms
- Pin Compatible with Industry Standard Dual and Quad Op Amps

APPLICATIONS

- Thermocouple Amplifiers
- Electronic Scales
- Medical Instrumentation
- Strain Gauge Amplifiers
- High Resolution Data Acquisition
- DC Accurate R, C Active Filters

DESCRIPTION

The LTC1051/LTC1053 is a high performance, low cost dual/quad chopper stabilized operational amplifier. The unique achievement of the LTC1051/LTC1053 is that it integrates on chip the sample-and-hold capacitors usually required externally by other chopper amplifiers. Further, the LTC1051/LTC1053 offers better combined overall DC and AC performance than is available from other chopper stabilized amplifiers with or without internal sample/hold capacitors

The LTC1051/LTC1053 has an offset voltage of 0.5 μ V, drift of 0.01 μ V/ $^{\circ}$ C, DC to 10Hz, input noise voltage typically 1.5 μ V_{p-p} and typical voltage gain of 140dB. The slew rate of 4V/ μ s and gain bandwidth product of 2.5MHz are achieved with only 1mA of supply current per op amp.

Overload recovery times from positive and negative saturation conditions are 1.5ms and 3ms respectively, about a 100 or more times improvement over chopper amplifiers using external capacitors.

The LTC1051 is available in standard plastic and ceramic dual in line packages as well as a 16-pin SOL package. The LTC1053 is available in a standard 14-pin plastic package and an 18-pin SOIC. The LTC1051/LTC1053 is a plug in replacement for most standard dual/quad op amps with improved performance.

TYPICAL APPLICATION

High Performance Low Cost Instrumentation Amplifier

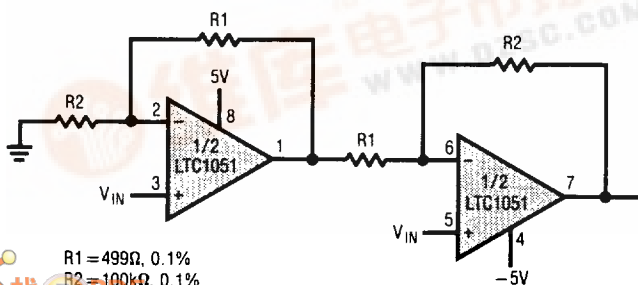

R1 = 499 Ω , 0.1%
 R2 = 100k Ω , 0.1%
 GAIN = 201
 MEASURED CMRR ~ 120dB AT DC
 MEASURED INPUT V_{OS} 3 μ V
 MEASURED INPUT NOISE 2 μ V_{p-p} (DC - 10Hz)

LTC1051 Noise Spectrum

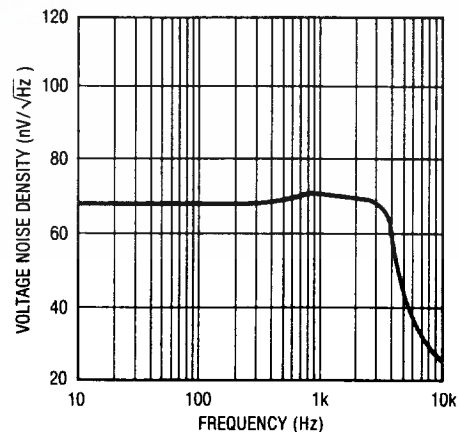

ABSOLUTE MAXIMUM RATINGS

Total Supply Voltage (V_+ to V_-) 16.5V
 Input Voltage ($V_+ + 0.3V$) to ($V_- - 0.3V$)
 Output Short Circuit Duration Indefinite

Operating Temperature Range
 LTC1051M, LTC1051AM -55°C to 125°C
 LTC1051C/LTC1053C, LTC1051AC -40°C to 85°C
 Storage Temperature Range -65°C to 150°C
 Lead Temperature (Soldering, 10 sec.) 300°C

PACKAGE/ORDER INFORMATION

TOP VIEW	ORDER PART NUMBER	TOP VIEW	ORDER PART NUMBER
<p>J PACKAGE 8-LEAD CERAMIC DIP</p> <p>N PACKAGE 8-LEAD PLASTIC DIP</p>	LTC1051MJ8 LTC1051CJ8 LTC1051CN8 LTC1051AMJ8 LTC1051ACJ8 LTC1051ACN8	<p>N PACKAGE 14-LEAD PLASTIC DIP</p>	LTC1053CN
<p>S PACKAGE 16-LEAD PLASTIC SOL</p>	LTC1051CS LTC1051ACS	<p>S PACKAGE 18-LEAD PLASTIC SOL</p>	LTC1053CS

2

ELECTRICAL CHARACTERISTICS $V_S = \pm 5V$, $T_A =$ operating temperature range unless otherwise specified.

PARAMETER	CONDITIONS	LTC1051/LTC1053			LTC1051A			UNITS
		MIN	TYP	MAX	MIN	TYP	MAX	
Input Offset Voltage	$T_A = 25^\circ\text{C}$		± 0.5	± 5	± 0.5	± 5		μV
Average Input Offset Drift		●	± 0.0	± 0.05	± 0.0	± 0.05		$\mu\text{V}/^\circ\text{C}$
Long Term Offset Drift			50		50			$\text{nV}/\sqrt{\text{Mo}}$
Input Bias Current	$T_A = 25^\circ\text{C}$		± 15	± 65	± 15	± 50		pA
LTC1051C/LTC1053C		●		± 135		± 100		pA
LTC1051M		●		± 450		± 300		pA
Input Offset Current (All Grades)	$T_A = 25^\circ\text{C}$		± 30	± 125	± 30	± 100		pA
		●		± 175		± 150		pA
Input Noise Voltage (Note 1)	$R_S = 100\Omega$, DC to 10Hz $R_S = 100\Omega$, DC to 1Hz		1.5 0.4		1.5 0.4	2		$\mu\text{V}_{\text{p-p}}$ $\mu\text{V}_{\text{p-p}}$
Input Noise Current	$f = 10\text{Hz}$		2.2		2.2			$\text{fA}/\sqrt{\text{Hz}}$
Common Mode Rejection Ratio, CMRR	$V_{\text{CM}} = V_-$ to $+2.7V$, $T_A = 25^\circ\text{C}$	●	106 100	130	114 110	130		dB dB
Differential CMRR	$V_{\text{CM}} = V_-$ to $+2.7V$, $T_A = 25^\circ\text{C}$		112		112			dB
LTC1051, LTC1053 (Note 2)								
Power Supply Rejection Ratio	$V_S = \pm 2.375V$ to $\pm 8V$	●	116	140	120	140		dB
Large Signal Voltage Gain	$R_L = 10\text{k}\Omega$, $V_{\text{OUT}} = \pm 4V$	●	116	160	120	160		dB
Maximum Output Voltage Swing	$R_L = 10\text{k}\Omega$ $R_L = 100\text{k}\Omega$	●	± 4.5 ± 4.5	± 4.85 ± 4.95	± 4.7	± 4.85 ± 4.95		V V
Slew Rate	$R_L = 10\text{k}\Omega$, $C_L = 50\text{pF}$		4		4			$\text{V}/\mu\text{s}$

LTC1051/LTC1053

ELECTRICAL CHARACTERISTICS $V_S = \pm 5V$, $T_A =$ operating temperature range unless otherwise specified.

PARAMETER	CONDITIONS	LTC1051A/LTC1051/LTC1053			UNITS
		MIN	TYP	MAX	
Gain Bandwidth Product			2.5		MHz
Supply Current/Op Amp	No Load, $T_A = 25^\circ\text{C}$		1	2 2.5	mA mA
Internal Sampling Frequency			3		kHz

$V_S = 5V$, GND, $T_A =$ operating temperature range unless otherwise specified.

PARAMETER	CONDITIONS	LTC1051A/LTC1051/LTC1053			UNITS
		MIN	TYP	MAX	
Input Offset Voltage	$T_A = 25^\circ\text{C}$		± 0.5	± 5	μV
Input Offset Drift			± 0.01	± 0.05	$\mu\text{V}/^\circ\text{C}$
Input Bias Current	$T_A = 25^\circ\text{C}$		± 10	± 50	pA
Input Offset Current	$T_A = 25^\circ\text{C}$		± 20	± 80	pA
Input Noise Voltage	DC to 10Hz		1.8		$\mu\text{V}_{\text{P-P}}$
Supply Current/Op Amp	No Load, $T_A = 25^\circ\text{C}$			1.5	mA

The ● denotes the specifications which apply over the full operating temperature range.

Note 2: Differential CMRR for the LTC1053 is measured between amplifiers A and D, and amplifiers B and C.

Note 1: For guaranteed noise specification contact LTC marketing.

TEST CIRCUITS

Electrical Characteristics Test Circuit

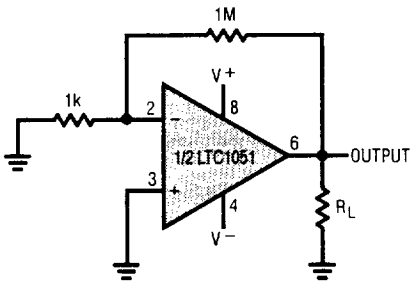

DC-10Hz Noise Test Circuit

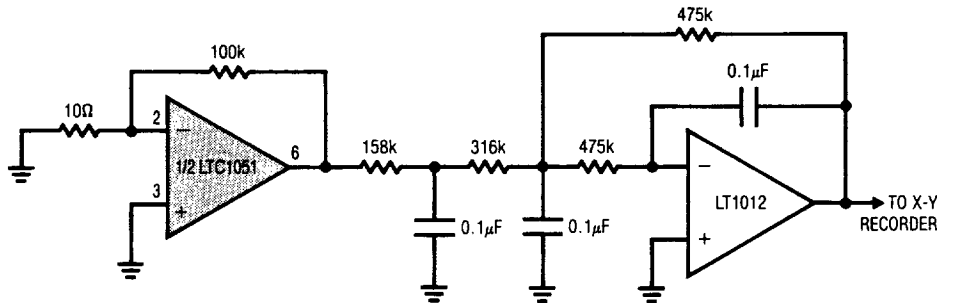

FOR 1Hz NOISE BW INCREASE ALL THE CAPACITORS BY A FACTOR OF 10.

TYPICAL PERFORMANCE CHARACTERISTICS

Common Mode Input Range vs Supply Voltage

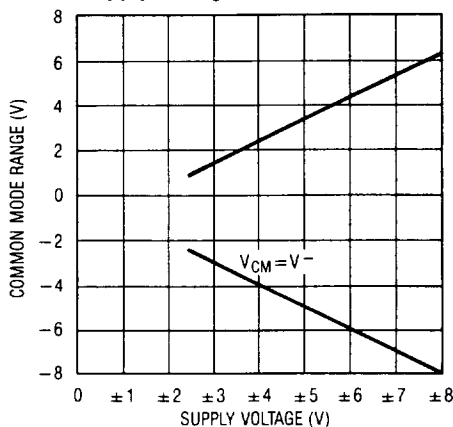

Sampling Frequency vs Supply Voltage

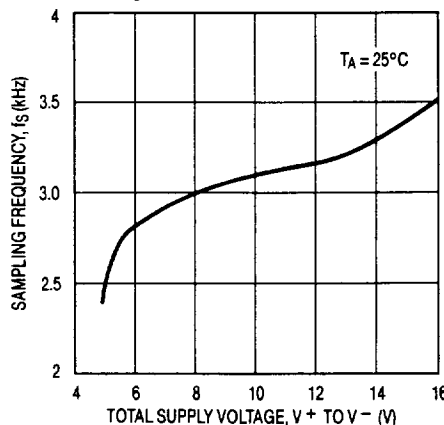

Sampling Frequency vs Temperature

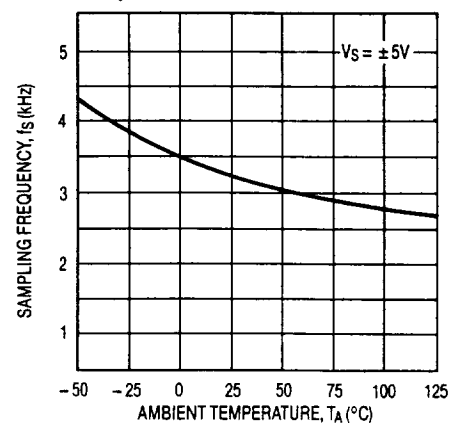

TYPICAL PERFORMANCE CHARACTERISTICS

Supply Current vs Supply Voltage Per Op Amp

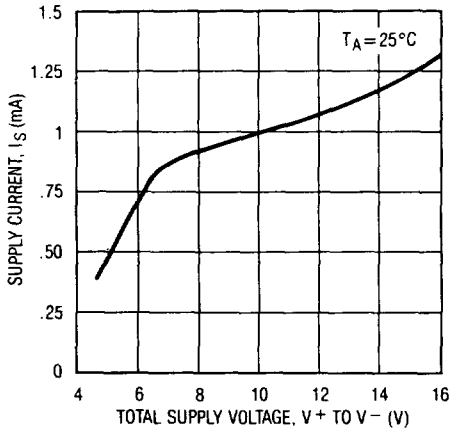

Supply Current vs Temperature Per Op Amp

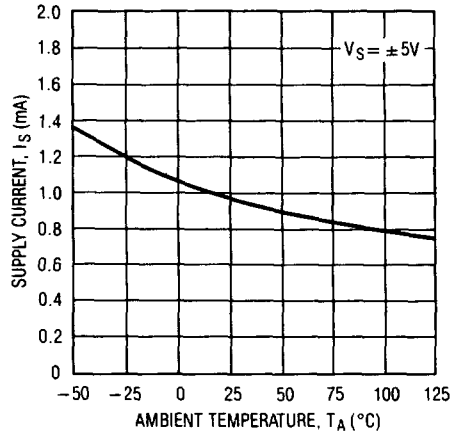

Gain/Phase vs Frequency

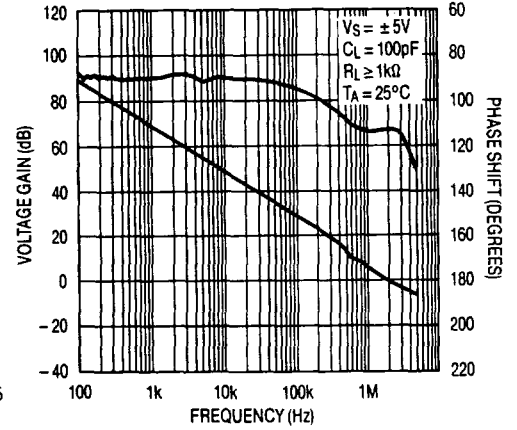

Output Short Circuit Current vs Supply Voltage

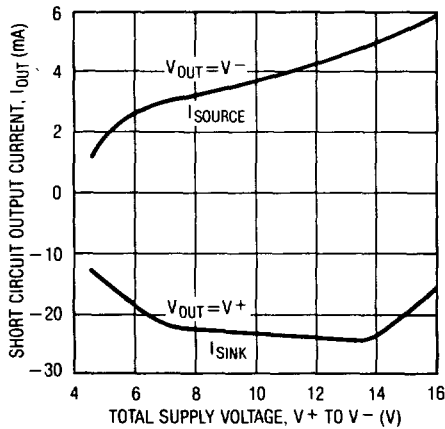

CMRR vs Frequency

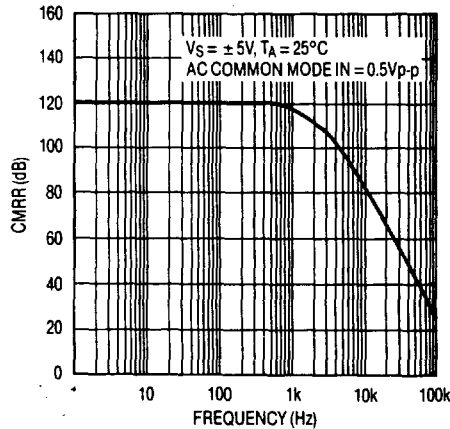

Gain/Phase vs Frequency

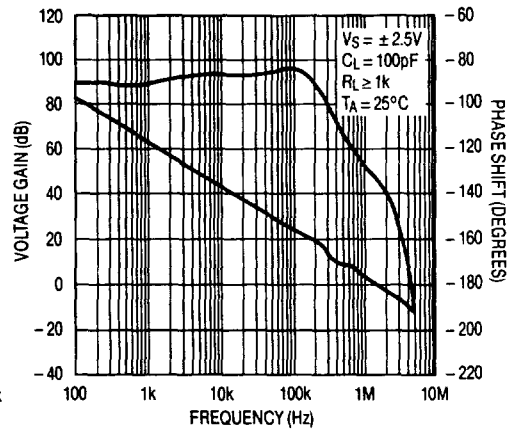

Overload Recovery

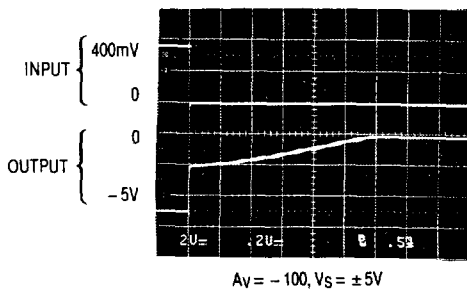

$A_v = -100, V_S = \pm 5V$

Small Signal Transient Response

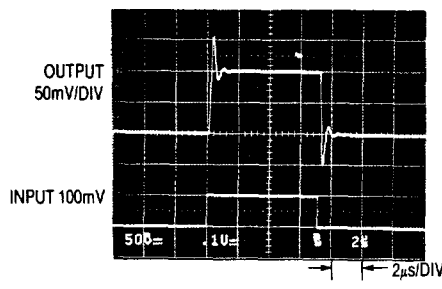

$A_v = +1, R_L = 10k, C_L = 100pF$
 $V_S = \pm 5V, T_A = 25^\circ C$

Large Signal Transient Response

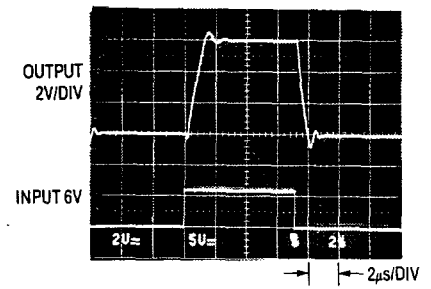

$A_v = +1, R_L = 10k, C_L = 100pF$
 $V_S = \pm 5V, T_A = 25^\circ C$

LTC1051/LTC1053

TYPICAL PERFORMANCE CHARACTERISTICS

LTC1051/LTC1053 DC to 10Hz Noise

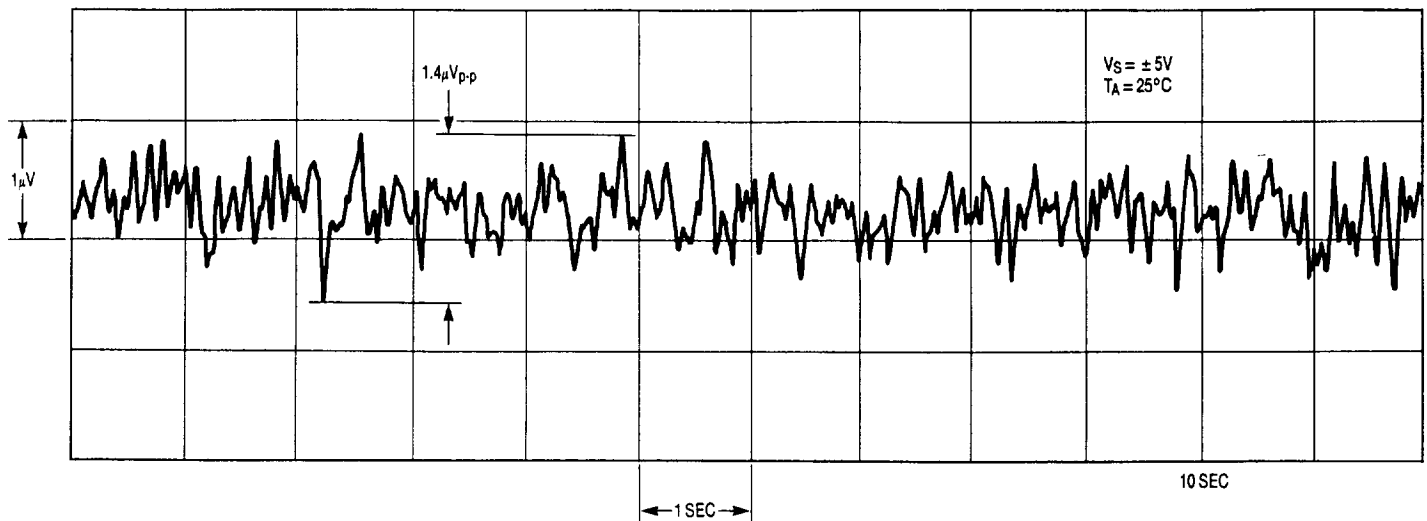

APPLICATIONS INFORMATION

ACHIEVING PICOAMPERE/MICROVOLT PERFORMANCE

Picoamperes

In order to realize the picoampere level of accuracy of the LTC1051/LTC1053, proper care must be exercised. Leakage currents in circuitry external to the amplifier can significantly degrade performance. High quality insulation should be used (e.g., Teflon, Kel-F); cleaning of all insulating surfaces to remove fluxes and other residues will probably be necessary — particularly for high temperature performance. Surface coating may be necessary to provide a moisture barrier in high humidity environments.

Board leakage can be minimized by encircling the input connections with a guard ring operated at a potential close to that of the inputs: in inverting configurations the guard ring should be tied to ground; in non-inverting connections to the inverting input. Guarding both sides of the printed circuit board is required. Bulk leakage reduction depends on the guard ring width.

Microvolts

Thermocouple effects must be considered if the LTC1051/LTC1053's ultra low drift op amps are to be fully utilized.

Any connection of dissimilar metals forms a thermoelectric junction producing an electric potential which varies with temperature (Seebeck effect). As temperature sensors, thermocouples exploit this phenomenon to produce useful information. In low drift amplifier circuits the effect is a primary source of error.

Connectors, switches, relay contacts, sockets, resistors, solder, and even copper wire are all candidates for thermal EMF generation. Junctions of copper wire from different manufacturers can generate thermal EMFs of $200\text{nV}/^\circ\text{C}$ — 4 times the maximum drift specification of the LTC1051/LTC1053. The copper/kovar junction, formed when wire or printed circuit traces contact a package lead, has a thermal EMF of approximately $35\mu\text{V}/^\circ\text{C}$ — 700 times the maximum drift specification of the LTC1051/LTC1053.

Minimizing thermal EMF-induced errors is possible if judicious attention is given to circuit board layout and component selection. It is good practice to minimize the number of junctions in the amplifier's input signal path. Avoid connectors, sockets, switches and relays where possible. In instances where this is not possible, attempt

APPLICATIONS INFORMATION

to balance the number and type of junctions so that differential cancellation occurs. Doing this may involve deliberately introducing junctions to offset unavoidable junctions.

When connectors, switches, relays and/or sockets are necessary they should be selected for low thermal EMF activity. The same techniques of thermally balancing and coupling the matching junctions are effective in reducing the thermal EMF errors of these components.

Resistors are another source of thermal EMF errors. Table 1 shows the thermal EMF generated for different resistors. The temperature gradient across the resistor is important, not the ambient temperature. There are two junctions formed at each end of the resistor and if these junctions are at the same temperature, their thermal EMFs will cancel each other. The thermal EMF numbers are approximate and vary with resistor value. High values give higher thermal EMF.

Table 1. Resistor Thermal EMF

Resistor Type	Thermal EMF/°C Gradient
Tin Oxide	~ mV/°C
Carbon Composition	~ 450 μ V/°C
Metal Film	~ 20 μ V/°C
Wire Wound	
Evenohm	~ 2 μ V/°C
Manganin	~ 2 μ V/°C

INPUT BIAS CURRENT, CLOCK FEEDTHROUGH

At ambient temperatures below 60°C, the input bias current of the LTC1051/LTC1053 op amps is dominated by the small amount of charge injection occurring during the

sampling and holding of the op amps input offset voltage. The average value of the resulting current pulses is 10pA to 15pA with sign convention shown in Figure 1.

As the ambient temperature rises, the leakage current of the input protection devices increases, while the charge injection component of the bias current, for all practical purposes, stays constant. At elevated temperatures (above 85°C) the leakage current dominates and the bias current of both inputs assumes the same sign.

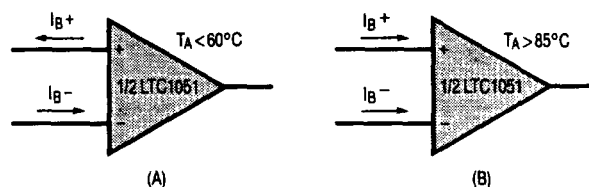

Figure 1. LTC1051 Bias Current

The charge injection at the op amp input pins will cause small output spikes. This phenomenon is often referred to as "clock feedthrough" and it can be easily observed when the closed loop gain exceeds 10V/V, Figure 2. The magnitude of the clock feedthrough is temperature independent but it increases when the closed loop gain goes up, when the source resistance increases, and when the gain setting resistors increase, Figure 2A, 2B. It is important to note that the output small spikes are centered at 0V level and they do not add to the output offset error budget. For instance, with $R_S = 1M\Omega$, the typical output offset voltage of Figure 2C is $V_{OS(OUT)} \approx 10^8 \times I_B^+ + 101V_{OS(in)}$. A 10pA bias current will yield an output of $1mV \pm 100\mu V$. The output clock feedthrough can be attenuated by lowering the value of the gain setting resistors, i.e. $R_2 = 10k$, $R_1 = 100\Omega$, instead of (100k, 1k; Figure 2).

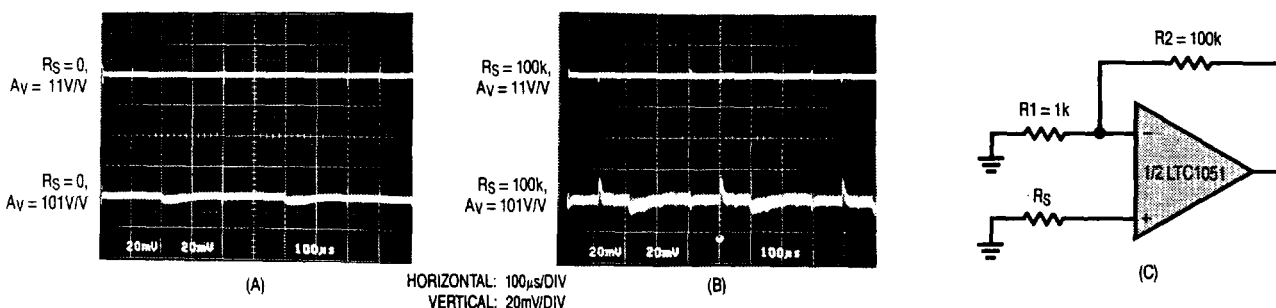

Figure 2. Clock Feedthrough

LTC1051/LTC1053

APPLICATIONS INFORMATION

Clock feedthrough can also be attenuated by adding a capacitor across the feedback resistor to limit the circuit bandwidth below the internal sampling frequency, Figure 3.

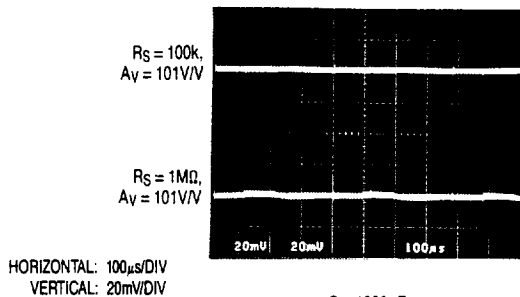

Figure 3. Adding a Feedback Capacitor to Eliminate Clock Feedthrough

INPUT CAPACITANCE

The input capacitance of the LTC1051/LTC1053 op amps is approximately 12pF. When the LTC1051/LTC1053 op amps are used with feedback factors approaching unity, the feedback resistor value should not exceed 7kΩ for industrial temperature range and 5kΩ for military temperature range. If a higher feedback resistor value is required, a feedback capacitor of 20pF should be placed across the feedback resistor. Note that the most common circuits with feedback factors approaching unity are unity gain followers and instrumentation amplifier front ends, Figure 4.

LTC1051/LTC1053 AS AC AMPLIFIERS

Although initially chopper stabilized op amps were designed to minimize DC offsets and offset drifts, the LTC1051/LTC1053 family, on top of its outstanding DC characteristics, presents efficient AC performance. For instance, at single +5V supply, each op amp typically con-

sumes 0.5mA and still provides 1.8MHz gain bandwidth product and 3V/μs slew rate. This, combined with almost distortionless swing to the supply rails, Figure 8, makes the LTC1051/LTC1053 op amps nearly general purpose. To further expand this idea, the “aliasing” phenomenon, which could occur under AC conditions, should be described and properly evaluated.

ALIASING

The LTC1051/LTC1053 are equipped with internal circuitry to minimize aliasing. Aliasing, no matter how small, occurs when the input signal approaches and exceeds the internal clock frequency. Aliasing is caused by the sampled data nature of the chopper op amps. A generalized study of this phenomenon is beyond the scope of a data-sheet, however, a set of rules of thumb can answer many questions.

1. Alias signals can be generally defined as output AC signals at a frequency of $nf_{CLK} \pm mf_{IN}$. The nf_{CLK} term is the internal sampling frequency of the chopper stabilized op amps, and its harmonics, mf_{IN} is the frequency of the input signal and its harmonics, if any.
2. If we arbitrarily accept that “aliasing” occurs when output alias signals reach an amplitude of 0.01% or more of the output signal, then: The approximate minimum frequency of an AC input signal which will cause aliasing is equal to the internal clock frequency multiplied by the square root of the op amp feedback factor. For instance, with closed loop gain of -10 , the feedback factor is $1/11$, and if $f_{CLK} = 2.6\text{kHz}$, alias signals can be detected when the frequency of the input signal exceeds 750Hz to 800Hz, Figure 5A.

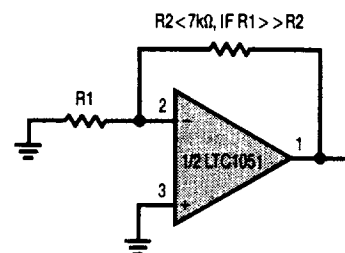

Figure 4. Operating the LTC1051 with Feedback Factors Approaching Unity

APPLICATIONS INFORMATION

- The number of alias signals increases when the input signal frequency increases, Figure 5B.
 - When the frequency, f_{IN} , of the input signal is less than f_{CLOCK} , the alias signal(s) amplitude(s) directly scale with the amplitude of the incoming signal. The output "signal to alias ratio" cannot be increased by just boosting the input signal amplitude. However, when the input AC signal frequency well exceeds the clock frequency, the amplitude of the alias signals does not directly scale with the input amplitude. The "signal to alias ratio" increases when the output swings closely to the rails, Figures 5B, 7. It is important to note that the LTC1051/LTC1053 op amps under light loads ($R_L \geq 10k\Omega$) swing closely to the supply rails without generating harmonic distortion, Figure 8.
 - For unity gain inverting configuration, all the alias frequencies are 80dB to 84dB down from the output signal, Figures 6A, 6B. Combined with excellent THD under wide swing, the LTC1051/LTC1053 op amps make efficient unity gain inverters.
- For gain higher than -1 , the "signal to alias" ratio decreases at an approximate rate of $-6dB$ per decade of closed loop gain Figure 8.

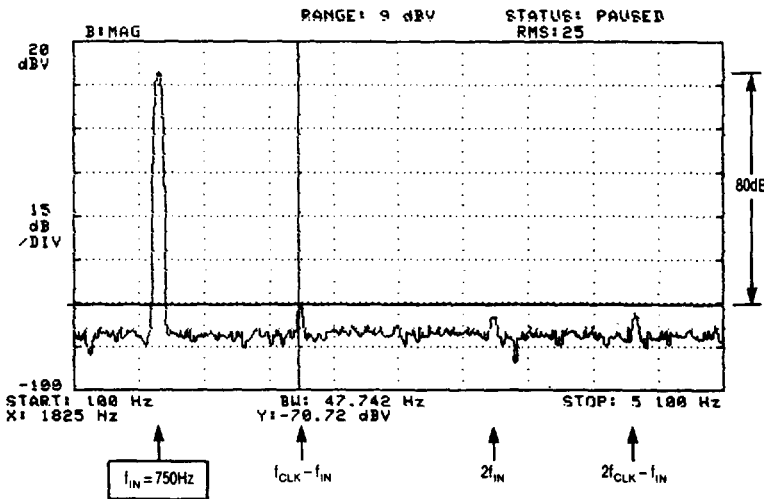

Figure 5A. Output Voltage Spectrum of 1/2 LTC1051 Operating as an Inverting Amplifier with Gain of 10, and Amplifying a 750Hz, 800mV Input AC Signal.

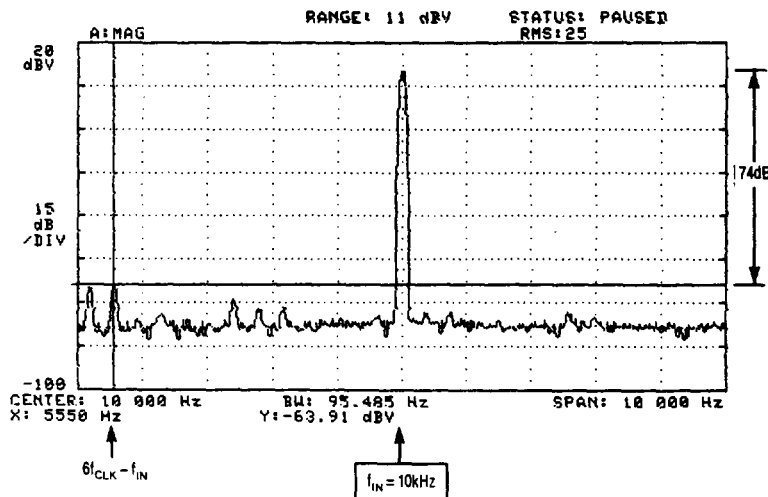
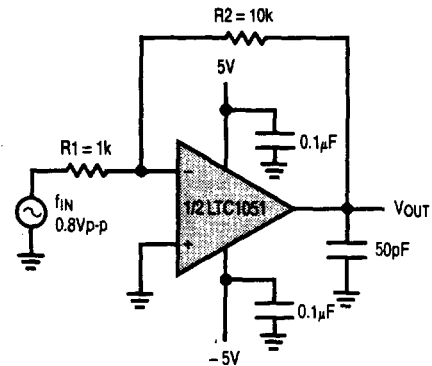

Figure 5B. Same as Figure 5A, but the AC Input Signal is 900mV, 10kHz



APPLICATIONS INFORMATION

- For closed loop gains of -10 or higher, the “signal to alias” ratio degrades when the value of the feedback gain setting resistor increases beyond $50k\Omega$. For instance, the $68dB$ value of Figure 7, decreases to $56dB$ if a ($1k\Omega$, $100k\Omega$) resistor set will be used to set the gain of -100 .
- When the LTC1051/LTC1053 are used as non-inverting amplifiers all the previous approximate rules of thumb

apply with the following exceptions: When the closed loop gain is $+10(V/V)$ and below, the “signal to alias” ratio is $1dB$ to $3dB$ less than the inverting case. When the closed loop gain is $100(V/V)$ the degradation can be up to $9dB$, especially when the input signal is much higher than the clock frequency (i.e. $f_{IN} = 10kHz$).

- The signal/alias ratio performance improves when the op amp has bandlimited loop gain.

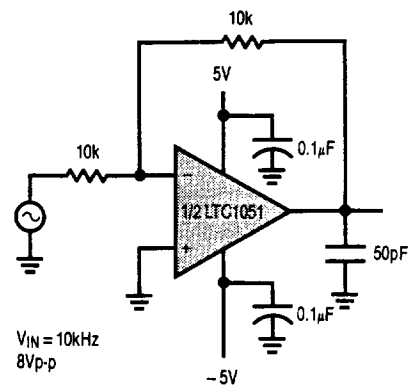
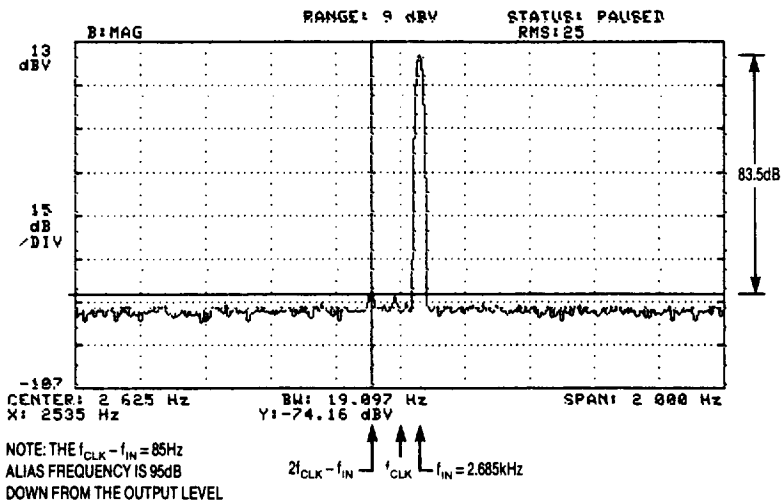

Figure 6A. Output Voltage Spectrum of 1/2 LTC1051 Operating as a Unity Gain Inverting Amplifier.
 $V_S = \pm 5V$, $R_L = 10k$, $C_L = 50pF$, $V_{IN} = 8Vp-p$, $2.685kHz$.

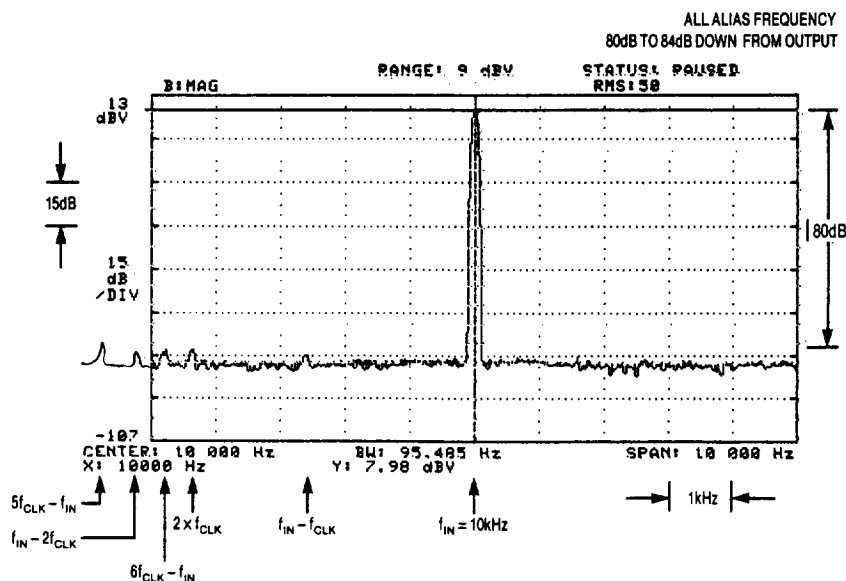

Figure 6B. Output Voltage Spectrum of 1/2 LTC1051, Operating as a Unity Gain Inverting Amplifier.
 $V_S = \pm 5V$, $R_L = 10k$, $C_L = 50pF$, $V_{IN} = 8Vp-p$, $10kHz$.

APPLICATIONS INFORMATION

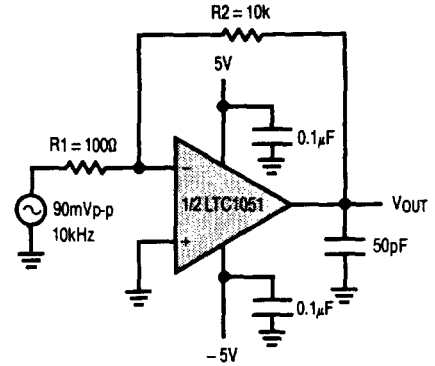
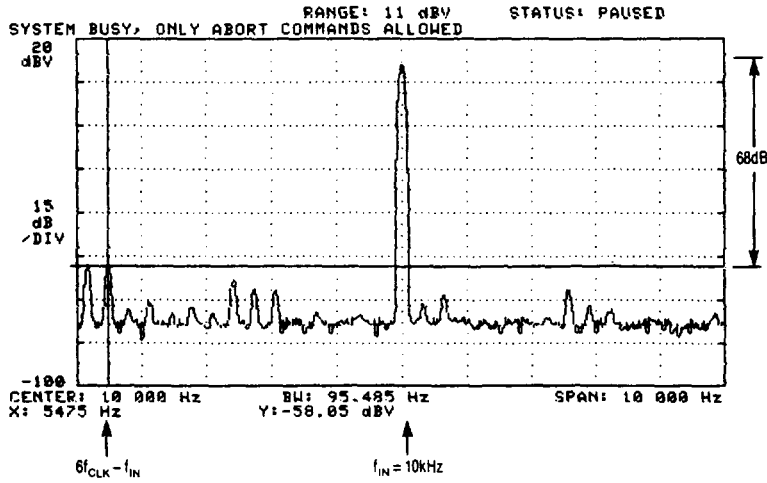

Figure 7. Output Voltage Spectrum of 1/2 LTC1051 Operating as an Inverting Amplifier with a Gain of -100 and Amplifying a 90mVp-p , 10kHz Input Signal. With a 9Vp-p Output Swing the Measured 2nd Harmonic (20kHz) was 75 Down from the 10kHz Input Signal.

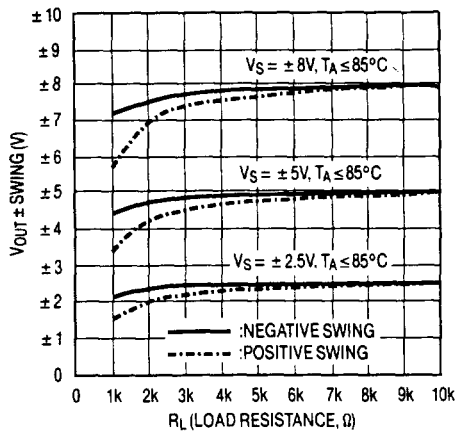

Figure 8. Output Voltage Swing vs Load

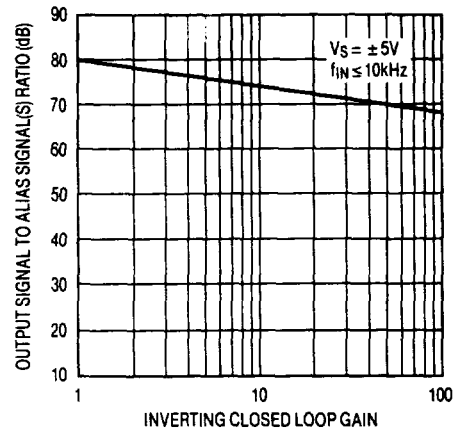
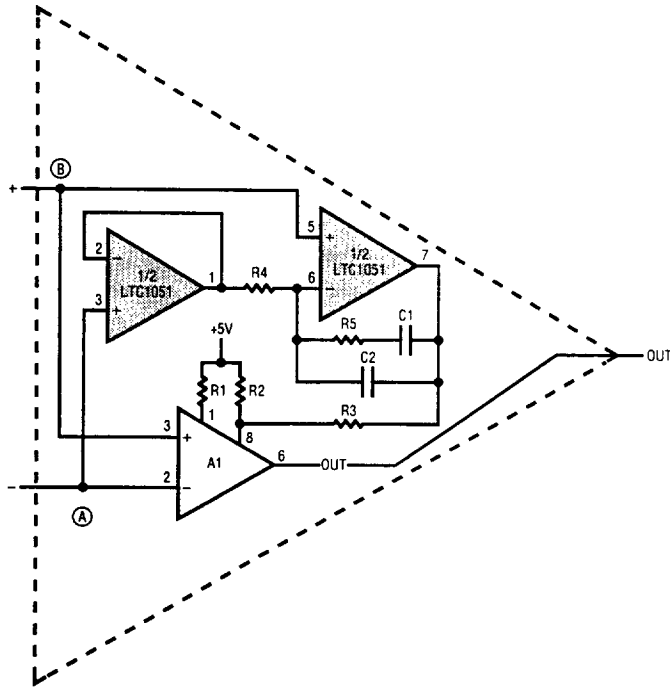

Figure 9. Signal to Alias Ratio vs Closed Loop Gain

LTC1051/LTC1053

APPLICATION CIRCUITS

Obtaining Ultra-Low V_{OS} Drift and Low Noise



The dual chopper op amp buffers the inputs of A, and corrects its offset voltage and offset voltage drift. With the shown R,C values, the power up warm up time is typically 20s. The step response of the composite amplifier does not present settling tails. The LT1007 should be used when extremely low noise, V_{OS} and V_{OS} drift are sought when the input source resistance is low. (For instance a 350 Ω strain gauge bridge.) The LT1012 or equivalent should be used when low bias current (100pA) is also required in conjunction with DC to 10Hz low noise, and low V_{OS} and V_{OS} drift. The measured typical input offset voltages were less than 2 μ V.

A1	R1	R2	R3	R4	R5	C1	C2	$\bar{e}_{OUT}(DC-1Hz)^{**}$	$\bar{e}_{OUT}(DC-10Hz)^{**}$
LT1007	3k	2k	340k	10k	100k	0.01 μ F	0.001 μ F	0.1 μ Vp-p	0.15 μ Vp-p
LT1012*	750 Ω	57 Ω	250k	10k	100k	0.01 μ F	0.001 μ F	0.3 μ Vp-p	0.4 μ Vp-p

*Interchange connections (A) and (B).

**Noise measured in a 10 sec. window. Peak-to-peak noise was also measured for 10 continuous minutes: With the LT1007 op amp the recorded noise was 0.2 μ Vp-p for both DC-1Hz and DC-10Hz.

LTC1051/LT1007 Peak-to-Peak Noise

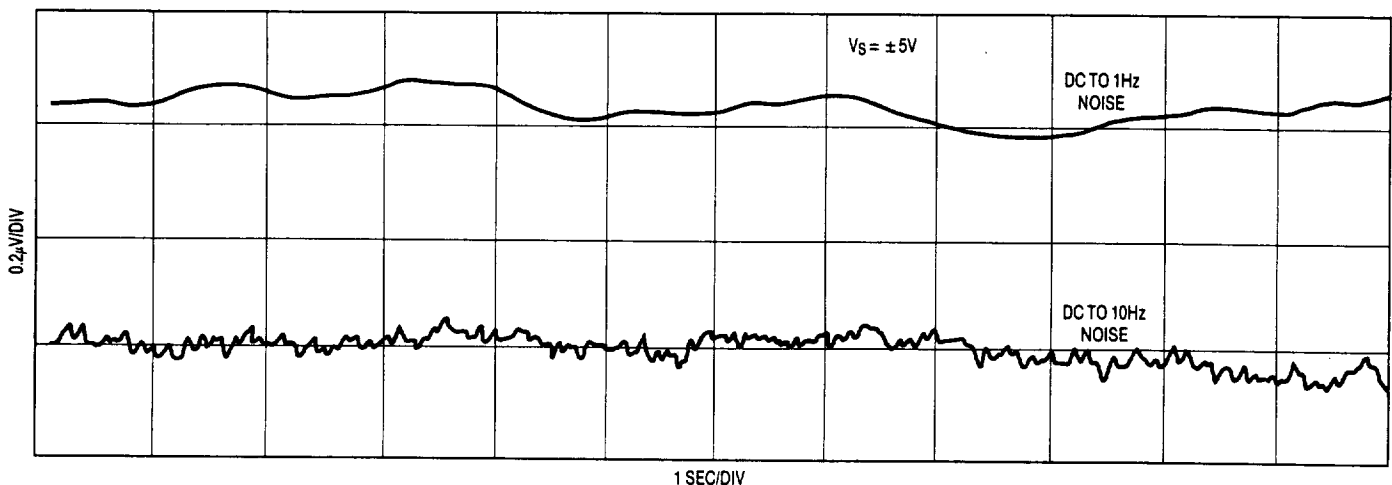

APPLICATION CIRCUITS

Paralleling Choppers to Improve Noise

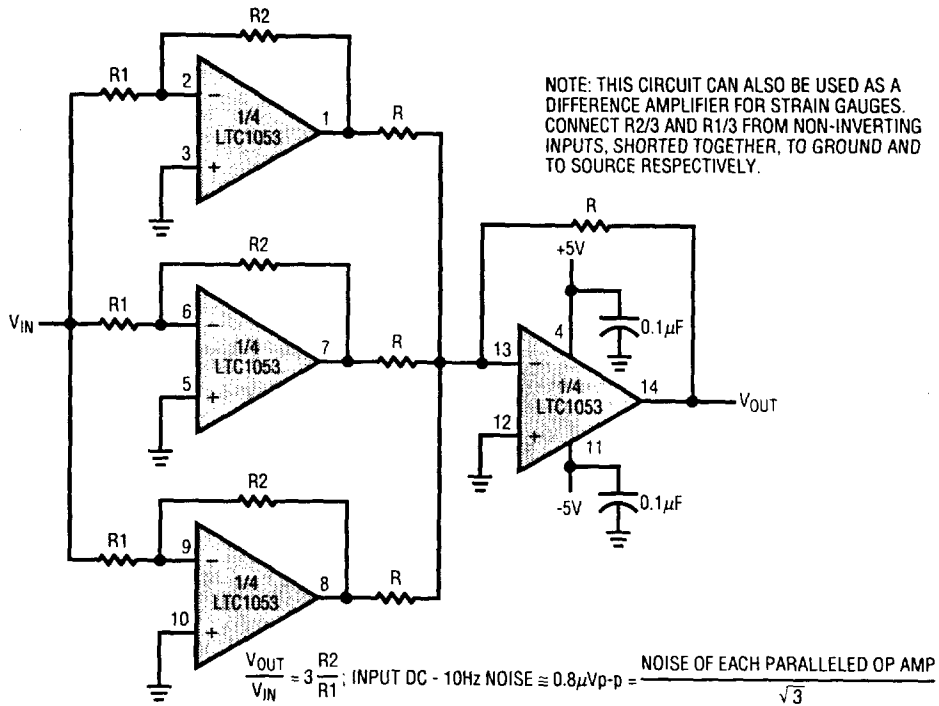

2

Differential Voltage to Current Converter

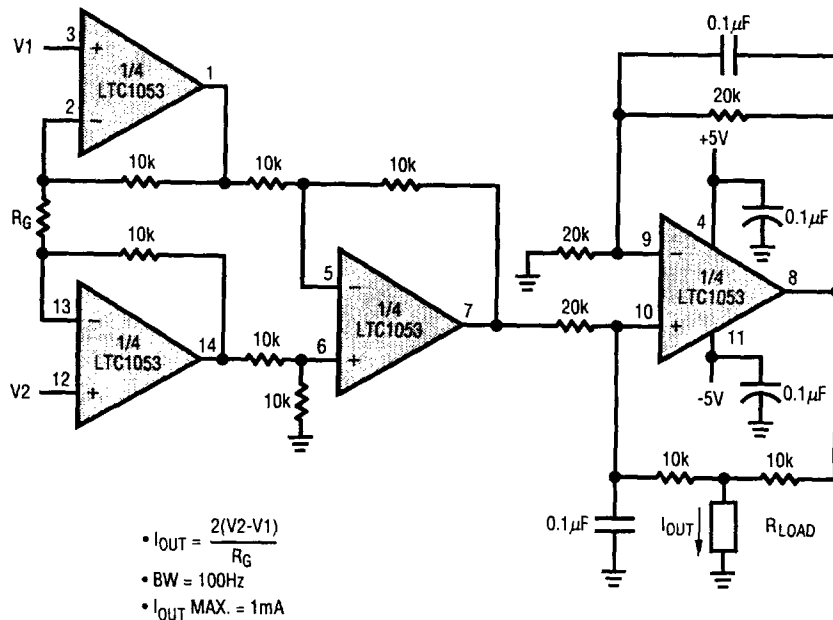

LTC1051/LTC1053

APPLICATION CIRCUITS

Multiplexed Differential Thermometer

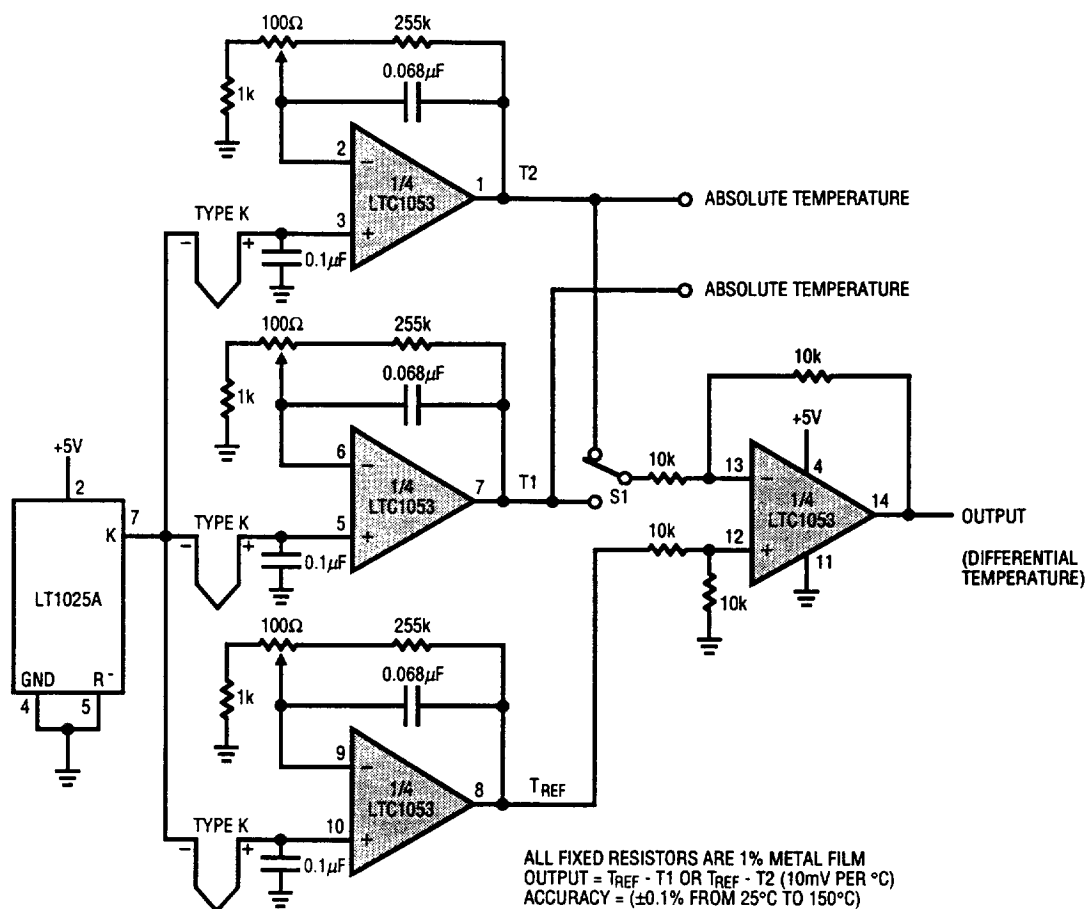

Six Decade Log Amplifier

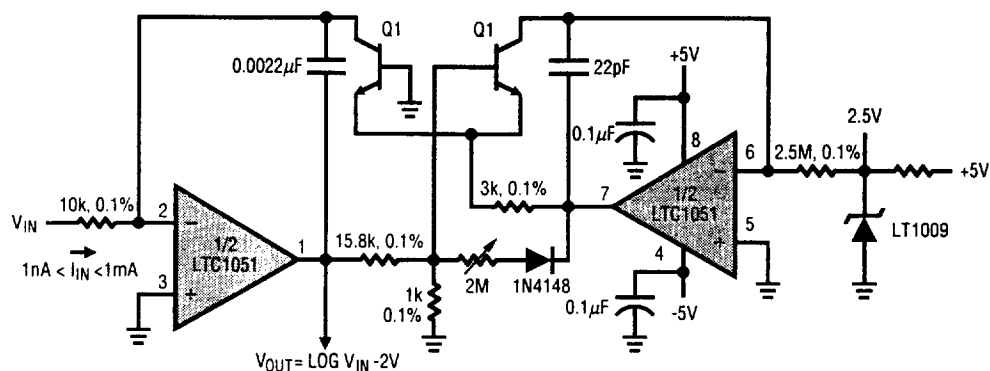

Q1: TEL LAB TYPE Q81
 ADJUST 2M POR. FOR NON-LINEARITIES

APPLICATION CIRCUITS

Dual Instrumentation Amplifier

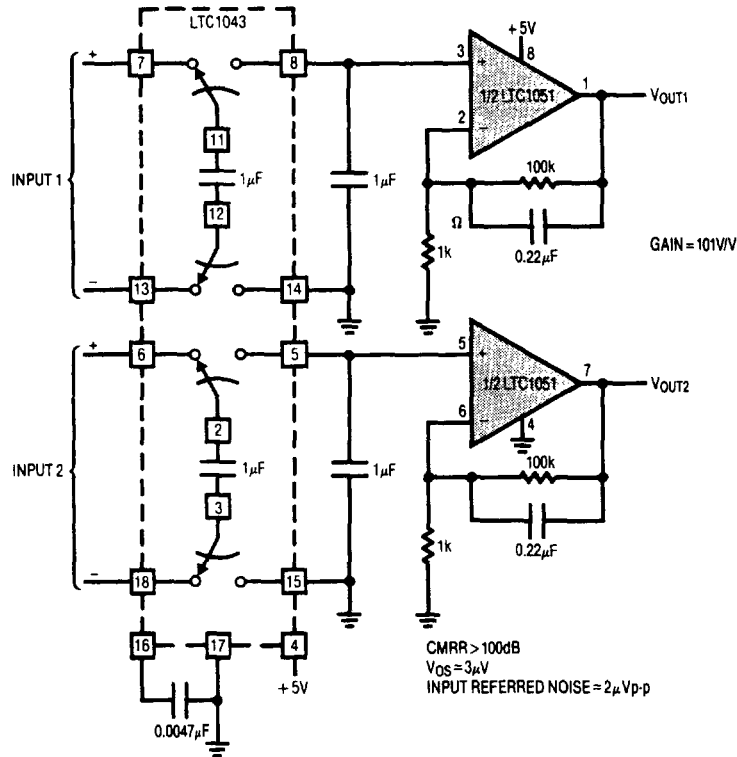

2

Linearized Platinum Signal Conditioner

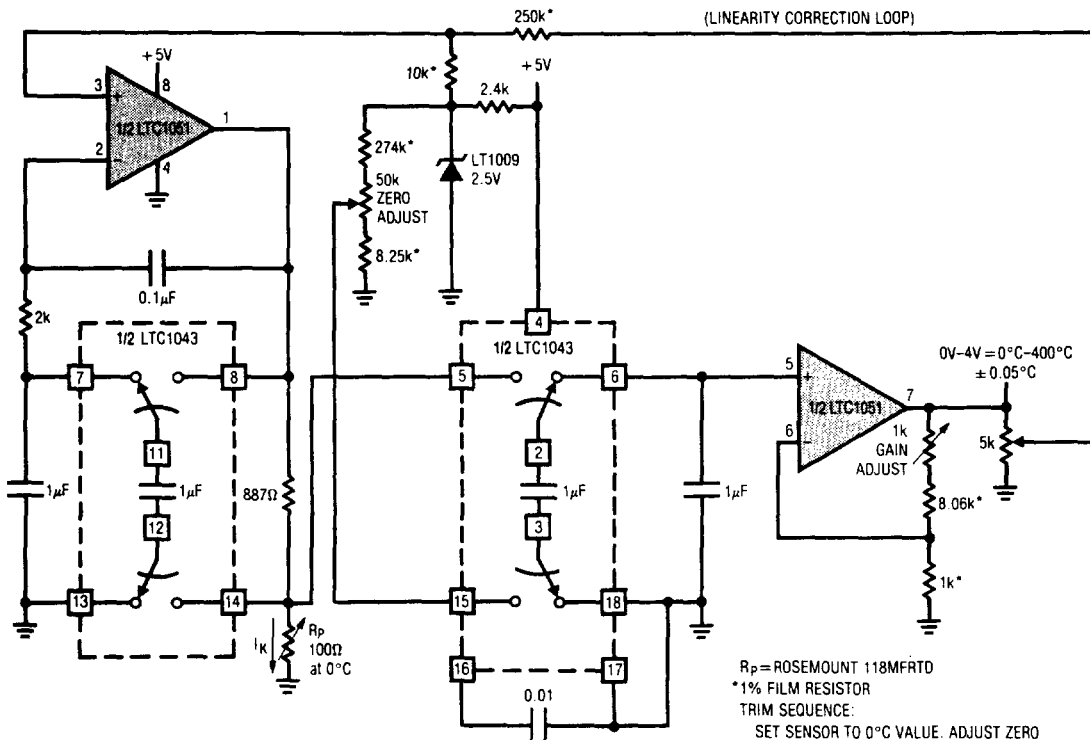

$R_P = ROSEMOUNT 118MFR1TD$
 $*1\% \text{ FILM RESISTOR}$
TRIM SEQUENCE:
 SET SENSOR TO $0^{\circ}C$ VALUE. ADJUST ZERO FOR $0V$ OUT. SET SENSOR TO $100^{\circ}C$ VALUE. ADJUST GAIN FOR $1.000V$ OUT. SET SENSOR TO $400^{\circ}C$ VALUE. ADJUST LINEARITY FOR $4.000V$ OUT. REPEAT AS REQUIRED. FOR MORE INFORMATION REFER TO AN3.

LTC1051/LTC1053

APPLICATION CIRCUITS

DC Accurate, 3rd Order, 100Hz, Butterworth Antialiasing Filter

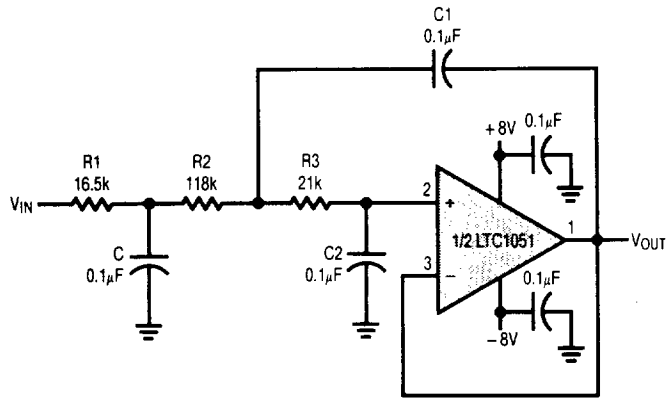

WIDEBAND NOISE $9\mu\text{VRMS}$
 THD + NOISE = 0.0012%, $1\text{VRMS} < V_{\text{IN}} < 2\text{VRMS}$, $V_{\text{S}} = \pm 8\text{V}$
 $V_{\text{OS}}(\text{OUT}) < 5\mu\text{V}$

Dynamic Range

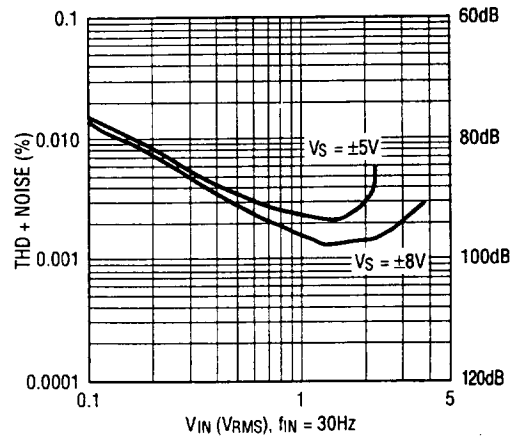

DC Accurate, 18-Bit 4th Order Antialiasing Bessel (Linear Phase), 100Hz, Lowpass Filter

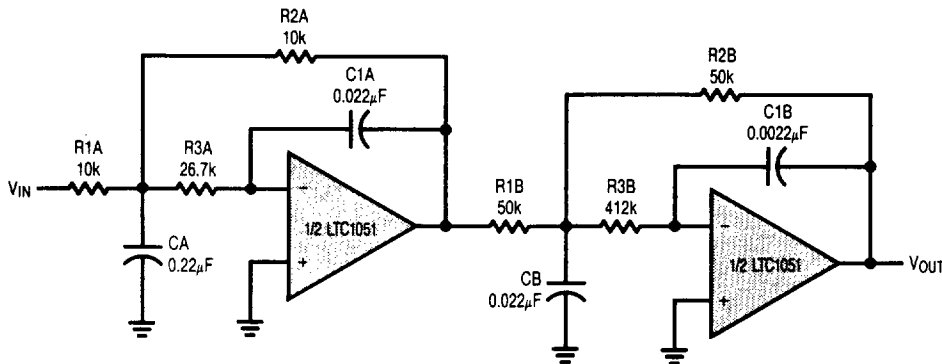

WIDEBAND RMS NOISE $4.5\mu\text{VRMS}$
 THD + NOISE = 0.0005% (= 106dB DYN. RANGE), $2\text{VRMS} \leq V_{\text{IN}} \leq 3\text{VRMS}$
 $V_{\text{OS}} \text{ OUT} < 10\mu\text{V}$

Dynamic Range

