

Ordering number : EN *5651

Bi-CMOS LSI



LV2700V

Spread Spectrum Communications IC

Preliminary

Overview

The LV2700V provides the reception and transmission functions necessary for half-duplex communication in spread-spectrum communications systems.

Features

- Frequency conversion is not required. (direct signal processing at 236 MHz)
- Wide spread-spectrum bandwidth (20 MHz)
- Sanyo developed system for PN code synchronization
- Allows direct primary modulation (FSK and FM) by data and analog signals. (Maximum data rate: 150 kbps)
- Low-voltage operation (2.7 to 5.5 V)
- Low power dissipation (36 mW in RX mode)

Functions

[TX Block]

- Spectrum spreader
- Crystal oscillator circuit
- PN code generator (M sequence)
- M sequence code length (31 or 63 chips) and tap switching
- 9.83 MHz PLL

- Band limiting filter (LPF) for data transmission [RX Block]
- Spectrum despreader
- Synchronization supplementation and protection
- 236-MHz PLL
- PN code generator (M sequence)
- M sequence code length (31 or 63 chips) and tap switching
- FSK (FM) demodulator
- Lock detector

Package Dimensions

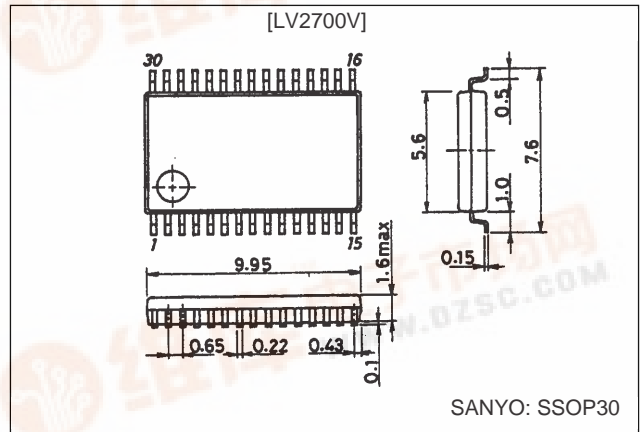

Specifications

Maximum Ratings at Ta = 25°C

Parameter	Symbol	Conditions	Ratings	Unit
Maximum supply voltage	V _{CC} max		6	V
Allowable power dissipation	P _d max		150	mW
Operating temperature	T _{opr}		-20 to +75	°C
Storage temperature	T _{stg}		-40 to +125	°C

Operating Conditions at Ta = 25°C

Parameter	Symbol	Conditions	Ratings	Unit
Recommended supply voltage	V _{CC}		3	V
Allowable voltage range	V _{CCOP}		2.7 to 5.5	V



LV2700V

Electrical Characteristics at $T_a = 25^\circ\text{C}$, $V_{CC} = 3\text{ V}$, $f_c = 236\text{ MHz}$, $f_m = 10\text{ kHz}$, $V_m = 0.2\text{ Vp-p}$

Parameter	Symbol	Conditions	Ratings			Unit
			min	typ	max	
Quiescent current	$I_{CCO\text{TX}}$	$\text{TX}V_{CC} + V_{DD}$		8	11	mA
	$I_{CCO\text{RX}}$	$\text{RF}V_{CC} + \text{RX}V_{CC} + V_{DD}$		12	16	mA
[TX Block]						
Modulated signal voltage	$V_{O\text{TX}}$	TXDATAOUT , $f = 10\text{ kHz}$		0.2		Vp-p
RF output voltage	$V_{O\text{TX}}$	TXREOUT		-35		dBm
Spread bandwidth	WS	TXRFOUT		19.7		MHz
[RX Block]						
Input sensitivity	$V_{S\text{RX}}$	RFIN			-75	dBm
Demodulated output 1	High level	$V_{O\text{RX1H}}$	RXOUT	2.5		V
	Low level	$V_{O\text{RX1L}}$	RXOUT		0.4	V
Demodulated output 1	$V_{O\text{RX2}}$	Pin 10 output w/o CEXT	240	300		mVrms
Total harmonic distortion	THD RX	Pin 10 output w/o CEXT		0.5	2	%
Signal-to-noise ratio	S/N	Pin 10 output w/o CEXT	45	55		dB
[CMOS-Level Interface]						
Input high-level voltage	V_{IH}	Pins 11 to 15, 17	2.1			V
Input low-level voltage	V_{IL}	Pins 11 to 15, 17			0.6	V
Output high-level voltage	V_{OH}	Pins 8, 9	2.5			V
Output low-level voltage	V_{OL}	Pins 8, 9			0.4	V
Input high-level current	I_{IH}	Pins 11 to 15, 17			5	μA
Input low-level current	I_{IL}	Pins 11 to 15, 17			5	μA
Input amplitude	V_{IN}	VCOIN	-16			dBm
Crystal oscillator frequency conditions	X_{OSC}	XIN, XOUT	5		13	MHz
Input capacitance	C_{IN}	RFIN, XIN, VCOIN		2.5		pF

LV2700V

Block Diagram

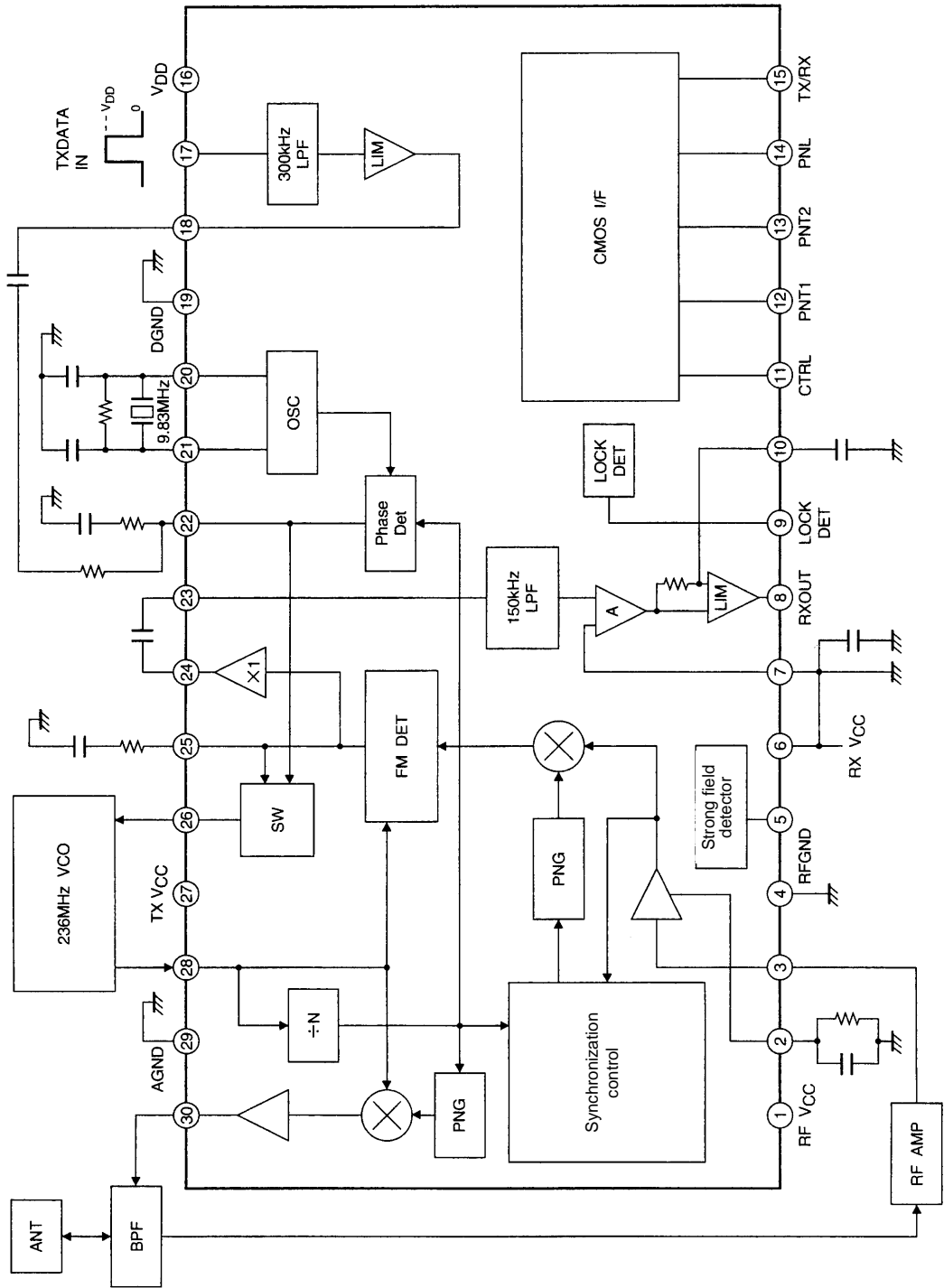

A06916

LV2700V



Pin Functions

Pin No.	Pin	Pin voltage(V)	Pin function	Equivalent circuit
1	RFVCC		RF block power supply	
2	REXT	0.2	Connection for the external capacitor and resistor used by the internal RF amplifier	
3	RFIN	1	RF input	
4	RFGND		RF block ground	
5	ANTDUMP	1.2	Output for the DC voltage used under strong reception conditions to prevent saturation of the RF amplifier. Voltage variability range: about 0.5 V	
6	RXVCC		Reception block power supply	
7	BIASIN		DC bias voltage for the demodulation signal processing block (LPF, amplifier, limiter)	
8	RXOUT		Demodulated data output (This is an open drain output.)	
9	LOCK DET		Outputs a high level when PN code synchronization is established. (This is a CMOS-level output.)	
10	CEXT	Same as V7	Amplifier output for demodulated output. The pin 8 output data is made valid by connecting a capacitor between this pin and ground.	

Continued on next page.

LV2700V

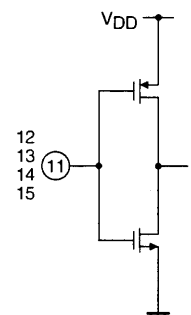
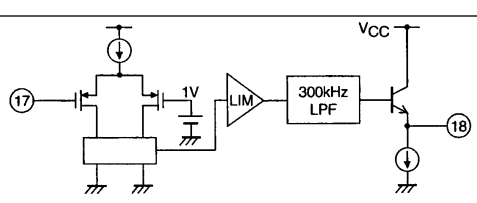
Continued from preceding page.

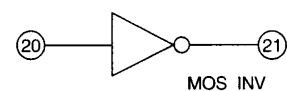
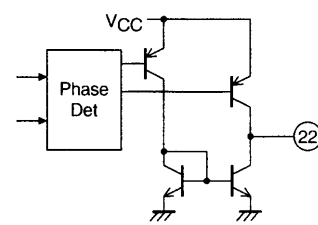
Pin No.	Pin	Pin voltage(V)	Pin function	Equivalent circuit															
11	CTRL		Turns the optimal PN code synchronization control on or off. Control is turned on by a high level input.	 <p style="text-align: right;">A06922</p>															
12	PNT1		Tap selection for the PN code (M sequence)																
13	PNT2		Tap selection for the PN code (M sequence). These pins select one of three code types. <table border="1" style="margin: 10px auto;"> <thead> <tr> <th>PNT1</th> <th>PNT2</th> <th>PN code</th> </tr> </thead> <tbody> <tr> <td>0</td> <td>0</td> <td>CODE1</td> </tr> <tr> <td>0</td> <td>1</td> <td>CODE2</td> </tr> <tr> <td>1</td> <td>0</td> <td>CODE3</td> </tr> <tr> <td>1</td> <td>1</td> <td style="text-align: center;">/</td> </tr> </tbody> </table> <p>0 = Low 1 = High</p>		PNT1	PNT2	PN code	0	0	CODE1	0	1	CODE2	1	0	CODE3	1	1	/
PNT1	PNT2	PN code																	
0	0	CODE1																	
0	1	CODE2																	
1	0	CODE3																	
1	1	/																	
14	PNL		PN code length selection High: 63 chips Low: 31 chips																
15	TX/RX		Send/receive mode selection. High: Transmission Low: Reception																
16	V _{DD}		CMOS block power supply																
17	TX DATAIN		Transmission data input (CMOS levels). Do not apply analog signals to this pin.	 <p style="text-align: right;">A06923</p>															
18	TX DATAOUT		Transmission data output. The output signal is band limited to 300 kHz and voltage limited to 1 V _{p-p} .																
19	DGND		CMOS block ground																
20	XIN	1/2V _{CC}	Input for the 9.8304 MHz reference oscillator inverter.																
21	XOUT	1/2V _{CC}	Output for the 9.8304 MHz reference oscillator inverter. Add a resistor of about 1 MΩ between XIN and XOUT.	 <p style="text-align: right;">A06924</p>															
22	TXLPF	1.5	Connection for the 9.8-MHz PLL loop filter used in transmission.	 <p style="text-align: right;">A06925</p>															

Continued on next page.

LV2700V

Continued from preceding page.

Pin No.	Pin	Pin voltage(V)	Pin function	Equivalent circuit
23	LPFIN	Same as V7	Demodulated signal input (loop filter output) used in reception.	<p style="text-align: right;">A06926</p>
24	RXPDOUT	Same as V25	Pin 25 buffer output. Connect an external low-pass filter between pins 23 and 24 if required.	<p style="text-align: right;">A06927</p>
25	RXLPF	1.5	Connection for the 236-MHz PLL loop filter used in reception.	<p style="text-align: right;">A06928</p>
26	LPFOUT	1.5	Control input for the 236-MHz VCO. The LV2700V includes a switch for selecting the loop filter depending on the mode (transmission or reception).	
27	TX V _{CC}		Transmission power supply	
28	VCOIN	1/2 V _{CC}	Input for the output from the 236-MHz VCO. Minimum input level: about -20 dBm	<p style="text-align: right;">A06929</p>
29	AGND		Analog system ground	
30	TX RFOUT	1.3	Spread-spectrum RF output (in transmission mode)	<p style="text-align: right;">A06930</p>

Circuit Operation and Usage Notes

1. RF amplifier block

The LV2700V includes an on-chip RF amplifier that provides a gain of about 15 dB. An input sensitivity of about -100 dBm can be acquired by adding an external 25-dB RF amplifier. Since IF frequency conversion is not used, a costly IF filter is not required. While the frequencies used are selected to be values relatively infrequently used in the weak field range (under 320 MHz), out of band components must be excluded using a bandpass filter after the antenna to improve both the interference rejection characteristics and the input sensitivity.

2. 236-MHz VCO

- The external 236-MHz VCO operates as follows in transmission and reception modes

[TX mode]

The VCO is adjusted to 236 MHz by a PLL circuit based on the 9.8304 reference.

That is, the phases of the VCO output that is input to pin 28 and the signal created by dividing the 9.8304 MHz reference oscillator output by 24 are compared and edge-type phase detector. The error signal is integrated by the pin 22 loop filter and fed back through pin 26 to the VCO control input.

[RX mode]

The spread spectrum RF signal input to pin 3 is amplified by 15 dB and a narrow band signal is recovered by a despreader circuit. The PLL circuit is then used for FM detection. That is, the phases of that signal and the VCO output from pin 28 are compared, and the error signal is integrated by the pin 25 loop filter and fed back through pin 26 to the VCO control input. An FM detected demodulated signal can be acquired from pin 25 at this time.

- Main characteristics

- For half-duplex communication, a VCO circuit using a SAW resonator is used for both transmission and reception.

Control sensitivity: 0.7 to 1.5 MHz/V

Frequency range: 236 MHz \pm 2 MHz

SAW resonator: We recommend the SAW resonators manufactured by Murata Mfg. Co., Ltd. (with a series resonance frequency error of \pm 500 ppm).

See the VCO circuit on page 8 for the recommended circuit, which is a Colpitts oscillator circuit.

- For unidirectional communication, an LC circuit based VCO may be used for the transmission side.

- The reception PLL circuit lock time is between 2 and 10 ms when power is first applied and between 0.5 and 1.0 ms after a transition from no input to the input present state.

3. FSK (FM) modulation technique

Modulation frequency range: 200 Hz to 150 kHz

When a modulated signal is applied to pin 22, there are limitations on low band FSK (FM) modulation, since this is equivalent to applying the modulation as a disturbance signal to the PLL circuit. If it is necessary to apply modulation to even lower bands, the 9.8 MHz reference oscillator circuit should be modified to be a VCXO circuit.

[For data input]

Apply the input data to pin 17. The signal is band limited to 300-kHz and then voltage limited to 1 V_{p-p} and output from pin 18. This signal is passed through a series RC circuit and connected to pin 22. The capacitor is a DC-cut capacitor of about 1 μ F. The resistor should be about 20 k Ω , and is used for modulation adjustment.

[For analog signal input]

Do not use the internal 300-kHz low-pass filter and limiting amplifier, but rather apply the signal through the RC circuit to pin 22 directly.

When the resistor is 20 k Ω , the optimal signal input level will be about 0.3 V_{p-p}.

4. Notes on the FSK (FM) demodulated signal

[For data output]

Connect a capacitor of about 0.1 μ F between pins 23 and 24, and another 1 μ F capacitor between pin 10 and ground. This will allow a CMOS-level data output signal to be acquired from pin 8.

[For analog output]

An analog signal can be acquired from pin 10. In this case, do not insert a capacitor between pin 10 and ground. The cutoff frequency of the internal 150-kHz low-pass filter is set somewhat high for two reasons: to prevent PN code leakage and to limit attenuation of high-speed data as much as possible. As a result, this filter is inadequate for

LV2700V

reducing upper harmonic, high band, and other noise in audio signals. The LV2700V is designed so that good quality audio signals can be acquired by connecting an external filter between pins 23 and 24. The pin 24 output includes a buffer amplifier, thus making it a low-impedance output so that this output does not influence the pin 25 loop filter.

5. Pin 7

The DC bias of the amplifier that is connected after the 150-kHz low-pass filter is set with an external resistor. Select a value for this resistor so that V7 will be 1.2 volts when V_{CC} is 3 volts.

6. Lock detection

The LOCK DET pin (a CMOS-level output) goes high when PN code synchronization is detected. This output can be used as a simple technique for determining whether or not a carrier is present.

7. The ANTDUMP pin (pin 5)

This pin outputs a DC level proportional to the RF input level. However, since this level is proportional to the input dBm value, it is not appropriate for use as an S-meter signal. It indicates voltage changes that are only meaningful in strong field reception conditions. It can be used to prevent saturation of the front end RF amplifier. However, the voltage change is +0.5 volt. (The pin 5 voltage for low input levels will be about 1.2 V.)

8. Power supply voltage application

[TX mode]

Provide the power-supply voltage to all the power-supply pins TXV_{CC} , RFV_{CC} , RXV_{CC} , and V_{DD} . Power saving is applied to the RF block bias internally.

[RX mode]

Provide the power-supply voltage to the RFV_{CC} , RXV_{CC} , and V_{DD} pin. TXV_{CC} must be left open.

9. When changing the RF frequency from 236 MHz

There are cases, for example due to considerations related to the SAW resonator characteristics, where it may be desirable to construct a system using a frequency other than 236 MHz. A 236-MHz AM synchronization detection output is used for PN code synchronization control. Since an RC circuit is used for the VCO output 90° phase shift circuit for this AM synchronization detection, it may not be possible to acquire the stipulated phase difference if the frequency is moved significantly far from 236 MHz. Assuming that a range of $45 \pm 5^\circ$ is allowed, the corresponding frequency range will be 200 to 280 MHz.

Characteristics

236-MHz VCO Control Characteristics

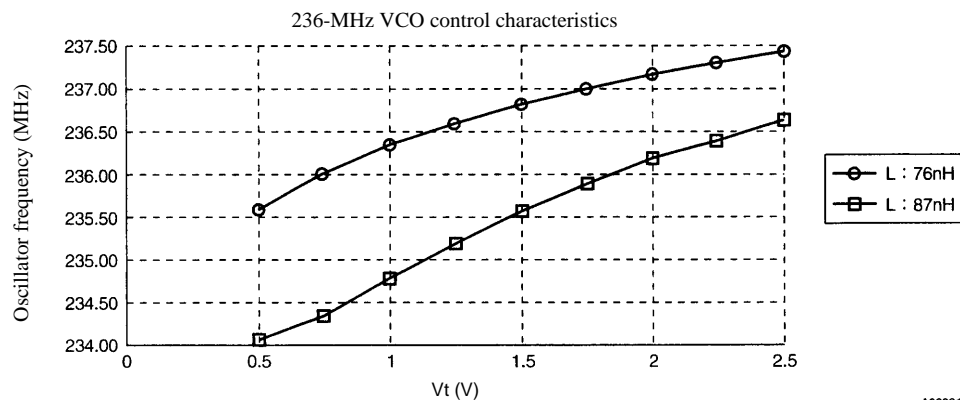

LV2700V

VCO Circuit

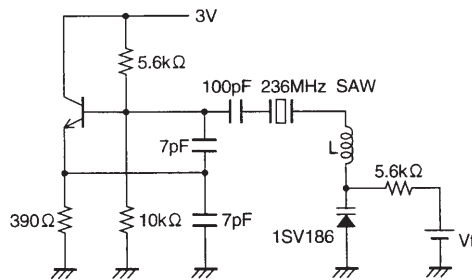

Transistor: 2SC5245

Use an inductor with a value of 84 nH \pm 2% for the series inductor L.

A06932

An LC oscillator circuit may be used for the transmission side VCO for unidirectional communications systems.

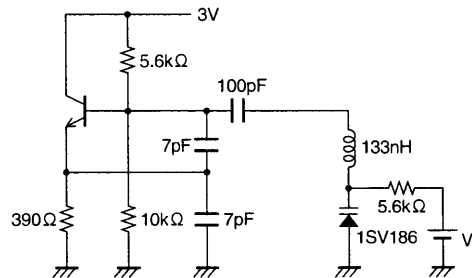

A06933

- No products described or contained herein are intended for use in surgical implants, life-support systems, aerospace equipment, nuclear power control systems, vehicles, disaster/crime-prevention equipment and the like, the failure of which may directly or indirectly cause injury, death or property loss.
- Anyone purchasing any products described or contained herein for an above-mentioned use shall:
 - ① Accept full responsibility and indemnify and defend SANYO ELECTRIC CO., LTD., its affiliates, subsidiaries and distributors and all their officers and employees, jointly and severally, against any and all claims and litigation and all damages, cost and expenses associated with such use:
 - ② Not impose any responsibility for any fault or negligence which may be cited in any such claim or litigation on SANYO ELECTRIC CO., LTD., its affiliates, subsidiaries and distributors or any of their officers and employees jointly or severally.
- Information (including circuit diagrams and circuit parameters) herein is for example only; it is not guaranteed for volume production. SANYO believes information herein is accurate and reliable, but no guarantees are made or implied regarding its use or any infringements of intellectual property rights or other rights of third parties.

This catalog provides information as of June, 1997. Specifications and information herein are subject to change without notice.