

---

# HD74LV74A

Dual D-type Flip Flops with Preset and Clear

# HITACHI

ADE-205-244 (Z)

1st Edition

March 1999

---

## Description

The HD74LV74A has independent data, preset, clear, and clock inputs Q and  $\bar{Q}$  outputs in a 14 pin package. The input data is transferred to the output at the rising edge of clock pulse CLK. Low-voltage and high-speed operation is suitable for the battery-powered products (e.g., notebook computers), and the low-power consumption extends the battery life.

## Features

- $V_{CC} = 2.0\text{ V}$  to  $5.5\text{ V}$  operation
- All inputs  $V_{IH}$  (Max.) =  $5.5\text{ V}$  (@  $V_{CC} = 0\text{ V}$  to  $5.5\text{ V}$ )
- All outputs  $V_O$  (Max.) =  $5.5\text{ V}$  (@  $V_{CC} = 0\text{ V}$ )
- Typical  $V_{OL}$  ground bounce <  $0.8\text{ V}$  (@  $V_{CC} = 3.3\text{ V}$ ,  $T_a = 25^\circ\text{C}$ )
- Typical  $V_{OH}$  undershoot >  $2.3\text{ V}$  (@  $V_{CC} = 3.3\text{ V}$ ,  $T_a = 25^\circ\text{C}$ )
- Output current  $\pm 6\text{ mA}$  (@  $V_{CC} = 3.0\text{ V}$  to  $3.6\text{ V}$ ),  $\pm 12\text{ mA}$  (@  $V_{CC} = 4.5\text{ V}$  to  $5.5\text{ V}$ )



## HD74LV74A

### Function Table

Inputs				Outputs	
PRE	$\overline{\text{CLR}}$	CLK	D	Q	$\overline{\text{Q}}$
L	H	X	X	H	L
H	L	X	X	L	H
L	L	X	X	H* <sup>1</sup>	H* <sup>1</sup>
H	H	↑	H	H	L
H	H	↑	L	L	H
H	H	↓	X	Q <sub>0</sub>	$\overline{\text{Q}}_0$

Note: H: High level

L: Low level

X: Immaterial

↑: Low to high transition

↓: High to low transition

Q<sub>0</sub>: The level of Q immediately before the input conditions shown in the above table are determined.

1.: Q and  $\overline{\text{Q}}$  will remain HIGH as long as Preset and Clear are Low, but Q and  $\overline{\text{Q}}$  are unpredictable, if Preset and Clear go HIGH simultaneously.

### Pin Arrangement

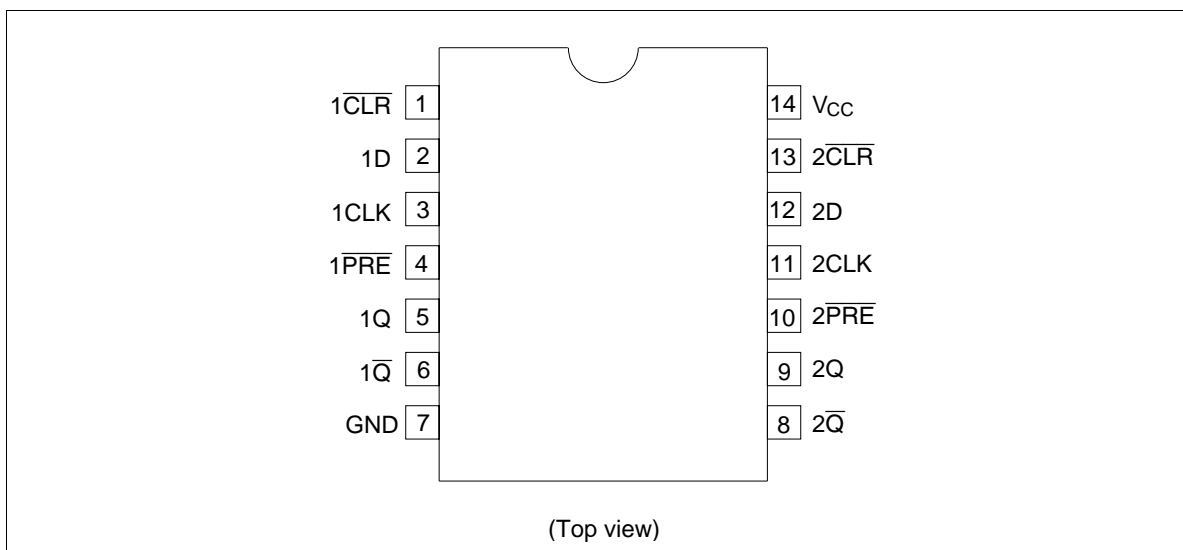

**Absolute Maximum Ratings**

Item	Symbol	Ratings	Unit	Conditions
Supply voltage range	$V_{CC}$	-0.5 to 7.0	V	
Input voltage range* <sup>1</sup>	$V_I$	-0.5 to 7.0	V	
Output voltage range* <sup>1,2</sup>	$V_O$	-0.5 to $V_{CC} + 0.5$ -0.5 to 7.0	V	Output: H or L $V_{CC}$ : OFF
Input clamp current	$I_{IK}$	-20	mA	$V_I < 0$
Output clamp current	$I_{OK}$	±50	mA	$V_O < 0$ or $V_O > V_{CC}$
Continuous output current	$I_O$	±25	mA	$V_O = 0$ to $V_{CC}$
Continuous current through $V_{CC}$ or GND	$I_{CC}$ or $I_{GND}$	±50	mA	
Maximum power dissipation at $T_a = 25^\circ\text{C}$ (in still air)* <sup>3</sup>	$P_T$	785	mW	SOP
		500		TSSOP
Storage temperature	$T_{stg}$	-65 to 150	°C	

Notes: The absolute maximum ratings are values which must not individually be exceeded, and furthermore, no two of which may be realized at the same time.

1. The input and output voltage ratings may be exceeded if the input and output clamp-current ratings are observed.
2. This value is limited to 5.5 V maximum.
3. The maximum package power dissipation was calculated using a junction temperature of 150°C.

---

## HD74LV74A

---

### Recommended Operating Conditions

Item	Symbol	Min	Max	Unit	Conditions
Supply voltage range	$V_{CC}$	2.0	5.5	V	
Input voltage range	$V_I$	0	5.5	V	
Output voltage range	$V_O$	0	$V_{CC}$	V	
Output current	$I_{OH}$	—	−50	$\mu\text{A}$	$V_{CC} = 2.0 \text{ V}$
		—	−2	$\text{mA}$	$V_{CC} = 2.3 \text{ to } 2.7 \text{ V}$
		—	−6		$V_{CC} = 3.0 \text{ to } 3.6 \text{ V}$
		—	−12		$V_{CC} = 4.5 \text{ to } 5.5 \text{ V}$
	$I_{OL}$	—	50	$\mu\text{A}$	$V_{CC} = 2.0 \text{ V}$
		—	2	$\text{mA}$	$V_{CC} = 2.3 \text{ to } 2.7 \text{ V}$
		—	6		$V_{CC} = 3.0 \text{ to } 3.6 \text{ V}$
		—	12		$V_{CC} = 4.5 \text{ to } 5.5 \text{ V}$
Input transition rise or fall rate	$\Delta t / \Delta v$	0	200	$\text{ns/V}$	$V_{CC} = 2.3 \text{ to } 2.7 \text{ V}$
		0	100		$V_{CC} = 3.0 \text{ to } 3.6 \text{ V}$
		0	20		$V_{CC} = 4.5 \text{ to } 5.5 \text{ V}$
Operating free-air temperature	$T_a$	−40	85	$^{\circ}\text{C}$	

Note: Unused or floating inputs must be held high or low.

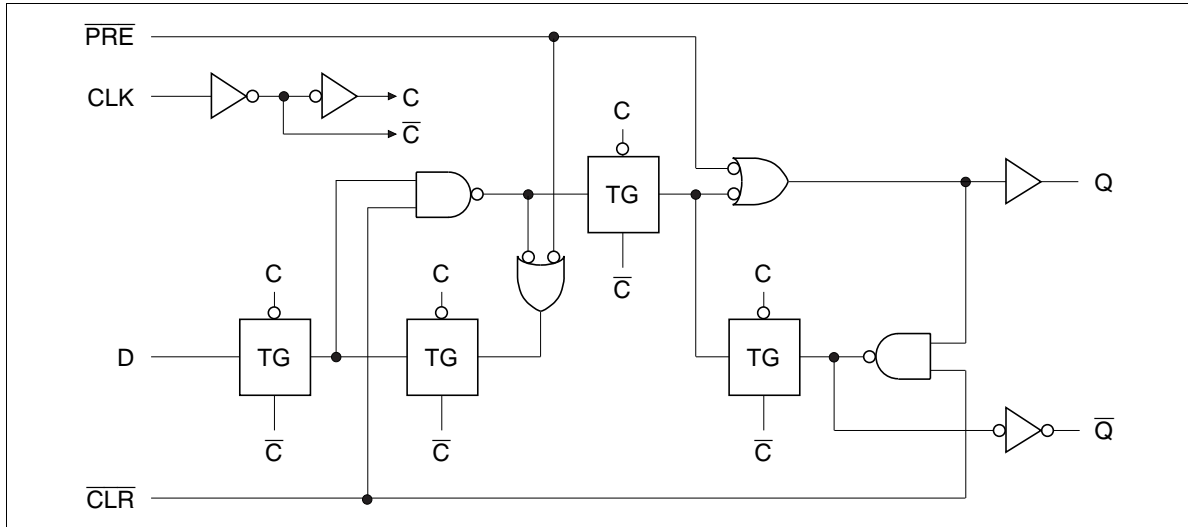
**Logic Diagram**

## HD74LV74A

### DC Electrical Characteristics

- $T_a = -40$  to  $85^\circ\text{C}$

Item	Symbol	$V_{CC}$ (V)*	Min	Typ	Max	Unit	Test Conditions	
Input voltage	$V_{IH}$	2.0	1.5	—	—	V		
		2.3 to 2.7	$V_{CC} \times 0.8$	—	—			
		3.0 to 3.6	$V_{CC} \times 0.8$	—	—			
		4.5 to 5.5	$V_{CC} \times 0.8$	—	—			
	$V_{IL}$	2.0	—	—	0.3			
		2.3 to 2.7	—	—	$V_{CC} \times 0.2$			
		3.0 to 3.6	—	—	$V_{CC} \times 0.2$			
		4.5 to 5.5	—	—	$V_{CC} \times 0.2$			
Output voltage	$V_{OH}$	Min to Max	$V_{CC} - 0.1$	—	—	V	$I_{OL} = -50 \mu\text{A}$	
		2.3	2.0	—	—		$I_{OL} = -2 \text{ mA}$	
		3.0	2.48	—	—		$I_{OL} = -6 \text{ mA}$	
		4.5	3.8	—	—		$I_{OL} = -12 \text{ mA}$	
	$V_{OL}$	Min to Max	—	—	0.1		V	$I_{OL} = 50 \mu\text{A}$
		2.3	—	—	0.4			$I_{OL} = 2 \text{ mA}$
		3.0	—	—	0.44			$I_{OL} = 6 \text{ mA}$
		4.5	—	—	0.55			$I_{OL} = 12 \text{ mA}$
Input current	$I_{IN}$	0 to 5.5	—	—	$\pm 1$	$\mu\text{A}$		$V_{IN} = 5.5 \text{ V}$ or GND
Quiescent supply current	$I_{CC}$	5.5	—	—	20	$\mu\text{A}$		$V_{IN} = V_{CC}$ or GND, $I_O = 0$
Output leakage current	$I_{OFF}$	0	—	—	5	$\mu\text{A}$		$V_O = 5.5 \text{ V}$
Input capacitance	$C_{IN}$	3.3	—	2.0	—	pF		$V_I = V_{CC}$ or GND

Note: For conditions shown as Min or Max, use the appropriate values under recommended operating conditions.

**Switching Characteristics**

- $V_{CC} = 2.5 \pm 0.2 \text{ V}$

Item	Symbol	Ta = 25°C			Ta = -40 to 85°C		Unit	Test Conditions	FROM (Input)	TO (Output)
		Min	Typ	Max	Min	Max				
Maximum clock frequency	$t_{max}$	50	100	—	40	—	MHz	$C_L = 15 \text{ pF}$		
		30	70	—	25	—				
Propagation delay time	$t_{PLH}$	—	9.8	14.8	1.0	17.0	ns	$C_L = 15 \text{ pF}$	$\overline{\text{PRE}}/\overline{\text{CLR}}$	Q or $\overline{\text{Q}}$
		—	11.1	16.4	1.0	19.0			CLK	
	$t_{PHL}$	—	13.0	17.4	1.0	20.0	$C_L = 50 \text{ pF}$	$\overline{\text{PRE}}/\overline{\text{CLR}}$	Q or $\overline{\text{Q}}$	
		—	14.2	20.0	1.0	23.0		CLK		
Setup time	$t_{su}$	8.0	—	—	9.0	—	ns	Data		
		7.0	—	—	7.0	—		$\overline{\text{PRE}}$ or $\overline{\text{CLR}}$ inactive		
Hold time	$t_h$	0.5	—	—	0.5	—	ns			
Pulse width	$t_w$	8.0	—	—	9.0	—	ns	$\overline{\text{PRE}}$ or $\overline{\text{CLR}}$ "L"		
		8.0	—	—	9.0	—		CLK "H" or "L"		

## HD74LV74A

### Switching Characteristics (cont)

- $V_{CC} = 3.3 \pm 0.3$  V

Item	Symbol	Ta = 25°C			Ta = -40 to 85°C		Unit	Test Conditions	FROM (Input)	TO (Output)
		Min	Typ	Max	Min	Max				
Maximum clock frequency	$t_{max}$	80	140	—	70	—	MHz	$C_L = 15$ pF		
		50	90	—	45	—				
Propagation delay time	$t_{PLH}$	—	6.9	12.3	1.0	14.5	ns	$C_L = 15$ pF	$\overline{PRE}/\overline{CLR}$	Q or $\overline{Q}$
		—	7.9	11.9	1.0	14.0			CLK	
	$t_{PHL}$	—	9.2	15.8	1.0	18.0	$C_L = 50$ pF	$\overline{PRE}/\overline{CLR}$	Q or $\overline{Q}$	
		—	10.2	15.4	1.0	17.5		CLK		
Setup time	$t_{su}$	6.0	—	—	7.0	—	ns	Data		
		5.0	—	—	5.0	—		$\overline{PRE}$ or $\overline{CLR}$ inactive		
Hold time	$t_h$	0.5	—	—	0.5	—	ns			
Pulse width	$t_w$	6.0	—	—	7.0	—	ns	$\overline{PRE}$ or $\overline{CLR}$ "L"		
		6.0	—	—	7.0	—		CLK "H" or "L"		



**Switching Characteristics (cont)**

- $V_{CC} = 5.0 \pm 0.5 \text{ V}$

Item	Symbol	Ta = 25°C			Ta = -40 to 85°C		Unit	Test Conditions	FROM (Input)	TO (Output)
		Min	Typ	Max	Min	Max				
Maximum clock frequency	$t_{max}$	130	180	—	110	—	MHz	$C_L = 15 \text{ pF}$		
		90	140	—	75	—				
Propagation delay time	$t_{PLH}$	—	5.0	7.7	1.0	9.0	ns	$C_L = 15 \text{ pF}$	$\overline{\text{PRE}}/\overline{\text{CLR}}$	Q or $\overline{\text{Q}}$
		—	5.6	7.3	1.0	8.5			CLK	
	$t_{PHL}$	—	6.6	9.7	1.0	11.0	$C_L = 50 \text{ pF}$	$\overline{\text{PRE}}/\overline{\text{CLR}}$	Q or $\overline{\text{Q}}$	
		—	7.2	9.3	1.0	10.5		CLK		
Setup time	$t_{su}$	5.0	—	—	5.0	—	ns	Data		
		3.0	—	—	3.0	—		$\overline{\text{PRE}}$ or $\overline{\text{CLR}}$ inactive		
Hold time	$t_h$	0.5	—	—	0.5	—	ns			
Pulse width	$t_w$	5.0	—	—	5.0	—	ns	$\overline{\text{PRE}}$ or $\overline{\text{CLR}}$ "L"		
		5.0	—	—	5.0	—		CLK "H" or "L"		

---

---

## HD74LV74A

---

### Operating Characteristics

- $C_L = 50 \text{ pF}$

Item	Symbol	$V_{CC}$ (V)	$T_a = 25^\circ\text{C}$			Unit	Test Conditions
			Min	Typ	Max		
Power dissipation capacitance	$C_{PD}$	3.3	—	21.0	—	pF	f = 10 MHz
		5.0	—	23.0	—		

---

### Noise Characteristics

- $C_L = 50 \text{ pF}$

Item	Symbol	$V_{CC}$ (V)	$T_a = 25^\circ\text{C}$			Unit	Test Conditions
			Min	Typ	Max		
Quiet output, maximum dynamic $V_{OL}$	$V_{OL(P)}$	3.3	—	0.1	0.8	V	
Quiet output, minimum dynamic $V_{OL}$	$V_{OL(V)}$	3.3	—	0	-0.8		
Quiet output, minimum dynamic $V_{OH}$	$V_{OH(V)}$	3.3	—	3.2	—	V	
High-level dynamic input voltage	$V_{IH(D)}$	3.3	2.31	—	—		
Low-level dynamic input voltage	$V_{IL(D)}$	3.3	—	—	0.99		

---

**Test Circuit**

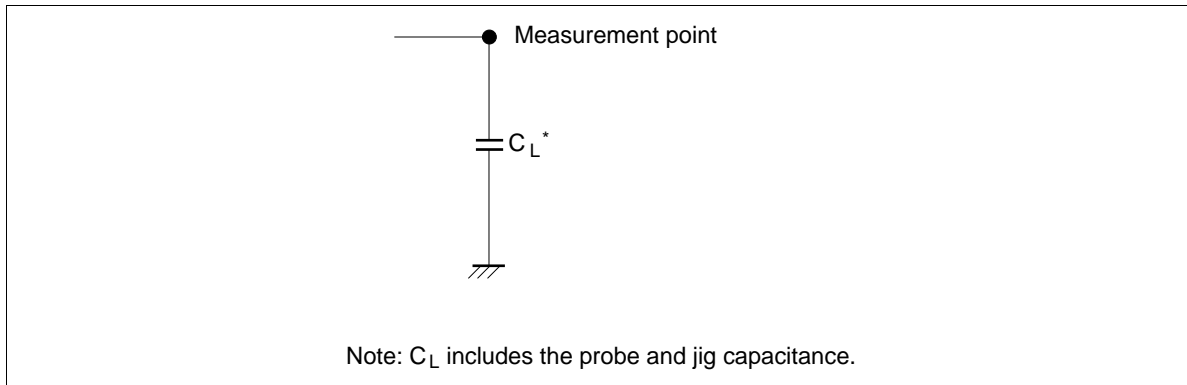

## HD74LV74A

### • Waveform – 1

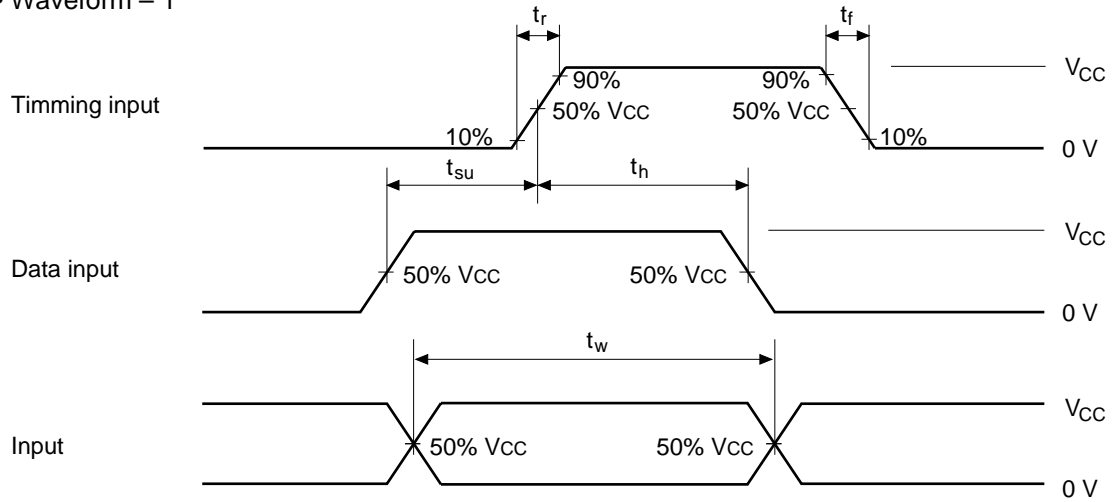

### • Waveform – 2

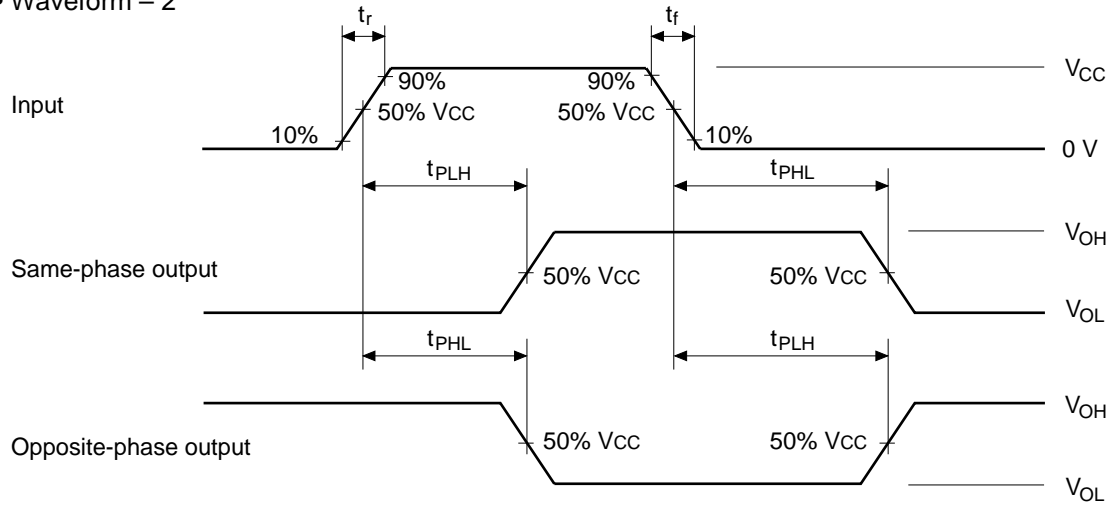

- Notes: 1. Input waveform:  $PRR \leq 1\text{ MHz}$ ,  $Z_o = 50\ \Omega$ ,  $t_r \leq 3\text{ ns}$ ,  $t_f \leq 3\text{ ns}$   
 2. The output are measured one at a time with one transition per measurement.

Package Dimensions

Unit: mm

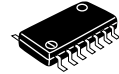
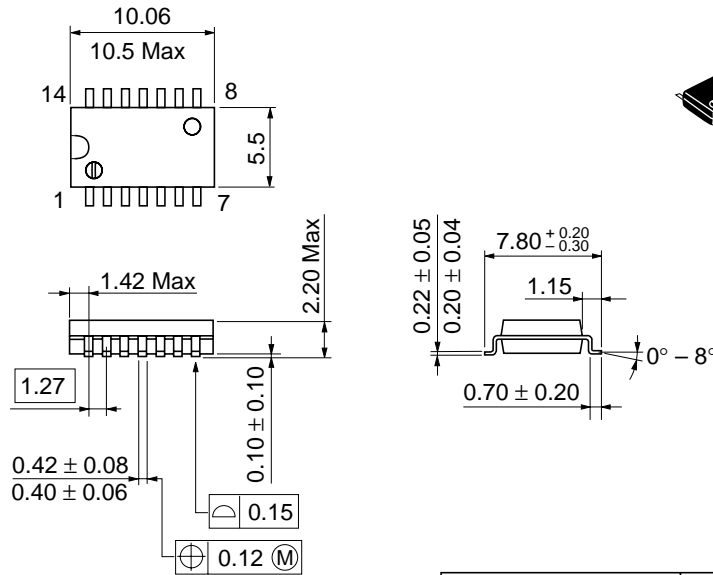

Dimension including the plating thickness  
Base material dimension

Hitachi Code	FP-14DA
JEDEC	—
EIAJ	Conforms
Weight (reference value)	0.23 g

# HD74LV74A

Unit: mm

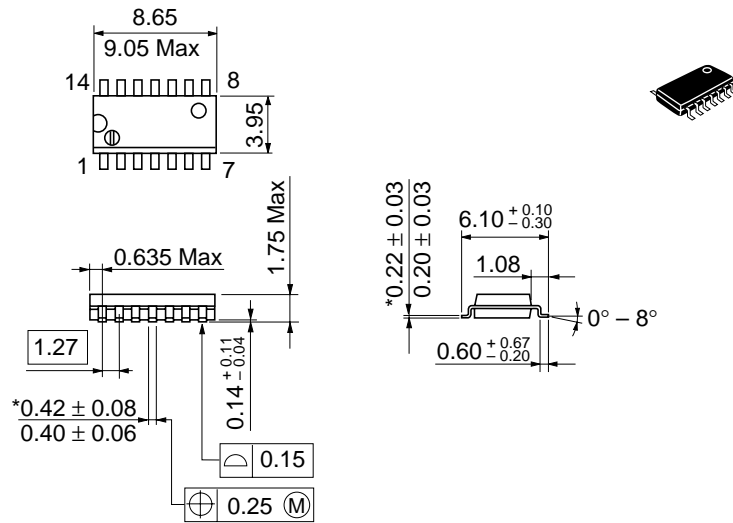

\*Dimension including the plating thickness  
Base material dimension

Hitachi Code	FP-14DN
JEDEC	Conforms
EIAJ	Conforms
Weight (reference value)	0.13 g

# HD74LV74A

Unit: mm

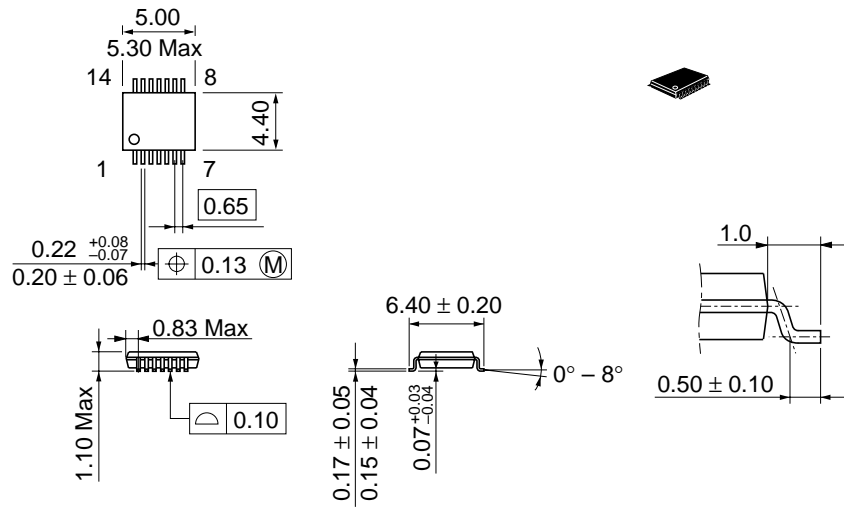

Dimension including the plating thickness  
Base material dimension

Hitachi Code	TTP-14D
JEDEC	—
EIAJ	—
Weight (reference value)	0.05 g

---

---

## Cautions

1. Hitachi neither warrants nor grants licenses of any rights of Hitachi's or any third party's patent, copyright, trademark, or other intellectual property rights for information contained in this document. Hitachi bears no responsibility for problems that may arise with third party's rights, including intellectual property rights, in connection with use of the information contained in this document.
2. Products and product specifications may be subject to change without notice. Confirm that you have received the latest product standards or specifications before final design, purchase or use.
3. Hitachi makes every attempt to ensure that its products are of high quality and reliability. However, contact Hitachi's sales office before using the product in an application that demands especially high quality and reliability or where its failure or malfunction may directly threaten human life or cause risk of bodily injury, such as aerospace, aeronautics, nuclear power, combustion control, transportation, traffic, safety equipment or medical equipment for life support.
4. Design your application so that the product is used within the ranges guaranteed by Hitachi particularly for maximum rating, operating supply voltage range, heat radiation characteristics, installation conditions and other characteristics. Hitachi bears no responsibility for failure or damage when used beyond the guaranteed ranges. Even within the guaranteed ranges, consider normally foreseeable failure rates or failure modes in semiconductor devices and employ systemic measures such as fail-safes, so that the equipment incorporating Hitachi product does not cause bodily injury, fire or other consequential damage due to operation of the Hitachi product.
5. This product is not designed to be radiation resistant.
6. No one is permitted to reproduce or duplicate, in any form, the whole or part of this document without written approval from Hitachi.
7. Contact Hitachi's sales office for any questions regarding this document or Hitachi semiconductor products.

---

---

# HITACHI

## Hitachi, Ltd.

Semiconductor & Integrated Circuits.  
Nippon Bldg., 2-6-2, Ohte-machi, Chiyoda-ku, Tokyo 100-0004, Japan  
Tel: Tokyo (03) 3270-2111 Fax: (03) 3270-5109

URL      NorthAmerica      : <http://semiconductor.hitachi.com/>  
             Europe                : <http://www.hitachi-eu.com/hel/ecg>  
             Asia (Singapore)      : <http://www.has.hitachi.com.sg/grp3/sicd/index.htm>  
             Asia (Taiwan)            : [http://www.hitachi.com.tw/E/Product/SICD\\_Frame.htm](http://www.hitachi.com.tw/E/Product/SICD_Frame.htm)  
             Asia (HongKong)        : <http://www.hitachi.com.hk/eng/bo/grp3/index.htm>  
             Japan                      : <http://www.hitachi.co.jp/Sicd/indx.htm>

### For further information write to:

Hitachi Semiconductor  
(America) Inc.  
179 East Tasman Drive,  
San Jose, CA 95134  
Tel: <1> (408) 433-1990  
Fax: <1> (408) 433-0223

Hitachi Europe GmbH  
Electronic components Group  
Dornacher StraÙe 3  
D-85622 Feldkirchen, Munich  
Germany  
Tel: <49> (89) 9 9180-0  
Fax: <49> (89) 9 29 30 00  
  
Hitachi Europe Ltd.  
Electronic Components Group.  
Whitebrook Park  
Lower Cookham Road  
Maidenhead  
Berkshire SL6 8YA, United Kingdom  
Tel: <44> (1628) 585000  
Fax: <44> (1628) 778322

Hitachi Asia Pte. Ltd.  
16 Collyer Quay #20-00  
Hitachi Tower  
Singapore 049318  
Tel: 535-2100  
Fax: 535-1533

Hitachi Asia Ltd.  
Taipei Branch Office  
3F, Hung Kuo Building, No.167,  
Tun-Hwa North Road, Taipei (105)  
Tel: <886> (2) 2718-3666  
Fax: <886> (2) 2718-8180

Hitachi Asia (Hong Kong) Ltd.  
Group III (Electronic Components)  
7/F., North Tower, World Finance Centre,  
Harbour City, Canton Road, Tsim Sha Tsui,  
Kowloon, Hong Kong  
Tel: <852> (2) 735 9218  
Fax: <852> (2) 730 0281  
Telex: 40815 HITEC HX