

Hyper TOPLED® White LED

LW T676

Vorläufige Daten / Preliminary Data

Besondere Merkmale

- GaN-Technologie
- Farbe: weiß $x = 0.30$, $y = 0.32$ nach CIE1931
- Abstrahlcharakteristik: Lambertscher Strahler (120°)
- ESD-sicher bis 2 kV nach MIL STD 883D, Method 3015.7
- JEDEC Level 2
- weißes SMT-Gehäuse
- Für alle SMT-Bestück- und Löttechniken geeignet
- Gegurtet in 8 mm-Filmgurt

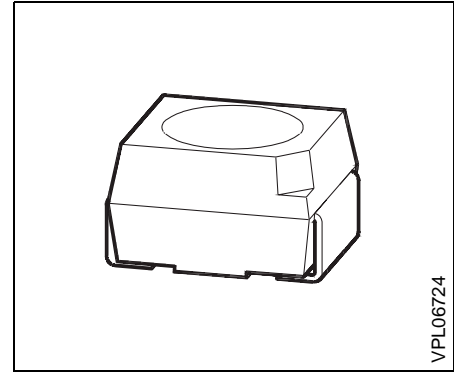

Features

- GaN technology
- color: white $x = 0.30$, $y = 0.32$ according to CIE1931
- viewing angle: Lambertian Emitter (120°)
- ESD withstand voltage of 2 kV according to MIL STD 883D, Method 3015.7
- JEDEC Level 2
- white colored SMT package
- suitable for all SMT assembly and soldering methods
- available on 8 mm tape reels

Anwendungen

- Innenbeleuchtungen und Hinterleuchtungen im Automobilbereich
- Anzeigen im Innen und Außenbereich
- LCD-Hinterleuchtungen
- Schalter-Hinterleuchtungen
- Batterie-Taschenlampen
- Notausgangsbeleuchtungen
- Leselampen
- Sehr gute Alternative zur Glühlampe

Applications

- illuminations and backlighting for interior automotive applications
- indoor and outdoor message boards
- LCD backlighting
- switch backlighting
- battery torches
- emergency exit illuminations
- lamps for reading purposes
- very good alternative to incandescent lamps

Typ	Emissions- farbe	Farbe der Lichtaustritts- fläche	Lichtstärke	Lichtstrom	Bestellnummer
Type	Color of Emission	Color of the Light Emitting Area	Luminous Intensity $I_F = 10 \text{ mA}$ $I_V \text{ (mcd)}$	Luminous Flux $I_F = 10 \text{ mA}$ $\Phi_V \text{ (mlm)}$	Ordering Code
LW T676	white	colored diffused			Q62703-Q4450
LW T676-L2			12.5 ... 20.0	50 (typ.)	
LW T676-M1			16.0 ... 25.0	60 (typ.)	
LW T676-M2			20.0 ... 32.0	80 (typ.)	
LW T676-N1			25.0 ... 40.0	100 (typ.)	

Streuung der Lichtstärke in einer Verpackungseinheit $I_{V \max} / I_{V \min} \leq 1.6$.

Luminous intensity ratio in one packaging unit $I_{V \max} / I_{V \min} \leq 1.6$.

Helligkeitswerte werden bei einer Strompulsdauer von 25 ms spezifiziert.

Luminous intensity is specified at a current pulse duration of 25 ms.

Grenzwerte Maximum Ratings

Bezeichnung Parameter	Symbol Symbol	Werte Values	Einheit Unit
Betriebstemperatur Operating temperature range	T_{op}	- 40 ... + 100	°C
Lagertemperatur Storage temperature range	T_{stg}	- 40 ... + 100	°C
Sperrschichttemperatur Junction temperature	T_j	+ 100	°C
Durchlaßstrom Forward current	I_F	20	mA
Sperrspannung ¹⁾ Reverse voltage ¹⁾	V_R	5	V
Verlustleistung Power dissipation $T_A \leq 25 \text{ °C}$	P_{tot}	90	mW
Wärmewiderstand Thermal resistance Sperrschicht / Umgebung Junction / air Montage auf PC-board*) (Padgröße $\geq 16 \text{ mm}^2$) mounted on PC board*) (pad size $\geq 16 \text{ mm}^2$)	$R_{th JA}$	500	K/W

1) Belastung in Sperrichtung sollte vermieden werden.

1) Reverse biasing should be avoided.

*) PC-board: FR4

Kennwerte ($T_A = 25\text{ °C}$)

Characteristics

Bezeichnung Parameter	Symbol Symbol	Werte Values		Einheit Unit
		typ.	max.	
Farbkoordinate x nach CIE 1931 ¹⁾ Chromaticity coordinate x acc. to CIE 1931 ¹⁾ $I_F = 10\text{ mA}$	x	0.300	–	–
Farbkoordinate y nach CIE 1931 ¹⁾ Chromaticity coordinate y acc. to CIE 1931 ¹⁾ $I_F = 10\text{ mA}$	y	0.320	–	–
Abstrahlwinkel bei 50% I_v (Vollwinkel) Viewing angle at 50% I_v	2ϕ	120	–	Grad deg.
Durchlaßspannung Forward voltage $I_F = 10\text{ mA}$	V_F	3.5	4.2	V
Sperrstrom Reverse current $V_R = 5\text{ V}$	I_R	0.01	10	μA
Temperaturkoeffizient von x ($I_F = 10\text{ mA}$) Temperature coefficient of x ($I_F = 10\text{ mA}$)	TC_x	0.07	–	$10^{-3}/\text{K}$
Temperaturkoeffizient von y ($I_F = 10\text{ mA}$) Temperature coefficient of y ($I_F = 10\text{ mA}$)	TC_y	0.25	–	$10^{-3}/\text{K}$
Temperaturkoeffizient von V_F ($I_F = 10\text{ mA}$) Temperature coefficient of V_F ($I_F = 10\text{ mA}$)	TC_V	– 3.1	–	mV/K

¹⁾ **Farbortgruppen**

Chromaticity coordinate groups

Gruppe Group	x		y	
	min.	max.	min.	max.
1	0.280	0.325	0.300	0.350
2	0.285	0.330	0.330	0.380
3	0.295	0.340	0.345	0.395
4	0.270	0.315	0.285	0.335

Relative spektrale Emission $I_{rel} = f(\lambda)$, $T_A = 25\text{ °C}$, $I_F = 10\text{ mA}$

Relative spectral emission

$V(\lambda) =$ spektrale Augenempfindlichkeit

Standard eye response curve

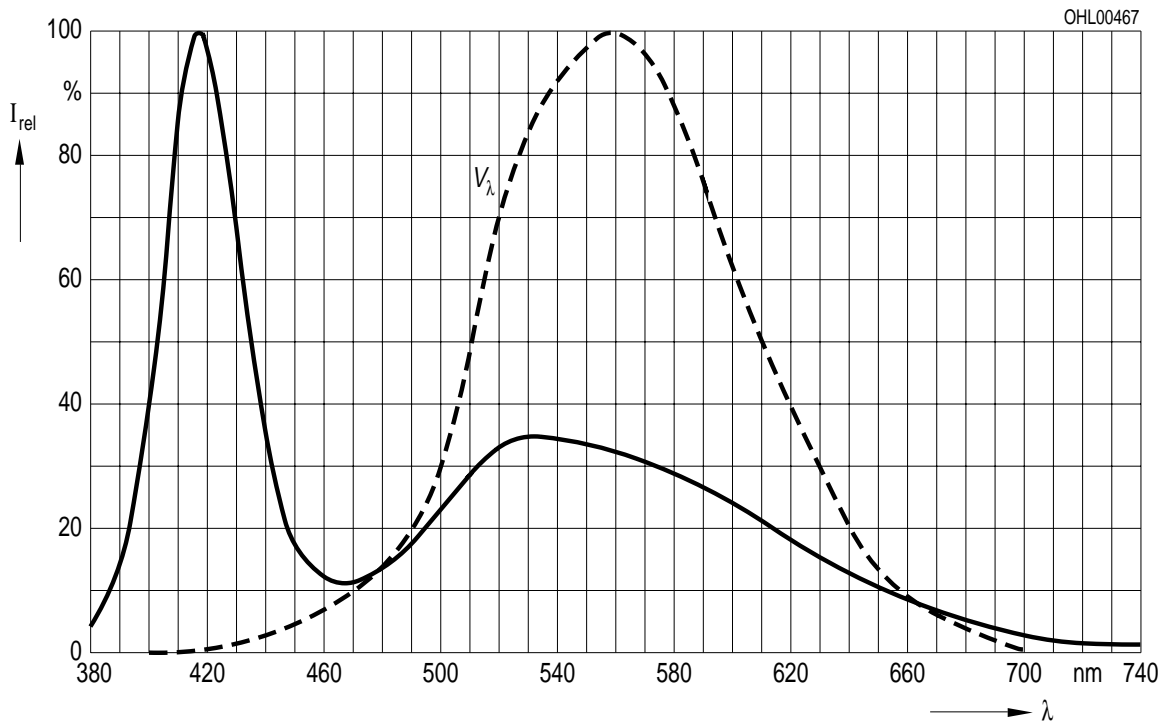

Abstrahlcharakteristik $I_{rel} = f(\varphi)$

Radiation characteristic

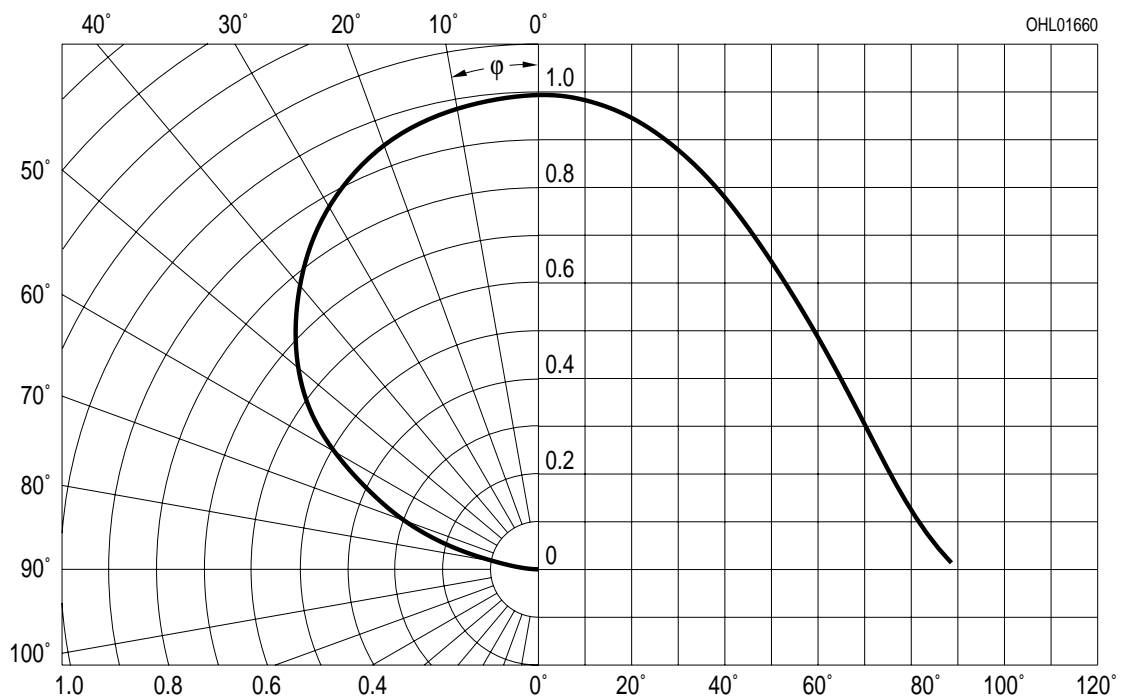

Durchlaßstrom $I_F = f(V_F)$
Forward current
 $T_A = 25\text{ °C}$

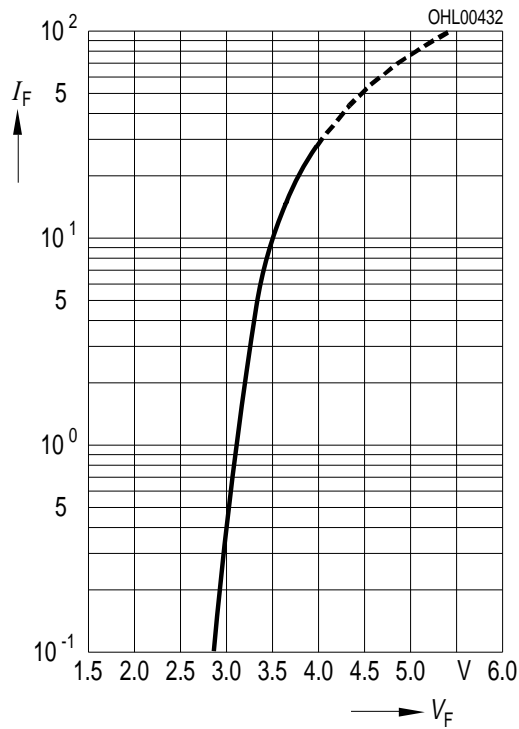

Relative Lichtstärke $I_V/I_{V(10\text{ mA})} = f(I_F)$
Relative luminous intensity
 $T_A = 25\text{ °C}$

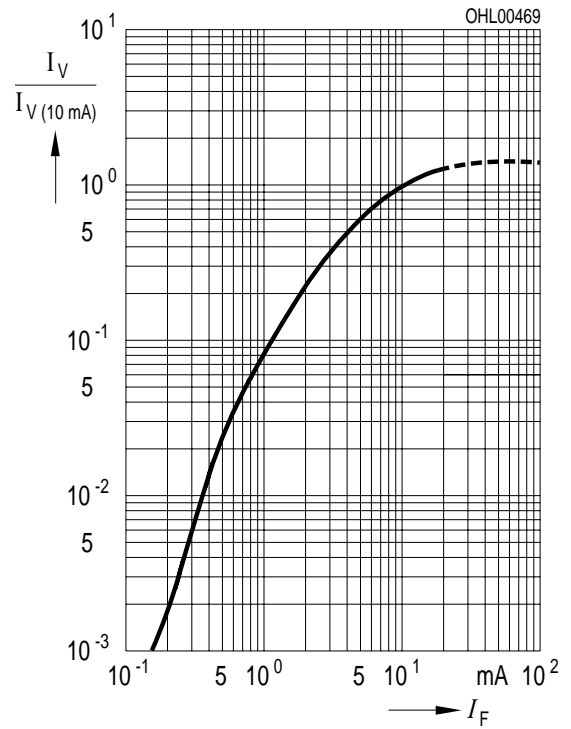

Maximal zulässiger Durchlaßstrom
Max. permissible forward current
 $I_F = f(T_A)$



Relative Lichtstärke $I_V/I_{V(25\text{ °C})} = f(T_A)$
Relative luminous intensity
 $I_F = 10\text{ mA}$

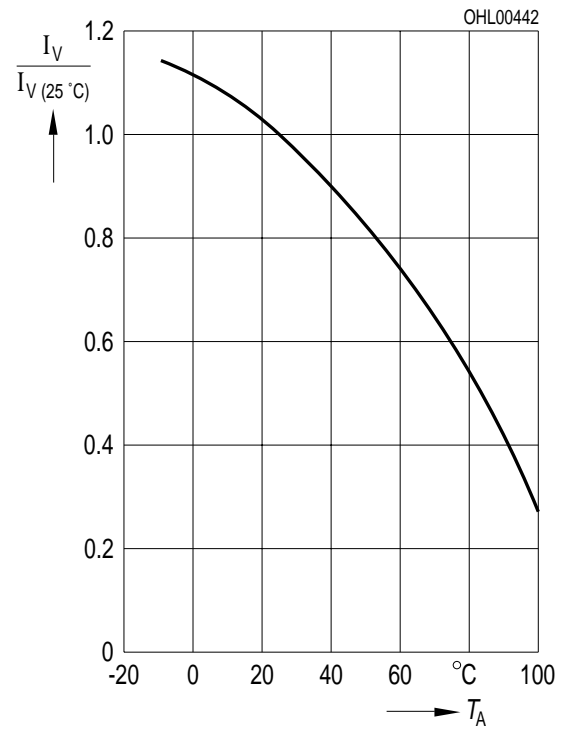

Maßzeichnung (Maße in mm, wenn nicht anders angegeben)
Package Outlines (Dimensions in mm, unless otherwise specified)

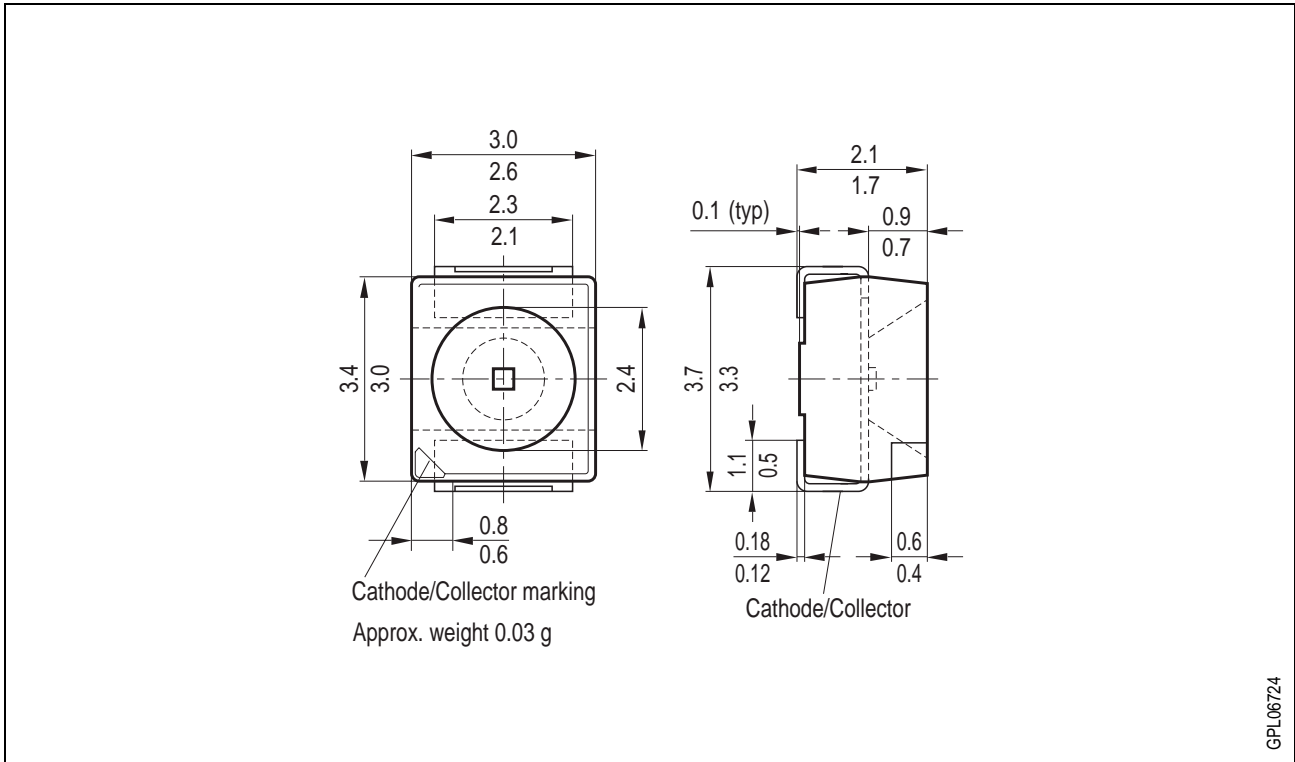

GPL06724

Kathodenkennung: abgeschrägte Ecke
Cathode mark: bevelled edge