



CLARE

M-980-02 3V/5V General Purpose Call Progress Tone Detector

Features

- Covers the 315 to 640 Hz range (common call progress)
- Sensitivity to -38 dBm
- Dynamic range over 38 dB
- 40 ms minimum detect
- 8-pin DIP or 16-pin SOIC
- Single supply CMOS (low power)
- Supply range 2.8 to 5.5 VDC
- Inexpensive 3.58 MHz time base
- Low power consumption (<_15 mW at 3V)

Applications

- Automatic dialers
- Dialing modems
- Traffic measurement equipment
- Test equipment
- Service evaluation
- Billing systems

Description

The M-980-02 is an integrated circuit tone detector for general purpose use in automatic following of switched telephone calls. The circuit uses low-power CMOS techniques to provide the complete filtering and control required for this function. The basic timing of the M-980-02 is designed to permit operation with almost any progress tone system.

The use of integrated circuit techniques allows the M-980-02 to pack the complete frequency and amplitude portion of call progress following into a single 8-pin DIP or 16-pin SOIC. A 3.58 MHz crystal-controlled time base guarantees accuracy and repeatability. 3V/5V operation increases customer flexibility, improves reliability, and minimizes power consumption.

Pin Diagram

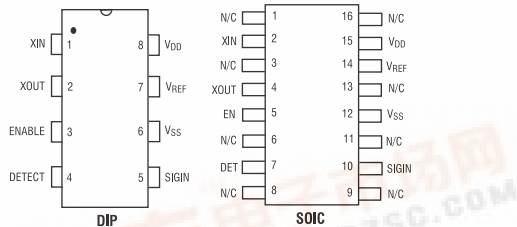

Ordering Information

Part #	Description
M-980-02P	8-pin plastic DIP
M-980-02S	16-pin SOIC
M-980-02T	16-pin SOIC, Tape and Reel

Block Diagram

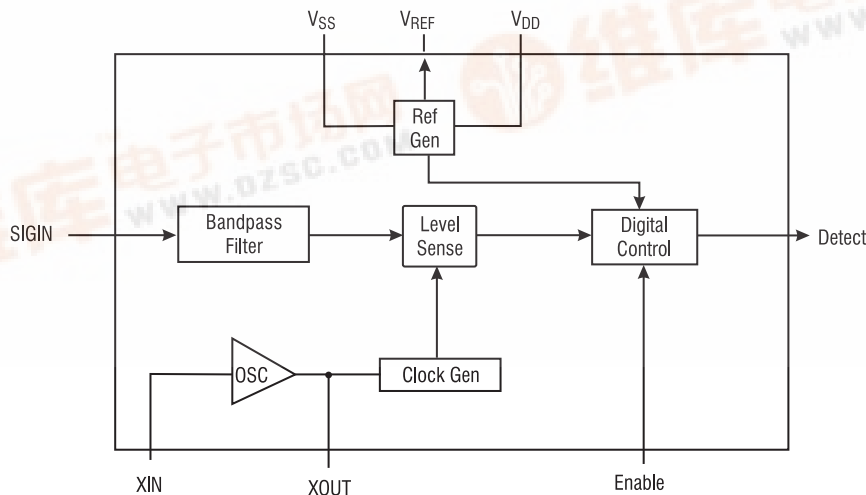



M-980-02

Absolute Maximum Ratings

DC Supply Voltage ($V_{DD} - V_{SS}$)	6.0V
Voltage on SIGNAL IN ($V_{DD} + 0.5V$) to ($V_{SS} - 12V$)	
Voltage on Any Pin Except SIGNAL IN	$(V_{DD} + 0.5V)$ to $V_{SS} - 0.5V$
Storage Temperature Range	-65° to 150°C
Operating Temperature	-40°C to 85°C
Lead Soldering Temperature	260° for 5 seconds

Note:

Exceeding these ratings may permanently damage the M-980-02.

Absolute Maximum Ratings are stress ratings. Stresses in excess of these ratings can cause permanent damage to the device. Functional operation of the device at these or any other conditions beyond those indicated in the operational sections of this data sheet is not implied. Exposure of the device to the absolute maximum ratings for an extended period may degrade the device and effect its reliability.

Specifications

Parameter		Min	Max	Units	Notes	
Supply Current		-	5	mA	10-	
Signal Detection	Level (5V)	-38	0	dBm	1,2	
	Level (3V)	-40	0	dBm	-	
	Duration	40	-	ms	-	
Signal Rejection	Level	Inband (5V)	-	-50	dBm	1,2
		Inband (3V)	-	-55	dBm	-
		Outband	-	0	dBm	1,3
Quiet Interval Detect	Duration	40	-	ms	8	
		85	-	ms	9	
"Detect" Output Pin	Logic 0	-	0.5	V	4	
	Logic 1	$V_{DD} - 0.5$	-	V	4	
"Enable", "XIN" Input Pin	Logic 0	V_{SS}	$V_{SS} + 0.2$	V	5	
	Logic 1	$V_{DD} - 0.2$	V_{DD}	V	5	
"XIN" Duty Cycle		40	60	%	6	
"XOUT" Loading		-	10	pF	-	
"VREF" Output Pin	Deviation	-2	+2	%	7	
	Resistance	3.25	6.75	k Ω	-	
"SIGIN" Input Pin	AC + DC level	$V_{SS} - 5V$	V_{DD}	V	-	
	Impedance (500 Hz)	80	-	k Ω	-	
Power Consumption	3V operation	-	15	mW	-	
	5V operation	-	25	mW	-	

Unless otherwise noted, $V_{DD} - V_{SS} = 2.8$ to 5.5 V and $T_a = 25^\circ\text{C}$

Notes:

- 0 dBm = 0.775 Vrms.
- F = 315 to 640 Hz.
- F > 1025 Hz, < 190 Hz.
- Output current = 1 mA, $V_{SS} - V_{DD} - 3.0V$.
- Input current - 10 mA max.
- External clock.
- Nominal = $(V_{DD} + V_{SS})/2$.
- Signal dropping from -38 to -65 dBm.
- Signal dropping from -10 to -65 dBm.

Pin Description

Pin	Descriptions
SIGIN	Signal input AC or DC coupled (see level limitations elsewhere).
DETECT	Active output indicating signal detection. Activated by ENABLE.
ENABLE	Enables DETECT output. Used to mask signal activity.
V_{DD}	Most positive power supply pin.
V_{REF}	Internally generated reference voltage. $(V_{SS} + V_{DD}) / 2$ volts.
V_{SS}	Most negative power supply pin.
XIN, XOUT	Crystal attachment pins. XIN may be used as the input for an external 3.58 MHz clock.

Signal Timing

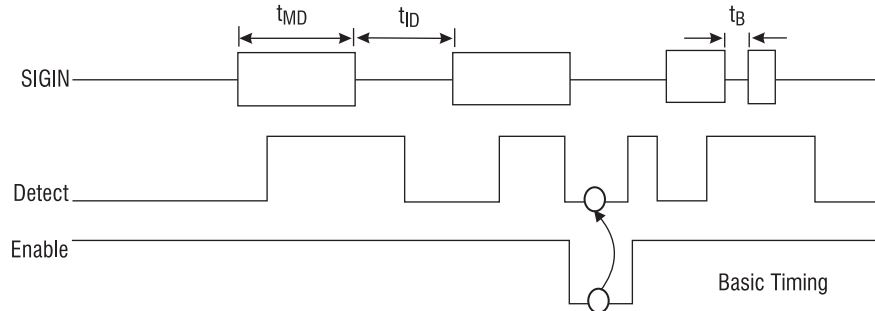

Call Progress Tone Detection

Call progress tones are audible tones sent from switching systems to calling parties to show the status of calls. Calling parties can identify the success of a call placed by what is heard after dialing. The type of tone used and its timing vary from system to system, and though intended for human ears these signals can provide valuable information for automated calling systems.

The M-980-02 is a signal detector sensitive to the frequencies most often used for these progress tones. Electronic equipment monitoring the DETECT output of the M-980-02 can determine the nature of signals present by measuring their duty cycle. See Figure 4 for a diagram of a circuit that could be used to permit a microcomputer to directly monitor tones on the telephone line. Much of the character of the progress tones is in their duty cycle or cadence (sometimes referred to as interruption rate). This information, coupled with level and frequency indication from the M-980-02, can be used to decide what progress tones have been encountered.

Table 5 shows some call progress tones with on/off times; 0.25/0.25 being 250 ms on, 250 ms off on a repeating basis. For example, dial tones as shown in the table are usually “on” continuously and last until the first dial digit is received by the switching system. Line Busy, on the other hand, is turned off and on at a rate of 1 Hz with a 50% duty cycle, or an interruption rate of

60 times per minute (60 IPM). The tones can be distinguished in this way.

It should be noted that while such techniques will usually be effective, there are some circumstances in which the M-980-02 cannot be accurately used. Examples include situations where ringback tone may be short or not even encountered. Ringback may be provided at ringing voltage frequency (20 or 30 Hz) with some harmonics and may not fall in the detect range, and speech or other strong noise may obscure tones making cadence measurement difficult.

Detection of “answer” is most difficult for many reasons. One way to determine if a called party has answered is by looking for a short burst of DETECT indications without a cadence match (produced by a click and “hello” at the far end). Some applications will require special methods like speech detection, but most can be reliably handled with the M-980-02 and simple cadence measurement.

As can be seen, the tones used for the same purposes in different systems may not be the same. Standards do exist and should be consulted for your particular application. In North America AT&Ts “Notes on the Network” or EIAs RS-464 PBX standard should be reviewed. In Europe tone plans may vary with locale, in which case the CEPT administration in each country must be consulted. Outside these areas, national PTT organizations can provide information on the systems within their borders.

Device Timing

Time	Value	Significance
t_{MD}	40 ms	A valid tone will always be detected if it is at least 40 ms long.
t_{ID}	40 ms @ -38 dBm	Inter-tone gaps must be detected if greater than this duration.
	85 ms @ -10 dBm	
t_B	18 ms	Drop-outs of valid tone of up to 18 ms will be ignored.

Note:

Application or removal of high level signals outside the must detect range may cause momentary detection, which may be filtered by time guarding the output.

Call Progress Tones

Frequency 1	Frequency 2	On/Off	Use
350	+440	Continuous	Dial tones
425	-	-	-
600	X 120	-	-
400	-	-	-
480	+620	0.5/0.5s	Line Busy Tones
600	X 120	-	-
480	+620	0.25/0.25s	Reorder Tones
600	X 120	-	-
440	+ 480	2.0/4.0s	Audible Ringing
500	X 40	-	-
440	-	0.5s burst	Various

Telephone Line Circuit Application

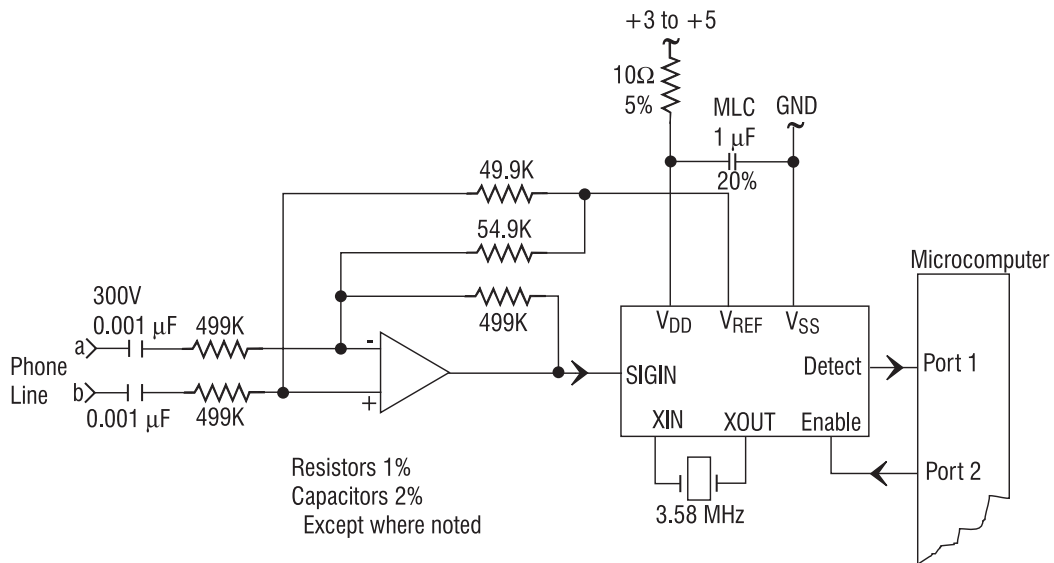

Detect Range

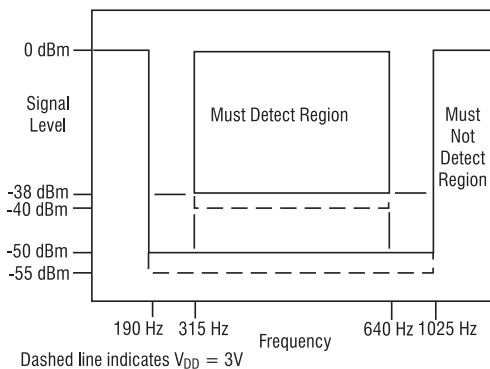

Input Signal Configuration

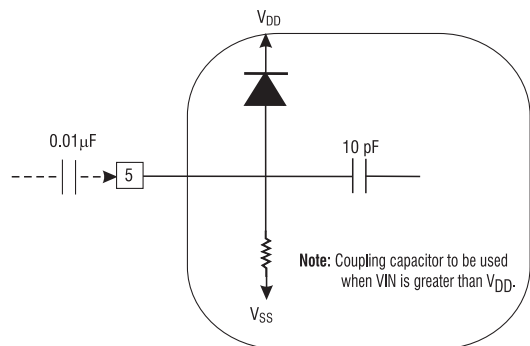

Mechanical Dimensions

8-Pin DIP

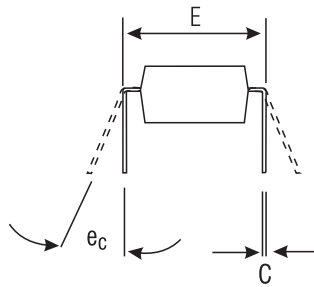
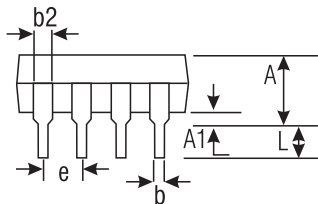
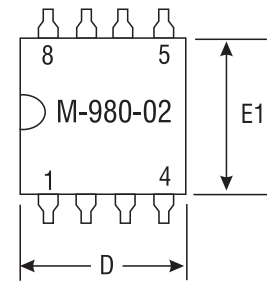

16-Pin SOIC

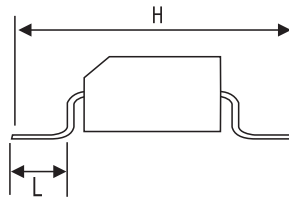
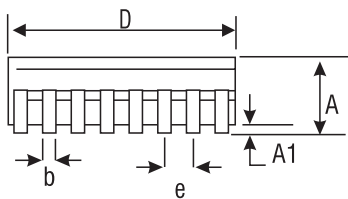
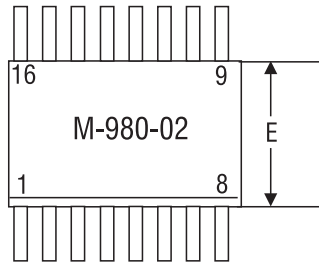

Drawing not to scale.
Does not reflect actual part marking.

	Tolerances			
	Inches		Metric (mm)	
	Min	Max	Min	Max
A	-	.210	-	5.33
A1	.015	-	.38	-
b	.014	.022	.36	.56
b2	.045	.070	1.1	1.8
C	.008	.014	.20	.36
D	.355	.400	9.02	10.16
E	.300	.325	7.6	8.3
E1	.240	.280	6.1	7.1
e	.100 BSC		2.54 BSC	
ec	0°	15°	0°	15°
L	.115	.150	2.9	4.1

	Tolerances			
	Inches		Metric (mm)	
	Min	Max	Min	Max
A	.0926	.1043	2.35	2.65
A1	.0040	.0118	.10	.30
b	.013	.020	.33	.51
D	.3977	.4133	10.10	10.50
E	.2914	.2992	7.4	7.6
e	.050 BSC		1.27 BSC	
H	.394	.419	10.00	10.65
L	.016	.050	.40	1.27



CLARE

Worldwide Sales Offices

CLARE LOCATIONS

Clare Headquarters
78 Cherry Hill Drive
Beverly, MA 01915
Tel: 1-978-524-6700
Fax: 1-978-524-4900
Toll Free: 1-800-27-CLARE

Clare Switch Division
4315 N. Earth City Expressway
Earth City, MO 63045
Tel: 1-314-770-1832
Fax: 1-314-770-1812

Clare Micronix Division
145 Columbia
Aliso Viejo, CA 92656-1490
Tel: 1-949-831-4622
Fax: 1-949-831-4628

SALES OFFICES

AMERICAS

Americas Headquarters

Clare
78 Cherry Hill Drive
Beverly, MA 01915
Tel: 1-978-524-6700
Fax: 1-978-524-4900
Toll Free: 1-800-27-CLARE

Eastern Region

Clare
603 Apache Court
Mahwah, NJ 07430
Tel: 1-201-236-0101
Fax: 1-201-236-8685
Toll Free: 1-800-27-CLARE

Central Region

Clare Canada Ltd.
3425 Harvester Road, Suite 202
Burlington, Ontario L7N 3N1
Tel: 1-905-333-9066
Fax: 1-905-333-1824

Western Region

Clare
1852 West 11th Street, #348
Tracy, CA 95376
Tel: 1-209-832-4367
Fax: 1-209-832-4732
Toll Free: 1-800-27-CLARE

Canada

Clare Canada Ltd.
3425 Harvester Road, Suite 202
Burlington, Ontario L7N 3N1
Tel: 1-905-333-9066
Fax: 1-905-333-1824

EUROPE

European Headquarters

CP Clare nv
Bampslaan 17
B-3500 Hasselt (Belgium)
Tel: 32-11-300868
Fax: 32-11-300890

France

Clare France Sales
Lead Rep
99 route de Versailles
91160 Champlan
France
Tel: 33 1 69 79 93 50
Fax: 33 1 69 79 93 59

Germany

Clare Germany Sales
ActiveComp Electronic GmbH
Mitterstrasse 12
85077 Manching
Germany
Tel: 49 8459 3214 10
Fax: 49 8459 3214 29

Italy

C.L.A.R.E.s.a.s.
Via C. Colombo 10/A
I-20066 Melzo (Milano)
Tel: 39-02-95737160
Fax: 39-02-95738829

Sweden

Clare Sales
Comptronic AB
Box 167
S-16329 Spånga
Tel: 46-862-10370
Fax: 46-862-10371

United Kingdom

Clare UK Sales
Marco Polo House
Cook Way
Bindon Road
Taunton
UK-Somerset TA2 6BG
Tel: 44-1-823 352541
Fax: 44-1-823 352797

ASIA/PACIFIC

Asian Headquarters

Clare
Room N1016, Chia-Hsin, Bldg II,
10F, No. 96, Sec. 2
Chung Shan North Road
Taipei, Taiwan R.O.C.
Tel: 886-2-2523-6368
Fax: 886-2-2523-6369

<http://www.clare.com>

Clare, Inc. makes no representations or warranties with respect to the accuracy or completeness of the contents of this publication and reserves the right to make changes to specifications and product descriptions at any time without notice. Neither circuit patent licenses nor indemnity are expressed or implied. Except as set forth in Clare's Standard Terms and Conditions of Sale, Clare, Inc. assumes no liability whatsoever, and disclaims any express or implied warranty, relating to its products including, but not limited to, the implied warranty of merchantability, fitness for a particular purpose, or infringement of any intellectual property right.

The products described in this document are not designed, intended, authorized or warranted for use as components in systems intended for surgical implant into the body, or in other applications intended to support or sustain life, or where malfunction of Clare's product may result in direct physical harm, injury, or death to a person or severe property or environmental damage. Clare, Inc. reserves the right to discontinue or make changes to its products at any time without notice.

Specification: DS-M980-02-R3
©Copyright 2001, Clare, Inc.
All rights reserved. Printed in USA.
7/20/01