



M22100

4 X 4 CROSSPOINT SWITCH WITH CONTROL MEMORY

- LOW ON RESISTANCE – 75 Ω TYP. AT $V_{DD} = 12\text{ V}$
- "BUILT-IN" CONTROL LATCHES
- LARGE ANALOG SIGNAL CAPABILITY $\pm V_{DD}/2$
- TRANSMITS SIGNALS UP TO 10 MHz
- MATCHED SWITCH CHARACTERISTICS
 $\Delta R_{ON} = 18\ \Omega$ TYP. AT $V_{DD} - V_{SS} = 12\text{ V}$.
- HIGH LINEARITY : - 0.5 % DISTORTION (typ.)
AT $f = 1\text{ KHz}$, $V_{IN} = 5\text{ V}$ PEAK TO PEAK, $V_{DD} - V_{SS} = 10\text{ V}$, $R_L = 10\text{ K}\Omega$
- STANDARD COS/MOS NOISE IMMUNITY
- 100 % TESTED FOR QUIESCENT CURRENT

Therefore, all switches must be turned off by putting the strobe high and data-in-low, and then addressing all switches in succession.

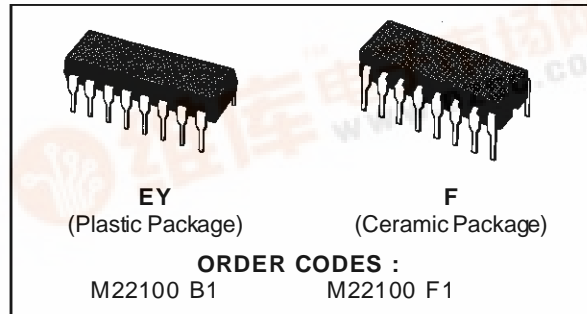

DESCRIPTION

The M22100 combines a 4 x 4 array of crosspoints (transmission gates) with a 4-line-to-16-line decoder and 16 latch circuits. Any one of the sixteen transmission gates (crosspoints) can be selected by applying the appropriate four line address. The selected transmission gate can be turned on or off by applying a logical one or zero, respectively, to the data input and strobing the strobe input to a logical one. Any number of the transmission gates can be ON simultaneously.

When the required operating power is applied to the M22100, the states of the 16 switches are indeterminate.

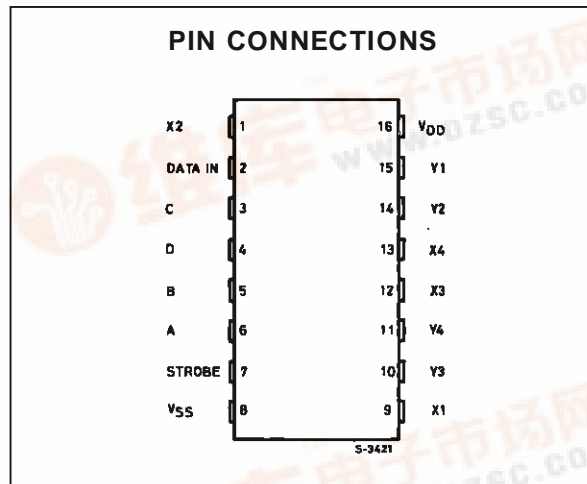

FUNCTIONAL DIAGRAM

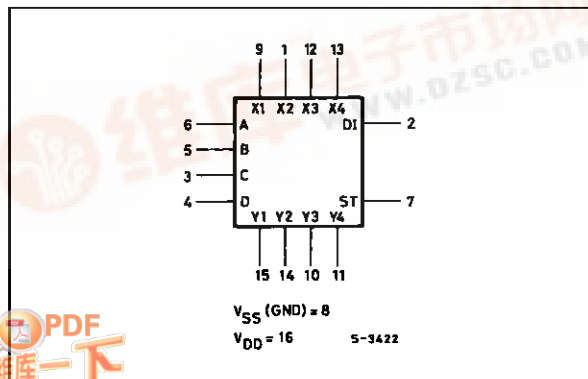

TRUTH TABLE

Address				Select	Address				Select		
A	B	C	D		A	B	C	D			
0	0	0	0	X1	Y1	0	0	0	1	X1	Y3
1	0	0	0	X2	Y1	1	0	0	1	X2	Y3
0	1	0	0	X3	Y1	0	1	0	1	X3	Y3
1	1	0	0	X4	Y1	1	1	0	1	X4	Y3
0	0	1	0	X1	Y2	0	0	1	1	X1	Y4
1	0	1	0	X2	Y2	1	0	1	1	X2	Y4
0	1	1	0	X3	Y2	0	1	1	1	X3	Y4
1	1	1	0	X4	Y2	1	1	1	1	X4	Y4



M22100

ABSOLUTE MAXIMUM RATING

Symbol	Parameter	Value	Unit
V _{DD} *	Supply Voltage: Ceramic Types Plastic Types	-0.5 to +20	V
		-0.5 to +18	V
V _i	Input Voltage	-0.5 to V _{DD} + 0.5	V
I _i	DC Input Current (any one input)	± 10	mA
P _{tot}	Total Power Dissipation (per package) Dissipation per Output Transistor for Top = Full Package Temperature Range	200	mW
		100	mW
T _{op}	Operating Temperature: Ceramic Types Plastic Types	-55 to +125	°C
		-40 to +85	°C
T _{stg}	Storage Temperature	-65 to +150	°C

Stresses above those listed under "Absolute Maximum Ratings" may cause permanent damage to the device. This is a stress rating only and functional operation of the device at these or any other conditions above those indicated in the operational sections of this specification is not implied. Exposure to absolute maximum rating conditions for external periods may affect device reliability.

* All voltage values are referred to V_{SS} pin voltage.

RECOMMENDED OPERATING CONDITIONS

Symbol	Parameter	Value	Unit
V _{DD}	Supply Voltage: Ceramic Types Plastic Types	3 to 18	V
		3 to 15	V
V _i	Input Voltage	0 to V _{DD}	V
T _{op}	Operating Temperature: Ceramic Types Plastic Types	-55 to +125	°C
		-40 to +85	°C

LOGIC DIAGRAM

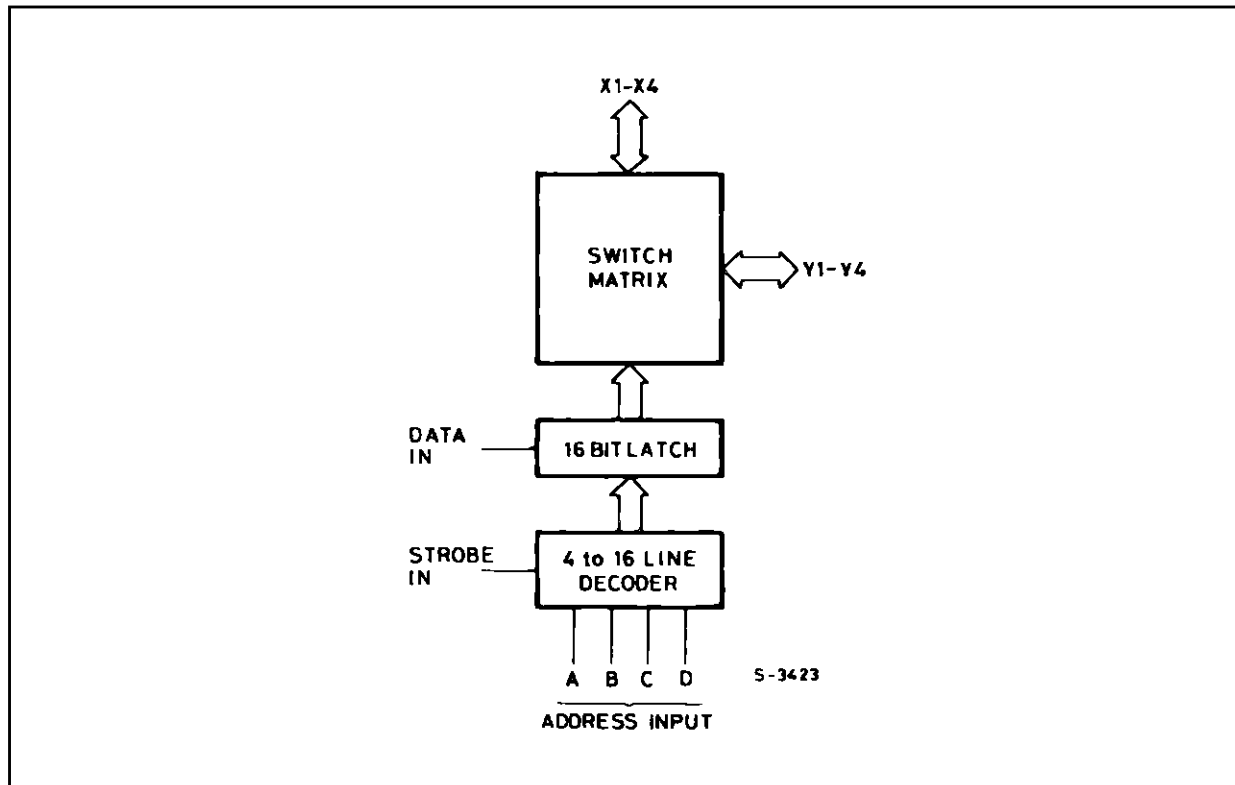

STATIC ELECTRICAL CHARACTERISTICS (over recommended operating conditions)

Symbol	Parameter	Test Conditions				Value						Unit				
			V _I (V)	V _{DD} (V)	T _{LOW} *		25 °C			T _{HIGH} *						
					Min.	Max.	Min.	Typ.	Max.	Min.	Max.					
CROSSPOINT																
I _L	Quiescent Supply Current	F1		5				0.04	5		150	μA				
				10				0.04	10		300					
				15				0.04	20		600					
				20				0.08	100		3000					
		B1		5				0.04	20		150					
				10				0.04	40		300					
R _{ON}	On Resistance	F1	Any Switch	5		450		225	1250		1625	Ω				
				10		135		85	180		230					
				12		100		75	135		175					
				15		70		65	95		125					
		B1	V _{IS} = 0 to V _{DD}	5		1000		225	1250		1440					
				10		145		85	180		205					
				12		110		75	135		155					
				15		75		65	95		110					
				ΔON	Resistance ΔR _{ON} (Between any two channels)			5					35			Ω
								10					20			
OFF Channel Leakage Current		F1	All Switch OFF	0/18	18		±0.1		±10 ⁻³	±0.1•		±1	μA			
				0/15	15		±0.3		±10 ⁻³	±0.3		±1				
		B1		0/18	18		±0.1		±10 ⁻³	±0.1•		±1				
				0/15	15		±0.3		±10 ⁻³	±0.3		±1				
CONTROL																
V _{IL}	Input Low Voltage		OFF Switch I _L < 0.2 μA	5		1.5			1.5		1.5	V				
				10		3			3		3					
				15		4			4		4					
V _{IH}	Input High Voltage		ON Switch see R _{ON} Characteristics	5	3.5		3.5				3.5	V				
				10	7		7			7						
				15	11		11			11						
I _I	Input Current	F1	Any Control Input	0/18	18		±0.1		±10 ⁻⁵	±0.1•		±1	μA			
		B1		0/15	15		±0.3		±10 ⁻⁵	±0.3		±1				
C _I	Input Capacitance		Any Input					5	7.5			pF				

• Determined by minimum feasible leakage measurement for automatic testing

* T_{LOW} = -55 °C for **HCC** device; -40 °C for **HCF** device.

* T_{HIGH} = +125 °C for **HCC** device; +85 °C for **HCF** device.

The Noise Margin for both "1" and "0" level is: 1V min. with V_{DD} = 5V, 2V min. with V_{DD} = 10V, 2.5V min. with V_{DD} = 15V

M22100

DYNAMIC ELECTRICAL CHARACTERISTICS ($T_{amb} = 25\text{ }^{\circ}\text{C}$, $C_L = 50\text{ pF}$, all input rise and fall times = 20 ns)

Symbol	Parameter	Test Conditions				Value			Unit
		f_i (KHz)	R_L (KW)	$V_{IS} \bullet$ (V)	V_{DD} (V)	Min.	Typ.	Max.	
CROSSPOINT									
t_{PHL} t_{PLH}	Propagation Delay Time Address or Strobe Inputs to Output		10	5 10 15	5 10 15		30 15 10	60 30 20	ns
	Frequency Response (Any Switch ON)		1	1	5	10		40	MHz
	Sine Wave Distortion		1	1	5	10		0.5	%
	Feedthrough (All Switches OFF)		1.6	1	5	10		80	dB
	Frequency for Signal Crosstalk Attenuation of 40 dB			1	10	10		1.5	MHz
	Frequency for Signal Crosstalk Attenuation of 110 dB			1	10	10		0.1	KHz
C	Capacitance Xn to Ground Yn to Ground Feedthrough					5-15		18 30 0.4	pF
CONTROLS									
t_{PHZ}	Propagation Delay Time Strobe to Output (Switch Turn-ON to High Level)	$R_L = 1\text{ K}\Omega$ $C_L = 50\text{ pF}$ $t_r, t_f = 20\text{ ns}$	See Figure 1	5		500	1000	ns	
				10		230	460		
				15		145	290		
t_{PZH}	Propagation Delay Time Data-In to Output (Switch Turn-ON to High Level)		See Figure 2	5		500	1000	ns	
				10		220	440		
				15		135	270		
t_{PZH}	Propagation Delay Time Address to Output (Switch Turn-ON to High Level)		See Figure 3	5		480	960	ns	
				10		225	450		
				15		150	300		
t_{PHZ}	Propagation Delay Time Strobe to Output (Switch Turn-OFF)		See Figure 1	5		450	900	ns	
				10		200	400		
				15		165	330		
t_{PZL}	Propagation Delay Time Data-In to Output (Switch Turn-ON to Low Level)		See Figure 2	5		500	1000	ns	
				10		220	440		
		15			135	270			
t_{PHZ}	Propagation Delay Time Address to Output (Switch Turn-OFF)	See Figure 3	5		425	850	ns		
			10		190	380			
			15		145	290			
t_{setup}	Setup Time Data-In to Strobe, Address		5		200	400	ns		
			10		80	160			
			15		50	100			

• Peak to peak voltage symmetrical about $V_{DD}/2$

DYNAMIC ELECTRICAL CHARACTERISTICS (continued)

Symbol	Parameter	Test Conditions				Value			Unit
		f_i (KHz)	R_L (K Ω)	V_{IS} • (V)	V_{DD} (V)	Min.	Typ.	Max.	
CONTROLS (continued)									
t_{hold}	Hold Time Data-In to Strobe, Address	$R_L = 1\text{ K}\Omega$ $C_L = 50\text{ pF}$ $t_r, t_f = 20\text{ ns}$			5		180		ns
					10		110		
					15		35		
$f\phi$	Switching Frequency				5	0.6	1.2		MHz
					10	1.6	3.2		
					15	2.5	5		
t_w	Strobe Pulse Width				5		300	600	ns
					10		120	240	
					15		90	180	
	Control Crosstalk Data-In, Address, or Strobe to Output			10	10	10		75	mV (peak)

• Peak to peak voltage symmetrical about $V_{DD}/2$

Typical ON Resistance vs. Input Signal Voltage at $V_{DD} = -V_{SS} = 2.5\text{ V}$.

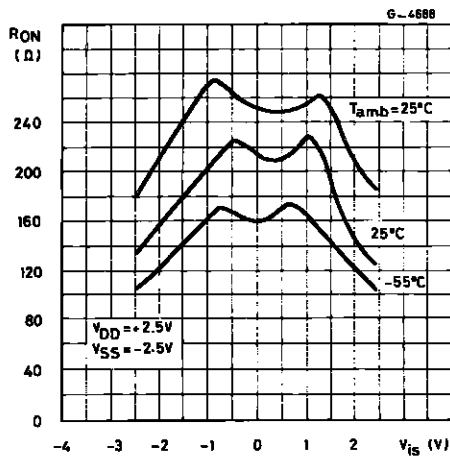

Typical ON Resistance vs. Input Signal Voltage at $V_{DD} = -V_{SS} = 5\text{ V}$.

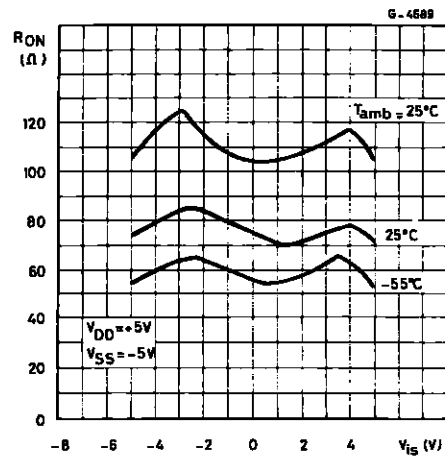

M22100

Typical ON Resistance vs. Input Signal Voltage at $V_{DD} = -V_{SS} = 7.5\text{ V}$.

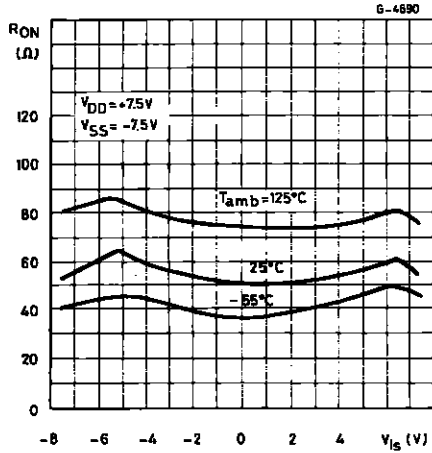

Typical ON Resistance vs.. Input Signal Voltage at $T_{amb} = 25^\circ\text{C}$.

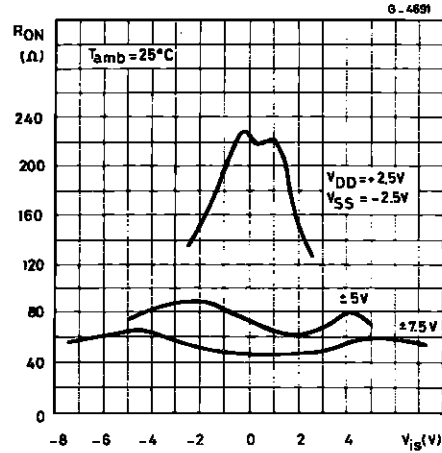

Typical Switch ON Transfer Characteristics (1 of 16 switches).

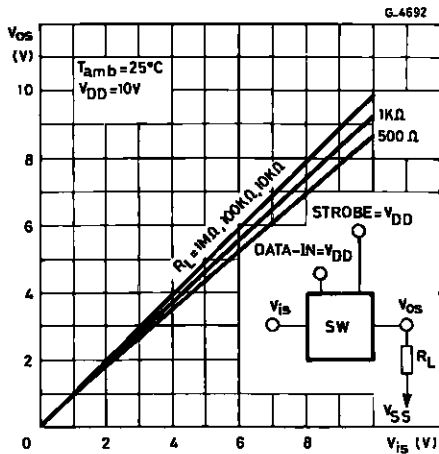

Typical Switch ON Frequency Response Characteristics.

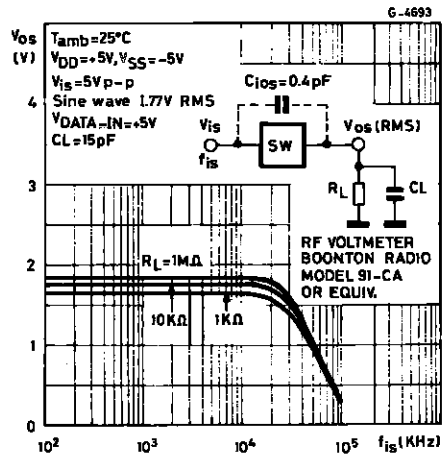

Typical Crosstalk Between switches vs. Signal Frequency.

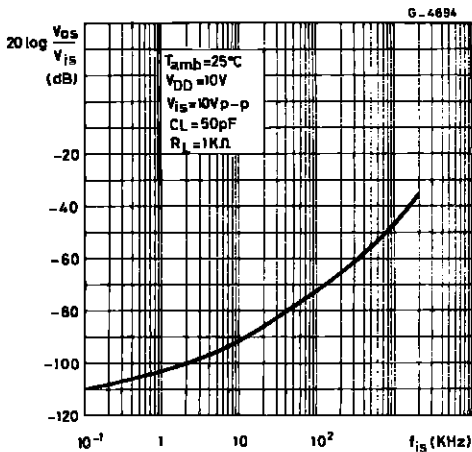

Typical Dynamic Power Dissipation vs. Switching Frequency.

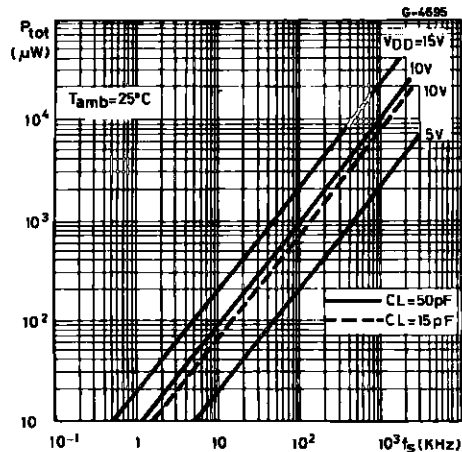

TEST CIRCUITS

Quiescent Current

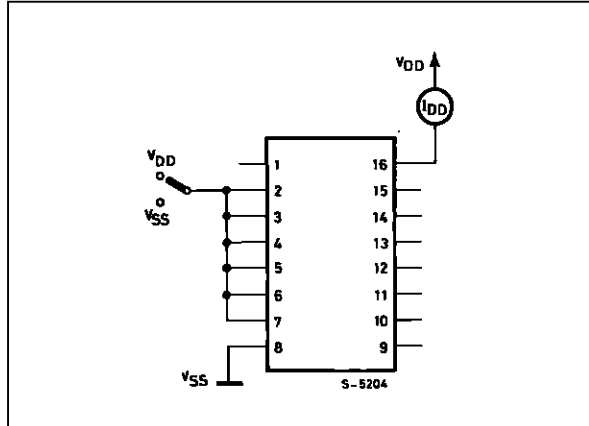

Input Current.

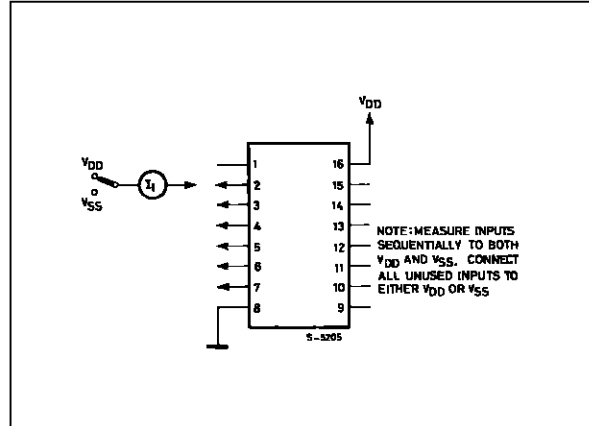

Off Switch Input or Output Leakage Current.

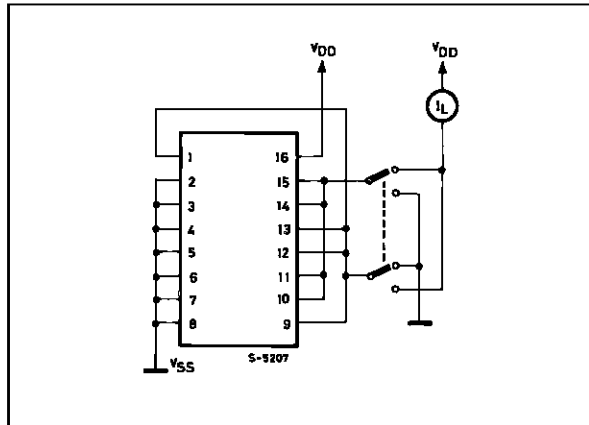

Dynamic Power Dissipation.

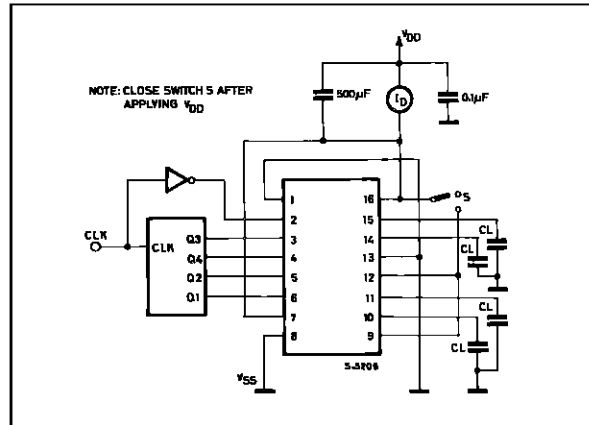

Crostalk Between Switch Circuits in the Same Package.

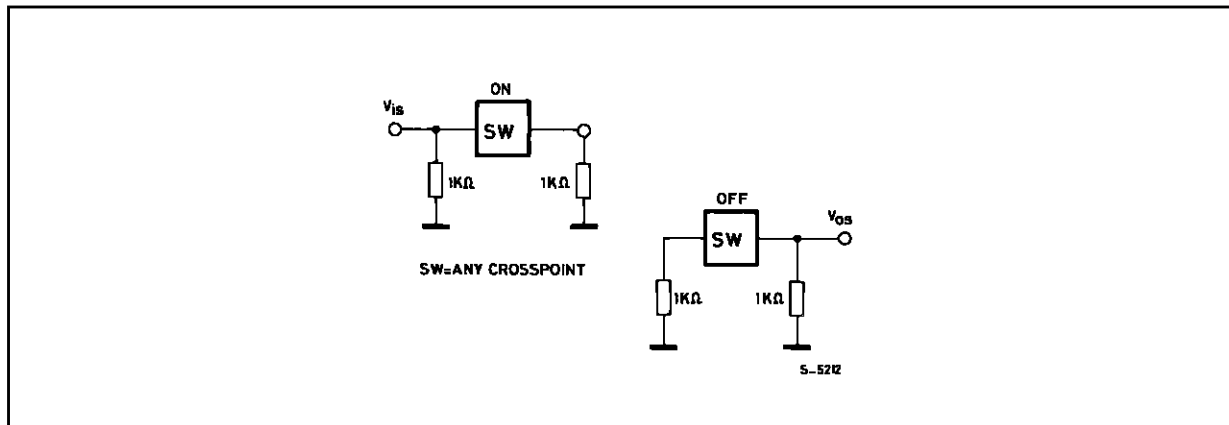

M22100

Propagation Delay Time and Waveforms (signal input to signal output, switch ON).

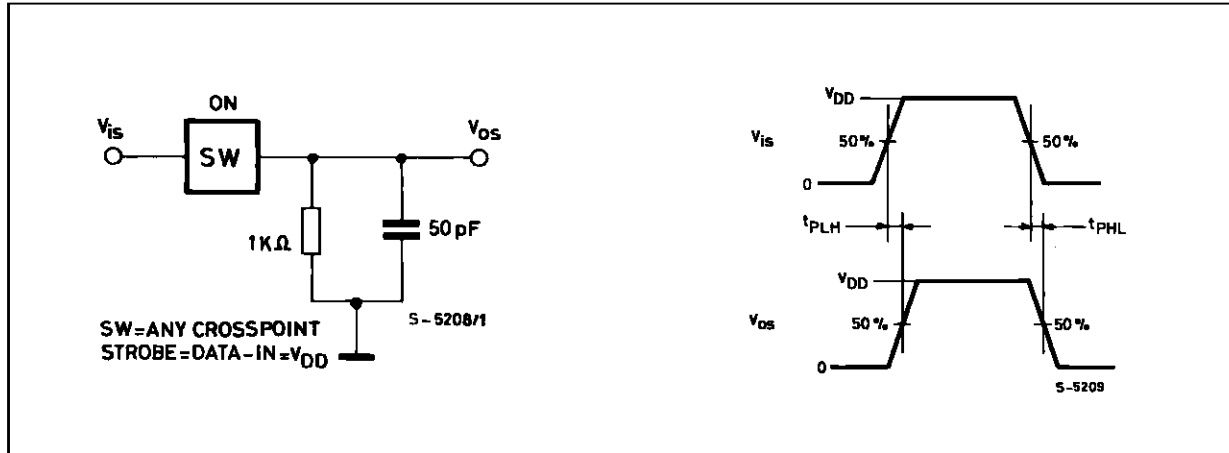

Waveforms for Crosstalk (control input to signal output).

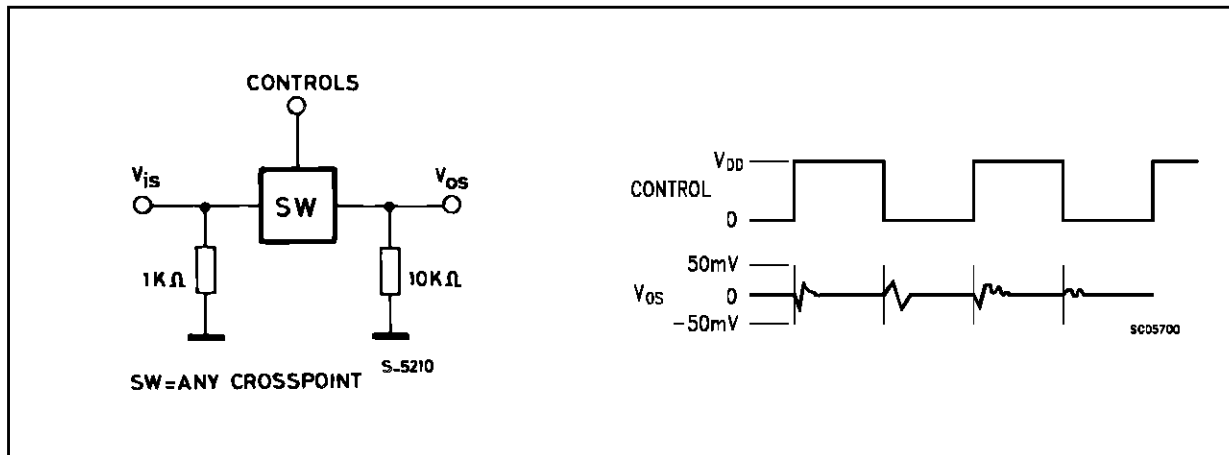

Figure 1 : Propagation Delay Time and Waveforms (strobe to signal output, switch Turn-ON or Turn-OFF).

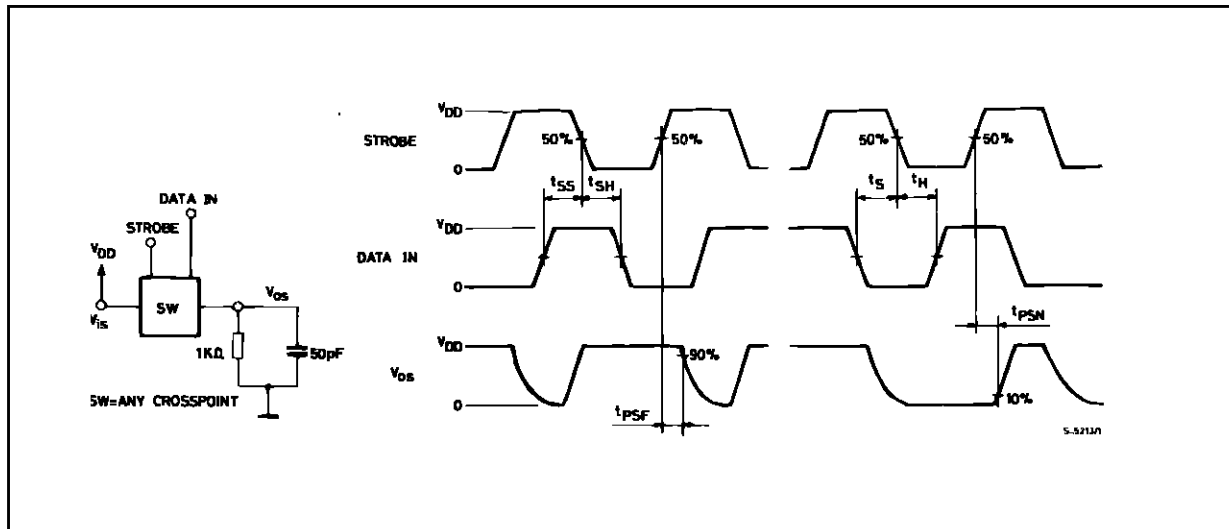

Figure 2 : Propagation Delay Time and Waveforms (data-in to signal output, switch Turn-ON to high or low level).

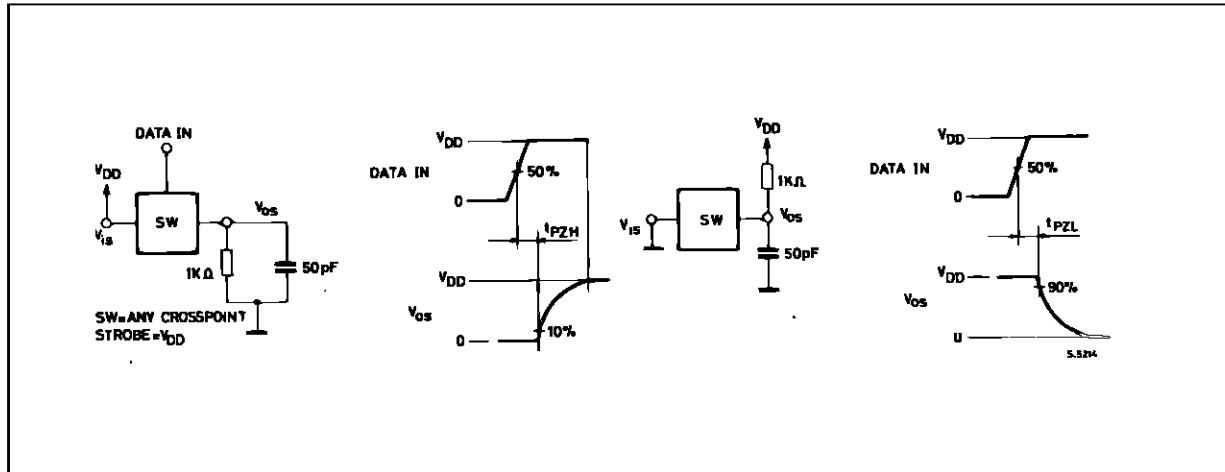
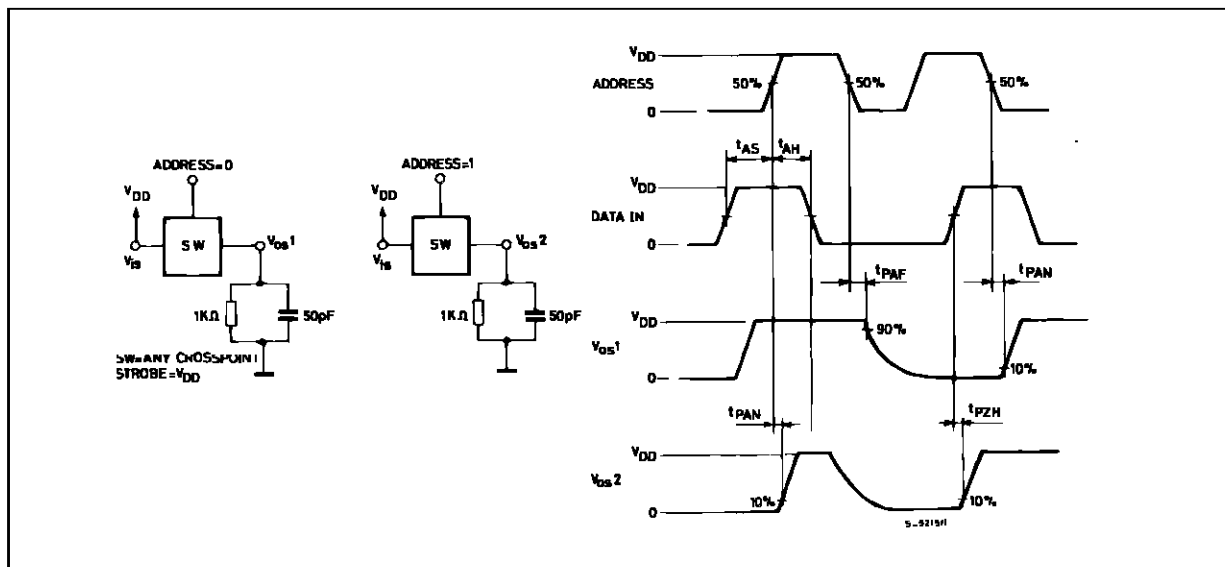

Figure 3 : Propagation Delay Time and Waveforms (address to signal output switch Turn-ON or Turn-OFF).



M22100

Plastic DIP16 (0.25) MECHANICAL DATA

DIM.	mm			inch		
	MIN.	TYP.	MAX.	MIN.	TYP.	MAX.
a1	0.51			0.020		
B	0.77		1.65	0.030		0.065
b		0.5			0.020	
b1		0.25			0.010	
D			20			0.787
E		8.5			0.335	
e		2.54			0.100	
e3		17.78			0.700	
F			7.1			0.280
I			5.1			0.201
L		3.3			0.130	
Z			1.27			0.050

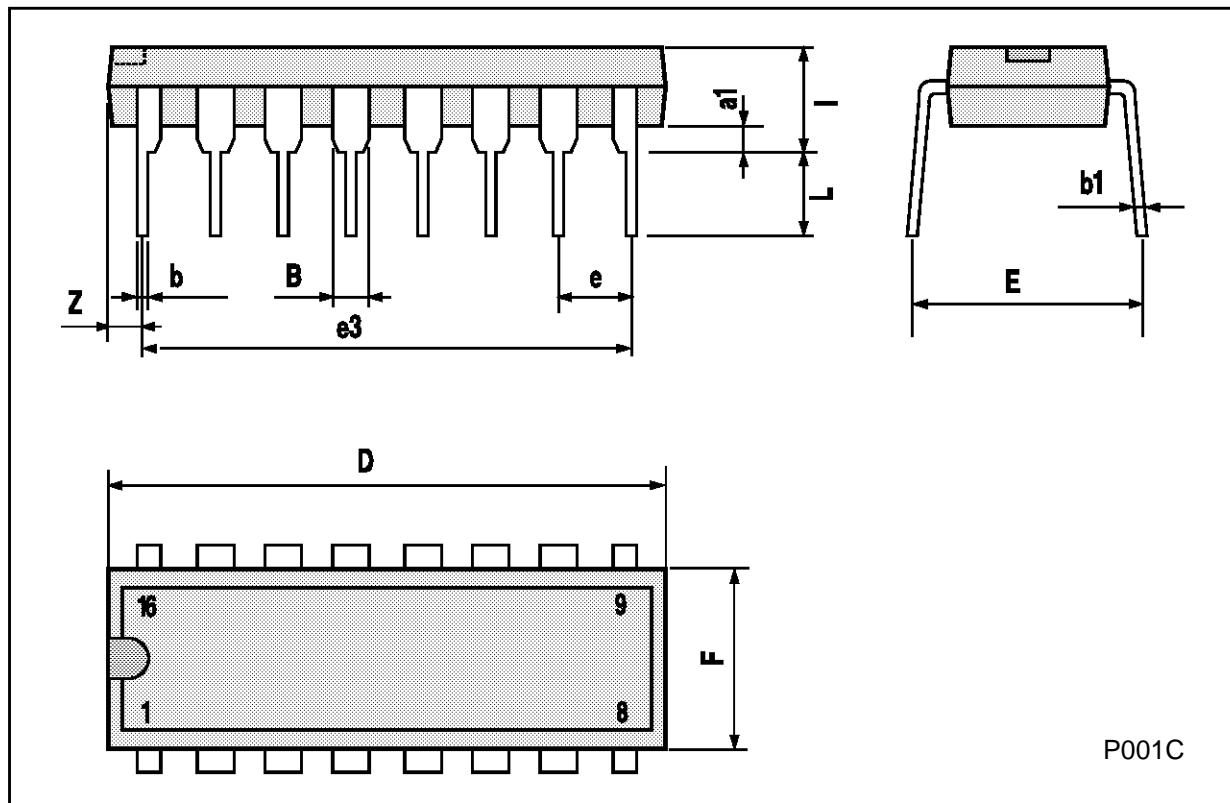

P001C

Ceramic DIP16/1 MECHANICAL DATA

DIM.	mm			inch		
	MIN.	TYP.	MAX.	MIN.	TYP.	MAX.
A			20			0.787
B			7			0.276
D		3.3			0.130	
E	0.38			0.015		
e3		17.78			0.700	
F	2.29		2.79	0.090		0.110
G	0.4		0.55	0.016		0.022
H	1.17		1.52	0.046		0.060
L	0.22		0.31	0.009		0.012
M	0.51		1.27	0.020		0.050
N			10.3			0.406
P	7.8		8.05	0.307		0.317
Q			5.08			0.200

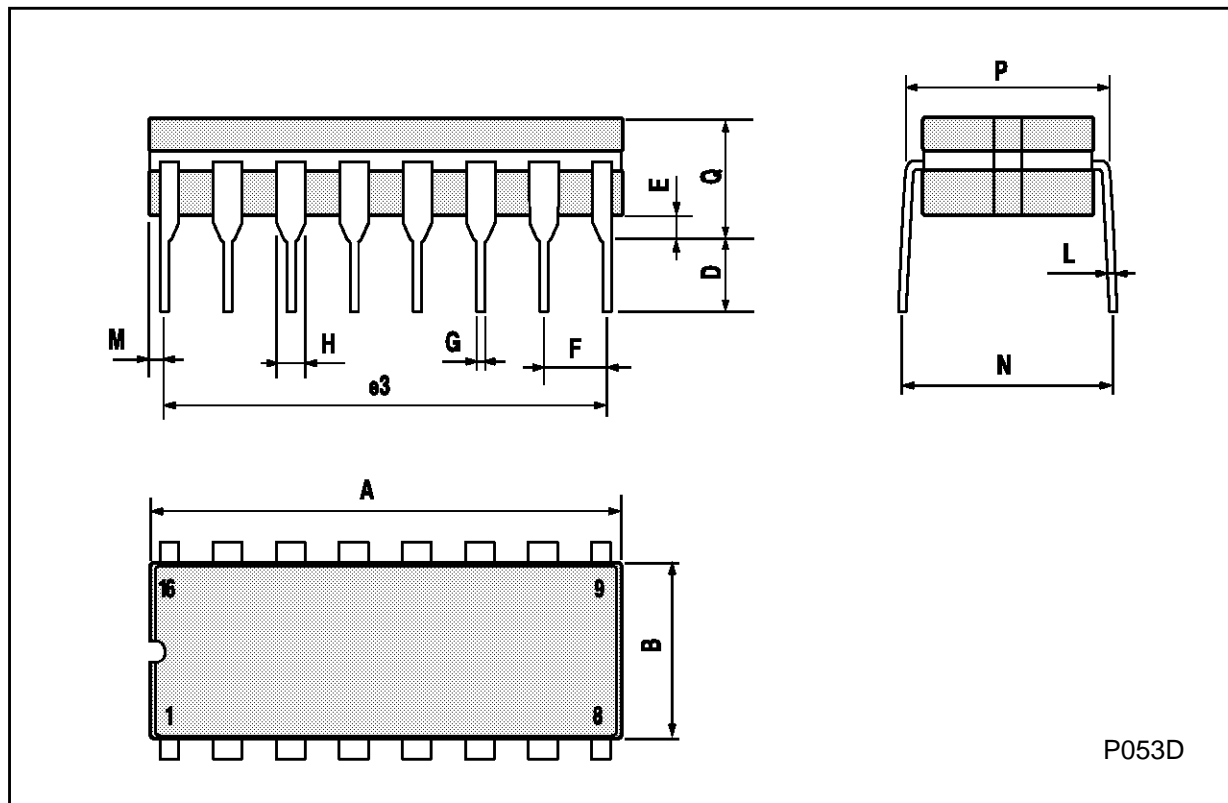

M22100

PLCC20 MECHANICAL DATA

DIM.	mm			inch		
	MIN.	TYP.	MAX.	MIN.	TYP.	MAX.
A	9.78		10.03	0.385		0.395
B	8.89		9.04	0.350		0.356
D	4.2		4.57	0.165		0.180
d1		2.54			0.100	
d2		0.56			0.022	
E	7.37		8.38	0.290		0.330
e		1.27			0.050	
e3		5.08			0.200	
F		0.38			0.015	
G			0.101			0.004
M		1.27			0.050	
M1		1.14			0.045	

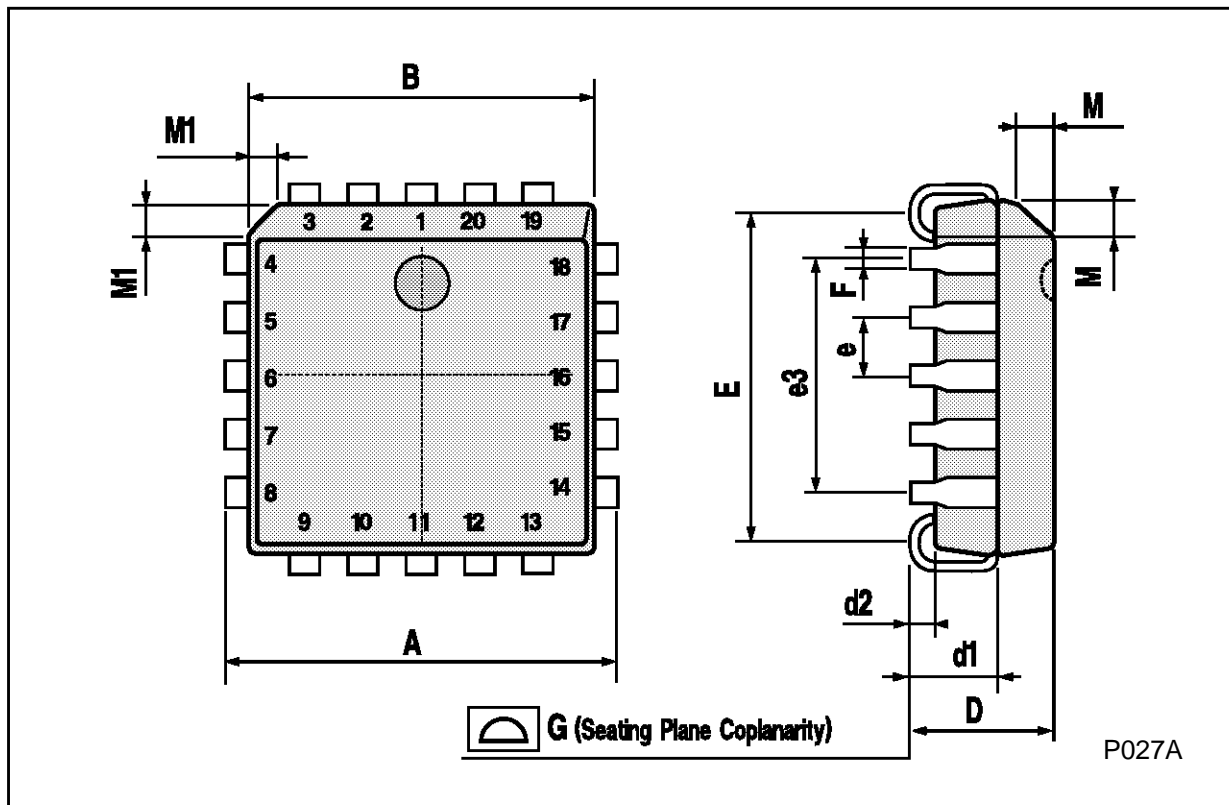

P027A

Information furnished is believed to be accurate and reliable. However, SGS-THOMSON Microelectronics assumes no responsibility for the consequences of use of such information nor for any infringement of patents or other rights of third parties which may result from its use. No license is granted by implication or otherwise under any patent or patent rights of SGS-THOMSON Microelectronics. Specifications mentioned in this publication are subject to change without notice. This publication supersedes and replaces all information previously supplied. SGS-THOMSON Microelectronics products are not authorized for use as critical components in life support devices or systems without express written approval of SGS-THOMSON Microelectronics.

© 1994 SGS-THOMSON Microelectronics - All Rights Reserved

SGS-THOMSON Microelectronics GROUP OF COMPANIES
Australia - Brazil - France - Germany - Hong Kong - Italy - Japan - Korea - Malaysia - Malta - Morocco - The Netherlands -
Singapore - Spain - Sweden - Switzerland - Taiwan - Thailand - United Kingdom - U.S.A