



M28C17

16K (2K x 8) PARALLEL EEPROM with SOFTWARE DATA PROTECTION

NOT FOR NEW DESIGN

- FAST ACCESS TIME: 90ns
- SINGLE 5V ± 10% SUPPLY VOLTAGE
- LOW POWER CONSUMPTION
- FAST WRITE CYCLE:
 - 64 Bytes Page Write Operation
 - Byte or Page Write Cycle: 3ms Max
- ENHANCED END OF WRITE DETECTION:
 - Ready/Busy Open Drain Output
 - Data Polling
 - Toggle Bit
- PAGE LOAD TIMER STATUS BIT
- HIGH RELIABILITY SINGLE POLYSILICON, CMOS TECHNOLOGY:
 - Endurance >100,000 Erase/Write Cycles
 - Data Retention >40 Years
- JEDEC APPROVED BYTEWISE PIN OUT
- SOFTWARE DATA PROTECTION
- **M28C17 is replaced by the products described on the document M28C16A**

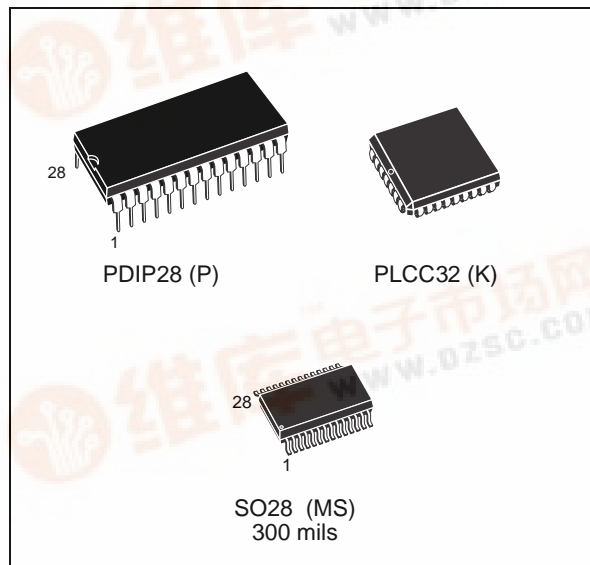

DESCRIPTION

The M28C17 is a 2K x 8 low power Parallel EEPROM fabricated with SGS-THOMSON proprietary single polysilicon CMOS technology. The device offers fast access time with low power dissipation and requires a 5V power supply.

The M28C17 offers the same features than the M28C16, in addition to the Ready/Busy pin.

The circuit has been designed to offer a flexible microcontroller interface featuring both hardware

Figure 1. Logic Diagram

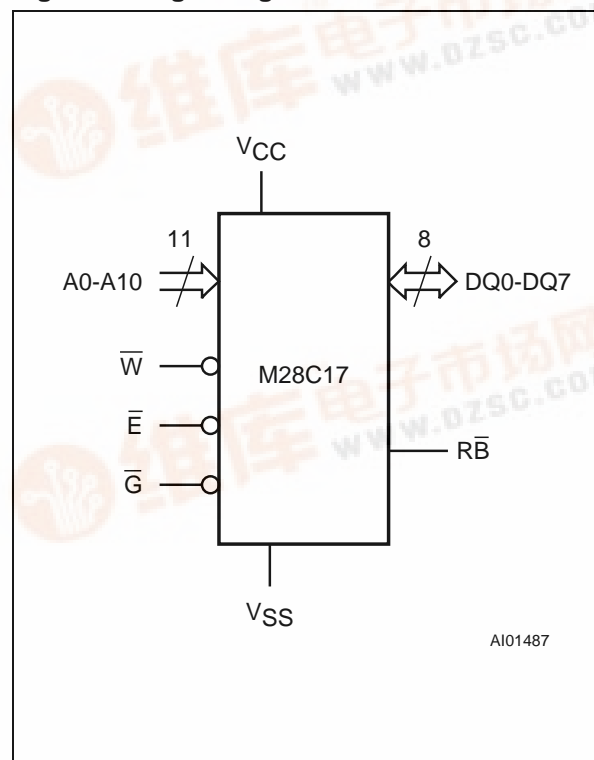

Table 1. Signal Names

| | |
|------------------|---------------------|
| A0 - A10 | Address Input |
| DQ0 - DQ7 | Data Input / Output |
| \bar{W} | Write Enable |
| \bar{E} | Chip Enable |
| \bar{G} | Output Enable |
| $\bar{R\bar{B}}$ | Ready / Busy |
| V _{CC} | Supply Voltage |
| V _{SS} | Ground |



M28C17

Figure 2A. DIP Pin Connections

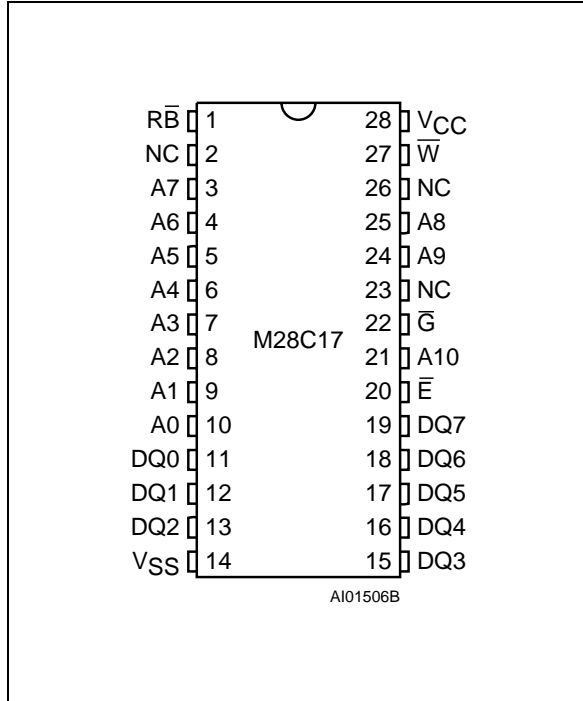

Warning: NC = Not Connected.

Figure 2B. LCC Pin Connections

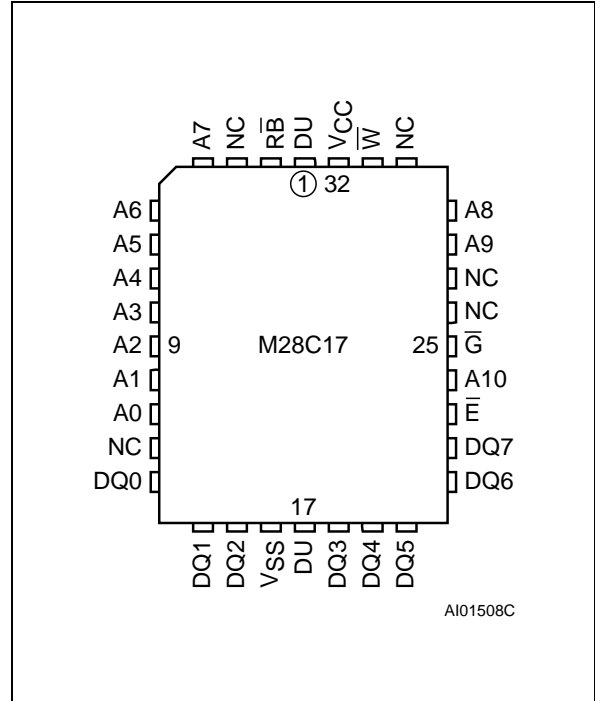

Warning: NC = Not Connected, DU = Don't Use.

Figure 2C. SO Pin Connections

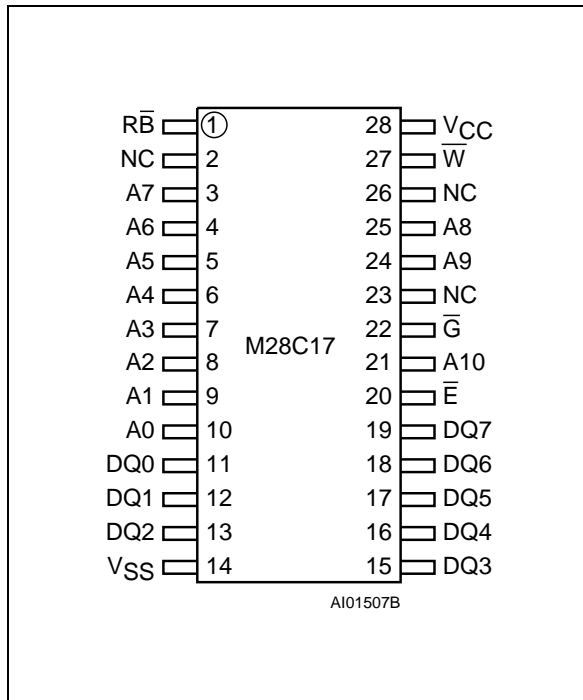

Warning: NC = Not Connected.

DESCRIPTION (cont'd)

and software handshaking with Ready/Busy, Data Polling and Toggle Bit. The M28C17 supports 64 byte page write operation. A Software Data Protection (SDP) is also possible using the standard JEDEC algorithm.

PIN DESCRIPTION

Addresses (A0-A10). The address inputs select an 8-bit memory location during a read or write operation.

Chip Enable (\bar{E}). The chip enable input must be low to enable all read/write operations. When Chip Enable is high, power consumption is reduced.

Output Enable (\bar{G}). The Output Enable input controls the data output buffers and is used to initiate read operations.

Data In/ Out (DQ0 - DQ7). Data is written to or read from the M28C17 through the I/O pins.

Write Enable (\bar{W}). The Write Enable input controls the writing of data to the M28C17.

Ready/Busy (\bar{RB}). Ready/Busy is an open drain output that can be used to detect the end of the internal write cycle.

Table 2. Absolute Maximum Ratings ⁽¹⁾

| Symbol | Parameter | Value | Unit |
|------------------|---|-------------------------------|------|
| T _A | Ambient Operating Temperature | - 40 to 125 | °C |
| T _{STG} | Storage Temperature Range | - 65 to 150 | °C |
| V _{CC} | Supply Voltage | - 0.3 to 6.5 | V |
| V _{IO} | Input/Output Voltage | - 0.3 to V _{CC} +0.6 | V |
| V _I | Input Voltage | - 0.3 to 6.5 | V |
| V _{ESD} | Electrostatic Discharge Voltage (Human Body model) ⁽²⁾ | 4000 | V |

Note: 1. Except for the rating "Operating Temperature Range", stresses above those listed in the Table "Absolute Maximum Ratings" may cause permanent damage to the device. These are stress ratings only and operation of the device at these or any other conditions above those indicated in the Operating sections of this specification is not implied. Exposure to Absolute Maximum Rating conditions for extended periods may affect device reliability. Refer also to the SGS-THOMSON SURE Program and other relevant quality documents.

2. 100pF through 1500Ω; MIL-STD-883C, 3015.7

Table 3. Operating Modes ⁽¹⁾

| Mode | \bar{E} | \bar{G} | \bar{W} | DQ0 - DQ7 |
|----------------|-----------|-----------|-----------|-----------|
| Standby | 1 | X | X | Hi-Z |
| Output Disable | X | 1 | X | Hi-Z |
| Write Disable | X | X | 1 | Hi-Z |
| Read | 0 | 0 | 1 | Data Out |
| Write | 0 | 1 | 0 | Data In |
| Chip Erase | 0 | V | 0 | Hi-Z |

Note: 1. 0 = V_{IL}; 1 = V_{IH}; X = V_{IL} or V_{IH}; V = 12 ± 5%.

OPERATION

In order to prevent data corruption and inadvertent write operations an internal V_{CC} comparator inhibits Write operation if V_{CC} is below V_{WI} (see Table 7). Access to the memory in write mode is allowed after a power-up as specified in Table 7.

Read

The M28C17 is accessed like a static RAM. When \bar{E} and \bar{G} are low with \bar{W} high, the data addressed is presented on the I/O pins. The I/O pins are high impedance when either \bar{G} or \bar{E} is high.

Write

Write operations are initiated when both \bar{W} and \bar{E} are low and \bar{G} is high. The M28C17 supports both \bar{E} and \bar{W} controlled write cycles. The Address is latched by the falling edge of \bar{E} or \bar{W} which ever occurs last and the Data on the rising edge of \bar{E} or \bar{W} which ever occurs first. Once initiated the write operation is internally timed until completion.

Page Write

Page write allows up to 64 bytes to be consecutively latched into the memory prior to initiating a programming cycle. All bytes must be located in a single page address, that is A6-A10 must be the same for all bytes. The page write can be initiated during any byte write operation.

Following the first byte write instruction the host may send another address and data with a minimum data transfer rate of 1/t_{WHWH} (see Figure 13). If a transition of \bar{E} or \bar{W} is not detected within t_{WHWH}, the internal programming cycle will start.

Chip Erase

The contents of the entire memory may be erased to FFh by use of the Chip Erase command by setting Chip Enable (\bar{E}) Low and Output Enable (\bar{G}) to V_{CC} + 7.0V. The chip is cleared when a 10ms low pulse is applied to the Write Enable pin.

Figure 3. Block Diagram

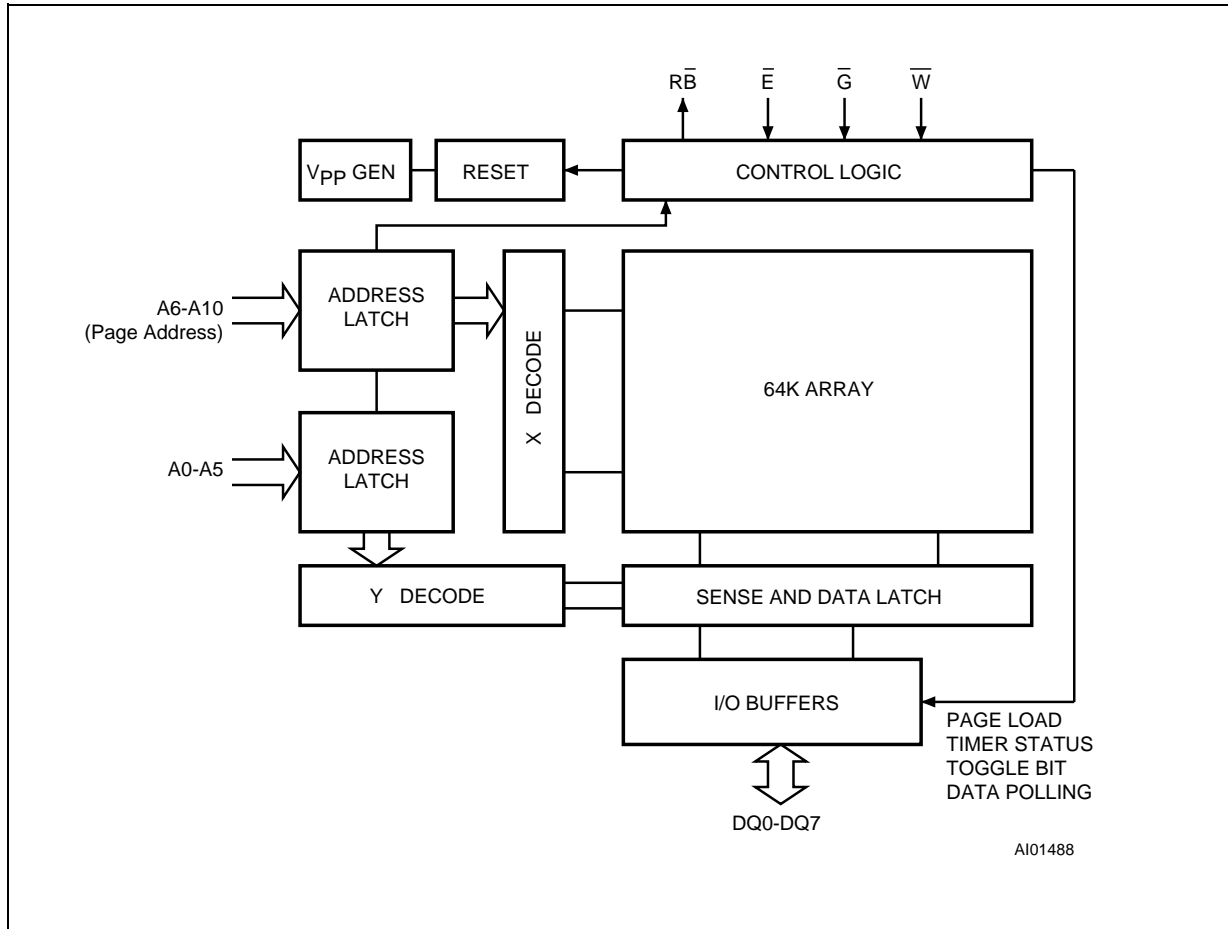

Microcontroller Control Interface

The M28C17 provides two write operation status bits and one status pin that can be used to minimize the system write cycle. These signals are available on the I/O port bits DQ7 or DQ6 of the memory during programming cycle only, or as the RB signal on a separate pin.

Figure 4. Status Bit Assignment

| DQ7 | DQ6 | DQ5 | DQ4 | DQ3 | DQ2 | DQ1 | DQ0 |
|-----|-----|------|------|------|------|------|------|
| DP | TB | PLTS | Hi-Z | Hi-Z | Hi-Z | Hi-Z | Hi-Z |

DP = Data Polling
 TB = Toggle Bit
 PLTS = Page Load Timer Status

Data Polling bit (DQ7). During the internal write cycle, any attempt to read the last byte written will produce on DQ7 the complementary value of the previously latched bit. Once the write cycle is finished the true logic value appears on DQ7 in the read cycle.

ished the true logic value appears on DQ7 in the read cycle.

Toggle bit (DQ6). The M28C17 offers another way for determining when the internal write cycle is completed. During the internal Erase/Write cycle, DQ6 will toggle from "0" to "1" and "1" to "0" (the first read value is "0") on subsequent attempts to read the memory. When the internal cycle is completed the toggling will stop and the device will be accessible for a new Read or Write operation.

Page Load Timer Status bit (DQ5). In the Page Write mode data may be latched by E or W. Up to 64 bytes may be input. The Data output (DQ5) indicates the status of the internal Page Load Timer. DQ5 may be read by asserting Output Enable Low (tPLTS). DQ5 Low indicates the timer is running, High indicates time-out after which the write cycle will start and no new data may be input.

Ready/Busy pin. The RB pin provides a signal at its open drain output which is low during the erase/write cycle, but which is released at the completion of the programming cycle.

Figure 5. Software Data Protection Enable Algorithm and Memory Write

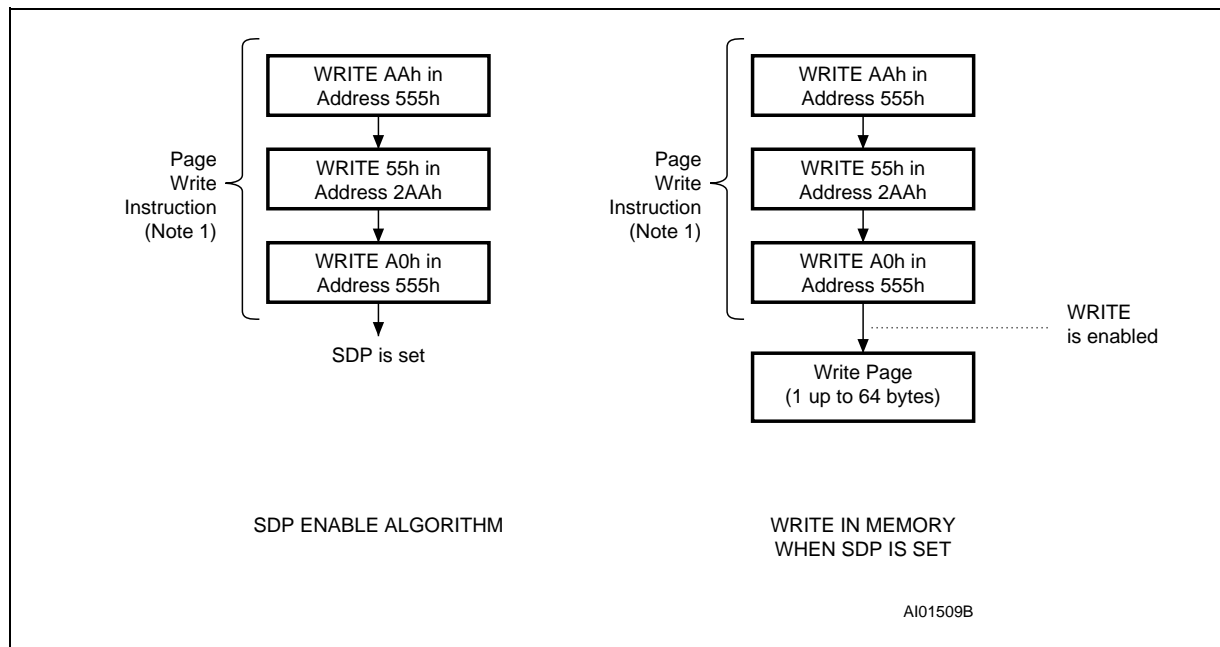

Note: 1. MSB Address bits (A6 to A10) differ during these specific Page Write operations.

Figure 6. Software Data Protection Disable Algorithm

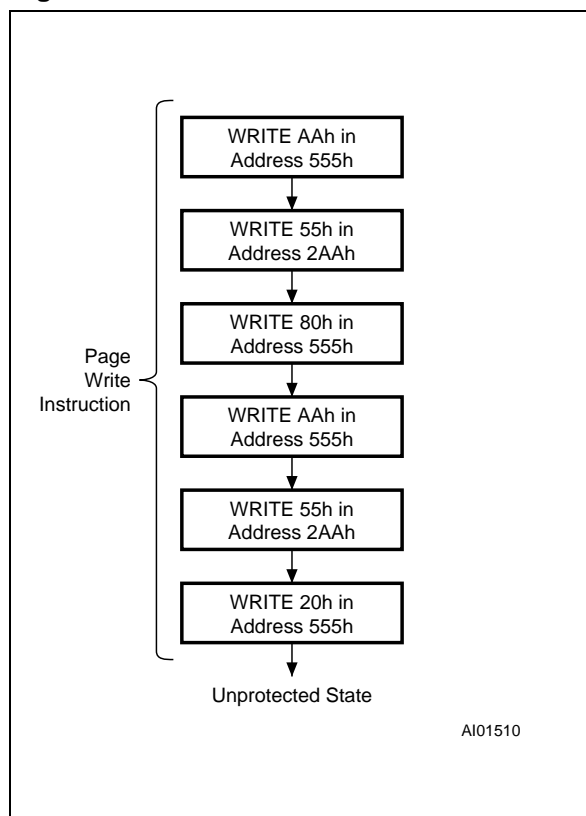

Software Data Protection

The M28C17 offers a software controlled write protection facility that allows the user to inhibit all write modes to the device including the Chip Erase instruction. This can be useful in protecting the memory from inadvertent write cycles that may occur due to uncontrolled bus conditions.

The M28C17 is shipped as standard in the "unprotected" state meaning that the memory contents can be changed as required by the user. After the Software Data Protection enable algorithm is issued, the device enters the "Protect Mode" of operation where no further write commands have any effect on the memory contents. The device remains in this mode until a valid Software Data Protection (SDP) disable sequence is received whereby the device reverts to its "unprotected" state. The Software Data Protection is fully non-volatile and is not changed by power on/off sequences.

To enable the Software Data Protection (SDP) the device requires the user to write (with a Page Write) three specific data bytes to three specific memory locations as per Figure 5. Similarly to disable the Software Data Protection the user has to write specific data bytes into six different locations as per Figure 6 (with a Page Write). This complex series ensures that the user will never enable or disable the Software Data Protection accidentally.

Table 4. AC Measurement Conditions

| | |
|---------------------------------------|--------------|
| Input Rise and Fall Times | ≤ 20ns |
| Input Pulse Voltages | 0.4V to 2.4V |
| Input and Output Timing Ref. Voltages | 0.8V to 2.0V |

Note that Output Hi-Z is defined as the point where data is no longer driven.

Figure 7. AC Testing Input Output Waveforms

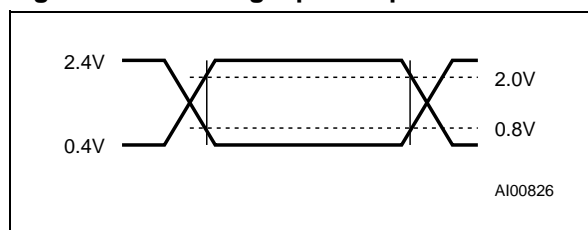

Figure 8. AC Testing Equivalent Load Circuit

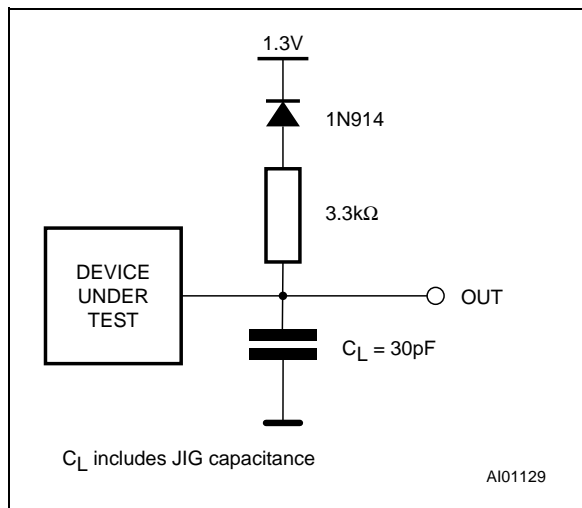

Table 5. Capacitance ⁽¹⁾ (T_A = 25 °C, f = 1 MHz)

| Symbol | Parameter | Test Condition | Min | Max | Unit |
|------------------|--------------------|-----------------------|-----|-----|------|
| C _{IN} | Input Capacitance | V _{IN} = 0V | | 6 | pF |
| C _{OUT} | Output Capacitance | V _{OUT} = 0V | | 12 | pF |

Note: 1. Sampled only, not 100% tested.

Table 6. Read Mode DC Characteristics

(T_A = 0 to 70°C or -40 to 85°C; V_{CC} = 4.5V to 5.5V)

| Symbol | Parameter | Test Condition | Min | Max | Unit |
|---------------------------------|-------------------------------|---|------|-----------------------|------|
| I _{LI} | Input Leakage Current | 0V ≤ V _{IN} ≤ V _{CC} | | 10 | μA |
| I _{LO} | Output Leakage Current | 0V ≤ V _{IN} ≤ V _{CC} | | 10 | μA |
| I _{CC} ⁽¹⁾ | Supply Current (TTL inputs) | $\bar{E} = V_{IL}, \bar{G} = V_{IL}, f = 5 \text{ MHz}$ | | 30 | mA |
| | Supply Current (CMOS inputs) | $\bar{E} = V_{IL}, \bar{G} = V_{IL}, f = 5 \text{ MHz}$ | | 25 | mA |
| I _{CC1} ⁽¹⁾ | Supply Current (Standby) TTL | $\bar{E} = V_{IH}$ | | 1 | mA |
| I _{CC2} ⁽¹⁾ | Supply Current (Standby) CMOS | $\bar{E} > V_{CC} - 0.3V$ | | 100 | μA |
| V _{IL} | Input Low Voltage | | -0.3 | 0.8 | V |
| V _{IH} | Input High Voltage | | 2 | V _{CC} + 0.5 | V |
| V _{OL} | Output Low Voltage | I _{OL} = 2.1 mA | | 0.4 | V |
| V _{OH} | Output High Voltage | I _{OH} = -400 μA | 2.4 | | V |

Note: 1. All I/O's open circuit.

Table 7. Power Up Timing ⁽¹⁾ (T_A = 0 to 70°C or -40 to 85°C)

| Symbol | Parameter | Min | Max | Unit |
|-----------------------------|---|-----|-----|------|
| t _{PUR} | Time Delay to Read Operation | 1 | | μs |
| t _{P_{UW}} | Time Delay to Write Operation (once V _{CC} ≥ 4.5V) | 10 | | ms |
| V _{WI} | Write Inhibit Threshold | 3.0 | 4.2 | V |

Note: 1. Sampled only, not 100% tested.

Table 8. Read Mode AC Characteristics(T_A = 0 to 70°C or -40 to 85°C; V_{CC} = 4.5V to 5.5V)

| Symbol | Alt | Parameter | Test Condition | M28C17 | | | | | | Unit |
|----------------------------------|------------------|---|--|--------|-----|------|-----|------|-----|------|
| | | | | -90 | | -120 | | -150 | | |
| | | | | min | max | min | max | min | max | |
| t _{AVQV} | t _{ACC} | Address Valid to Output Valid | $\bar{E} = V_{IL}$, $\bar{G} = V_{IL}$ | | 90 | | 120 | | 150 | ns |
| t _{ELQV} | t _{CE} | Chip Enable Low to Output Valid | $G = V_{IL}$ | | 90 | | 120 | | 150 | ns |
| t _{GLQV} | t _{OE} | Output Enable Low to Output Valid | $\bar{E} = V_{IL}$ | | 40 | | 45 | | 50 | ns |
| t _{EHQZ} ⁽¹⁾ | t _{DF} | Chip Enable High to Output Hi-Z | $\bar{G} = V_{IL}$ | 0 | 40 | 0 | 45 | 0 | 50 | ns |
| t _{GHQZ} ⁽¹⁾ | t _{DF} | Output Enable High to Output Hi-Z | $\bar{E} = V_{IL}$ | 0 | 40 | 0 | 45 | 0 | 50 | ns |
| t _{AXQX} | t _{OH} | Address Transition to Output Transition | $\bar{E} = V_{IL}$, $\bar{G} = V_{IL}$ | 0 | | 0 | | 0 | | ns |

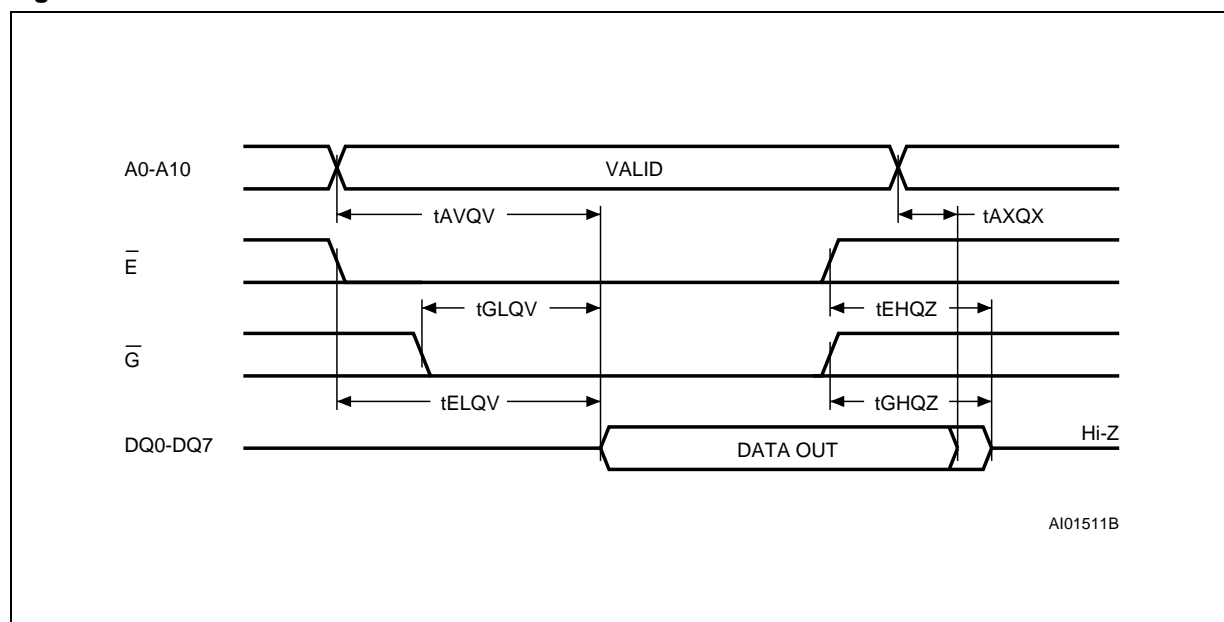
Note: 1. Output Hi-Z is defined as the point at which data is no longer driven.**Figure 9. Read Mode AC Waveforms****Note:** Write Enable (\bar{W}) = High

M28C17

Table 9. Write Mode AC Characteristics

($T_A = 0$ to 70°C or -40 to 85°C ; $V_{CC} = 4.5\text{V}$ to 5.5V)

| Symbol | Alt | Parameter | Test Condition | Min | Max | Unit |
|-------------|-----------|--|--------------------------------------|------|-----|---------------|
| t_{AVWL} | t_{AS} | Address Valid to Write Enable Low | $\bar{E} = V_{IL}, \bar{G} = V_{IH}$ | 0 | | ns |
| t_{AVEL} | t_{AS} | Address Valid to Chip Enable Low | $\bar{G} = V_{IH}, \bar{W} = V_{IL}$ | 0 | | ns |
| t_{ELWL} | t_{CES} | Chip Enable Low to Write Enable Low | $\bar{G} = V_{IH}$ | 0 | | ns |
| t_{GHWL} | t_{OES} | Output Enable High to Write Enable Low | $\bar{E} = V_{IL}$ | 0 | | ns |
| t_{GHEL} | t_{OES} | Output Enable High to Chip Enable Low | $\bar{W} = V_{IL}$ | 0 | | ns |
| t_{WLEL} | t_{WES} | Write Enable Low to Chip Enable Low | $\bar{G} = V_{IH}$ | 0 | | ns |
| t_{WLAX} | t_{AH} | Write Enable Low to Address Transition | | 50 | | ns |
| t_{ELAX} | t_{AH} | Chip Enable Low to Address Transition | | 50 | | ns |
| t_{WLDV} | t_{DV} | Write Enable Low to Input Valid | $\bar{E} = V_{IL}, \bar{G} = V_{IH}$ | | 1 | μs |
| t_{ELDV} | t_{DV} | Chip Enable Low to Input Valid | $\bar{G} = V_{IH}, \bar{W} = V_{IL}$ | | 1 | μs |
| t_{ELEH} | t_{WP} | Chip Enable Low to Chip Enable High | | 50 | | ns |
| t_{WHEH} | t_{CEH} | Write Enable High to Chip Enable High | | 0 | | ns |
| t_{WHGL} | t_{OEH} | Write Enable High to Output Enable Low | | 0 | | ns |
| t_{EHGL} | t_{OEH} | Chip Enable High to Output Enable Low | | 0 | | ns |
| t_{EHHW} | t_{WEH} | Chip Enable High to Write Enable High | | 0 | | ns |
| t_{WHDX} | t_{DH} | Write Enable High to Input Transition | | 0 | | ns |
| t_{EHDX} | t_{DH} | Chip Enable High to Input Transition | | 0 | | ns |
| t_{WHWL} | t_{WPH} | Write Enable High to Write Enable Low | | 50 | | ns |
| t_{WLWH1} | t_{WP} | Write Enable Low to Write Enable High | | 50 | | ns |
| t_{WHWH} | t_{BLC} | Byte Load Repeat Cycle Time | | 0.15 | 100 | μs |
| t_{WHRH} | t_{WC} | Write Cycle Time | | | 3 | ms |
| t_{WHRL} | t_{DB} | Write Enable High to Ready/Busy Low | Note 1 | | 150 | ns |
| t_{EHRL} | t_{DB} | Chip Enable High to Ready/Busy Low | Note 1 | | 150 | ns |
| t_{DVWH} | t_{DS} | Data Valid before Write Enable High | | 50 | | ns |
| t_{DVEH} | t_{DS} | Data Valid before Chip Enable High | | 50 | | ns |

Note: 1. With a 3.3 k Ω external pull-up resistor.

Figure 14. Data Polling Waveform Sequence

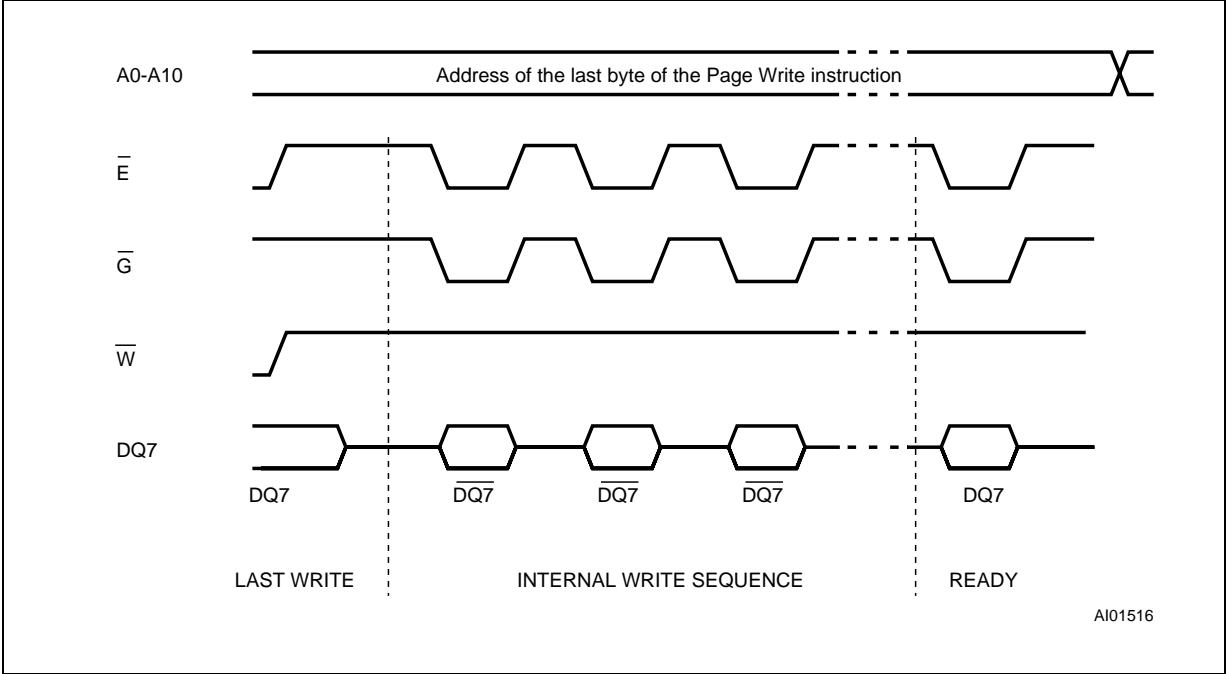
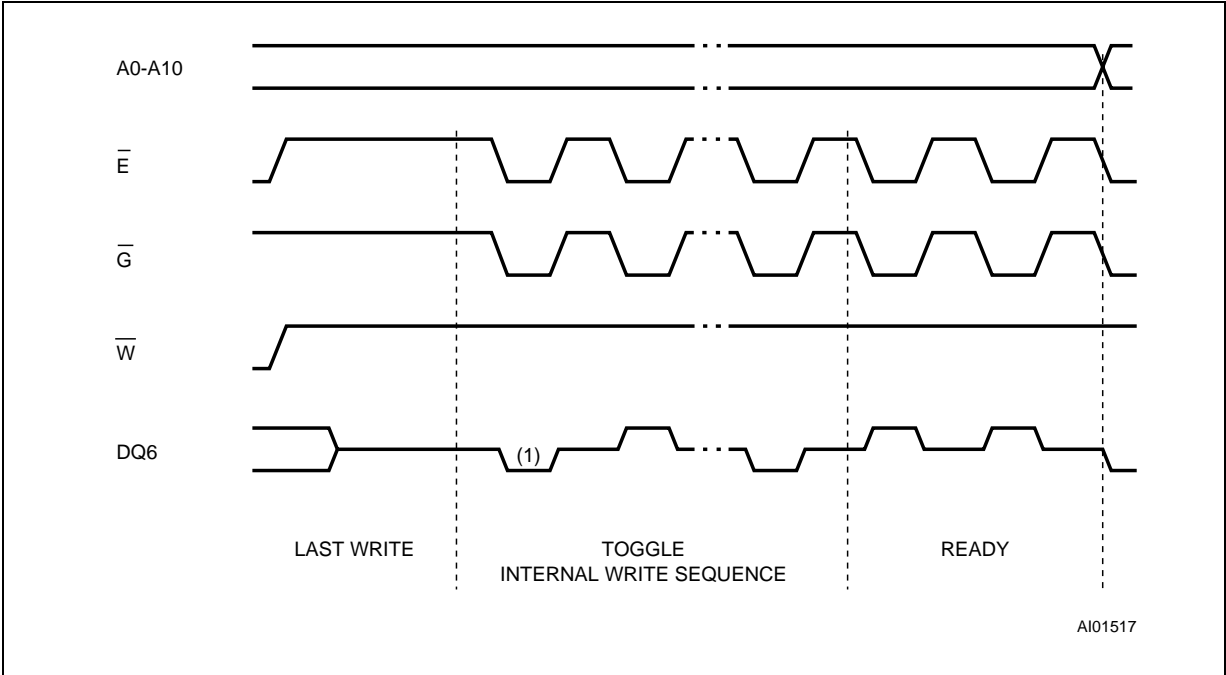

Figure 15. Toggle Bit Waveform Sequence



Note: 1. First Toggle bit is forced to '0'.

Figure 16. Chip Erase Waveforms

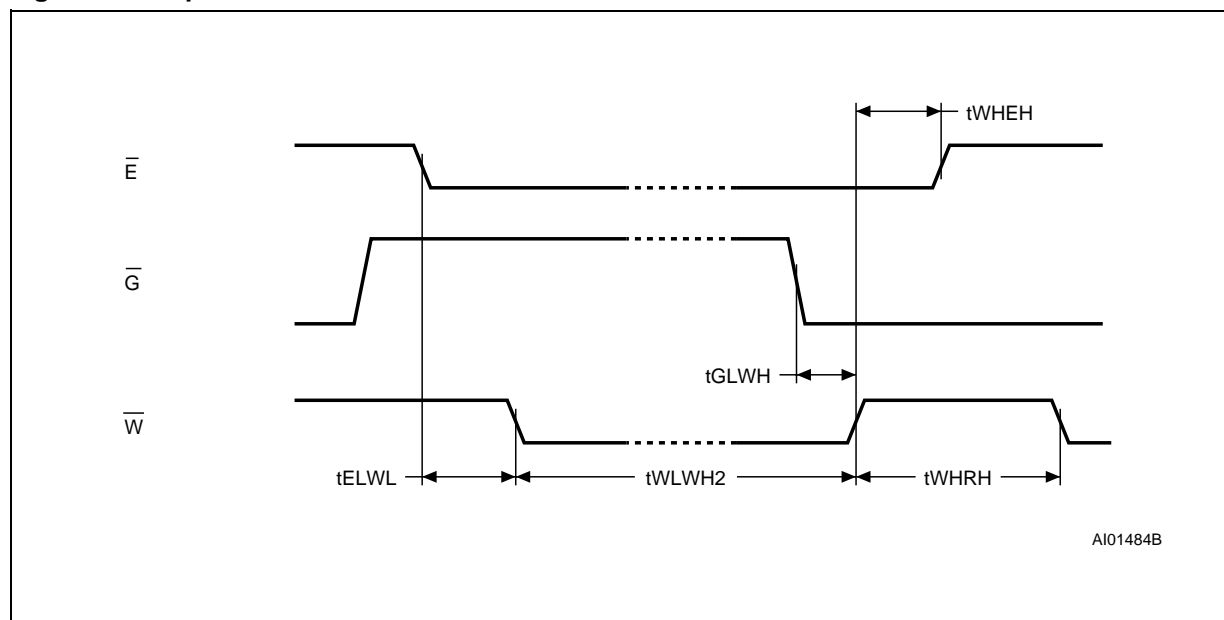
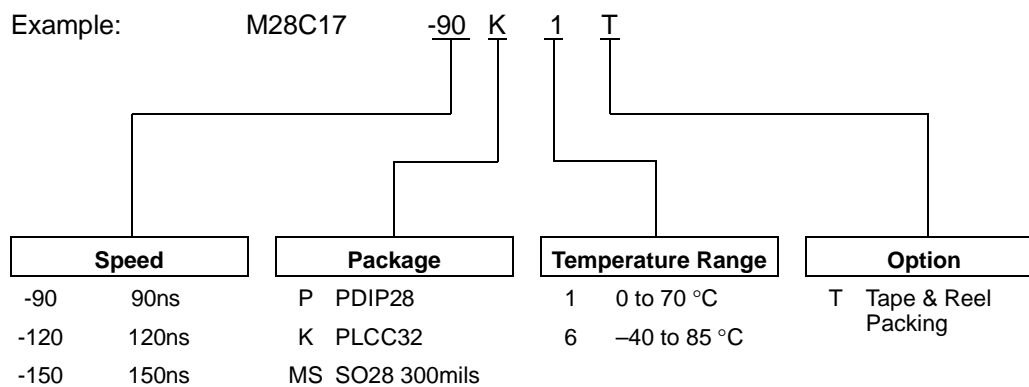

Table 10. Chip Erase AC Characteristics

(T_A = 0 to 70°C or -40 to 85°C; V_{CC} = 4.5V to 5.5V)

| Symbol | Parameter | Test Condition | Min | Max | Unit |
|-------------|--|------------------------------|-----|-----|---------|
| t_{ELWL} | Chip Enable Low to Write Enable Low | $\overline{G} = V_{CC} + 7V$ | 1 | | μs |
| t_{WHEH} | Write Enable High to Chip Enable High | $\overline{G} = V_{CC} + 7V$ | 0 | | ns |
| t_{WLWH2} | Write Enable Low to Write Enable High | $\overline{G} = V_{CC} + 7V$ | 10 | | ms |
| t_{GLWH} | Output Enable Low to Write Enable High | $\overline{G} = V_{CC} + 7V$ | 1 | | μs |
| t_{WHRH} | Write Enable High to Write Enable Low | $\overline{G} = V_{CC} + 7V$ | | 3 | ms |

ORDERING INFORMATION SCHEME



Devices are shipped from the factory with the memory content set at all "1's" (FFh).

For a list of available options (Package, etc...) or for further information on any aspect of this device, please contact the SGS-THOMSON Sales Office nearest to you.

PDIP28 - 28 pin Plastic DIP, 600 mils width

| Symb | mm | | | inches | | |
|----------|------|-------|-------|--------|-------|-------|
| | Typ | Min | Max | Typ | Min | Max |
| A | | 3.94 | 5.08 | | 0.155 | 0.200 |
| A1 | | 0.38 | 1.78 | | 0.015 | 0.070 |
| A2 | | 3.56 | 4.06 | | 0.140 | 0.160 |
| B | | 0.38 | 0.56 | | 0.015 | 0.021 |
| B1 | | 1.14 | 1.78 | | 0.045 | 0.070 |
| C | | 0.20 | 0.30 | | 0.008 | 0.012 |
| D | | 34.70 | 37.34 | | 1.366 | 1.470 |
| E | | 14.80 | 16.26 | | 0.583 | 0.640 |
| E1 | | 12.50 | 13.97 | | 0.492 | 0.550 |
| e1 | 2.54 | – | – | 0.100 | – | – |
| eA | | 15.20 | 17.78 | | 0.598 | 0.700 |
| L | | 3.05 | 3.82 | | 0.120 | 0.150 |
| S | | 1.02 | 2.29 | | 0.040 | 0.090 |
| α | | 0° | 15° | | 0° | 15° |
| N | | 28 | | | 28 | |

PDIP28

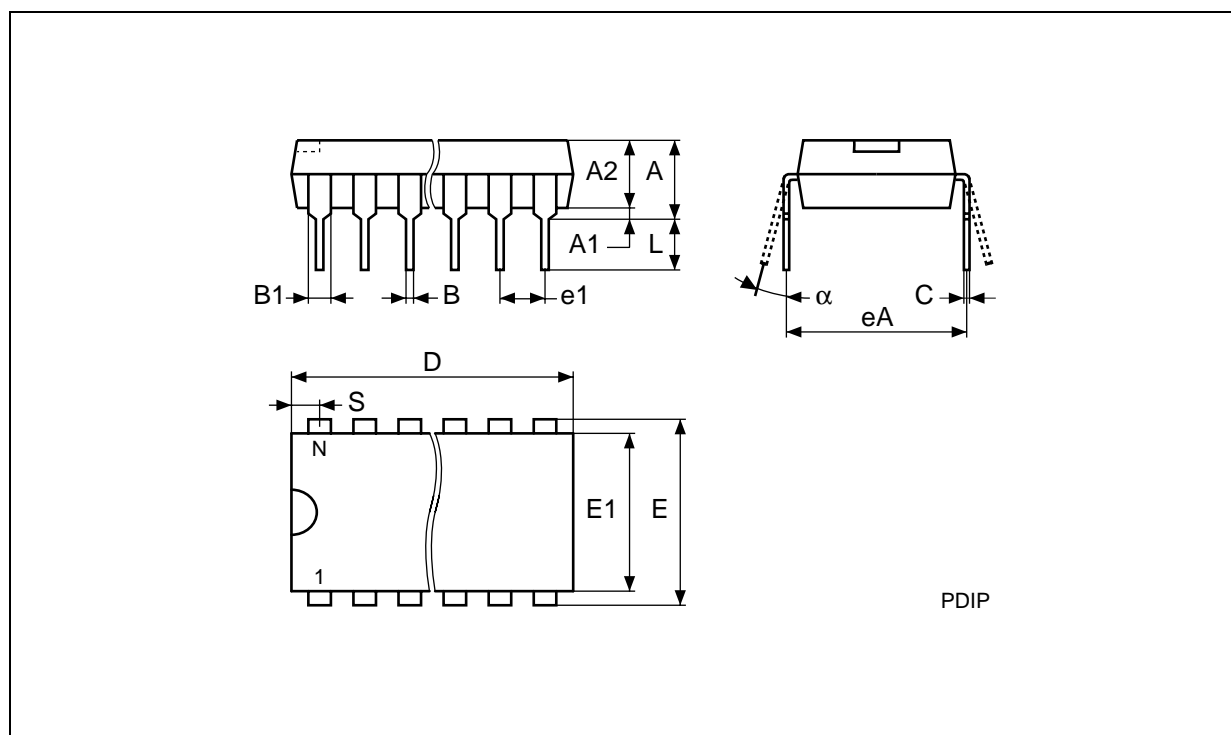

Drawing is not to scale.

PLCC32 - 32 lead Plastic Leaded Chip Carrier, rectangular

| Symb | mm | | | inches | | |
|------|------|-------|-------|--------|-------|-------|
| | Typ | Min | Max | Typ | Min | Max |
| A | | 2.54 | 3.56 | | 0.100 | 0.140 |
| A1 | | 1.52 | 2.41 | | 0.060 | 0.095 |
| B | | 0.33 | 0.53 | | 0.013 | 0.021 |
| B1 | | 0.66 | 0.81 | | 0.026 | 0.032 |
| D | | 12.32 | 12.57 | | 0.485 | 0.495 |
| D1 | | 11.35 | 11.56 | | 0.447 | 0.455 |
| D2 | | 9.91 | 10.92 | | 0.390 | 0.430 |
| E | | 14.86 | 15.11 | | 0.585 | 0.595 |
| E1 | | 13.89 | 14.10 | | 0.547 | 0.555 |
| E2 | | 12.45 | 13.46 | | 0.490 | 0.530 |
| e | 1.27 | – | – | 0.050 | – | – |
| j | 0.89 | – | – | 0.035 | – | – |
| N | | 32 | | | 32 | |
| Nd | | 7 | | | 7 | |
| Ne | | 9 | | | 9 | |
| CP | | | 0.10 | | | 0.004 |

PLCC32

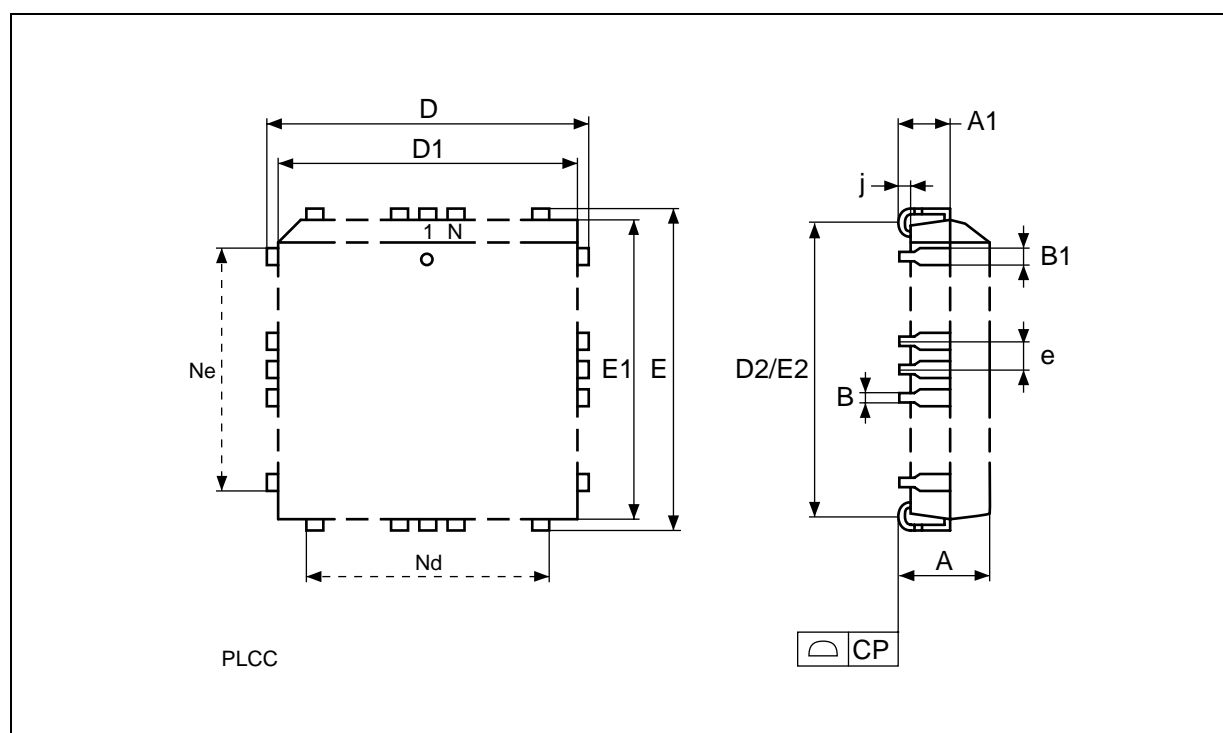

Drawing is not to scale.

SO28 - 28 lead Plastic Small Outline, 300 mils body width

| Symb | mm | | | inches | | |
|----------|------|-------|-------|--------|-------|-------|
| | Typ | Min | Max | Typ | Min | Max |
| A | | 2.46 | 2.64 | | 0.097 | 0.104 |
| A1 | | 0.13 | 0.29 | | 0.005 | 0.011 |
| A2 | | 2.29 | 2.39 | | 0.090 | 0.094 |
| B | | 0.35 | 0.48 | | 0.014 | 0.019 |
| C | | 0.23 | 0.32 | | 0.009 | 0.013 |
| D | | 17.81 | 18.06 | | 0.701 | 0.711 |
| E | | 7.42 | 7.59 | | 0.292 | 0.299 |
| e | 1.27 | - | - | 0.050 | - | - |
| H | | 10.16 | 10.41 | | 0.400 | 0.410 |
| L | | 0.61 | 1.02 | | 0.024 | 0.040 |
| α | | 0° | 8° | | 0° | 8° |
| N | 28 | | | 28 | | |
| CP | | | 0.10 | | | 0.004 |

SO28

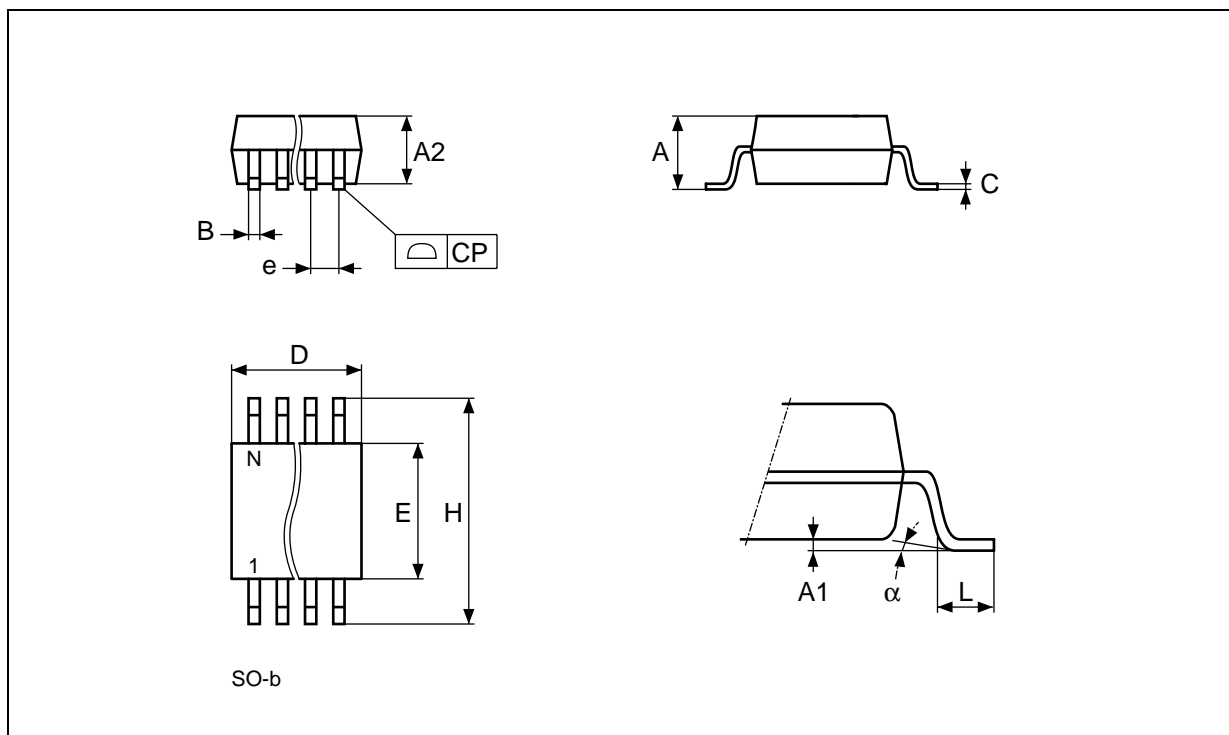

Drawing is not to scale.

Information furnished is believed to be accurate and reliable. However, SGS-THOMSON Microelectronics assumes no responsibility for the consequences of use of such information nor for any infringement of patents or other rights of third parties which may result from its use. No license is granted by implication or otherwise under any patent or patent rights of SGS-THOMSON Microelectronics. Specifications mentioned in this publication are subject to change without notice. This publication supersedes and replaces all information previously supplied. SGS-THOMSON Microelectronics products are not authorized for use as critical components in life support devices or systems without express written approval of SGS-THOMSON Microelectronics.

© 1997 SGS-THOMSON Microelectronics - All Rights Reserved

SGS-THOMSON Microelectronics GROUP OF COMPANIES
Australia - Brazil - Canada - China - France - Germany - Italy - Japan - Korea - Malaysia - Malta - Morocco - The Netherlands -
Singapore - Spain - Sweden - Switzerland - Taiwan - Thailand - United Kingdom - U.S.A.