

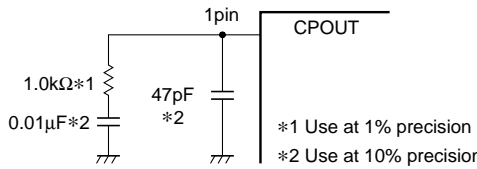

**PIN DESCRIPTION**

Pin Number	Symbol	Pin name	Input/Output	Function
1	CPOUT	Phase difference	Output	<p>Connect loop filter to this pin.</p>  <p>*1 Use at 1% precision *2 Use at 10% precision</p>
2	Vss2	Earthing pin	–	Connect to GND.
3	$\overline{AC}$	Auto-clear input	Input	When "L", this pin resets the internal IC circuit. Hysteresis input. Built-in pull-up resistor.
4	$\overline{CS}$	Chip select input	Input	This is the chip select input pin, and when serial data transmission is being carried out, it goes to "L". Hysteresis input. Built-in pull-up resistor.
5	SCK	Serial clock input	Input	When $\overline{CS}$ pin is "L", SIN serial data is taken in when SCK rises. Hysteresis input. Built-in pull-up resistor.
6	SIN	Serial data input	Input	This is the pin for serial input of data and addresses for the display control register and the display data memory. Hysteresis input. Built-in pull-up resistor.
7	TCK	External clock	Input	This is the pin for external clock input.
8	VDD1	Power pin	–	Please connect to +5V with the power pin.
9	P6	Port P6 output	Output	This is the output port. Port data is set by PTD6.
10	P7	Port P7 output	Output	This is the output port. Port data is set by PTD7.
11	Vss1	Earthing pin	–	Please connect to GND using circuit earthing pin.
12	P0/BLNK0	Port P0 output	Output	This pin can be toggled between port pin output and BLNK0 signal output.
13	P1/R	Port P1 output	Output	This pin can be toggled between port pin output and R signal output.
14	P2	Port P2 output	Output	This is the output port. Port data is set by PTD2.
15	P3/G	Port P3 output	Output	This pin can be toggled between port pin output and G signal output.
16	P4	Port P4 output	Output	This is the output port. Port data is set by PTD4.
17	P5/B	Port P5 output	Output	This pin can be toggled between port pin output and B signal output.
18	HOR	Horizontal synchronous signal input	Input	This pin inputs the horizontal synchronous signal. Hysteresis input.
19	VERT	Vertical synchronous signal input	Input	This pin inputs the vertical synchronous signal. Hysteresis input.
20	VDD2	Power pin	–	Please connect to +5V with the power pin.

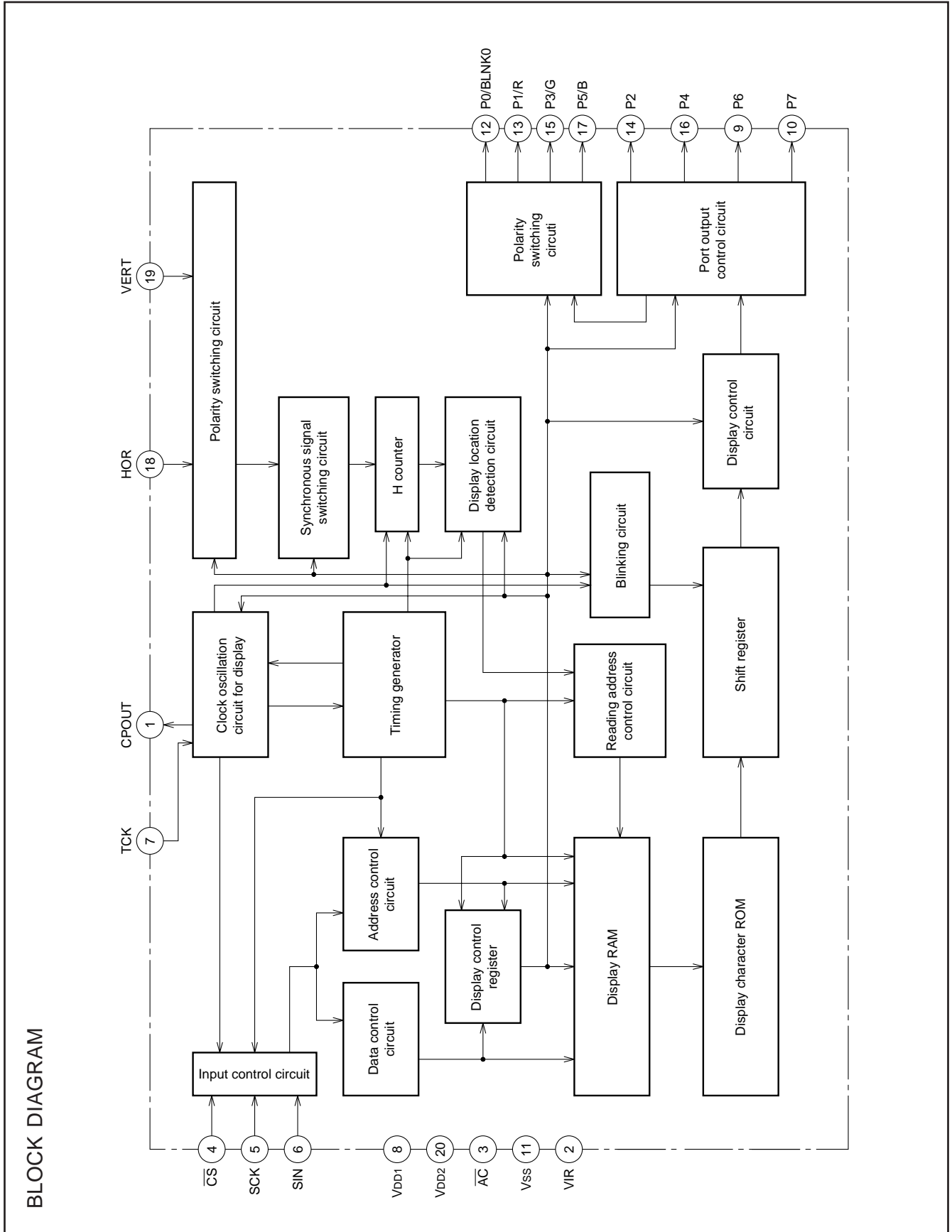

MITSUBISHI MICROCOMPUTERS  
M35046-XXXSP/FP

SCREEN CHARACTER and PATTERN DISPLAY CONTROLLERS

**MEMORY CONSTITUTION**

Address 000<sub>16</sub> to 11F<sub>16</sub> are assigned to the display RAM, address 120<sub>16</sub> to 128<sub>16</sub> are assigned to the display control registers. The internal circuit is reset and all display control registers (address 120<sub>16</sub> to 128<sub>16</sub>) are set to "0" when the AC pin level is "L". And then RAM is erased.

Memory constitution is shown in Figure 1.

**SCREEN CONSTITUTION**

The screen lines and rows are determined from each address of the display RAM. The screen constitution is shown in Figure 2.

	DAF	DAE	DAD	DAC	DAB	DAA	DA9	DA8	DA7	DA6	DA5	DA4	DA3	DA2	DA1	DA0
000 <sub>16</sub>	0	BB	BG	BR	BLINK	B	G	R	C7	C6	C5	C4	C3	C2	C1	C0
⋮	⋮	Background coloring			Blinking	Character color			Character code							
11F <sub>16</sub>	0	BB	BG	BR	BLINK	B	G	R	C7	C6	C5	C4	C3	C2	C1	C0
120 <sub>16</sub>	0	EXCK0	VJT	DIVS1	DIVS0	DIV10	DIV9	DIV8	DIV7	DIV6	DIV5	DIV4	DIV3	DIV2	DIV1	DIV0
121 <sub>16</sub>	0	RSEL0	PTD7	PTD6	PTD5	PTD4	PTD3	PTD2	PTD1	PTD0	PTC5	PTC4	PTC3	PTC2	PTC1	PTC0
122 <sub>16</sub>	0	RSEL1	SPACE2	SPACE1	SPACE0	TEST9	HP9	HP8	HP7	HP6	HP5	HP4	HP3	HP2	HP1	HP0
123 <sub>16</sub>	0	EXCK1	TEST3	TEST2	TEST1	TEST0	VP9	VP8	VP7	VP6	VP5	VP4	VP3	VP2	VP1	VP0
124 <sub>16</sub>	0	TEST14	TEST5	TEST4	DSP11	DSP10	DSP9	DSP8	DSP7	DSP6	DSP5	DSP4	DSP3	DSP2	DSP1	DSP0
125 <sub>16</sub>	0	TEST10	VSZ1H1	VSZ1H0	VSZ1L1	VSZ1L0	V1SZ1	V1SZ0	LIN9	LIN8	LIN7	LIN6	LIN5	LIN4	LIN3	LIN2
126 <sub>16</sub>	0	TEST11	VSZ2H1	VSZ2H0	VSZ2L1	VSZ2L0	V18SZ1	V18SZ0	LIN17	LIN16	LIN15	LIN14	LIN13	LIN12	LIN11	LIN10
127 <sub>16</sub>	0	TEST12	HSZ21	HSZ20	HSZ11	HSZ10	BETA14	TEST8	TEST7	TEST6	FB	FG	FR	RB	RG	RR
128 <sub>16</sub>	0	TEST13	BLINK2	BLINK1	BLINK0	DSPON	STOP	RAMERS	SYAD	BLK1	BLK0	POLH	POLV	VMASK	B/F	BCOL

Fig. 1 Memory constitution

Row Line	1	2	3	4	5	6	7	8	9	10	11	12	13	14	15	16	17	18	19	20	21	22	23	24
1	000 <sub>16</sub>	001 <sub>16</sub>	002 <sub>16</sub>	003 <sub>16</sub>	004 <sub>16</sub>	005 <sub>16</sub>	006 <sub>16</sub>	007 <sub>16</sub>	008 <sub>16</sub>	009 <sub>16</sub>	00A <sub>16</sub>	00B <sub>16</sub>	00C <sub>16</sub>	00D <sub>16</sub>	00E <sub>16</sub>	00F <sub>16</sub>	010 <sub>16</sub>	011 <sub>16</sub>	012 <sub>16</sub>	013 <sub>16</sub>	014 <sub>16</sub>	015 <sub>16</sub>	016 <sub>16</sub>	017 <sub>16</sub>
2	018 <sub>16</sub>	019 <sub>16</sub>	01A <sub>16</sub>	01B <sub>16</sub>	01C <sub>16</sub>	01D <sub>16</sub>	01E <sub>16</sub>	01F <sub>16</sub>	020 <sub>16</sub>	021 <sub>16</sub>	022 <sub>16</sub>	023 <sub>16</sub>	024 <sub>16</sub>	025 <sub>16</sub>	026 <sub>16</sub>	027 <sub>16</sub>	028 <sub>16</sub>	029 <sub>16</sub>	02A <sub>16</sub>	02B <sub>16</sub>	02C <sub>16</sub>	02D <sub>16</sub>	02E <sub>16</sub>	02F <sub>16</sub>
3	030 <sub>16</sub>	031 <sub>16</sub>	032 <sub>16</sub>	033 <sub>16</sub>	034 <sub>16</sub>	035 <sub>16</sub>	036 <sub>16</sub>	037 <sub>16</sub>	038 <sub>16</sub>	039 <sub>16</sub>	03A <sub>16</sub>	03B <sub>16</sub>	03C <sub>16</sub>	03D <sub>16</sub>	03E <sub>16</sub>	03F <sub>16</sub>	040 <sub>16</sub>	041 <sub>16</sub>	042 <sub>16</sub>	043 <sub>16</sub>	044 <sub>16</sub>	045 <sub>16</sub>	046 <sub>16</sub>	047 <sub>16</sub>
4	048 <sub>16</sub>	049 <sub>16</sub>	04A <sub>16</sub>	04B <sub>16</sub>	04C <sub>16</sub>	04D <sub>16</sub>	04E <sub>16</sub>	04F <sub>16</sub>	050 <sub>16</sub>	051 <sub>16</sub>	052 <sub>16</sub>	053 <sub>16</sub>	054 <sub>16</sub>	055 <sub>16</sub>	056 <sub>16</sub>	057 <sub>16</sub>	058 <sub>16</sub>	059 <sub>16</sub>	05A <sub>16</sub>	05B <sub>16</sub>	05C <sub>16</sub>	05D <sub>16</sub>	05E <sub>16</sub>	05F <sub>16</sub>
5	060 <sub>16</sub>	061 <sub>16</sub>	062 <sub>16</sub>	063 <sub>16</sub>	064 <sub>16</sub>	065 <sub>16</sub>	066 <sub>16</sub>	067 <sub>16</sub>	068 <sub>16</sub>	069 <sub>16</sub>	06A <sub>16</sub>	06B <sub>16</sub>	06C <sub>16</sub>	06D <sub>16</sub>	06E <sub>16</sub>	06F <sub>16</sub>	070 <sub>16</sub>	071 <sub>16</sub>	072 <sub>16</sub>	073 <sub>16</sub>	074 <sub>16</sub>	075 <sub>16</sub>	076 <sub>16</sub>	077 <sub>16</sub>
6	078 <sub>16</sub>	079 <sub>16</sub>	07A <sub>16</sub>	07B <sub>16</sub>	07C <sub>16</sub>	07D <sub>16</sub>	07E <sub>16</sub>	07F <sub>16</sub>	080 <sub>16</sub>	081 <sub>16</sub>	082 <sub>16</sub>	083 <sub>16</sub>	084 <sub>16</sub>	085 <sub>16</sub>	086 <sub>16</sub>	087 <sub>16</sub>	088 <sub>16</sub>	089 <sub>16</sub>	08A <sub>16</sub>	08B <sub>16</sub>	08C <sub>16</sub>	08D <sub>16</sub>	08E <sub>16</sub>	08F <sub>16</sub>
7	090 <sub>16</sub>	091 <sub>16</sub>	092 <sub>16</sub>	093 <sub>16</sub>	094 <sub>16</sub>	095 <sub>16</sub>	096 <sub>16</sub>	097 <sub>16</sub>	098 <sub>16</sub>	099 <sub>16</sub>	09A <sub>16</sub>	09B <sub>16</sub>	09C <sub>16</sub>	09D <sub>16</sub>	09E <sub>16</sub>	09F <sub>16</sub>	0A0 <sub>16</sub>	0A1 <sub>16</sub>	0A2 <sub>16</sub>	0A3 <sub>16</sub>	0A4 <sub>16</sub>	0A5 <sub>16</sub>	0A6 <sub>16</sub>	0A7 <sub>16</sub>
8	0A8 <sub>16</sub>	0A9 <sub>16</sub>	0AA <sub>16</sub>	0AB <sub>16</sub>	0AC <sub>16</sub>	0AD <sub>16</sub>	0AE <sub>16</sub>	0AF <sub>16</sub>	0B0 <sub>16</sub>	0B1 <sub>16</sub>	0B2 <sub>16</sub>	0B3 <sub>16</sub>	0B4 <sub>16</sub>	0B5 <sub>16</sub>	0B6 <sub>16</sub>	0B7 <sub>16</sub>	0B8 <sub>16</sub>	0B9 <sub>16</sub>	0BA <sub>16</sub>	0BB <sub>16</sub>	0BC <sub>16</sub>	0BD <sub>16</sub>	0BE <sub>16</sub>	0BF <sub>16</sub>
9	0C0 <sub>16</sub>	0C1 <sub>16</sub>	0C2 <sub>16</sub>	0C3 <sub>16</sub>	0C4 <sub>16</sub>	0C5 <sub>16</sub>	0C6 <sub>16</sub>	0C7 <sub>16</sub>	0C8 <sub>16</sub>	0C9 <sub>16</sub>	0CA <sub>16</sub>	0CB <sub>16</sub>	0CC <sub>16</sub>	0CD <sub>16</sub>	0CE <sub>16</sub>	0CF <sub>16</sub>	0D0 <sub>16</sub>	0D1 <sub>16</sub>	0D2 <sub>16</sub>	0D3 <sub>16</sub>	0D4 <sub>16</sub>	0D5 <sub>16</sub>	0D6 <sub>16</sub>	0D7 <sub>16</sub>
10	0D8 <sub>16</sub>	0D9 <sub>16</sub>	0DA <sub>16</sub>	0DB <sub>16</sub>	0DC <sub>16</sub>	0DD <sub>16</sub>	0DE <sub>16</sub>	0DF <sub>16</sub>	0E0 <sub>16</sub>	0E1 <sub>16</sub>	0E2 <sub>16</sub>	0E3 <sub>16</sub>	0E4 <sub>16</sub>	0E5 <sub>16</sub>	0E6 <sub>16</sub>	0E7 <sub>16</sub>	0E8 <sub>16</sub>	0E9 <sub>16</sub>	0EA <sub>16</sub>	0EB <sub>16</sub>	0EC <sub>16</sub>	0ED <sub>16</sub>	0EE <sub>16</sub>	0EF <sub>16</sub>
11	0F0 <sub>16</sub>	0F1 <sub>16</sub>	0F2 <sub>16</sub>	0F3 <sub>16</sub>	0F4 <sub>16</sub>	0F5 <sub>16</sub>	0F6 <sub>16</sub>	0F7 <sub>16</sub>	0F8 <sub>16</sub>	0F9 <sub>16</sub>	0FA <sub>16</sub>	0FB <sub>16</sub>	0FC <sub>16</sub>	0FD <sub>16</sub>	0FE <sub>16</sub>	0FF <sub>16</sub>	100 <sub>16</sub>	101 <sub>16</sub>	102 <sub>16</sub>	103 <sub>16</sub>	104 <sub>16</sub>	105 <sub>16</sub>	106 <sub>16</sub>	107 <sub>16</sub>
12	108 <sub>16</sub>	109 <sub>16</sub>	10A <sub>16</sub>	10B <sub>16</sub>	10C <sub>16</sub>	10D <sub>16</sub>	10E <sub>16</sub>	10F <sub>16</sub>	110 <sub>16</sub>	111 <sub>16</sub>	112 <sub>16</sub>	113 <sub>16</sub>	114 <sub>16</sub>	115 <sub>16</sub>	116 <sub>16</sub>	117 <sub>16</sub>	118 <sub>16</sub>	119 <sub>16</sub>	11A <sub>16</sub>	11B <sub>16</sub>	11C <sub>16</sub>	11D <sub>16</sub>	11E <sub>16</sub>	11F <sub>16</sub>

f The hexadecimal numbers in the boxes show the display RAM address.

Fig. 2 Screen constitution

**REGISTERS DESCRIPTION**

(1) Address 120<sub>16</sub>

DA	Register	Contents		Remarks																			
		Status	Function																				
0	DIV0	0	Set external clock frequency value of horizontal oscillation frequency.	Set display frequency by frequency value setting. Set N1 to be "N1=fosc/fH". fosc(MHz) : External clock frequency for TCK pin (=display frequency) fH(kHz) : Horizontal synchronous signal frequency for HOR pin Set registers DIVS0, DIVS1 (address 120 <sub>16</sub> ), RSEL0 (address 121 <sub>16</sub> ) and RSEL1 (address 122 <sub>16</sub> ) according to external clock frequency. For details, see (2) Setting display frequencies under Register Supplementary Description.  Any of this settings above is required only when EXCK1=1, EXCK0=1.																			
		1																					
1	DIV1	0	$N1 = \sum_{n=0}^{10} (DIVn \times 2^n)$ N1: frequency value																				
		1																					
2	DIV2	0																					
		1																					
3	DIV3	0				Horizontal synchronized signal																	
		1																					
4	DIV4	0					External clock																
		1																					
5	DIV5	0						Clock number (N1)															
		1																					
6	DIV6	0																					
		1																					
7	DIV7	0																					
		1																					
8	DIV8	0																					
		1																					
9	DIV9	0																					
		1																					
A	DIV10	0																					
		1																					
B	DIVS0	0				For details, see (2) Setting display frequencies under Register Supplementary Description.					Set display frequency area.												
		1																					
C	DIVS1	0																					
		1																					
D	VJT	0				It should be fixed to "0".																	
		1				Alleviates continuous vertical jitters.																	
E	EXCK0	0				<table border="1"> <thead> <tr> <th>EXCK1</th> <th>EXCK0</th> <th>Display clock input</th> </tr> </thead> <tbody> <tr> <td>0</td> <td>0</td> <td>20 to 30MHz</td> </tr> <tr> <td>0</td> <td>1</td> <td>Do not set</td> </tr> <tr> <td>1</td> <td>0</td> <td>Do not set</td> </tr> <tr> <td>1</td> <td>1</td> <td>20 to 80MHz</td> </tr> </tbody> </table>	EXCK1	EXCK0	Display clock input		0	0	20 to 30MHz	0	1	Do not set	1	0	Do not set	1	1	20 to 80MHz	See setting External Clock Input Mode (to be input from the TCK terminal). EXCK1 : address 123 <sub>16</sub>
		EXCK1				EXCK0	Display clock input																
0	0	20 to 30MHz																					
0	1	Do not set																					
1	0	Do not set																					
1	1	20 to 80MHz																					
1																							

## SCREEN CHARACTER and PATTERN DISPLAY CONTROLLERS

(2) Address 121<sub>16</sub>

DA	Register	Contents		Remarks
		Status	Function	
0	PTC0	0	P0 output (port P0). Port data is set by PTD0.	BLNK0 outputs blanking signal. Blanking status is determined by BLK0, BLK1, and DSP0 to DSP11 settings.
		1	BLNK0 output. Polarity is set by PTD0.	
1	PTC1	0	P1 output (port P1). Port data is set by PTD1.	
		1	R signal output. Polarity is set by PTD1.	
2	PTC2	0	P2 output (port P2). Port data is set by PTD2.	
		1	Can not be used.	
3	PTC3	0	P3 output (port P3). Port data is set by PTD3.	
		1	G signal output. Polarity is set by PTD3.	
4	PTC4	0	P4 output (port P4). Port data is set by PTD4.	
		1	Can not be used.	
5	PTC5	0	P5 output (port P5). Port data is set by PTD5.	
		1	B signal output. Polarity is set by PTD5.	
6	PTD0 (Note)	0	"L" output (P0 output) or negative polarity output (BLNK0 output).	P0 pin data control.
		1	"H" output (P0 output) or positive polarity output (BLNK0 output).	
7	PTD1 (Note)	0	"L" output (P1 output) or negative polarity output (R signal output).	P1 pin data control.
		1	"H" output (P1 output) or positive polarity output (R signal output).	
8	PTD2 (Note)	0	"L" output (P2 output).	P2 pin exclusive port output state control.
		1	"H" output (P2 output).	
9	PTD3 (Note)	0	"L" output (P3 output) or negative polarity output (G signal output).	P3 pin data control.
		1	"H" output (P3 output) or positive polarity output (G signal output).	
A	PTD4 (Note)	0	"L" output (P2 output).	P4 pin exclusive port output state control.
		1	"H" output (P2 output).	
B	PTD5 (Note)	0	"L" output (P5 output) or negative polarity output (B signal output).	P5 pin data control.
		1	"H" output (P5 output) or positive polarity output (B signal output).	
C	PTD6 (Note)	0	"L" output (P6 output).	P6 pin exclusive port output state control.
		1	"H" output (P6 output).	
D	PTD7 (Note)	0	"L" output (P7 output).	P7 pin exclusive port output state control.
		1	"H" output (P7 output).	
E	RSEL0	0	For details, see (2) Setting display frequencies under Register Supplementary Description.	Set display frequency area.
		1	To be used when EXCK0=1 and EXCK1=1.	

**Note.** To determined this register, input clock (at least one clock) to the external clock pin (TCK).

MITSUBISHI MICROCOMPUTERS  
M35046-XXXSP/FP

SCREEN CHARACTER and PATTERN DISPLAY CONTROLLERS

(3) Address 12216

DA	Register	Contents		Remarks																																											
		Status	Function																																												
0	HP0 (LSB)	0	If HS is the horizontal display start location, $HS = T \times \sum_{n=0}^9 2^n HP_n + 6$ T: The cycle of display frequency 1000 settings are possible.	Horizontal display start location is specified using the 10 bits from HP9 to HP0. HP9 to HP0 = (0000000002) and (00000101112) setting is forbidden. Note : In case of B/F register is "0".																																											
		1																																													
1	HP1	0																																													
		1																																													
2	HP2	0																																													
		1																																													
3	HP3	0																																													
		1																																													
4	HP4	0																																													
		1																																													
5	HP5	0																																													
		1																																													
6	HP6	0																																													
		1																																													
7	HP7	0																																													
		1																																													
8	HP8	0																																													
		1																																													
9	HP9 (MSB)	0																																													
		1																																													
A	TEST9	0		It should be fixed to "0".																																											
		1		Can not be used.																																											
B	SPACE0	0	<table border="1"> <thead> <tr> <th colspan="3">SPACE</th> <th rowspan="2">Number of Lines and Space (⊕ represents space)</th> </tr> <tr> <th>2</th> <th>1</th> <th>0</th> </tr> </thead> <tbody> <tr> <td>0</td> <td>0</td> <td>0</td> <td>12</td> </tr> <tr> <td>0</td> <td>0</td> <td>1</td> <td>1 ⊕ 10   1</td> </tr> <tr> <td>0</td> <td>1</td> <td>0</td> <td>2 ⊕ 8   2</td> </tr> <tr> <td>0</td> <td>1</td> <td>1</td> <td>3 ⊕ 6   3</td> </tr> <tr> <td>1</td> <td>0</td> <td>0</td> <td>4 ⊕ 4   4</td> </tr> <tr> <td>1</td> <td>0</td> <td>1</td> <td>5 ⊕ 2   5</td> </tr> <tr> <td>1</td> <td>1</td> <td>0</td> <td>6 ⊕ 6</td> </tr> <tr> <td>1</td> <td>1</td> <td>1</td> <td>6 ⊕   6</td> </tr> </tbody> </table>	SPACE					Number of Lines and Space (⊕ represents space)	2	1	0	0	0	0	12	0	0	1	1 ⊕ 10   1	0	1	0	2 ⊕ 8   2	0	1	1	3 ⊕ 6   3	1	0	0	4 ⊕ 4   4	1	0	1	5 ⊕ 2   5	1	1	0	6 ⊕ 6	1	1	1	6 ⊕   6	Leave one line worth of space in the vertical direction. For example, 6 ⊕ 6 indicates two sets of 6 lines with a line of spaces between lines 6 and 7. A line is 18 × N horizontal scan lines. N is determined by the character size in the vertical direction as follows: ×1 ... N = 1    ×2 ... N = 2 ×3 ... N = 3    ×4 ... N = 4		
		SPACE								Number of Lines and Space (⊕ represents space)																																					
2	1	0																																													
0	0	0		12																																											
0	0	1		1 ⊕ 10   1																																											
0	1	0		2 ⊕ 8   2																																											
0	1	1		3 ⊕ 6   3																																											
1	0	0		4 ⊕ 4   4																																											
1	0	1		5 ⊕ 2   5																																											
1	1	0		6 ⊕ 6																																											
1	1	1	6 ⊕   6																																												
1	⊕ represents one line worth of spaces.																																														
C	SPACE1	0	<table border="1"> <thead> <tr> <th colspan="3">SPACE</th> <th rowspan="2">Number of Lines and Space (⊕ represents space)</th> </tr> <tr> <th>2</th> <th>1</th> <th>0</th> </tr> </thead> <tbody> <tr> <td>0</td> <td>0</td> <td>0</td> <td>12</td> </tr> <tr> <td>0</td> <td>0</td> <td>1</td> <td>1 ⊕ 10   1</td> </tr> <tr> <td>0</td> <td>1</td> <td>0</td> <td>2 ⊕ 8   2</td> </tr> <tr> <td>0</td> <td>1</td> <td>1</td> <td>3 ⊕ 6   3</td> </tr> <tr> <td>1</td> <td>0</td> <td>0</td> <td>4 ⊕ 4   4</td> </tr> <tr> <td>1</td> <td>0</td> <td>1</td> <td>5 ⊕ 2   5</td> </tr> <tr> <td>1</td> <td>1</td> <td>0</td> <td>6 ⊕ 6</td> </tr> <tr> <td>1</td> <td>1</td> <td>1</td> <td>6 ⊕   6</td> </tr> </tbody> </table>	SPACE			Number of Lines and Space (⊕ represents space)	2	1	0	0	0	0	12	0	0	1	1 ⊕ 10   1	0	1	0	2 ⊕ 8   2	0	1	1	3 ⊕ 6   3	1	0	0	4 ⊕ 4   4	1	0	1	5 ⊕ 2   5	1	1	0	6 ⊕ 6	1	1	1	6 ⊕   6	Leave one line worth of space in the vertical direction. For example, 6 ⊕ 6 indicates two sets of 6 lines with a line of spaces between lines 6 and 7. A line is 18 × N horizontal scan lines. N is determined by the character size in the vertical direction as follows: ×1 ... N = 1    ×2 ... N = 2 ×3 ... N = 3    ×4 ... N = 4				
		SPACE			Number of Lines and Space (⊕ represents space)																																										
2	1	0																																													
0	0	0		12																																											
0	0	1		1 ⊕ 10   1																																											
0	1	0		2 ⊕ 8   2																																											
0	1	1		3 ⊕ 6   3																																											
1	0	0		4 ⊕ 4   4																																											
1	0	1		5 ⊕ 2   5																																											
1	1	0		6 ⊕ 6																																											
1	1	1	6 ⊕   6																																												
1	⊕ represents one line worth of spaces.																																														
D	SPACE2	0	<table border="1"> <thead> <tr> <th colspan="3">SPACE</th> <th rowspan="2">Number of Lines and Space (⊕ represents space)</th> </tr> <tr> <th>2</th> <th>1</th> <th>0</th> </tr> </thead> <tbody> <tr> <td>0</td> <td>0</td> <td>0</td> <td>12</td> </tr> <tr> <td>0</td> <td>0</td> <td>1</td> <td>1 ⊕ 10   1</td> </tr> <tr> <td>0</td> <td>1</td> <td>0</td> <td>2 ⊕ 8   2</td> </tr> <tr> <td>0</td> <td>1</td> <td>1</td> <td>3 ⊕ 6   3</td> </tr> <tr> <td>1</td> <td>0</td> <td>0</td> <td>4 ⊕ 4   4</td> </tr> <tr> <td>1</td> <td>0</td> <td>1</td> <td>5 ⊕ 2   5</td> </tr> <tr> <td>1</td> <td>1</td> <td>0</td> <td>6 ⊕ 6</td> </tr> <tr> <td>1</td> <td>1</td> <td>1</td> <td>6 ⊕   6</td> </tr> </tbody> </table>	SPACE			Number of Lines and Space (⊕ represents space)	2	1	0	0	0	0	12	0	0	1	1 ⊕ 10   1	0	1	0	2 ⊕ 8   2	0	1	1	3 ⊕ 6   3	1	0	0	4 ⊕ 4   4	1	0	1	5 ⊕ 2   5	1	1	0	6 ⊕ 6	1	1	1	6 ⊕   6	Leave one line worth of space in the vertical direction. For example, 6 ⊕ 6 indicates two sets of 6 lines with a line of spaces between lines 6 and 7. A line is 18 × N horizontal scan lines. N is determined by the character size in the vertical direction as follows: ×1 ... N = 1    ×2 ... N = 2 ×3 ... N = 3    ×4 ... N = 4				
		SPACE			Number of Lines and Space (⊕ represents space)																																										
2	1	0																																													
0	0	0		12																																											
0	0	1		1 ⊕ 10   1																																											
0	1	0		2 ⊕ 8   2																																											
0	1	1		3 ⊕ 6   3																																											
1	0	0		4 ⊕ 4   4																																											
1	0	1		5 ⊕ 2   5																																											
1	1	0		6 ⊕ 6																																											
1	1	1	6 ⊕   6																																												
1	⊕ represents one line worth of spaces.																																														
E	RSEL1	0	For details, see (2) Setting display frequencies under Register Supplementary Description. To be used when EXCK0=1 and EXCK1=1.	Set display frequency area.																																											
		1																																													

MITSUBISHI MICROCOMPUTERS  
M35046-XXXSP/FP

SCREEN CHARACTER and PATTERN DISPLAY CONTROLLERS

(4) Address 123<sub>16</sub>

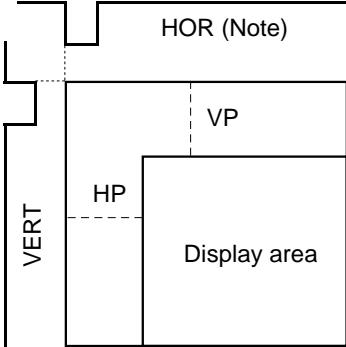
DA	Register	Contents		Remarks	
		Status	Function		
0	VP0 (LSB)	0	If VS is the vertical display start location,	The vertical start location is specified using the 10 bits from VP9 to VP0. VP9 to VP0 = (0000000002) setting is forbidden. Note : In case of B/F register is "0".	
		1	$VS = H \times \sum_{n=0}^9 2^n VP_n$		
1	VP1	0	H: Cycle with the horizontal synchronizing pulse 1023 settings are possible.		
		1			
2	VP2	0	 <p>The diagram shows a vertical sync pulse (VERT) and a horizontal sync pulse (HOR). The vertical sync pulse is followed by a vertical sync period (VP) and a horizontal sync period (HP). The display area is shown as a rectangle within the VP and HP periods.</p>		
		1			
3	VP3	0			
		1			
4	VP4	0			
		1			
5	VP5	0			
		1			
6	VP6	0			
		1			
7	VP7	0			
		1			
8	VP8	0			
		1			
9	VP9 (MSB)	0			
		1			
A	TEST0	0	It should be fixed to "0".		
		1	Can not be used.		
B	TEST1	0	It should be fixed to "0".		
		1	Can not be used.		
C	TEST2	0	It should be fixed to "0".		
		1	Can not be used.		
D	TEST3	0	It should be fixed to "0".		
		1	Can not be used.		
E	EXCK1	0	For setting. See Register EXCK0 (address 120 <sub>16</sub> ).	Sets input mode of external clock (input from TCK pin).	
		1			



SCREEN CHARACTER and PATTERN DISPLAY CONTROLLERS

(5) Address 124<sub>16</sub>

DA	Register	Contents		Remarks
		Status	Function	
0	DSP0	0	Blanking is in the display mode specified by BLK0 and BLK1. (Note)	Sets the display mode of line 1.
		1	Blanking is in the display mode specified by except BLK0 and BLK1. (Note)	
1	DSP1	0	Blanking is in the display mode specified by BLK0 and BLK1. (Note)	Sets the display mode of line 2.
		1	Blanking is in the display mode specified by except BLK0 and BLK1. (Note)	
2	DSP2	0	Blanking is in the display mode specified by BLK0 and BLK1. (Note)	Sets the display mode of line 3.
		1	Blanking is in the display mode specified by except BLK0 and BLK1. (Note)	
3	DSP3	0	Blanking is in the display mode specified by BLK0 and BLK1. (Note)	Sets the display mode of line 4.
		1	Blanking is in the display mode specified by except BLK0 and BLK1. (Note)	
4	DSP4	0	Blanking is in the display mode specified by BLK0 and BLK1. (Note)	Sets the display mode of line 5.
		1	Blanking is in the display mode specified by except BLK0 and BLK1. (Note)	
5	DSP5	0	Blanking is in the display mode specified by BLK0 and BLK1. (Note)	Sets the display mode of line 6.
		1	Blanking is in the display mode specified by except BLK0 and BLK1. (Note)	
6	DSP6	0	Blanking is in the display mode specified by BLK0 and BLK1. (Note)	Sets the display mode of line 7.
		1	Blanking is in the display mode specified by except BLK0 and BLK1. (Note)	
7	DSP7	0	Blanking is in the display mode specified by BLK0 and BLK1. (Note)	Sets the display mode of line 8.
		1	Blanking is in the display mode specified by except BLK0 and BLK1. (Note)	
8	DSP8	0	Blanking is in the display mode specified by BLK0 and BLK1. (Note)	Sets the display mode of line 9.
		1	Blanking is in the display mode specified by except BLK0 and BLK1. (Note)	
9	DSP9	0	Blanking is in the display mode specified by BLK0 and BLK1. (Note)	Sets the display mode of line 10.
		1	Blanking is in the display mode specified by except BLK0 and BLK1. (Note)	
A	DSP10	0	Blanking is in the display mode specified by BLK0 and BLK1. (Note)	Sets the display mode of line 11.
		1	Blanking is in the display mode specified by except BLK0 and BLK1. (Note)	
B	DSP11	0	Blanking is in the display mode specified by BLK0 and BLK1. (Note)	Sets the display mode of line 12.
		1	Blanking is in the display mode specified by except BLK0 and BLK1. (Note)	
C	TEST4	0	It should be fixed to "0".	
		1	Can not be used.	
D	TEST5	0	It should be fixed to "0".	
		1	Can not be used.	
E	TEST14	0	Can not be used.	
		1	It should be fixed to "1".	

Note: Refer to DISPLAY FORM1.

MITSUBISHI MICROCOMPUTERS  
M35046-XXXSP/FP

SCREEN CHARACTER and PATTERN DISPLAY CONTROLLERS

(6) Address 125<sub>16</sub>

DA	Register	Contents		Remarks												
		Status	Function													
0	LIN2	0	The first line is set by VSZ1L0 and VSZ1L1. The second to 12th lines are set by VSZ2L0 and VSZ2L1.	Character size setting in the vertical direction for the 2nd line.												
		1	The first line is set by VSZ1H0 and VSZ1H1. The second to 12th lines are set by VSZ2H0 and VSZ2H1.													
1	LIN3	0	The first line is set by VSZ1L0 and VSZ1L1. The second to 12th lines are set by VSZ2L0 and VSZ2L1.	Character size setting in the vertical direction for the 3rd line.												
		1	The first line is set by VSZ1H0 and VSZ1H1. The second to 12th lines are set by VSZ2H0 and VSZ2H1.													
2	LIN4	0	The first line is set by VSZ1L0 and VSZ1L1. The second to 12th lines are set by VSZ2L0 and VSZ2L1.	Character size setting in the vertical direction for the 4th line.												
		1	The first line is set by VSZ1H0 and VSZ1H1. The second to 12th lines are set by VSZ2H0 and VSZ2H1.													
3	LIN5	0	The first line is set by VSZ1L0 and VSZ1L1. The second to 12th lines are set by VSZ2L0 and VSZ2L1.	Character size setting in the vertical direction for the 5th line.												
		1	The first line is set by VSZ1H0 and VSZ1H1. The second to 12th lines are set by VSZ2H0 and VSZ2H1.													
4	LIN6	0	The first line is set by VSZ1L0 and VSZ1L1. The second to 12th lines are set by VSZ2L0 and VSZ2L1.	Character size setting in the vertical direction for the 6th line.												
		1	The first line is set by VSZ1H0 and VSZ1H1. The second to 12th lines are set by VSZ2H0 and VSZ2H1.													
5	LIN7	0	The first line is set by VSZ1L0 and VSZ1L1. The second to 12th lines are set by VSZ2L0 and VSZ2L1.	Character size setting in the vertical direction for the 7th line.												
		1	The first line is set by VSZ1H0 and VSZ1H1. The second to 12th lines are set by VSZ2H0 and VSZ2H1.													
6	LIN8	0	The first line is set by VSZ1L0 and VSZ1L1. The second to 12th lines are set by VSZ2L0 and VSZ2L1.	Character size setting in the vertical direction for the 8th line.												
		1	The first line is set by VSZ1H0 and VSZ1H1. The second to 12th lines are set by VSZ2H0 and VSZ2H1.													
7	LIN9	0	The first line is set by VSZ1L0 and VSZ1L1. The second to 12th lines are set by VSZ2L0 and VSZ2L1.	Character size setting in the vertical direction for the 9th line.												
		1	The first line is set by VSZ1H0 and VSZ1H1. The second to 12th lines are set by VSZ2H0 and VSZ2H1.													
8	V1SZ0	0	H: Cycle with the horizontal synchronizing pulse	Character size setting in the vertical direction for the 1st line. (display monitor 1 to 12 line)												
		1	<table border="1"> <thead> <tr> <th>V1SZ1</th> <th>V1SZ0</th> <th>Vertical direction size</th> </tr> </thead> <tbody> <tr> <td>0</td> <td>0</td> <td>1H/dot</td> </tr> <tr> <td>0</td> <td>1</td> <td>2H/dot</td> </tr> <tr> <td>1</td> <td>0</td> <td>3H/dot</td> </tr> <tr> <td>1</td> <td>1</td> <td>4H/dot</td> </tr> </tbody> </table>		V1SZ1	V1SZ0	Vertical direction size	0	0	1H/dot	0	1	2H/dot	1	0	3H/dot
V1SZ1	V1SZ0	Vertical direction size														
0	0	1H/dot														
0	1	2H/dot														
1	0	3H/dot														
1	1	4H/dot														
9	V1SZ1	0														
		1														
A	VSZ1L0	0	H: Cycle with the horizontal synchronizing pulse	Character size setting in the vertical direction (display monitor 1 line) at "0" state in register LIN2 to LIN17.												
		1	<table border="1"> <thead> <tr> <th>VSZ1L1</th> <th>VSZ1L0</th> <th>Vertical direction size</th> </tr> </thead> <tbody> <tr> <td>0</td> <td>0</td> <td>1H/dot</td> </tr> <tr> <td>0</td> <td>1</td> <td>2H/dot</td> </tr> <tr> <td>1</td> <td>0</td> <td>3H/dot</td> </tr> <tr> <td>1</td> <td>1</td> <td>4H/dot</td> </tr> </tbody> </table>		VSZ1L1	VSZ1L0	Vertical direction size	0	0	1H/dot	0	1	2H/dot	1	0	3H/dot
VSZ1L1	VSZ1L0	Vertical direction size														
0	0	1H/dot														
0	1	2H/dot														
1	0	3H/dot														
1	1	4H/dot														
B	VSZ1L1	0														
		1														
C	VSZ1H0	0	H: Cycle with the horizontal synchronizing pulse	Character size setting in the vertical direction (display monitor 1 line) at "1" state in register LIN2 to LIN17.												
		1	<table border="1"> <thead> <tr> <th>VSZ1H1</th> <th>VSZ1H0</th> <th>Vertical direction size</th> </tr> </thead> <tbody> <tr> <td>0</td> <td>0</td> <td>1H/dot</td> </tr> <tr> <td>0</td> <td>1</td> <td>2H/dot</td> </tr> <tr> <td>1</td> <td>0</td> <td>3H/dot</td> </tr> <tr> <td>1</td> <td>1</td> <td>4H/dot</td> </tr> </tbody> </table>		VSZ1H1	VSZ1H0	Vertical direction size	0	0	1H/dot	0	1	2H/dot	1	0	3H/dot
VSZ1H1	VSZ1H0	Vertical direction size														
0	0	1H/dot														
0	1	2H/dot														
1	0	3H/dot														
1	1	4H/dot														
D	VSZ1H1	0														
		1														
E	TEST10	0	It should be fixed to "0".													
		1	Test mode													

MITSUBISHI MICROCOMPUTERS  
M35046-XXXSP/FP

SCREEN CHARACTER and PATTERN DISPLAY CONTROLLERS

(7) Address 126<sub>16</sub>

DA	Register	Contents		Remarks												
		Status	Function													
0	LIN10	0	The first line is set by VSZ1L0 and VSZ1L1. The second to 12th lines are set by VSZ2L0 and VSZ2L1.	Character size setting in the vertical direction for the 10th line.												
		1	The first line is set by VSZ1H0 and VSZ1H1. The second to 12th lines are set by VSZ2H0 and VSZ2H1.													
1	LIN11	0	The first line is set by VSZ1L0 and VSZ1L1. The second to 12th lines are set by VSZ2L0 and VSZ2L1.	Character size setting in the vertical direction for the 11th line.												
		1	The first line is set by VSZ1H0 and VSZ1H1. The second to 12th lines are set by VSZ2H0 and VSZ2H1.													
2	LIN12	0	The first line is set by VSZ1L0 and VSZ1L1. The second to 12th lines are set by VSZ2L0 and VSZ2L1.	Character size setting in the vertical direction for the 12th line.												
		1	The first line is set by VSZ1H0 and VSZ1H1. The second to 12th lines are set by VSZ2H0 and VSZ2H1.													
3	LIN13	0	The first line is set by VSZ1L0 and VSZ1L1. The second to 12th lines are set by VSZ2L0 and VSZ2L1.	Character size setting in the vertical direction for the 13th line.												
		1	The first line is set by VSZ1H0 and VSZ1H1. The second to 12th lines are set by VSZ2H0 and VSZ2H1.													
4	LIN14	0	The first line is set by VSZ1L0 and VSZ1L1. The second to 12th lines are set by VSZ2L0 and VSZ2L1.	Character size setting in the vertical direction for the 14th line.												
		1	The first line is set by VSZ1H0 and VSZ1H1. The second to 12th lines are set by VSZ2H0 and VSZ2H1.													
5	LIN15	0	The first line is set by VSZ1L0 and VSZ1L1. The second to 12th lines are set by VSZ2L0 and VSZ2L1.	Character size setting in the vertical direction for the 15th line.												
		1	The first line is set by VSZ1H0 and VSZ1H1. The second to 12th lines are set by VSZ2H0 and VSZ2H1.													
6	LIN16	0	The first line is set by VSZ1L0 and VSZ1L1. The second to 12th lines are set by VSZ2L0 and VSZ2L1.	Character size setting in the vertical direction for the 16th line.												
		1	The first line is set by VSZ1H0 and VSZ1H1. The second to 12th lines are set by VSZ2H0 and VSZ2H1.													
7	LIN17	0	The first line is set by VSZ1L0 and VSZ1L1. The second to 12th lines are set by VSZ2L0 and VSZ2L1.	Character size setting in the vertical direction for the 17th line.												
		1	The first line is set by VSZ1H0 and VSZ1H1. The second to 12th lines are set by VSZ2H0 and VSZ2H1.													
8	V18SZ0	0	H: Cycle with the horizontal synchronizing pulse	Character size setting in the vertical direction for the 18th line. (display monitor 1 to 12 line)												
		1	<table border="1"> <thead> <tr> <th>V18SZ1</th> <th>V18SZ0</th> <th>Vertical direction size</th> </tr> </thead> <tbody> <tr> <td>0</td> <td>0</td> <td>1H/dot</td> </tr> <tr> <td>0</td> <td>1</td> <td>2H/dot</td> </tr> <tr> <td>1</td> <td>0</td> <td>3H/dot</td> </tr> <tr> <td>1</td> <td>1</td> <td>4H/dot</td> </tr> </tbody> </table>		V18SZ1	V18SZ0	Vertical direction size	0	0	1H/dot	0	1	2H/dot	1	0	3H/dot
V18SZ1	V18SZ0	Vertical direction size														
0	0	1H/dot														
0	1	2H/dot														
1	0	3H/dot														
1	1	4H/dot														
9	V18SZ1	0														
		1														
A	VSZ2L0	0	H: Cycle with the horizontal synchronizing pulse	Character size setting in the vertical direction (display monitor for 2 to 12 line) at "0" state in register LIN2 to LIN17.												
		1	<table border="1"> <thead> <tr> <th>VSZ2L1</th> <th>VSZ2L0</th> <th>Vertical direction size</th> </tr> </thead> <tbody> <tr> <td>0</td> <td>0</td> <td>1H/dot</td> </tr> <tr> <td>0</td> <td>1</td> <td>2H/dot</td> </tr> <tr> <td>1</td> <td>0</td> <td>3H/dot</td> </tr> <tr> <td>1</td> <td>1</td> <td>4H/dot</td> </tr> </tbody> </table>		VSZ2L1	VSZ2L0	Vertical direction size	0	0	1H/dot	0	1	2H/dot	1	0	3H/dot
VSZ2L1	VSZ2L0	Vertical direction size														
0	0	1H/dot														
0	1	2H/dot														
1	0	3H/dot														
1	1	4H/dot														
B	VSZ2L1	0														
		1														
C	VSZ2H0	0	H: Cycle with the horizontal synchronizing pulse	Character size setting in the vertical direction (display monitor for 2 to 12 line) at "1" state in register LIN2 to LIN17.												
		1	<table border="1"> <thead> <tr> <th>VSZ2H1</th> <th>VSZ2H0</th> <th>Vertical direction size</th> </tr> </thead> <tbody> <tr> <td>0</td> <td>0</td> <td>1H/dot</td> </tr> <tr> <td>0</td> <td>1</td> <td>2H/dot</td> </tr> <tr> <td>1</td> <td>0</td> <td>3H/dot</td> </tr> <tr> <td>1</td> <td>1</td> <td>4H/dot</td> </tr> </tbody> </table>		VSZ2H1	VSZ2H0	Vertical direction size	0	0	1H/dot	0	1	2H/dot	1	0	3H/dot
VSZ2H1	VSZ2H0	Vertical direction size														
0	0	1H/dot														
0	1	2H/dot														
1	0	3H/dot														
1	1	4H/dot														
D	VSZ2H1	0														
		1														
E	TEST11	0	It should be fixed to "0".													
		1	Test mode													

SCREEN CHARACTER and PATTERN DISPLAY CONTROLLERS

(8) Address 127<sub>16</sub>

DA	Register	Contents				Remarks		
		Status	Function					
0	RR	0	RB	RG	RR	Color	Sets the color of all blankings.	
		1	0	0	0	Black		
1	RG	0	0	0	1	Red		
		1	0	1	0	Green		
2	RB	0	0	1	1	Yellow		
		1	1	0	0	Blue		
3	FR	0	1	0	1	Magenta		
		1	1	1	0	Cyan		
4	FG	0	1	1	1	White		
		1	0	0	0	Black		
5	FB	0	0	0	0	Black		Sets the blanking color of the Border size, or the shadow size.
		1	0	0	1	Red		
6	TEST6	0	0	1	0	Green		
		1	0	1	1	Yellow		
7	TEST7	0	1	0	0	Blue		
		1	1	0	1	Magenta		
8	TEST8	0	1	1	0	Cyan		
		1	1	1	1	White		
9	BETA14	0	Matrix-outline display (12 × 18 dot)			Set this register to the character font set by display RAM BR, BG and BB.		
		1	Matrix-outline display (14 × 18 dot)					
A	HSZ10	0	T: Display frequency cycle			Character size setting in the horizontal direction for the first line.		
		1	HSZ11	HSZ10	Horizontal direction size			
B	HSZ11	0	0	0	1T/dot			
		1	0	1	2T/dot			
C	HSZ20	0	1	0	3T/dot			
		1	1	1	4T/dot			
D	HSZ21	0	0	0	1T/dot			
		1	0	1	2T/dot			
E	TEST12	0	1	0	3T/dot	Character size setting in the horizontal direction for the 2nd line to 12th line.		
		1	1	1	4T/dot			
6	TEST6	0	It should be fixed to "0".					
		1	Can not be used.					
7	TEST7	0	It should be fixed to "0".					
		1	Can not be used.					
8	TEST8	0	It should be fixed to "0".					
		1	Can not be used.					
A	HSZ10	0	T: Display frequency cycle			Character size setting in the horizontal direction for the first line.		
		1	HSZ11	HSZ10	Horizontal direction size			
B	HSZ11	0	0	0	1T/dot			
		1	0	1	2T/dot			
C	HSZ20	0	1	0	3T/dot			
		1	1	1	4T/dot			
D	HSZ21	0	0	0	1T/dot	Character size setting in the horizontal direction for the 2nd line to 12th line.		
		1	0	1	2T/dot			
E	TEST12	0	1	0	3T/dot			
		1	1	1	4T/dot			
6	TEST6	0	It should be fixed to "0".					
		1	Can not be used.					
7	TEST7	0	It should be fixed to "0".					
		1	Can not be used.					
8	TEST8	0	It should be fixed to "0".					
		1	Can not be used.					

MITSUBISHI MICROCOMPUTERS  
M35046-XXXSP/FP

SCREEN CHARACTER and PATTERN DISPLAY CONTROLLERS

(9) Address 128<sub>16</sub>

DA	Register	Contents		Remarks																			
		Status	Function																				
0	BCOL	0	Blanking of BLK0, BLK1	Sets all raster blanking																			
		1	All raster blanking																				
1	B/F	0	Synchronize with the leading edge of horizontal synchronization.	Synchronize with the front porch or back porch of the horizontal synchronazation signal.																			
		1	Synchronize with the trailing edge of horizontal synchronization.																				
2	VMASK	0	Do not mask by VERT input signal	This register has or do not have mask at phase comparison operating.																			
		1	Mask by VERT input signal																				
3	POLV	0	VERT pin is negative polarity	Set VERT pin polarity.																			
		1	VERT pin is positive polarity																				
4	POLH	0	HOR pin is negative polarity	Set HOR pin polarity.																			
		1	HOR pin is positive polarity																				
5	BLK0	0	<table border="1"> <thead> <tr> <th colspan="2">BLK</th> <th rowspan="2">Blanking mode</th> </tr> </thead> <tbody> <tr> <td>1</td> <td>0</td> <td rowspan="2">Matrix-outline size</td> </tr> <tr> <td>0</td> <td>0</td> </tr> <tr> <td>0</td> <td>1</td> <td>Character size</td> </tr> <tr> <td>1</td> <td>0</td> <td>Border size</td> </tr> <tr> <td>6</td> <td>BLK1</td> <td>0</td> <td>1</td> <td>Matrix-outline size</td> </tr> </tbody> </table>	BLK		Blanking mode	1	0	Matrix-outline size	0	0	0	1	Character size	1	0	Border size	6	BLK1	0	1	Matrix-outline size	Set blanking mode. (Note 1) An example of blanking mode at BCOL = "0", DSPn = "0" (n = 0 to 11) shown left.
BLK		Blanking mode																					
1	0			Matrix-outline size																			
0	0																						
0	1	Character size																					
1	0	Border size																					
6	BLK1	0	1	Matrix-outline size																			
1	1																						
0	0																						
1	1																						
7	SYAD	0	Border display of character	(Note 2)																			
		1	Shadow display of character																				
8	RAMERS	0	RAM not erased	There is no need to reset because there is no register for this bit.																			
		1	RAM erased																				
9	STOP	0	Oscillation of clock for display	R, G, B and BLNK0 output can be altered.																			
		1	Stop the oscillation of clock for display																				
A	DSPON	0	Display OFF	Display can be altered.																			
		1	Display ON																				
B	BLINK0	0	<table border="1"> <thead> <tr> <th colspan="2">BLINK</th> <th rowspan="2">Duty</th> </tr> </thead> <tbody> <tr> <td>1</td> <td>0</td> <td rowspan="2">Blinking OFF</td> </tr> <tr> <td>0</td> <td>0</td> </tr> <tr> <td>0</td> <td>1</td> <td>25%</td> </tr> <tr> <td>1</td> <td>0</td> <td>50%</td> </tr> <tr> <td>C</td> <td>BLINK1</td> <td>0</td> <td>1</td> <td>75%</td> </tr> </tbody> </table>	BLINK		Duty	1	0	Blinking OFF	0	0	0	1	25%	1	0	50%	C	BLINK1	0	1	75%	Blinking duty ratio can be altered.
		BLINK		Duty																			
1	0	Blinking OFF																					
0	0																						
0	1	25%																					
1	0	50%																					
C	BLINK1	0	1	75%																			
1	1																						
0	0																						
1	1																						
D	BLINK2	0	Divided into 64 of vertical synchronous signal	Blinking frequency can be altered.																			
		1	Divided into 32 of vertical synchronous signal																				
E	TEST13	0	It should be fixed to "0".																				
		1	Test mode																				

**REGISTER SUPPLEMENTARY DESCRIPTION**

(1) Setting external clock input mode (by use of EXCK0 (120<sub>16</sub>) and EXCK1 (123<sub>16</sub>))

Two modes given below are available for the external clock signal input. (the settings (EXCK1, EXCK0) = (0, 1), (1, 0) are forbidden.)

(a) When (EXCK1, EXCK0) = (0, 0), Fosc = 20 to 30 MHz

Input from the TCK pin a constant-period continuous external clock that synchronizes with the horizontal synchronization signal. And input from HOR pin a constant-period continuous horizontal synchronous signal.

Never stop inputting the clock while displaying.

Do not have to set a display frequency because the clock just as it is entered from outside is used as the display clock.

(b) When (EXCK1, EXCK0) = (1, 1), Fosc = 20 to 80 MHz

Input from the TCK pin a constant-period continuous external clock that synchronizes with the horizontal synchronization signal.

Never stop inputting the clock while displaying.

Be sure to set a display frequency because the internal clock made to synchronize with the clock input from outside is used as the display clock (see the next page).

(Example for input)

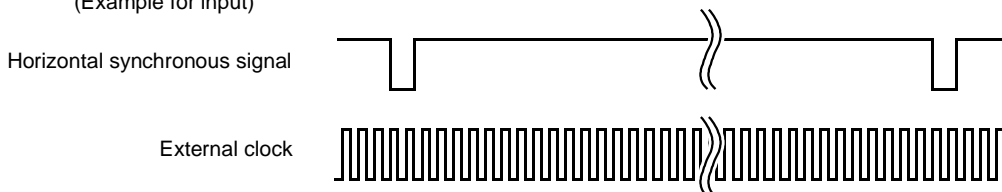

SCREEN CHARACTER and PATTERN DISPLAY CONTROLLERS

(2) Setting display frequencies

Set a display frequency by setting a frequency value for the horizontal synchronization signal by use of DIV10 to DIV0 (120<sub>16</sub>).

Set display frequency area in conformity with the frequency of the external clock signal.

Set display frequency area by use of DIVS0, DIVS1 (120<sub>16</sub>), RSEL0 (121<sub>16</sub>), and RSEL1 (122<sub>16</sub>). Frequency area are as follows.

RSEL1	RSEL0	DIVS1	DIVS0	Display frequency area
0	1	0	0	70.0 to 80.0
0	0	0	0	63.0 to 70.0
1	0	0	1	56.6 to 63.0
0	1	0	1	46.6 to 56.6
0	0	0	1	45.0 to 46.6
1	0	1	0	42.5 to 45.0
0	1	1	0	35.0 to 42.5
0	0	1	0	31.5 to 35.0
1	0	1	1	28.3 to 31.5
0	1	1	1	23.3 to 28.3
0	0	1	1	20.0 to 23.3

Cautions in setting a display frequency

To change the external clock frequency or the horizontal synchronization frequency, follow the steps in sequence given below.

- (a) Display OFF (DSPON = 0)
- (b) Set the display frequency (Use DIV10 to DIV0 (120<sub>16</sub>), DIVS0, DIVS1 (120<sub>16</sub>), RSEL0 (121<sub>16</sub>), and RSEL1 (122<sub>16</sub>).
- (c) 20-ms waiting time with the horizontal synchronization signal and the external clock signal being input
- (d) Display ON (DSPON = 1)

## DISPLAY FORM1

Table 1 shows display form of blanking.

**Table 1. Display mode**

BCOL	Standard blanking		When the all of registers DSPn (Note 2) are set to "0"	When some of registers DSPn are set to "1"		BLNK0 output
	BLK1	BLK0		DSPn = 0	DSPn = 1	
0	0	0	Matrix-outline and border display. color set: FR, FG, FB or display RAM (Note 4)	Matrix-outline and border display. color set: FR, FG, FB or display RAM (Note 4)	Matrix-outline display color set: display RAM (Note 3)	DSPn = "0" line } DSPn = "1" line } Matrix-outline size
	0	1	Character	Character	Border display color set: display RAM (Note 3)	DSPn = "0" line → Character size DSPn = "1" line → Border size
	1	0	Border display color set: display RAM (Note 3)	Border display color set: display RAM (Note 3)	Matrix-outline display color set: display RAM (Note 3)	DSPn = "0" line → Border size DSPn = "1" line → Matrix-outline size
	1	1	Matrix-outline display color set: display RAM (Note 3)	Matrix-outline display color set: display RAM (Note 3)	Character	DSPn = "0" line → Matrix-outline size DSPn = "1" line → Character size
1 (Note 1)	0	0	Matrix-outline and border display. color set: FR, FG, FB or display RAM (Note 4)	Matrix-outline and border display. color set: FR, FG, FB or display RAM (Note 4)	Matrix-outline display color set: display RAM (Note 3)	All blanking size
	0	1	Character	Character	Border display color set: display RAM (Note 3)	
	1	0	Border display color set: display RAM (Note 3)	Border display color set: display RAM (Note 3)	Matrix-outline display color set: display RAM (Note 3)	
	1	1	Matrix-outline display color set: display RAM (Note 3)	Matrix-outline display color set: display RAM (Note 3)	Character	

Notes 1: Color setting of raster area is set by register RR, RG and RB.

2: DSPn (n = 0 to 11)

3: Set by BR, BG and BB of display RAM.

4: Set border by register FR, FG and FB. Set matrix-outline by BR, BG and BB of display RAM.



**DISPLAY FORM 2**

M35046-XXXSP/FP has the following four display forms.

- (1) Character size  
: Blanking same as the character size.
- (2) Border size  
: Blanking the background as a size from character.
- (3) Matrix-outline size  
: Blanking the background 12 × 18 dot.  
When set register BETA14 to "1", setting of blanking the background 14 × 18 dot is possible.
- (4) All blanking size  
: When set register BCOL to "1", all raster area is blanking.

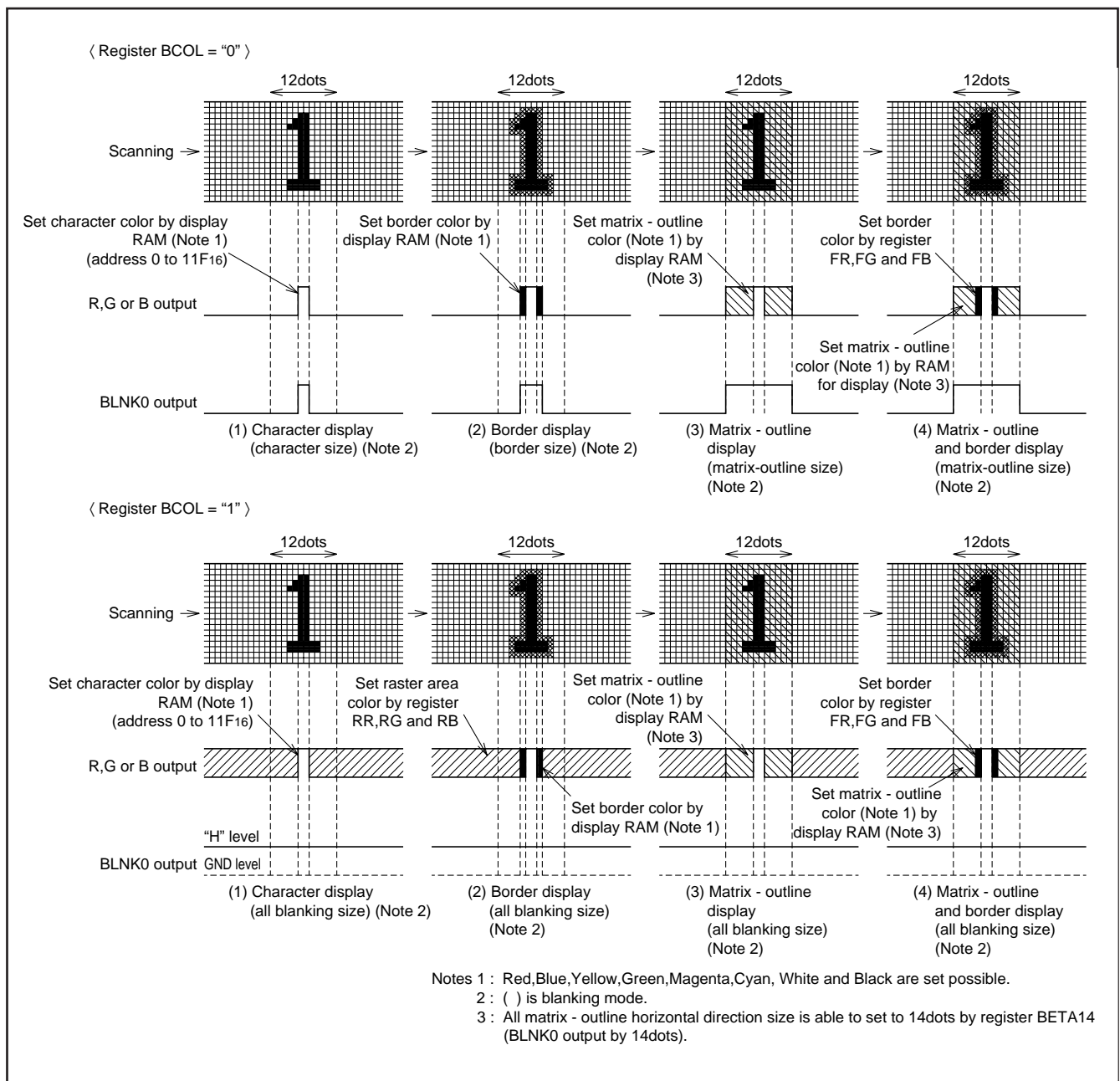

Fig. 3 Display form

### DISPLAY FORM 3

When border display mode, if set SYAD = "0" to "1", it change to shadow display mode.

Border and shadow display are shown below.

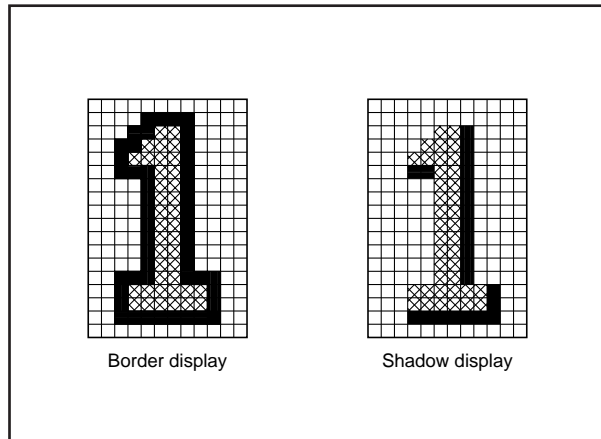

Fig. 4 Border and shadow display

Set shadow display color by display RAM or register FR, FG and FB.

**DATA INPUT EXAMPLE**

Data of display RAM and display control registers can be set by the serial input function. Example of data setting is shown in Figure 5 and Figure 6.

(1) At EXCK0 = "0", EXCK1 = "0" setting

		DAF	DAE	DAD	DAC	DAB	DAA	DA9	DA8	DA7	DA6	DA5	DA4	DA3	DA2	DA1	DA0	Addition
		200 msec hold																System set-up
1	address 120 <sub>16</sub>	0	0	0	0	0	0	0	1	0	0	1	0	0	0	0	0	Address set
2	data 120 <sub>16</sub>	0	0	1	0	0	0	0	0	0	0	0	0	0	0	0	0	(Note 1)
3	data 121 <sub>16</sub>	0	0	PTD7	PTD6	1	PTD4	1	PTD2	1	1	1	0	1	0	1	1	Output setting
4	data 122 <sub>16</sub>	0	0	0	0	0	0	HP9	HP8	HP7	HP6	HP5	HP4	HP3	HP2	HP1	HP0	Horizontal display location setting
5	data 123 <sub>16</sub>	0	0	0	0	0	0	VP9	VP8	VP7	VP6	VP5	VP4	VP3	VP2	VP1	VP0	Vertical display location setting
6	data 124 <sub>16</sub>	0	0	0	0	0	0	0	0	0	0	0	0	0	0	0	0	Display form setting
7	data 125 <sub>16</sub>	0	0	0	0	0	0	0	0	0	0	0	0	0	0	0	0	Character size setting
8	data 126 <sub>16</sub>	0	0	0	0	0	0	0	0	0	0	0	0	0	0	0	0	Character size setting
9	data 127 <sub>16</sub>	0	0	0	0	0	0	0	0	0	0	0	0	0	0	0	0	Color, character size setting
10	data 128 <sub>16</sub>	0	0	0	0	0	0	0	1	0	1	1	POLH	POLV	0	0	0	Display OFF, display form (Note 2)
11	data 000 <sub>16</sub>	0	BB	BG	BR	BLINK	B	G	R	C7	C6	C5	C4	C3	C2	C1	C0	
12 ⋮ ⋮ ⋮ 297	⋮ ⋮ ⋮ ⋮ ⋮	⋮ ⋮ ⋮ ⋮ ⋮	Character background color			Blinking	Character color			Character code								Character setting
298	data 11F <sub>16</sub>	0	BB	BG	BR	BLINK	B	G	R	C7	C6	C5	C4	C3	C2	C1	C0	
299	address 128 <sub>16</sub>	0	0	0	0	0	0	0	1	0	0	1	0	1	0	0	0	Address setting
300	data 128 <sub>16</sub>	0	0	0	0	0	1	0	0	0	1	1	POLH	POLV	0	0	0	Display ON, display form (Note 2)

Notes 1 : Input the horizontal synchronous signal to the HOR pin and the vertical synchronous signal to the VERT pin. If serrated pulses are present in the vertical synchronous signal, set the register VMASK to 1.  
 2 : Matrix-outline display in this data.

Fig. 5 Example of data setting by the serial input function (1)

SCREEN CHARACTER and PATTERN DISPLAY CONTROLLERS

(2) At EXCK0 = "1", EXCK1 = "1" setting

		DAF	DAE	DAD	DAC	DAB	DAA	DA9	DA8	DA7	DA6	DA5	DA4	DA3	DA2	DA1	DA0	Addition
		200 msec hold															System set-up	
1	address 120 <sub>16</sub>	0	0	0	0	0	0	0	1	0	0	1	0	0	0	0	0	Address set
2	data 120 <sub>16</sub>	0	1	1	DIVS1	DIVS0	DIV10	DIV9	DIV8	DIV7	DIV6	DIV5	DIV4	DIV3	DIV2	DIV1	DIV0	Set frequency value of horizontal synchronous frequency(Note 1)
3	data 121 <sub>16</sub>	0	RSEL0	PTD7	PTD6	1	PTD4	1	PTD2	1	1	1	0	1	0	1	1	Output setting Oscillation circuit setting
4	data 122 <sub>16</sub>	0	RSEL1	0	0	0	0	HP9	HP8	HP7	HP6	HP5	HP4	HP3	HP2	HP1	HP0	Horizontal display location setting Oscillation circuit setting
5	data 123 <sub>16</sub>	0	1	0	0	0	0	VP9	VP8	VP7	VP6	VP5	VP4	VP3	VP2	VP1	VP0	Vertical display location setting
6	data 124 <sub>16</sub>	0	1	0	0	0	0	0	0	0	0	0	0	0	0	0	0	Display form setting
7	data 125 <sub>16</sub>	0	0	0	0	0	0	0	0	0	0	0	0	0	0	0	0	Character size setting
8	data 126 <sub>16</sub>	0	0	0	0	0	0	0	0	0	0	0	0	0	0	0	0	Character size setting
9	data 127 <sub>16</sub>	0	0	0	0	0	0	0	0	0	0	0	0	0	0	0	0	Color, character size setting
10	data 128 <sub>16</sub>	0	0	0	0	0	0	0	1	0	1	1	POLH	POLV	0	0	0	Display OFF, display form (Note 2)
		Hold the time length as 1V of vertical synchronous signal																
11	data 000 <sub>16</sub>	0	BB	BG	BR	BLINK	B	G	R	C7	C6	C5	C4	C3	C2	C1	C0	Character setting
12 ⋮ ⋮ ⋮ 297	⋮ ⋮ ⋮ ⋮ ⋮	⋮ ⋮ ⋮ ⋮ ⋮	Character background color			BLINK-ING	Character color			Character code								
298	data 11F <sub>16</sub>	0	BB	BG	BR	BLINK	B	G	R	C7	C6	C5	C4	C3	C2	C1	C0	
299	address 128 <sub>16</sub>	0	0	0	0	0	0	0	1	0	0	1	0	1	0	0	0	
300	data 128 <sub>16</sub>	0	0	0	0	0	1	0	0	0	1	1	POLH	POLV	0	0	0	Display ON, display form (Note 2)

Notes 1 : From this time, input clock to TCK pin. And, input the horizontal synchronous signal to the HOR pin and the vertical synchronous signal to the VERT pin. If serrated pulses are present in the vertical synchronous signal, set the register VMASK to 1.  
2 : Matrix-outline display in this data.

Fig. 6 Example of data setting by the serial input function (2)

### SERIAL DATA INPUT TIMING

- (1) Serial data should be input with the LSB first.
- (2) The address consists of 16 bits.
- (3) The data consists of 16 bits.
- (4) The 16 bits in the SCK after the  $\overline{CS}$  signal has fallen are the address, and for succeeding input data, the address is incremented every 16 bits. Therefore, it is not necessary to input the address from the second data.

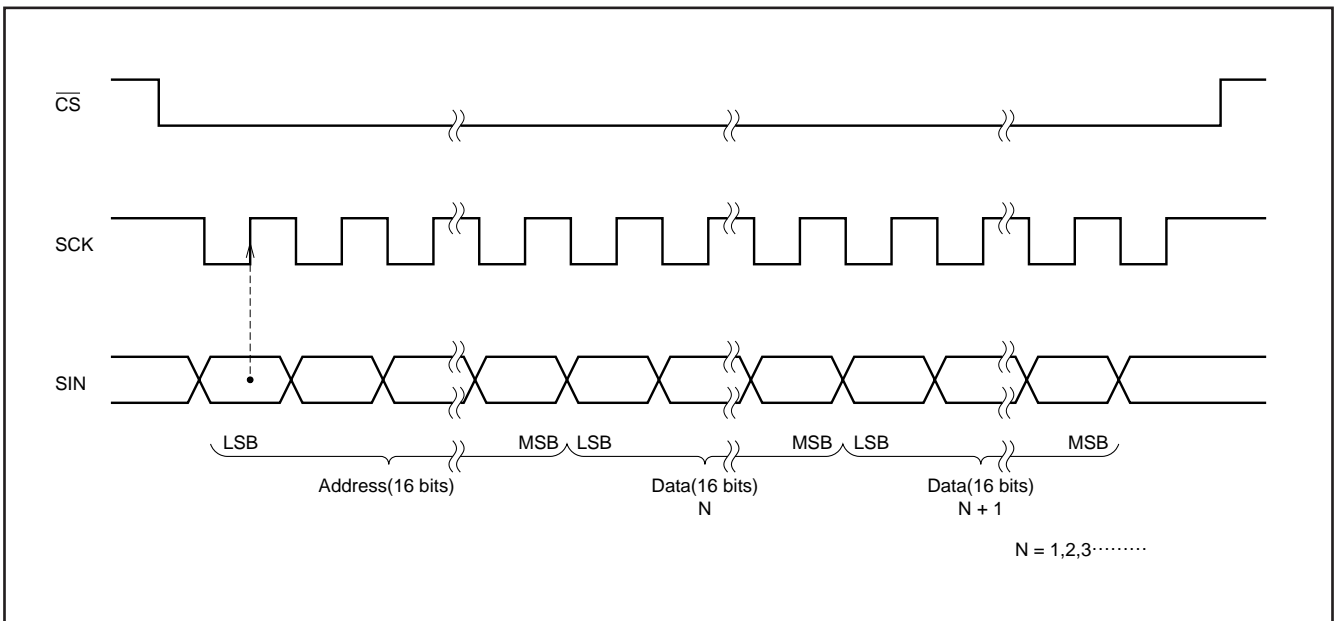

Fig. 7 Serial input timing

### CHARACTER FONT

Images are composed on a  $12 \times 18$  dot matrix, and characters can be linked vertically and horizontally with other characters to allow the display the continuous symbols.

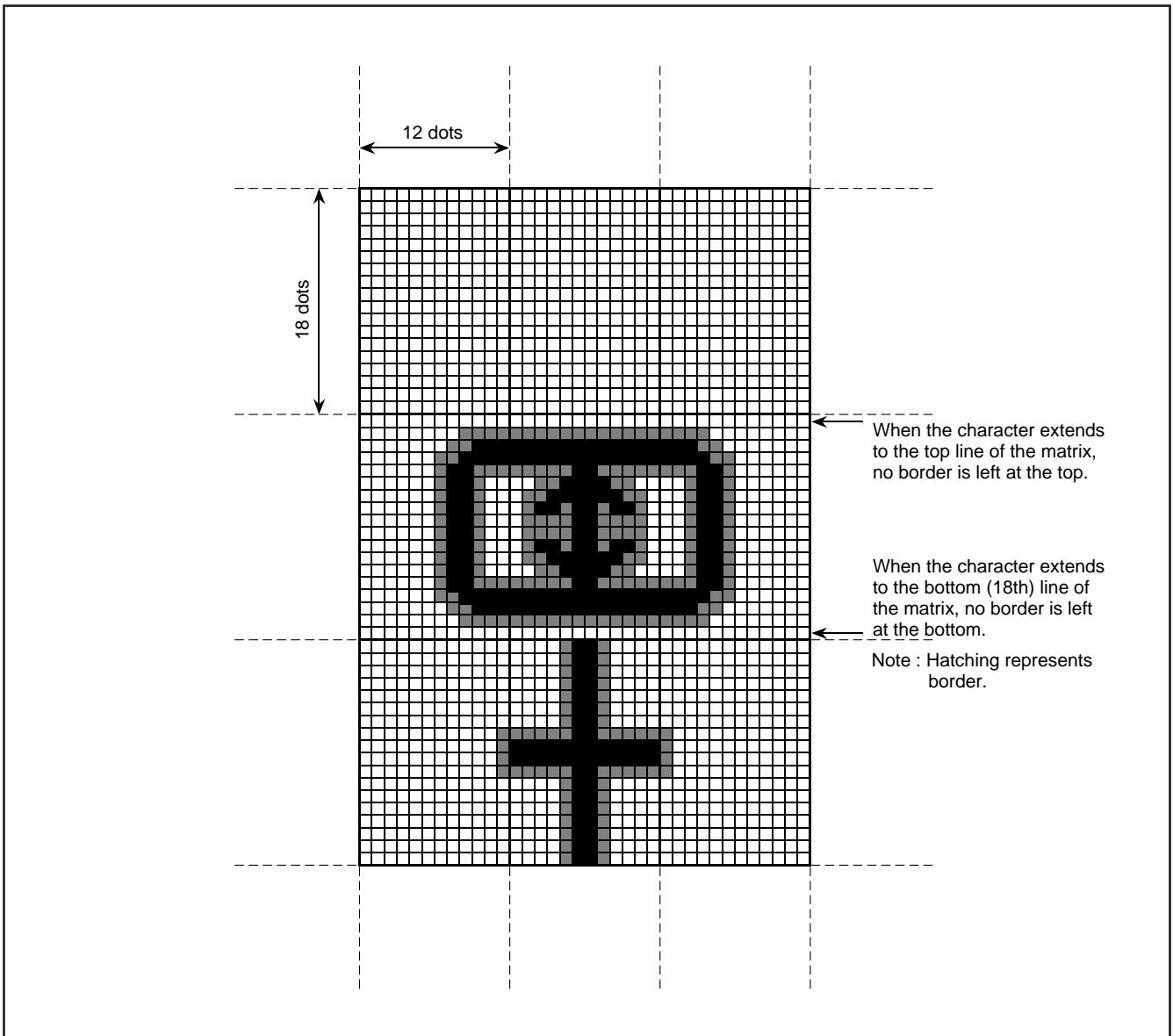

Fig. 8 Example for displaying a continuous pattern after combining characters in the horizontal or vertical direction

Character code FF<sub>16</sub> is fixed as a blank without background.  
Therefore, cannot register a character font in this code.

**TIMING REQUIREMENTS** ( $T_a = -20^{\circ}\text{C}$  to  $+85^{\circ}\text{C}$ ,  $V_{DD} = 5 \pm 0.25\text{V}$ , unless otherwise noted)

Symbol	Parameter	Limits			Unit	Remarks
		Min.	Typ.	Max.		
$t_w(\text{SCK})$	SCK width	200	—	—	ns	See Figure 9
$t_{su}(\overline{\text{CS}})$	$\overline{\text{CS}}$ setup time	200	—	—	ns	
$t_h(\overline{\text{CS}})$	$\overline{\text{CS}}$ hold time	2	—	—	$\mu\text{s}$	
$t_{su}(\text{SIN})$	SIN setup time	200	—	—	ns	
$t_h(\text{SIN})$	SIN hold time	200	—	—	ns	
$t_{word}$	1 word writing time	10	—	—	$\mu\text{s}$	

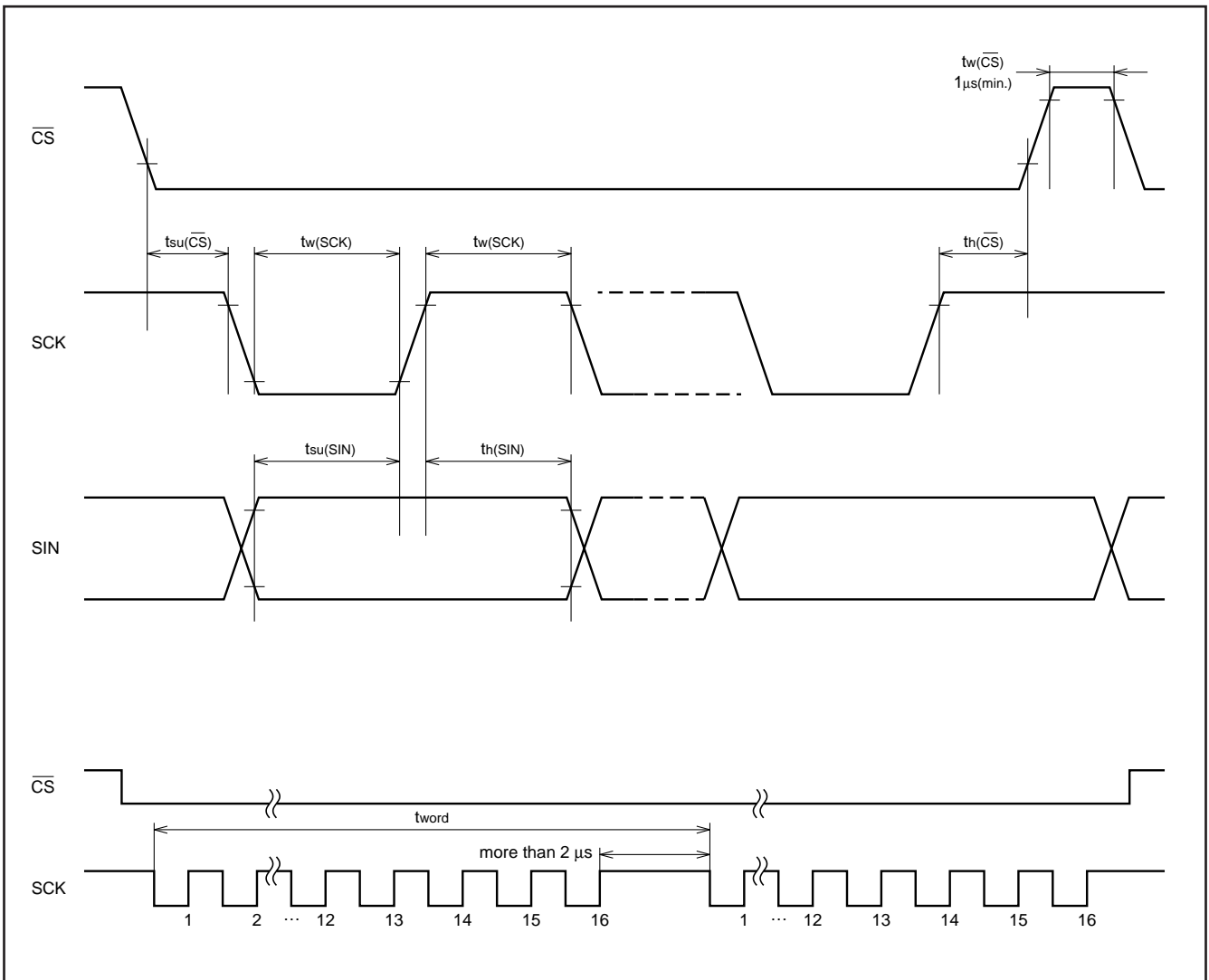

Fig. 9 Serial input timing requirements





SCREEN CHARACTER and PATTERN DISPLAY CONTROLLERS

**ABSOLUTE MAXIMUM RATINGS**

Symbol	Parameter	Conditions	Ratings	Unit
VDD	Supply voltage	With respect to VSS.	-0.3 to +6.0	V
Vi	Input voltage		$V_{SS} - 0.3 \leq V_i \leq V_{DD} + 0.3$	V
Vo	Output voltage		$V_{SS} \leq V_o \leq V_{DD}$	V
Pd	Power dissipation	Ta = 25°C	300	mW
Topr	Operating temperature		-20 to +85	°C
Tstg	Storage temperature		-40 to +125	°C

**RECOMMENDED OPERATING CONDITIONS** (VDD = 5V, Ta = -20 to +85°C, unless otherwise noted)

Symbol	Parameter	Limits			Unit
		Min.	Typ.	Max.	
VDD	Supply voltage	4.75	5.0	5.25	V
VIH	"H" level input voltage SIN, SCK, $\overline{CS}$ , $\overline{AC}$ HOR, VERT	0.8VDD	VDD	VDD	V
VIL	"L" level input voltage SIN, SCK, $\overline{CS}$ , $\overline{AC}$ HOR, VERT	0	0	0.2VDD	V
FOSC	Oscillating frequency for display	20.0	—	80.0	MHz
Hsync	Horizontal synchronous signal input frequency	15.0	—	130.0	kHz

**ELECTRICAL CHARACTERISTICS** (VDD = 5V, Ta = 25°C, unless otherwise noted)

Symbol	Parameter	Test conditions	Limits			Unit
			Min.	Typ.	Max.	
VDD	Supply voltage	Ta = -20 to +85°C	4.75	5.0	5.25	V
IDD	Supply current	VDD = 5.25V	—	30	50	mA
VOH	"H" level output voltage	P0 to P7	3.5	—	—	V
		CPOUT				
VOL	"L" level output voltage	P0 to P7	—	—	0.4	V
		CPOUT				
Ri	Pull-up resistance SCK, $\overline{AC}$ , $\overline{CS}$ , SIN	VDD = 5.0V	10	30	100	kΩ
VTCK	External clock input width	4.75V < VDD ≤ 5.25V	0.7VDD	—	0.9VDD	VPP

### NOTE FOR SUPPLYING POWER

Timing of power supplying to  $\overline{AC}$  pin

The internal circuit of M35046-XXXSP/FP is reset when the level of the auto clear input pin  $\overline{AC}$  is "L". This pin is hysteresis input with the pull-up resistor. The timing about power supplying of  $\overline{AC}$  pin is shown in Figure 11.

Timing of power supplying to  $V_{DD1}$  and  $V_{DD2}$ .

Supply power to  $V_{DD1}$  and  $V_{DD2}$  at the same time.

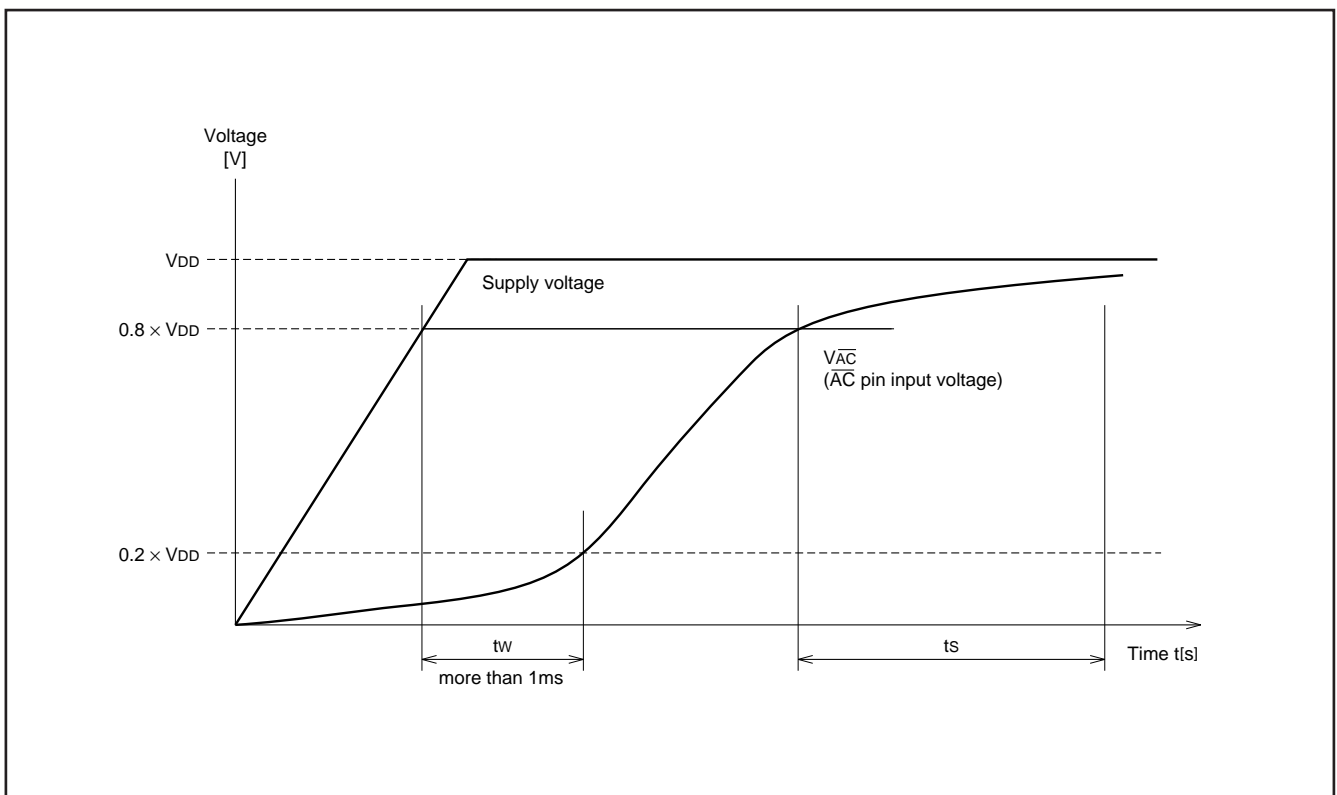

Fig. 11 Timing of power supplying to  $\overline{AC}$  pin

After supplying the power ( $V_{DD}$  and  $V_{SS}$ ) to M35046-XXXSP/FP and the supply voltage becomes more than  $0.8 \times V_{DD}$ , it needs to keep  $V_{IL}$  time;  $t_w$  of the  $\overline{AC}$  pin for more than 1ms.

Start inputting from microcomputer after  $\overline{AC}$  pin supply voltage becomes more than  $0.8 \times V_{DD}$  and keeping 200ms wait time.

### PRECAUTION FOR USE

#### Notes on noise and latch-up

In order to avoid noise and latch-up, connect a bypass capacitor ( $\approx 0.1\mu\text{F}$ ) directly between the  $V_{DD1}$  pin and  $V_{SS}$  pin, and the  $V_{DD2}$  pin and  $V_{SS}$  pin using a heavy wire.

### DATA REQUIRED FOR MASK ROM ORDERING

Please send the following data for mask orders.

- (1) M35046-XXXSP/FP mask ROM order confirmation form
- (2) 20P4B mask specification form
- (3) 20P2Q-A mask specification form
- (4) ROM data (EPROM 3 sets)
- (5) Floppy disks containing the character font generating program + character data

**STANDARD ROM TYPE : M35046-001SP/FP**

M35046-001SP/FP is a standard ROM type of M35046-XXXSP/FP.

The character patterns are fixed to the contents of Figure 12 to 15.

SCREEN CHARACTER and PATTERN DISPLAY CONTROLLERS

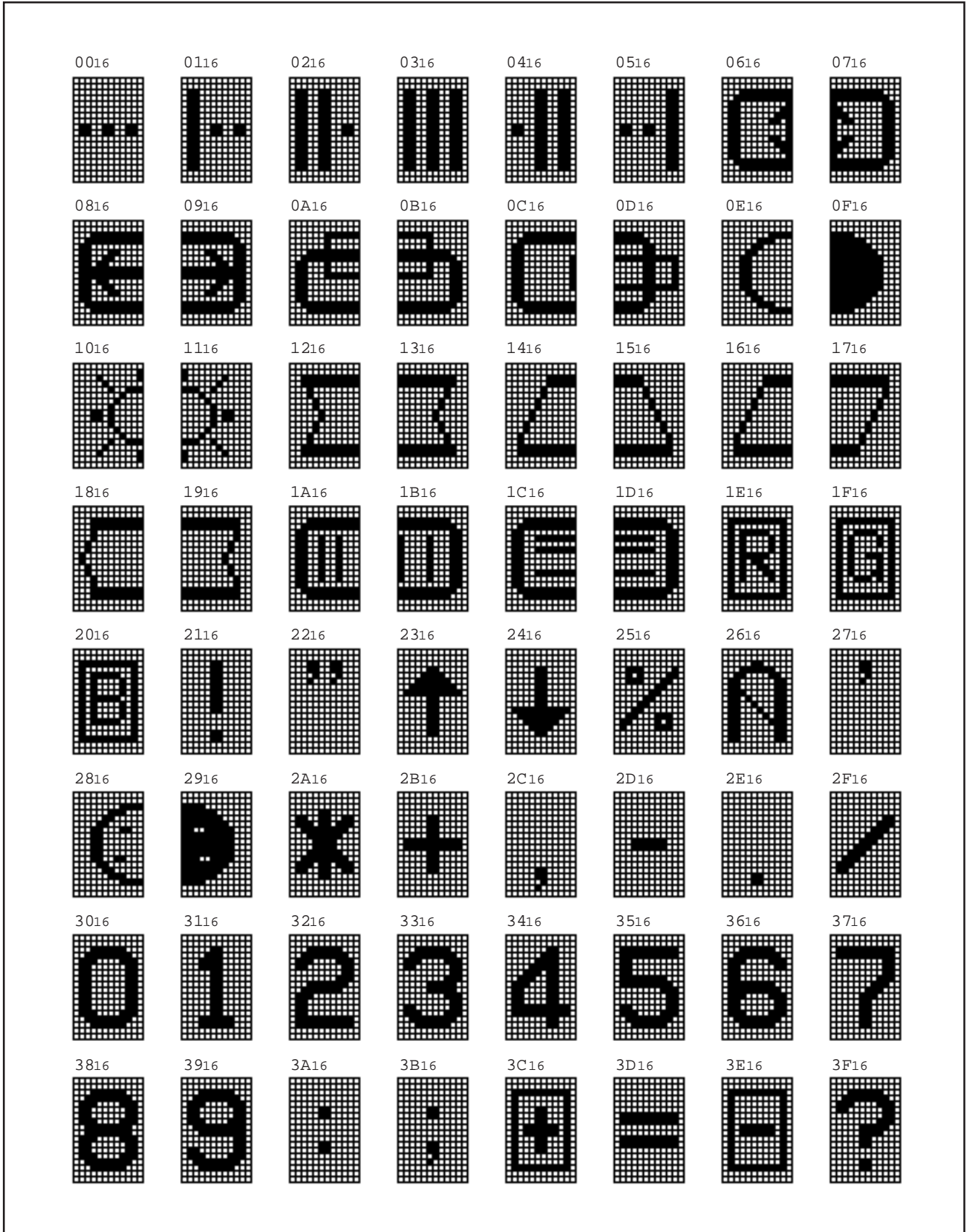

Fig. 12 M35046-001SP/FP character pattern (1)

SCREEN CHARACTER and PATTERN DISPLAY CONTROLLERS



Fig. 13 M35046-001SP/FP character pattern (2)

SCREEN CHARACTER and PATTERN DISPLAY CONTROLLERS

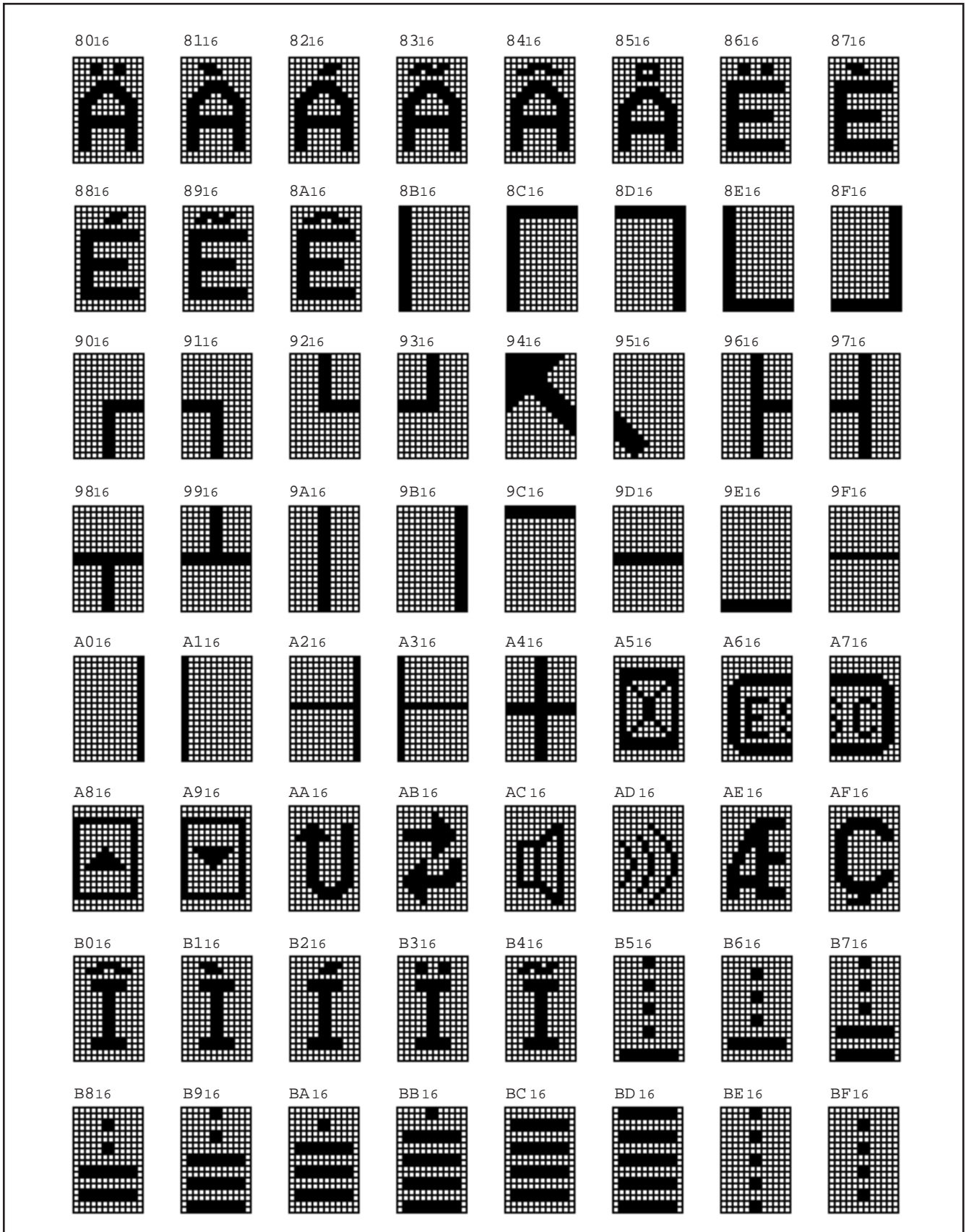

Fig. 14 M35046-001SP/FP character pattern (3)

SCREEN CHARACTER and PATTERN DISPLAY CONTROLLERS

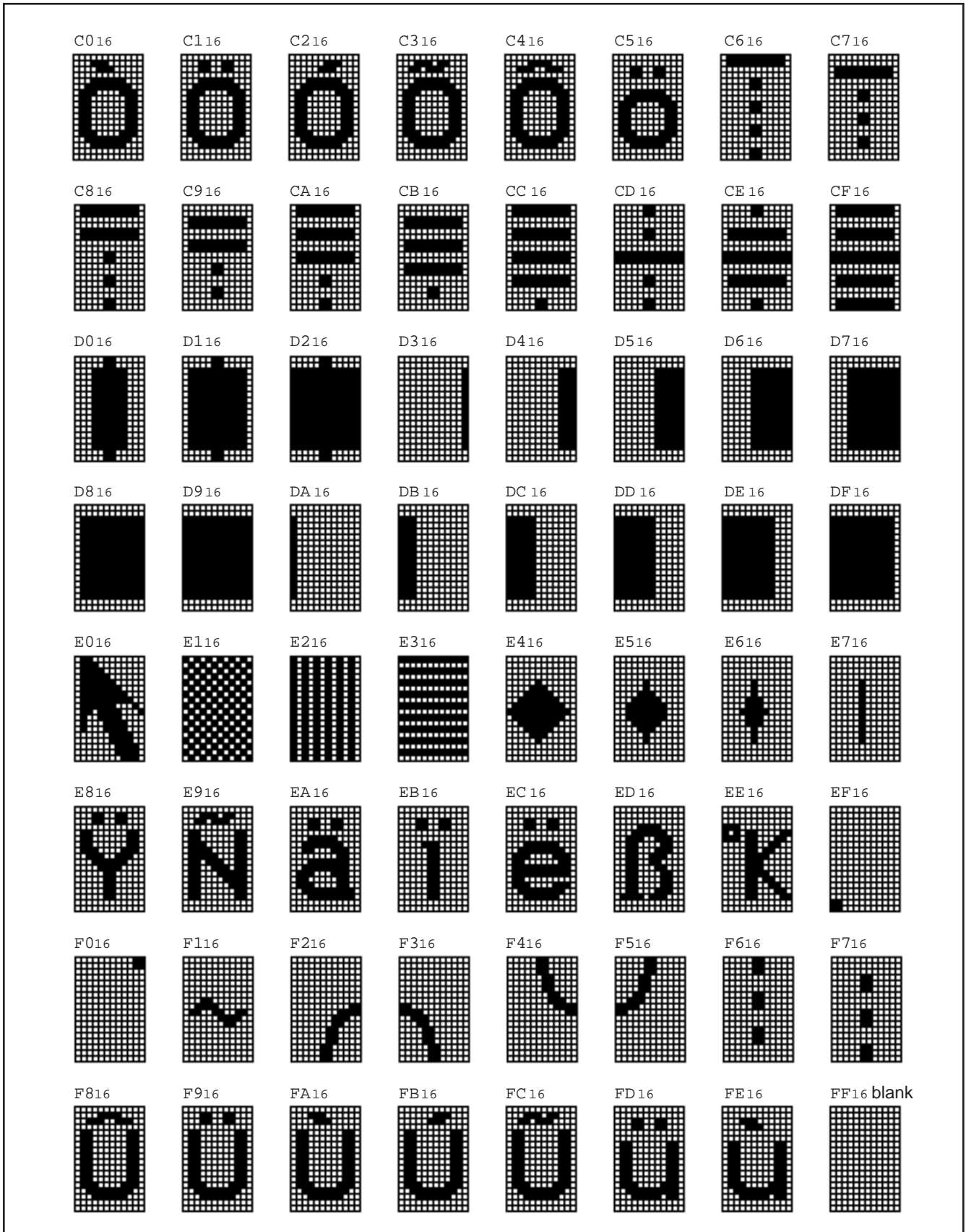
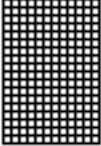
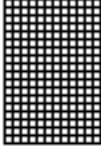
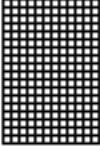
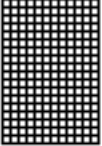
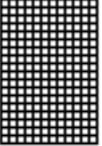
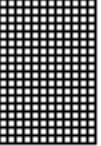
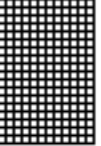
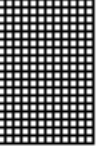
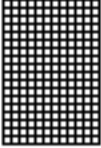
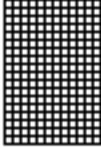
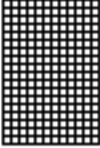
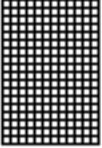
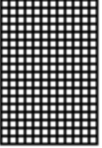
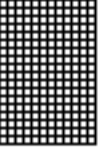
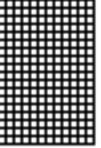
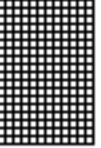
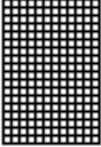
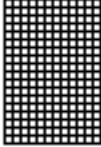
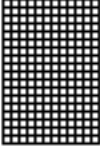
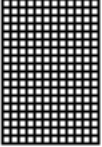
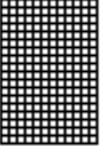
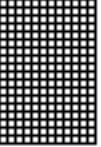
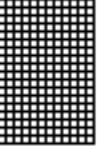
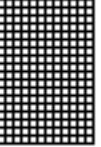
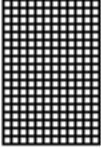
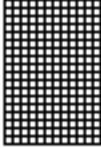
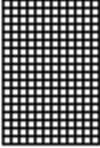
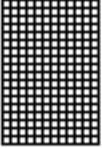
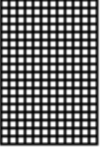
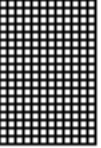
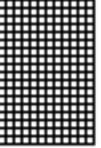
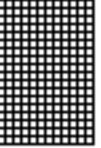
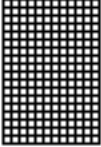
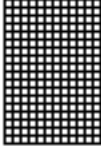
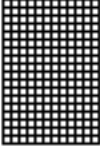
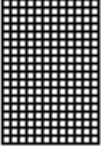
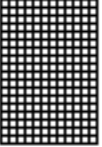
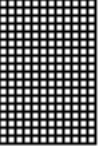
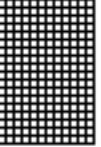
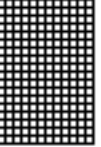
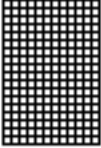
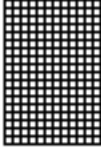
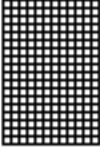
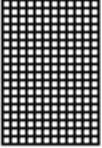
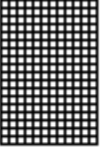
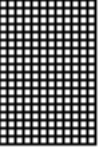
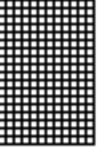
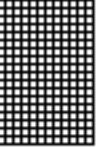
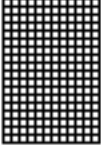
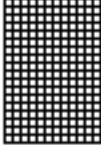
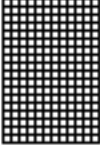
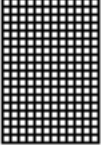
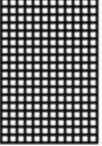
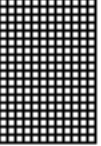
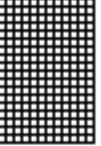
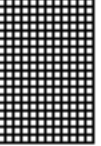
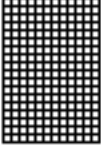
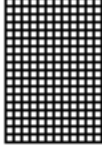
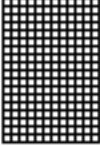
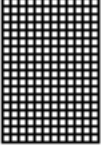
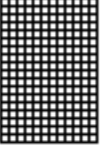
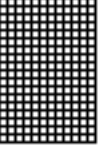
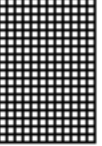
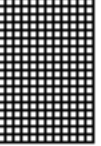

Fig. 15 M35046-001SP/FP character pattern (4)

SCREEN CHARACTER and PATTERN DISPLAY CONTROLLERS

00 <sub>16</sub>	01 <sub>16</sub>	02 <sub>16</sub>	03 <sub>16</sub>	04 <sub>16</sub>	05 <sub>16</sub>	06 <sub>16</sub>	07 <sub>16</sub>
							
08 <sub>16</sub>	09 <sub>16</sub>	0A <sub>16</sub>	0B <sub>16</sub>	0C <sub>16</sub>	0D <sub>16</sub>	0E <sub>16</sub>	0F <sub>16</sub>
							
10 <sub>16</sub>	11 <sub>16</sub>	12 <sub>16</sub>	13 <sub>16</sub>	14 <sub>16</sub>	15 <sub>16</sub>	16 <sub>16</sub>	17 <sub>16</sub>
							
18 <sub>16</sub>	19 <sub>16</sub>	1A <sub>16</sub>	1B <sub>16</sub>	1C <sub>16</sub>	1D <sub>16</sub>	1E <sub>16</sub>	1F <sub>16</sub>
							
20 <sub>16</sub>	21 <sub>16</sub>	22 <sub>16</sub>	23 <sub>16</sub>	24 <sub>16</sub>	25 <sub>16</sub>	26 <sub>16</sub>	27 <sub>16</sub>
							
28 <sub>16</sub>	29 <sub>16</sub>	2A <sub>16</sub>	2B <sub>16</sub>	2C <sub>16</sub>	2D <sub>16</sub>	2E <sub>16</sub>	2F <sub>16</sub>
							
30 <sub>16</sub>	31 <sub>16</sub>	32 <sub>16</sub>	33 <sub>16</sub>	34 <sub>16</sub>	35 <sub>16</sub>	36 <sub>16</sub>	37 <sub>16</sub>
							
38 <sub>16</sub>	39 <sub>16</sub>	3A <sub>16</sub>	3B <sub>16</sub>	3C <sub>16</sub>	3D <sub>16</sub>	3E <sub>16</sub>	3F <sub>16</sub>
							

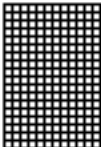
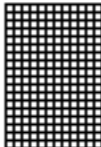
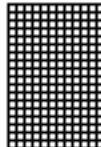
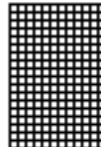
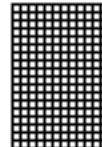
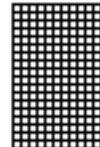
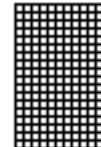
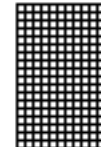
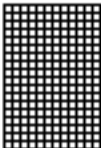
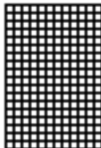
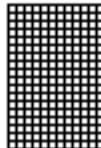
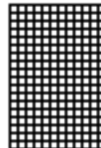
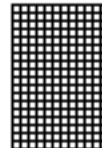
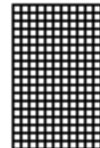
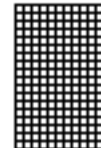
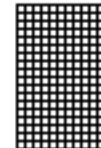
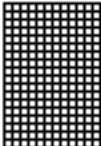
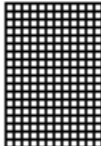
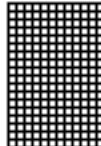
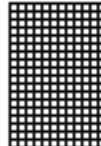
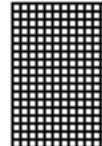
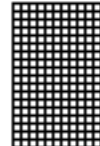
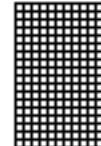
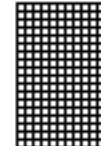
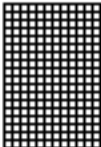
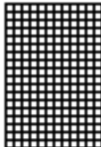
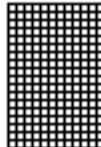
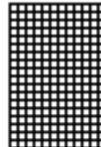
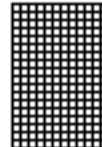
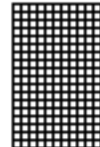
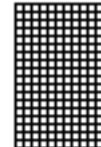
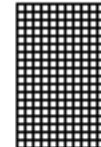
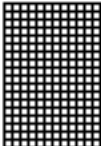
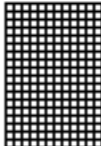
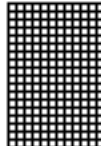
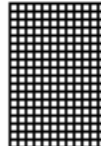
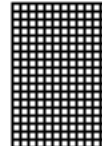
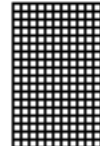
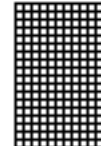
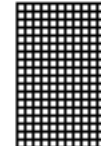
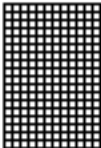
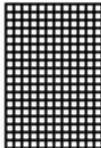
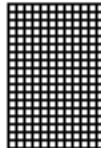
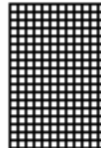
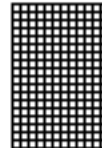
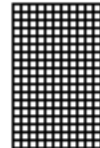
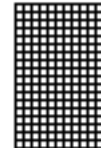
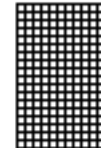
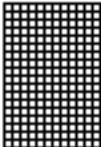
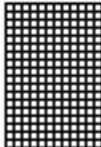
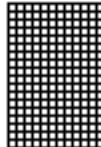
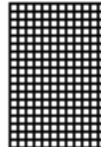
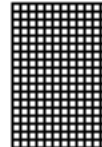
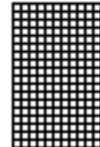
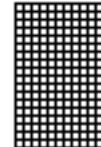
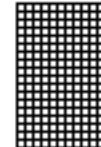
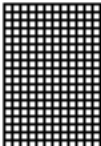
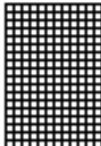
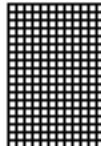
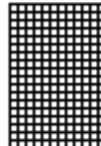
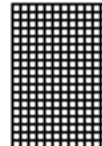
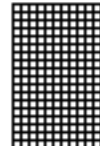
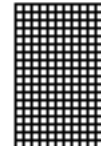
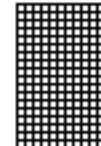

SCREEN CHARACTER and PATTERN DISPLAY CONTROLLERS

40 <sub>16</sub> 	41 <sub>16</sub> 	42 <sub>16</sub> 	43 <sub>16</sub> 	44 <sub>16</sub> 	45 <sub>16</sub> 	46 <sub>16</sub> 	47 <sub>16</sub> 
48 <sub>16</sub> 	49 <sub>16</sub> 	4A <sub>16</sub> 	4B <sub>16</sub> 	4C <sub>16</sub> 	4D <sub>16</sub> 	4E <sub>16</sub> 	4F <sub>16</sub> 
50 <sub>16</sub> 	51 <sub>16</sub> 	52 <sub>16</sub> 	53 <sub>16</sub> 	54 <sub>16</sub> 	55 <sub>16</sub> 	56 <sub>16</sub> 	57 <sub>16</sub> 
58 <sub>16</sub> 	59 <sub>16</sub> 	5A <sub>16</sub> 	5B <sub>16</sub> 	5C <sub>16</sub> 	5D <sub>16</sub> 	5E <sub>16</sub> 	5F <sub>16</sub> 
60 <sub>16</sub> 	61 <sub>16</sub> 	62 <sub>16</sub> 	63 <sub>16</sub> 	64 <sub>16</sub> 	65 <sub>16</sub> 	66 <sub>16</sub> 	67 <sub>16</sub> 
68 <sub>16</sub> 	69 <sub>16</sub> 	6A <sub>16</sub> 	6B <sub>16</sub> 	6C <sub>16</sub> 	6D <sub>16</sub> 	6E <sub>16</sub> 	6F <sub>16</sub> 
70 <sub>16</sub> 	71 <sub>16</sub> 	72 <sub>16</sub> 	73 <sub>16</sub> 	74 <sub>16</sub> 	75 <sub>16</sub> 	76 <sub>16</sub> 	77 <sub>16</sub> 
78 <sub>16</sub> 	79 <sub>16</sub> 	7A <sub>16</sub> 	7B <sub>16</sub> 	7C <sub>16</sub> 	7D <sub>16</sub> 	7E <sub>16</sub> 	7F <sub>16</sub> blank 

SCREEN CHARACTER and PATTERN DISPLAY CONTROLLERS

---

8016	8116	8216	8316	8416	8516	8616	8716
8816	8916	8A16	8B16	8C16	8D16	8E16	8F16
9016	9116	9216	9316	9416	9516	9616	9716
9816	9916	9A16	9B16	9C16	9D16	9E16	9F16
A016	A116	A216	A316	A416	A516	A616	A716
A816	A916	AA16	AB16	AC16	AD16	AE16	AF16
B016	B116	B216	B316	B416	B516	B616	B716
B816	B916	BA16	BB16	BC16	BD16	BE16	BF16

---

SCREEN CHARACTER and PATTERN DISPLAY CONTROLLERS

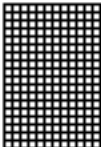
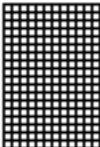
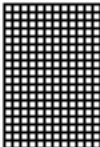
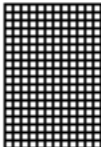
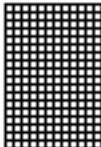
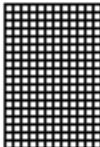
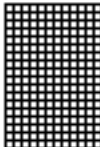
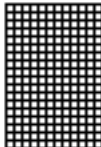
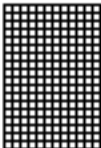
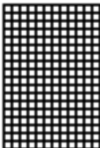
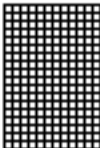
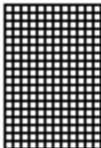
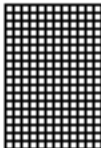
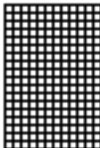
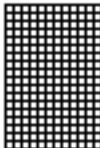
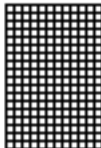
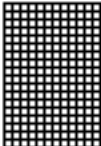
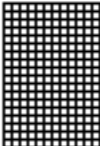
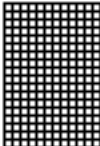
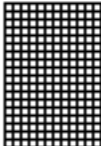
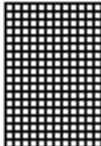
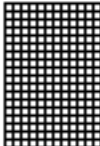
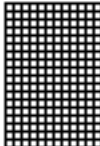
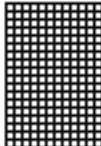
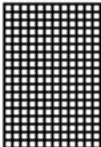
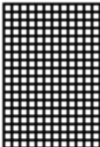
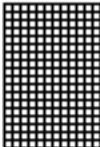
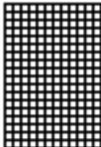
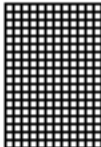
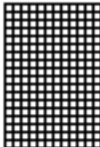
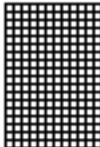
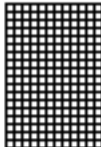
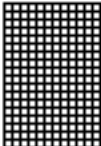
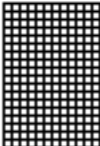
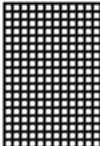
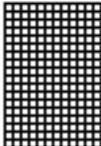
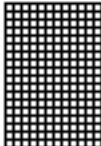
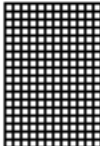
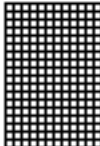
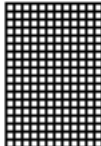
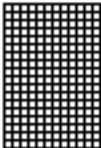
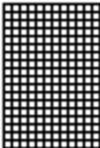
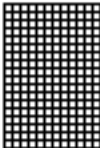
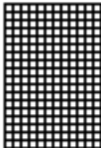
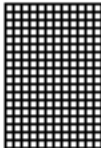
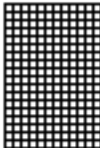
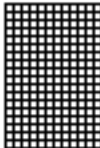
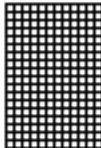
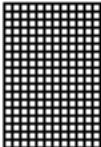
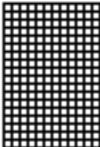
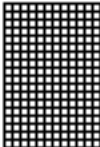
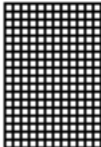
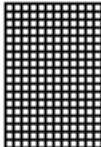
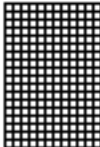
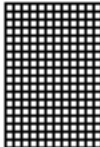
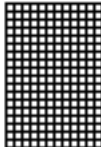
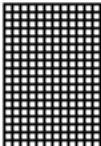
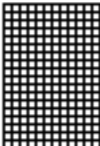
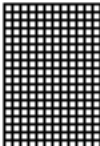
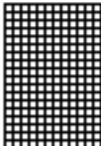
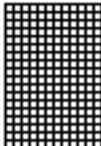
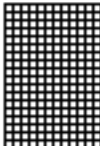
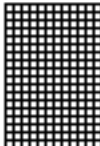
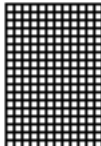
C016	C116	C216	C316	C416	C516	C616	C716
							
C816	C916	CA16	CB16	CC16	CD16	CE16	CF16
							
D016	D116	D216	D316	D416	D516	D616	D716
							
D816	D916	DA16	DB16	DC16	DD16	DE16	DF16
							
E016	E116	E216	E316	E416	E516	E616	E716
							
E816	E916	EA16	EB16	EC16	ED16	EE16	EF16
							
F016	F116	F216	F316	F416	F516	F616	F716
							
F816	F916	FA16	FB16	FC16	FD16	FE16	FF16 blank
							

MITSUBISHI MICROCOMPUTERS

**M35046-XXXSP/FP**

SCREEN CHARACTER and PATTERN DISPLAY CONTROLLERS

---

---

MITSUBISHI MICROCOMPUTERS

**M35046-XXXSP/FP**

SCREEN CHARACTER and PATTERN DISPLAY CONTROLLERS

---

---

PACKAGE OUTLINE

20P4B

Plastic 20pin 300mil SDIP

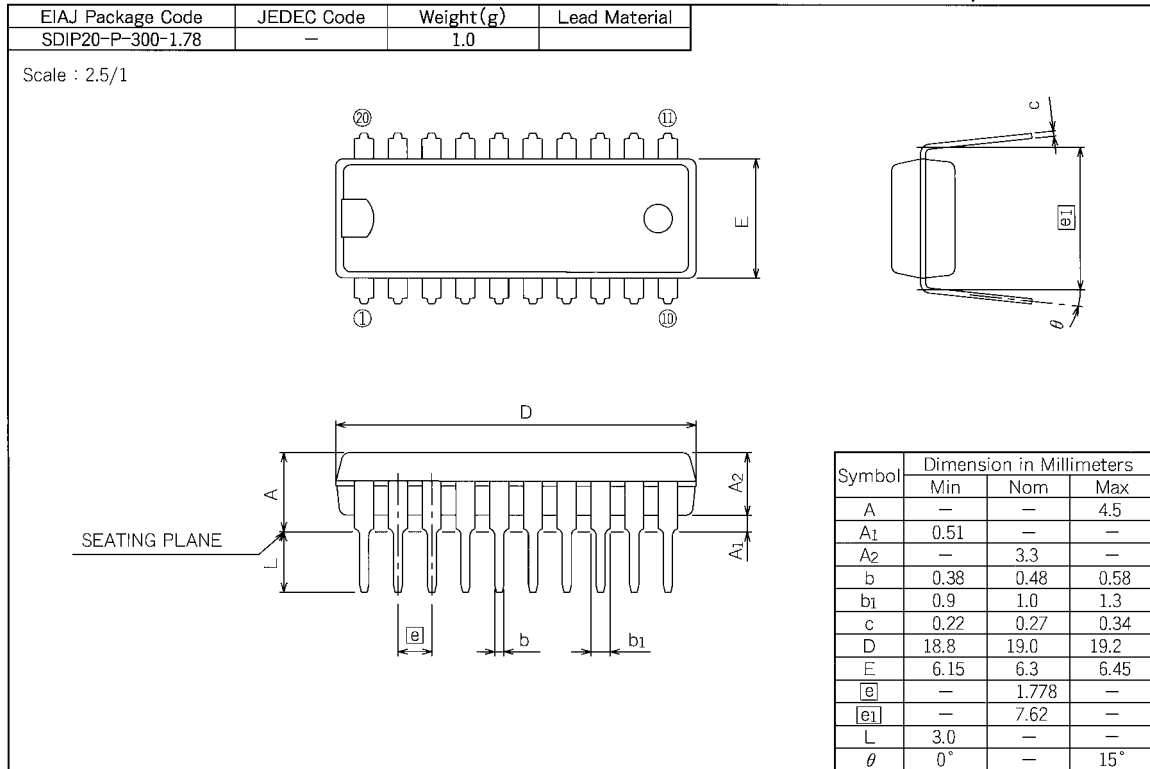

20P2Q-A

Plastic 20pin 300mil SSOP

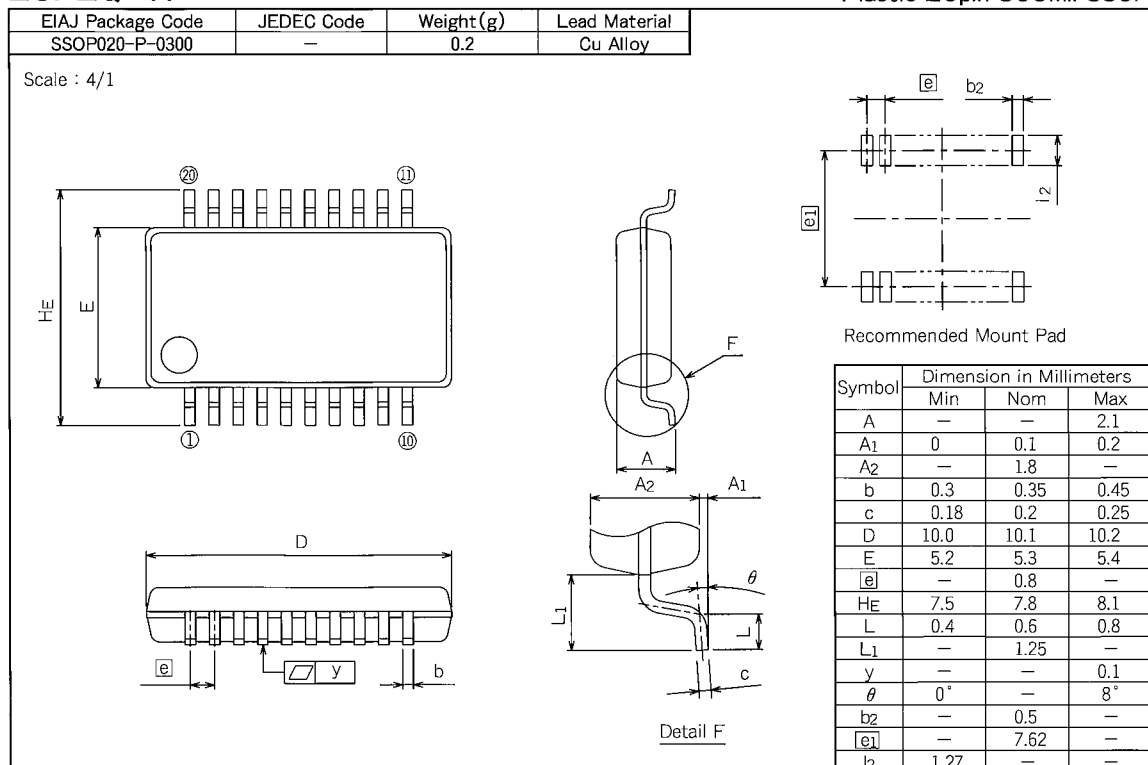

MITSUBISHI MICROCOMPUTERS

**M35046-XXXSP/FP**

SCREEN CHARACTER and PATTERN DISPLAY CONTROLLERS

---

MEMO

---

MITSUBISHI MICROCOMPUTERS

**M35046-XXXSP/FP**

SCREEN CHARACTER and PATTERN DISPLAY CONTROLLERS

---

---