

6249828 0016662 671 MIT4

查询M37450S1FP供应商

捷多邦 专业PCB打样工厂, 24小时加急出货

M37450S1SP/FP, M37450S2SP/FP

M37450S4SP/FP

8-BIT CMOS MICROCOMPUTER

DESCRIPTION

The M37450S1SP/FP is a single-chip microcomputer designed with CMOS silicon gate technology. It is housed in a 64-pin shrink plastic molded DIP or an 80-pin plastic molded QFP. In addition to its simple instruction sets, the ROM, RAM and I/O addresses are placed on the same memory map to enable easy programming. It is suited for office automation equipment and control devices. The low power consumption made possible by the use of a CMOS process makes it especially suitable for battery powered devices requiring low power consumption. It also has a unique feature that enables it to be used as a slave microcomputer.

M37450S1SP/FP, M37450S2SP/FP and M37450S4SP/FP have basically the same functions as M37450M2-XXXSP/FP except the RAM size and the fact that these three need external ROM area. The differences among M37450S1SP/FP, M37450S2SP/FP and M37450S4SP/FP are as shown below.

Type	RAM size
M37450S1SP/FP	128 bytes
M37450S2SP/FP	256 bytes
M37450S4SP/FP	448 bytes

Also M37450S1SP has the same function as M37450M2-XXXSP/FP in microprocessor mode and M37450S2SP/FP has the same function as M37450M4-XXXSP/FP in microprocessor mode.

FEATURES

- Number of basic instructions..... 71
69 MELPS 740 basic instructions + 2 multiply/divide instructions
- Memory size ROM None
RAM 128 bytes (M37450S1SP/FP)
256 bytes (M37450S2SP/FP)
448 bytes (M37450S4SP/FP)
- Instruction execution time
(minimum instructions at 10 MHz frequency) 0.8μs
- Single power supply 5V ± 10%
- Power dissipation normal operation mode
(at 10MHz frequency) 30mW
- Subroutine nesting 64 levels max. (M37450S1SP/FP)
- Interrupt..... 15 events
- Master CPU bus interface 1 byte
- 16-bit timer 3
- 8-bit timer (Serial I/O use) 1
- Serial I/O (UART or clock synchronous) 1
- A-D converter (8bit resolution) 3 channels (DIP)
8 channels (QFP)
- D-A converter (8-bit resolution) 2 channels
- PWM output (8-bit or 16-bit) 1
- Programmable I/O
(Ports P0, P1, P2, P3, P5, P6) 48
Input (Port P4) 3 (DIP), 8 (QFP)
Output (Port D-A₁, D-A₂) 2

PIN CONFIGURATION (TOP VIEW)

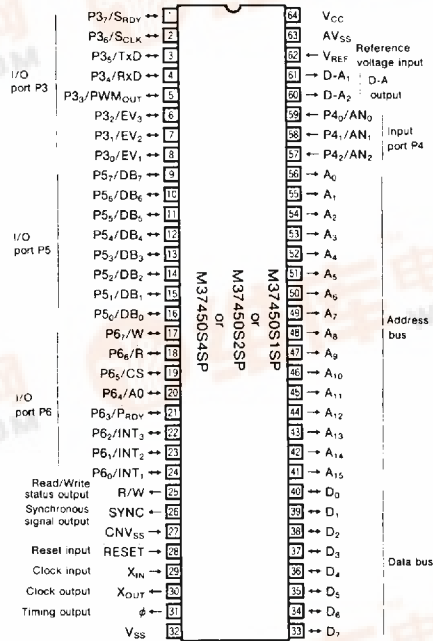

Outline 64P4B

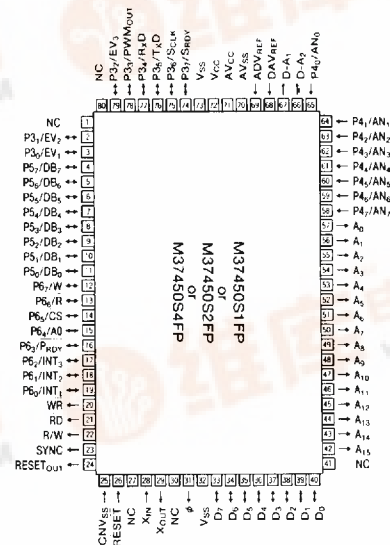

Outline 80P6 NC: No connection

APPLICATION

Slave controller for PPCs, facsimiles and page printers
HDD, optical disk, inverter and industrial motor controllers
Industrial robots and machines



M37450S1SP/FP, M37450S2SP/FP, M37450S4SP/FP

8-BIT CMOS MICROCOMPUTER

MITSUBISHI (MICMPTR/MIPRC) 61E D

M37450S1FP BLOCK DIAGRAM

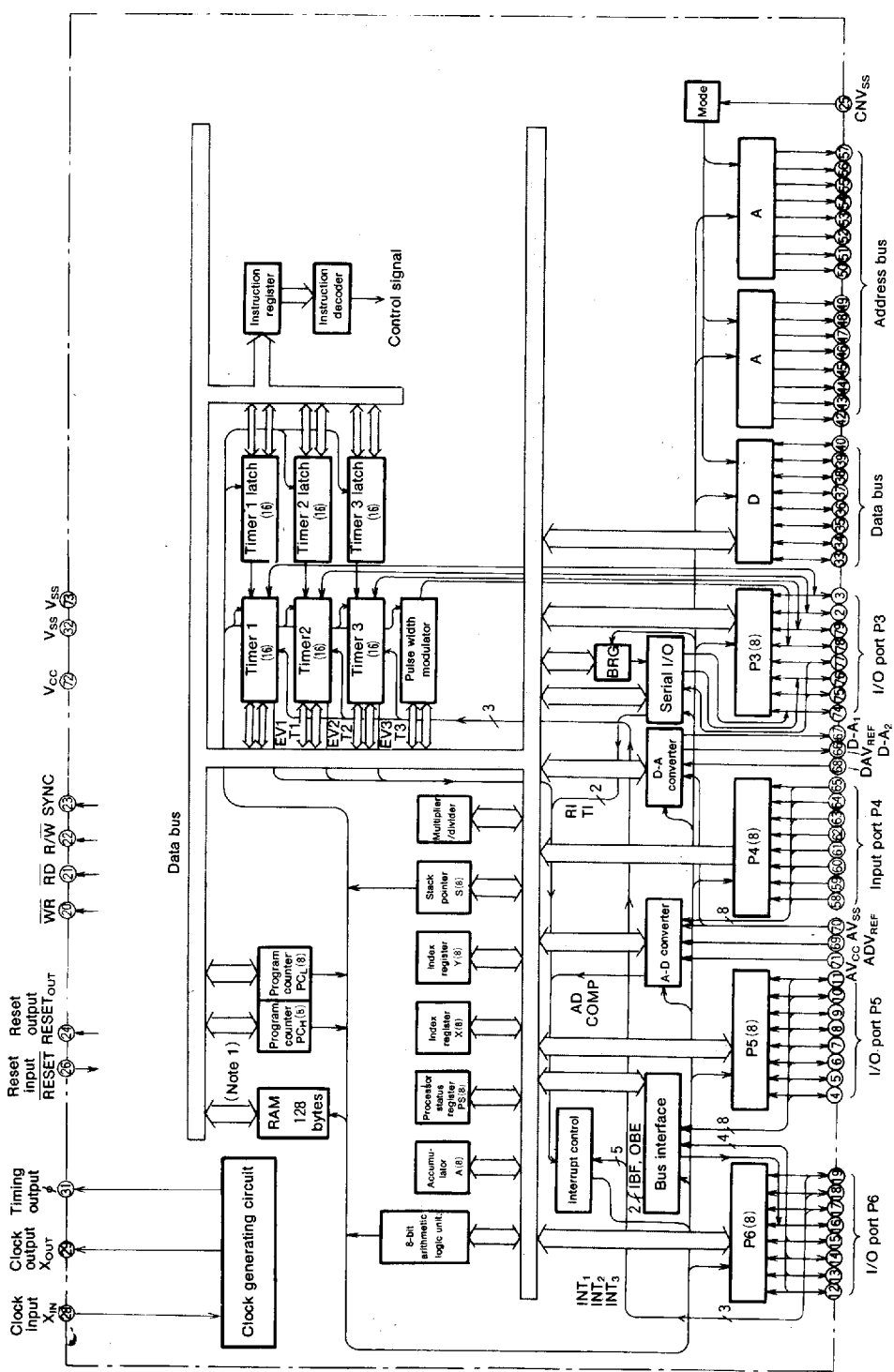

Note 1 : 256 bytes for M37450S2FP and 448 bytes for M37450S4FP.

6249828 0016665 380 ■ MIT4

MITSUBISHI MICROCOMPUTERS

M37450S1SP/FP, M37450S2SP/FP

M37450S4SP/FP

MITSUBISHI(MICMPTR/MIPRC) 61E D

8-BIT CMOS MICROCOMPUTER

FUNCTIONS OF M37450S1SP/FP, M37450S2SP/FP, M37450S4SP/FP

Parameter		Function
Number of basic instructions		71(69 MELPS 740 basic instructions+2)
Instruction execution time		0.8 μ s(minimum instructions, at 10MHz of frequency)
Clock frequency		10MHz(max.)
RAM size	M37450S1SP/FP	128 bytes
	M37450S2SP/FP	256 bytes
	M37450S4SP/FP	448 bytes
Input/Output port	P3, P5, P6	I/O
	P4	Input
	D-A	Output
Serial I/O		UART or clock synchronous
Timers		16-bit timerX3, 8-bit timer(serial I/O baud rate generator)X1
A-D converter		8-bitX3 channels(8 channels for 80-pin model)
D-A converter		8-bitX2 channels
Pulse width modulator		8-bit or 16-bitX1
Data bus buffer		1-byte input and output each
Subroutine nesting		64-levels(max. for M37450S1SP/FP) 96-levels(max. for M37450S2SP/FP, M37450S4SP/FP)
Interrupt		6 external interrupts, 8 internal interrupts one software interrupt
Clock generating circuit		Built-in(ceramic or quartz crystal oscillator)
Supply voltage		5V \pm 10%
Power dissipation		30mW(at 10MHz frequency)
Input/Output characters	Input/Output voltage	5V
	Output current	\pm 5mA(max.)
Operating temperature range		-10~70°C
Device structure		CMOS silicon gate
Package	M37450S1SP, M37450S2SP, M37450S4SP	64-pin shrink plastic molded DIP
	M37450S1FP, M37450S2FP, M37450S4FP	80-pin plastic molded QFP

**M37450S1SP/FP, M37450S2SP/FP
M37450S4SP/FP**

MITSUBISHI(MICMPTR/MIPRC) BLE D

8-BIT CMOS MICROCOMPUTER

PIN DESCRIPTION

Pin	Name	Input/ Output	Functions
V _{CC} , V _{SS}	Supply voltage		Power supply inputs 5V±10% to V _{CC} , and 0V to V _{SS} .
CNV _{SS}	CNV _{SS}	Input	This is connected to V _{CC} .
RESET	Reset input	Input	To enter the reset state, the reset input pin must be kept at a "L" for more than 8 clock cycles (under normal V _{CC} conditions). If more time is needed for the crystal oscillator to stabilize, this "L" condition should be maintained for the required time.
X _{IN}	Clock input	Input	This chip has an internal clock generating circuit. To control generating frequency, an external ceramic or a quartz crystal oscillator is connected between the X _{IN} and X _{OUT} pins. If an external clock is used, the clock source should be connected to the X _{IN} pin and the X _{OUT} pin should be left open.
X _{OUT}	Clock output	Output	
φ	Timing output	Output	Outputs signal consisting of oscillating frequency divided by four.
SYNC	Synchronous signal output	Output	This signal is output "H" during operation code fetch and is used to control single stepping of programs.
R/W	Read/Write status output	Output	This signal determines the direction of the data bus. It is "H" during read and "L" during write
A ₀ ~A ₁₅	Address bus	Output	This is 16-bit address bus.
D ₀ ~D ₇	Data bus	I/O	This is 8-bit data bus.
P ₃₀ ~P ₃₇	Input/Output port P3	I/O	Port P3 is an 8-bit I/O port with directional registers allowing each I/O bit to be individually programmed as input or output. The output structure is CMOS output. Serial I/O, PWM output, or even I/O function can be selected with a program.
P ₄₀ ~P ₄₂ (P ₄₀ ~P ₄₇)	Input port P4	Input	Analog input pin for the A-D converter. The 64-pin model has three pins and the 80-pin model has eight pins. They may also be used as digital input pins.
P ₅₀ ~P ₅₇	Input/Output port P5	I/O	An 8-bit input/output port with the same function as P3. This port functions as an 8-bit data bus for the master CPU when slave mode is selected with a program.
P ₆₀ ~P ₆₇	Input/Output port P6	I/O	An 8-bit input/output port with the same function as P0. Pins P ₆₃ ~P ₆₇ change to a control bus for the master CPU when slave mode is selected with a program. Pins P ₆₀ ~P ₆₂ may be programmed as external interrupt input pins.
D-A ₁ , D-A ₂	D-A output	Output	Analog signal from D-A converter is output.
V _{REF}	Reference voltage input	Input	Reference voltage input pin for A-D and D-A converter. This pin is for 64-pin model only.
ADV _{REF}	A-D reference voltage input	Input	Reference voltage input pin for A-D converter. This pin is for 80-pin model only.
DAV _{REF}	D-A reference voltage input	Input	Reference voltage input pin for D-A converter. This pin is for 80-pin model only.
AV _{SS}	Analog power supply		Ground level input pin for A-D and D-A converter. Same voltage as V _{SS} is applied.
AV _{CC}	Analog power supply		Power supply input pin for A-D converter. This pin is for 80-pin model only. Same voltage as V _{CC} is applied. In the case of the 64-pin model AV _{CC} is connected to V _{CC} internally.
RD	Read signal output	Output	Control signal output as active "L" when valid data is read from data bus. This pin is for 80-pin model only.
WR	Write signal output	Output	Control signal output as active "L" when writing data from data bus to external component. This pin is for 80-pin model only.
RESET _{OUT}	Reset output	Output	Control signal output as active "H" during reset. It is used as a reset output signal for peripheral components. This pin is for 80-pin model only.

**M37450S1SP/FP, M37450S2SP/FP
M37450S4SP/FP**

MITSUBISHI(MICMPTR/MIPRC) 61E D

8-BIT CMOS MICROCOMPUTER

BASIC FUNCTION BLOCKS

The differences between M37450M2-XXXSP/FP and M37450S1SP/FP are noted below. Other functions are the same as M37450M2-XXXSP/FP in microprocessor mode.

MEMORY

A memory map for the M37450S1SP/FP is shown in Figure 1. Addresses FF0₁₆ to FFFF₁₆ are a special address area (special page). By using the special page addressing mode of the JSR instruction, subroutines addressed on this page can be called with only 2 bytes. Addresses FF0₁₆ to FFFF₁₆ are vector addresses used for the reset and interrupts (This area must be located in ROM area). Addresses 0000₁₆~00FF₁₆ are the zero page address area.

By using the zero page addressing mode, this area can also be accessed with 2 bytes. The use of these addressing methods will greatly reduce the object size required. The RAM, I/O port, timer, etc., are assigned to this area. Addresses 0000₁₆ to 007F₁₆ are the RAM address area assigned to the M37450S1SP/FP and consist of 128 bytes. Addresses 0000₁₆ to 00BF₁₆ and 0100₁₆ to 013F₁₆ are the RAM address area assigned to the M37450S2SP/FP and consist of 192 bytes and 64 bytes respectively. Addresses 0000₁₆ to 00BF₁₆ and 0100₁₆ to 01FF₁₆ are the RAM address area assigned to the M37450S4SP/FP and consist of 192 bytes and 256 bytes respectively. In addition to data storage, this RAM is used for the stack during subroutine calls and interrupts.

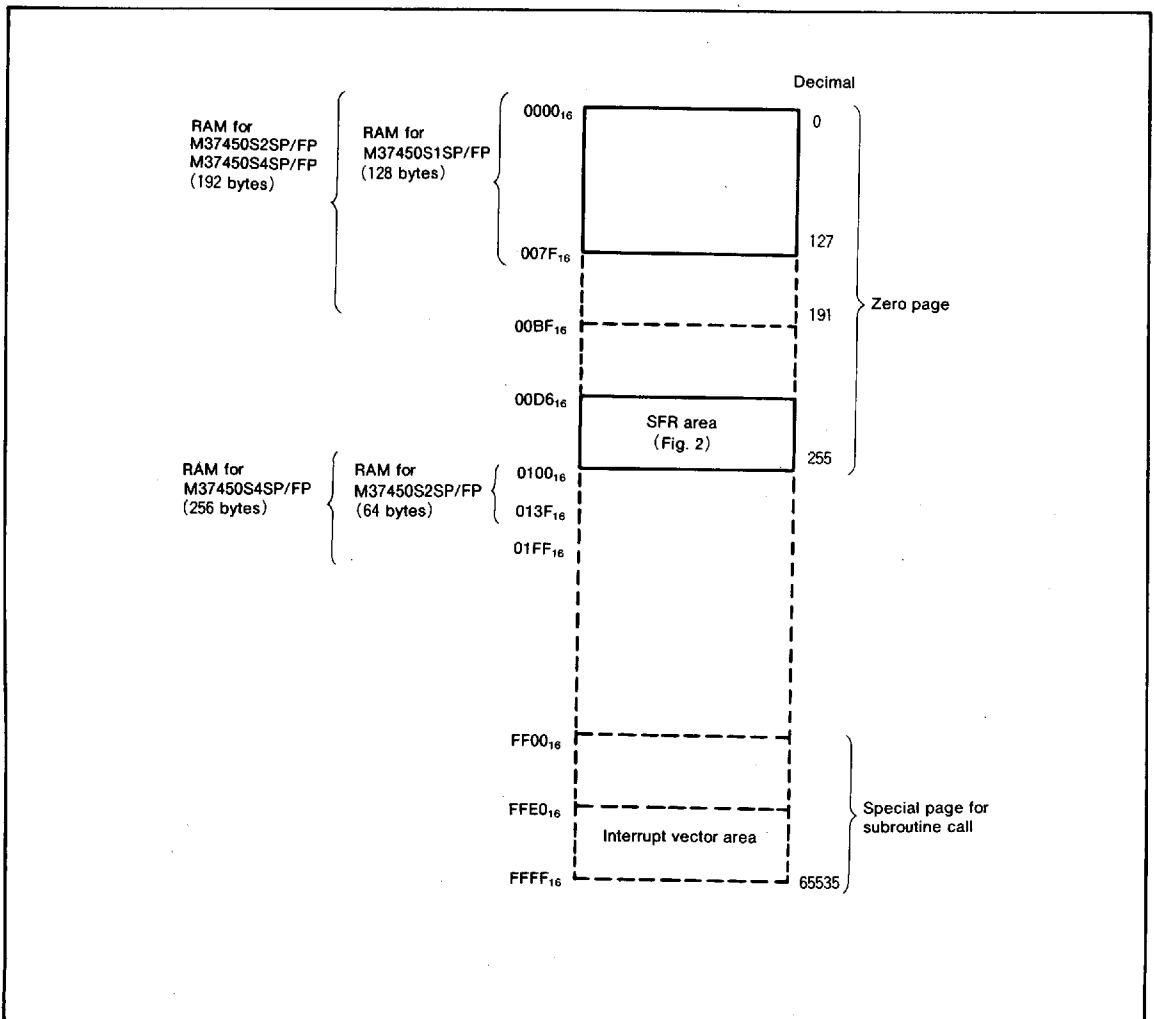

Fig. 1 Memory map

**M37450S1SP/FP, M37450S2SP/FP
M37450S4SP/FP**

MITSUBISHI(MICMPTR/MIPRC) 61E D

8-BIT CMOS MICROCOMPUTER

00D6 ₁₆	P3 register	00EB ₁₆	PWM register (low-order)
00D7 ₁₆	P3 directional register	00EC ₁₆	PWM register (high-order)
00D8 ₁₆	P4 register	00ED ₁₆	Timer 1 control register
00D9 ₁₆	Reserved	00EE ₁₆	Timer 2 control register
00DA ₁₆	P5 register	00EF ₁₆	Timer 3 control register
00DB ₁₆	P5 directional register	00F0 ₁₆	Timer 1 register (low-order)
00DC ₁₆	P6 register	00F1 ₁₆	Timer 1 register (high-order)
00DD ₁₆	P6 directional register	00F2 ₁₆	Timer 1 latch (low-order)
00DE ₁₆	MISRG1	00F3 ₁₆	Timer 1 latch (high-order)
00DF ₁₆	MISRG2	00F4 ₁₆	Timer 2 register (low-order)
00E0 ₁₆	D-A1 register	00F5 ₁₆	Timer 2 register (high-order)
00E1 ₁₆	D-A2 register	00F6 ₁₆	Timer 2 latch (low-order)
00E2 ₁₆	A-D register	00F7 ₁₆	Timer 2 latch (high-order)
00E3 ₁₆	A-D control register	00F8 ₁₆	Timer 3 register (low-order)
00E4 ₁₆	Data bus buffer register	00F9 ₁₆	Timer 3 register (high-order)
00E5 ₁₆	Data bus buffer status register	00FA ₁₆	Timer 3 latch (low-order)
00E6 ₁₆	Receive/transmit buffer register	00FB ₁₆	Timer 3 latch (high-order)
00E7 ₁₆	Serial I/O status register	00FC ₁₆	Interrupt request register 1
00E8 ₁₆	Serial I/O control register	00FD ₁₆	Interrupt request register 2
00E9 ₁₆	UART control register	00FE ₁₆	Interrupt control register 1
00EA ₁₆	Baud rate generator	00FF ₁₆	Interrupt control register 2

Fig. 2 SFR (Special Function Register) memory map

**M37450S1SP/FP, M37450S2SP/FP
M37450S4SP/FP**

MITSUBISHI (MICMPTR/MIPRC) 61E D

8-BIT CMOS MICROCOMPUTER

ABSOLUTE MAXIMUM RATINGS

Symbol	Parameter	Conditions	Ratings	Unit
V _{CC}	Supply voltage		-0.3~7	V
V _I	Input voltage RESET, X _{IN}		-0.3~7	V
V _I	Input voltage D ₀ ~D ₇ , P ₃₀ ~P ₃₇ , P ₄₀ ~P ₄₇ , P ₅₀ ~P ₅₇ , P ₆₀ ~P ₆₇ , ADV _{REF} , DAV _{REF} , V _{REF} , AV _{CC}	With respect to V _{SS} Output transistors are at "OFF" state.	-0.3~V _{CC} +0.3	V
V _I	Input voltage CNV _{SS}		-0.3~13	V
V _O	Output voltage A ₀ ~A ₁₅ , D ₀ ~D ₇ , P ₃₀ ~P ₃₇ , P ₅₀ ~P ₅₇ , P ₆₀ ~P ₆₇ , X _{OUT} , ϕ, RD, WR, R/W, RESET _{OUT} , SYNC		-0.3~V _{CC} +0.3	V
P _d	Power dissipation	T _a = 25°C	1000 (Note 1)	mW
T _{opr}	Operating temperature		-10~70	°C
T _{stg}	Storage temperature		-40~125	°C

Note 1 : 500mW for QFP type.

RECOMMENDED OPERATING CONDITIONS

(V_{CC}=5V±10%, T_a=-10~70°C unless otherwise noted)

Symbol	Parameter	Limits			Unit
		Min.	Nom.	Max.	
V _{CC}	Supply voltage	4.5	5	5.5	V
V _{SS}	Supply voltage		0		V
V _{IH}	"H" Input voltage RESET, X _{IN} , CNV _{SS} (Note 2)	0.8V _{CC}		V _{CC}	V
V _{IH}	"H" Input voltage D ₀ ~D ₇ , P ₃₀ ~P ₃₇ , P ₄₀ ~P ₄₇ , P ₅₀ ~P ₅₇ , P ₆₀ ~P ₆₇ (except Note 2)	2.0		V _{CC}	V
V _{IL}	"L" Input voltage CNV _{SS} (Note 2)	0		0.2V _{CC}	V
V _{IL}	"L" Input voltage D ₀ ~D ₇ , P ₃₀ ~P ₃₇ , P ₄₀ ~P ₄₇ , P ₅₀ ~P ₅₇ , P ₆₀ ~P ₆₇ (except Note 2)	0		0.8	V
V _{IL}	"L" Input voltage RESET	0		0.12V _{CC}	V
V _{IL}	"L" Input voltage X _{IN}	0		0.16V _{CC}	V
I _{OL(peak)}	"L" peak output current A ₀ ~A ₁₅ , D ₀ ~D ₇ , P ₃₀ ~P ₃₇ , P ₅₀ ~P ₅₇ , P ₆₀ ~P ₆₇			10	mA
I _{OL(avg)}	"L" average output current A ₀ ~A ₁₅ , D ₀ ~D ₇ , P ₃₀ ~P ₃₇ , P ₅₀ ~P ₅₇ , P ₆₀ ~P ₆₇ (Note 3)			5	mA
I _{OH(peak)}	"H" peak output current A ₀ ~A ₁₅ , D ₀ ~D ₇ , P ₃₀ ~P ₃₇ , P ₅₀ ~P ₅₇ , P ₆₀ ~P ₆₇			-10	mA
I _{OH(avg)}	"H" average output current A ₀ ~A ₁₅ , D ₀ ~D ₇ , P ₃₀ ~P ₃₇ , P ₅₀ ~P ₅₇ , P ₆₀ ~P ₆₇ (Note 3)			-5	mA
f(X _{IN})	Clock oscillating frequency	1		10	MHz

- Note 2 : Ports operate as INT₁~INT₃(P₆₀~P₆₇), EV₁~EV₃(P₃₀~P₃₇), RxD(P₃₄) and S_{CLK}(P₃₆)
- 3 : The average output current I_{OH(avg)} and I_{OL(avg)} are the average value during a 100ms.
- 4 : The total of "L" output current I_{OL(peak)} of port P3, P5, P6, R/W SYNC, RESET_{OUT}, RD, WR and ϕ is less than 40mA.
The total of "H" output current I_{OH(peak)} of port P3, P5, P6, R/W SYNC, RESET_{OUT}, RD, WR and ϕ is less than 40mA.

**M37450S1SP/FP, M37450S2SP/FP
M37450S4SP/FP**

MITSUBISHI(MICMPTR/MIPRC) 61E D

8-BIT CMOS MICROCOMPUTER

ELECTRICAL CHARACTERISTICS ($V_{CC} = 5V \pm 10\%$, $V_{SS} = 0V$, $T_a = -10 \sim 70^\circ C$, $f(X_{IN}) = 10MHz$, unless otherwise noted)

Symbol	Parameter	Test conditions	Limits			Unit
			Min.	Typ.	Max.	
V_{OH}	"H" output voltage \overline{RD} , \overline{WR} , $\overline{R/W}$, SYNC, RESET _{OUT} , ϕ	$I_{OH} = -2mA$	$V_{CC} - 1$			V
V_{OH}	"H" output voltage $A_0 \sim A_{15}$, $D_0 \sim D_7$, $P_3_0 \sim P_3_7$, $P_5_0 \sim P_5_7$, $P_6_0 \sim P_6_7$	$I_{OH} = -5mA$	$V_{CC} - 1$			V
V_{OL}	"L" output voltage $A_0 \sim A_{15}$, $D_0 \sim D_7$, $P_3_0 \sim P_3_7$, $P_5_0 \sim P_5_7$, $P_6_0 \sim P_6_7$, \overline{RD} , \overline{WR} , $\overline{R/W}$, SYNC, RESET _{OUT} , ϕ	$I_{OL} = 2mA$			0.45	V
V_{OL}	"L" output voltage $A_0 \sim A_{15}$, $D_0 \sim D_7$, $P_3_0 \sim P_3_7$, $P_5_0 \sim P_5_7$, $P_6_0 \sim P_6_7$	$I_{OL} = 5mA$			1	V
$V_{T+} - V_{T-}$	Hysteresis INT ₁ ~ INT ₃ ($P_6_0 \sim P_6_2$), EV ₁ ~ EV ₃ ($P_3_0 \sim P_3_2$), $R_XD(P_3_4)$, $S_{CLK}(P_3_6)$	Function input level	0.3		1	V
$V_{T+} - V_{T-}$	Hysteresis RESET				0.7	V
$V_{T+} - V_{T-}$	Hysteresis X_{IN}		0.1		0.5	V
I_{IL}	"L" input current $D_0 \sim D_7$, $P_3_0 \sim P_3_7$, $P_4_0 \sim P_4_7$, $P_5_0 \sim P_5_7$, $P_6_0 \sim P_6_7$, RESET, X_{IN}	$V_I = V_{SS}$	-5		5	μA
I_{IH}	"H" input current $D_0 \sim D_7$, $P_3_0 \sim P_3_7$, $P_4_0 \sim P_4_7$, $P_5_0 \sim P_5_7$, $P_6_0 \sim P_6_7$, RESET, X_{IN}	$V_I = V_{CC}$	-5		5	μA
V_{RAM}	RAM retention voltage	At stop mode	2			V
I_{CC}	Supply current	At system operation $f(X_{IN}) = 10MHz$		6	10	mA
		At stop mode (Note 5)		1	10	μA

Note 5 : The terminals \overline{RD} , \overline{WR} , $\overline{R/W}$, SYNC, RESET_{OUT}, ϕ , D-A₁ and D-A₂ are all open. The other ports, which are in the input mode, are connected to V_{SS} . A-D converter is in the A-D completion state. The current through ADV_{REF} and DAV_{REF} is not included (Fig.6).

A-D CONVERTER CHARACTERISTICS

($V_{CC} = AV_{CC} = 5V$, $V_{SS} = AV_{SS} = 0V$, $T_a = 25^\circ C$, $f(X_{IN}) = 10MHz$, unless otherwise noted)

Symbol	Parameter	Test conditions	Limits			Unit
			Min.	Typ.	Max.	
—	Resolution				8	Bits
—	Absolute accuracy	$V_{CC} = AV_{CC} = ADV_{REF} = 5.12V$		± 1.5	± 3	LSB
t_{CONV}	Conversion time				49	$t_C(\phi)$
V_{IA}	Analog input voltage		AV_{SS}		AV_{CC}	V
V_{ADVREF}	Reference input voltage		2		V_{CC}	V
R_{LADDER}	Ladder resistance value	$ADV_{REF} = 5V$	2	7.5	10	k Ω
$I_{IADVREF}$	Reference input current	$ADV_{REF} = 5V$	0.5	0.7	2.5	mA
V_{AVCC}	Analog power supply input voltage			V_{CC}		V
V_{AVSS}	Analog power supply input voltage			0		V

D-A CONVERTER CHARACTERISTICS ($V_{CC} = 5V$, $V_{SS} = AV_{SS} = 0V$, $T_a = 25^\circ C$, unless otherwise noted)

Symbol	Parameter	Test condition	Limits			Unit
			Min.	Typ.	Max.	
—	Resolution				8	Bits
—	Absolute accuracy	$V_{CC} = DAV_{REF} = 5.12V$			1.0	%
t_{SU}	Setup time				3	μs
R_O	Output resistance		1	2	4	k Ω
V_{AVSS}	Analog power supply input voltage			0		V
V_{DAVREF}	Reference input voltage		4		V_{CC}	V
I_{DAVREF}	Reference power input current		0	2.5	5	mA

**M37450S1SP/FP, M37450S2SP/FP
M37450S4SP/FP**

MITSUBISHI (MICMPTR/MIPRC) 6JE D

8-BIT CMOS MICROCOMPUTER

TIMING REQUIREMENTS

Port/Single-chip mode ($V_{CC}=5V\pm 10\%$, $V_{SS}=0V$, $T_a=-10\sim 70^\circ C$, unless otherwise noted)

Symbol	Parameter	Test condition	Limits			Unit
			Min.	Typ.	Max.	
$t_{SU}(P3D-\phi)$	Port P3 input setup time	Fig. 3	200			ns
$t_{SU}(P4D-\phi)$	Port P4 input setup time		200			ns
$t_{SU}(P5D-\phi)$	Port P5 input setup time		200			ns
$t_{SU}(P6D-\phi)$	Port P6 input setup time		200			ns
$t_h(\phi-P3D)$	Port P3 input hold time		40			ns
$t_h(\phi-P4D)$	Port P4 input hold time		40			ns
$t_h(\phi-P5D)$	Port P5 input hold time		40			ns
$t_h(\phi-P6D)$	Port P6 input hold time		40			ns
$t_c(X_{IN})$	External clock input cycle time		100		1000	ns
$t_w(X_{INL})$	External clock input "L" pulse width		30			ns
$t_w(X_{INH})$	External clock input "H" pulse width		30			ns
$t_r(X_{IN})$	External clock rising edge time				20	ns
$t_f(X_{IN})$	External clock falling edge time				20	ns

Master CPU bus interface timing (\overline{R} and \overline{W} separation type mode)

($V_{CC}=5V\pm 10\%$, $V_{SS}=0V$, $T_a=-10\sim 70^\circ C$, unless otherwise noted)

Symbol	Parameter	Test condition	Limits			Unit
			Min.	Typ.	Max.	
$t_{SU}(CS-R)$	\overline{CS} setup time	Fig. 3	0			ns
$t_{SU}(CS-W)$	\overline{CS} setup time		0			ns
$t_h(R-CS)$	\overline{CS} hold time		0			ns
$t_h(W-CS)$	\overline{CS} hold time		0			ns
$t_{SU}(A-R)$	A_0 setup time		40			ns
$t_{SU}(A-W)$	A_0 setup time		40			ns
$t_h(R-A)$	A_0 hold time		10			ns
$t_h(W-A)$	A_0 hold time		10			ns
$t_w(R)$	Read pulse width		160			ns
$t_w(W)$	Write pulse width		160			ns
$t_{SU}(D-W)$	Date input setup time before write		100			ns
$t_h(W-D)$	Date input hold time after write		10			ns

Master CPU bus interface timing (R/\overline{W} type mode)

($V_{CC}=5V\pm 10\%$, $V_{SS}=0V$, $T_a=-10\sim 70^\circ C$, unless otherwise noted)

Symbol	Parameter	Test condition	Limits			Unit
			Min.	Typ.	Max.	
$t_{SU}(CS-E)$	\overline{CS} setup time	Fig. 4	0			ns
$t_h(E-CS)$	\overline{CS} hold time		0			ns
$t_{SU}(A-E)$	A_0 setup time		40			ns
$t_h(E-A)$	A_0 hold time		10			ns
$t_{SU}(RW-E)$	R/W setup time		40			ns
$t_h(E-RW)$	R/W hold time		10			ns
$t_w(EL)$	Enable clock "L" pulse width		160			ns
$t_w(EH)$	Enable clock "H" pulse width		160			ns
$t_r(E)$	Enable clock rising edge time				25	ns
$t_f(E)$	Enable clock falling edge time				25	ns
$t_{SU}(D-E)$	Data input setup time before write		100			ns
$t_h(E-D)$	Data input hold time after write		10			ns

6249828 0016672 510 ■ MIT4

MITSUBISHI MICROCOMPUTERS

**M37450S1SP/FP, M37450S2SP/FP
M37450S4SP/FP**

MITSUBISHI(MICMPTR/MIPRC) 61E D

8-BIT CMOS MICROCOMPUTER

Local bus/Memory expansion mode, Microprocessor mode

($V_{CC}=5V \pm 10\%$, $V_{SS}=0V$, $T_a=-10 \sim 70^\circ C$, unless otherwise noted)

Symbol	Parameter	Test condition	Limits			Unit
			Min.	Typ.	Max.	
$t_{SU(D-\#)}$	Data input setup time	Fig. 5	100			ns
$t_{H(\#-D)}$	Data input hold time		0			ns
$t_{SU(D-RD)}$	Data input setup time		100			ns
$t_{H(RD-D)}$	Data input hold time		0			ns

**M37450S1SP/FP, M37450S2SP/FP
M37450S4SP/FP**

MITSUBISHI(MICMPTR/MIPRC) 61E D

8-BIT CMOS MICROCOMPUTER

SWITCHING CHARACTERISTICS

Port/Single-chip mode ($V_{CC}=5V\pm 10\%$, $V_{SS}=0V$, $T_a=-10\sim 70^\circ C$, unless otherwise noted)

Symbol	Parameter	Test condition	Limits			Unit
			Min.	Typ.	Max.	
$t_d(\phi-P3Q)$	Port P3 data output delay time	Fig. 3			200	ns
$t_d(\phi-P5Q)$	Port P5 data output delay time				200	ns
$t_d(\phi-P6Q)$	Port P6 data output delay time				200	ns
$t_c(\phi)$	Cycle time		400		4000	ns
$t_w(\phi H)$	ϕ clock pulse width ("H" level)		190			ns
$t_w(\phi L)$	ϕ clock pulse width ("L" level)		170			ns
$t_r(\phi)$	ϕ clock rising edge time				20	ns
$t_f(\phi)$	ϕ clock falling edge time				20	ns

Master CPU bus interface (\overline{R} and \overline{W} separation type mode)

($V_{CC}=5V\pm 10\%$, $V_{SS}=0V$, $T_a=-10\sim 70^\circ C$, unless otherwise noted)

Symbol	Parameter	Test condition	Limits			Unit
			Min.	Typ.	Max.	
$t_a(R-D)$	Data output enable time after read	Fig. 4			120	ns
$t_v(R-D)$	Data output disable time after read		10		85	ns
$t_{PLH}(R-PR)$	P_{RDY} output transmission time after read				150	ns
$t_{PLH}(W-PR)$	P_{RDY} output transmission time after write				150	ns

Master CPU bus interface (R/\overline{W} type mode) ($V_{CC}=5V\pm 10\%$, $V_{SS}=0V$, $T_a=-10\sim 70^\circ C$, unless otherwise noted)

Symbol	Parameter	Test condition	Limits			Unit
			Min.	Typ.	Max.	
$t_a(E-D)$	Data output enable time after read	Fig. 4			120	ns
$t_v(E-D)$	Data output disable time after read		10		85	ns
$t_{PLH}(E-PR)$	P_{RDY} output transmission time after E clock				150	ns

Local bus/Memory expansion mode, microprocessor mode

($V_{CC}=5V\pm 10\%$, $V_{SS}=0V$, $T_a=-10\sim 70^\circ C$, unless otherwise noted)

Symbol	Parameter	Test condition	Limits			Unit
			Min.	Typ.	Max.	
$t_d(\phi-A)$	address delay time after ϕ	Fig. 5			120	ns
$t_v(\phi-A)$	address effective time after ϕ		10			ns
$t_v(RD-A)$	address effective time after RD		10			ns
$t_v(WR-A)$	address effective time after WR		10			ns
$t_d(\phi-D)$	data output delay time after ϕ				140	ns
$t_d(WR-D)$	data output delay time after WR				140	ns
$t_v(\phi-D)$	data output effective time after ϕ		20			ns
$t_v(WR-D)$	data output effective time after WR		20			ns
$t_d(\phi-RW)$	R/ \overline{W} delay time after ϕ				120	ns
$t_d(\phi-SYNC)$	SYNC delay time after ϕ				120	ns
$t_w(RD)$	\overline{RD} pulse width		170			ns
$t_w(WR)$	\overline{WR} pulse width		170			ns

**M37450S1SP/FP, M37450S2SP/FP
M37450S4SP/FP**

MITSUBISHI (MICMPTR/MIPRC) 61E D

8-BIT CMOS MICROCOMPUTER

TEST CONDITION

Input voltage level : V_{IH} 2.4V
 V_{IL} 0.45V
 Output test level : V_{OH} 2.0V
 V_{OL} 0.8V

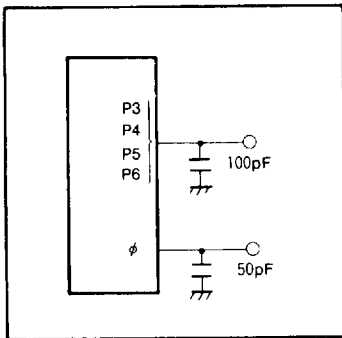

Fig. 3 Test circuit in single-chip mode

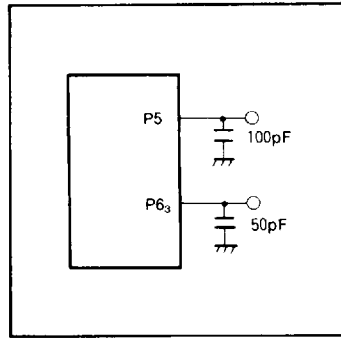

Fig. 4 Master CPU bus interface test circuit

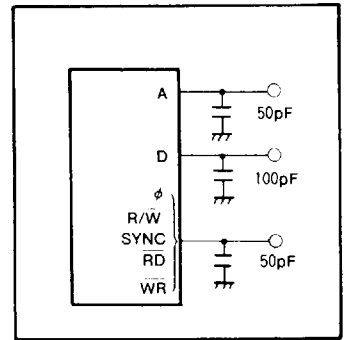

Fig. 5 Local bus test circuit

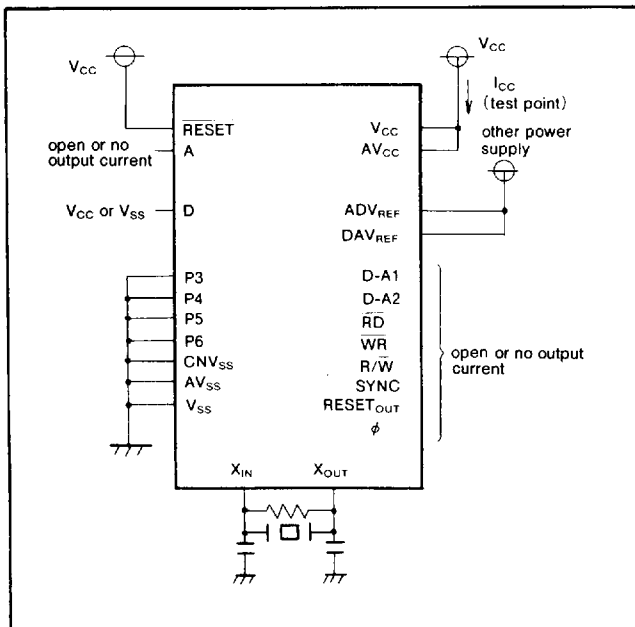
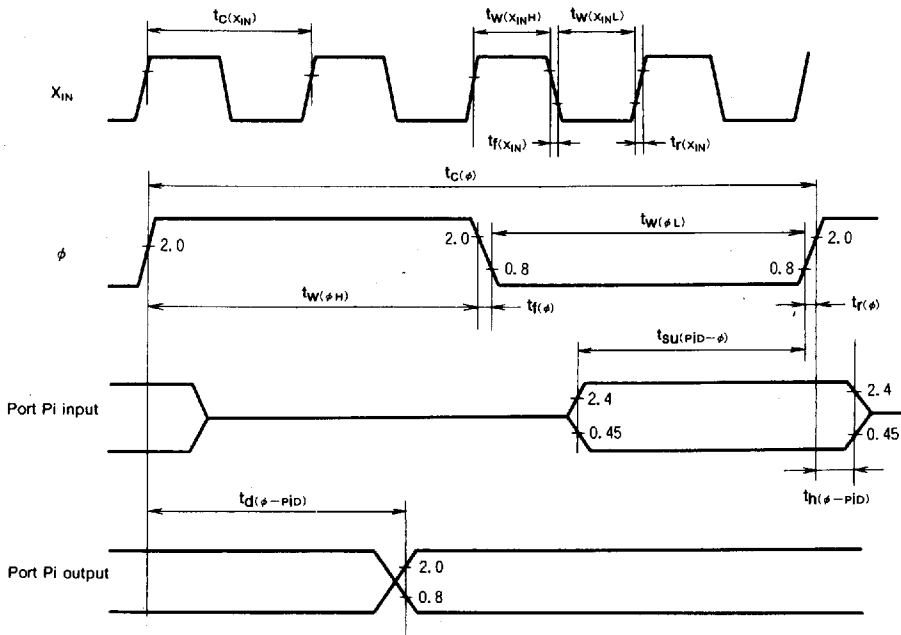

Fig. 6 I_{CC} (at stop mode) test condition

TIMING DIAGRAM

Port/single-chip mode timing diagram



Note : $V_{IH}=0.8V_{CC}$, $V_{IL}=0.16V_{CC}$ of X_{IN}

Master CPU bus interface/ R and W separation type timing diagram

Read

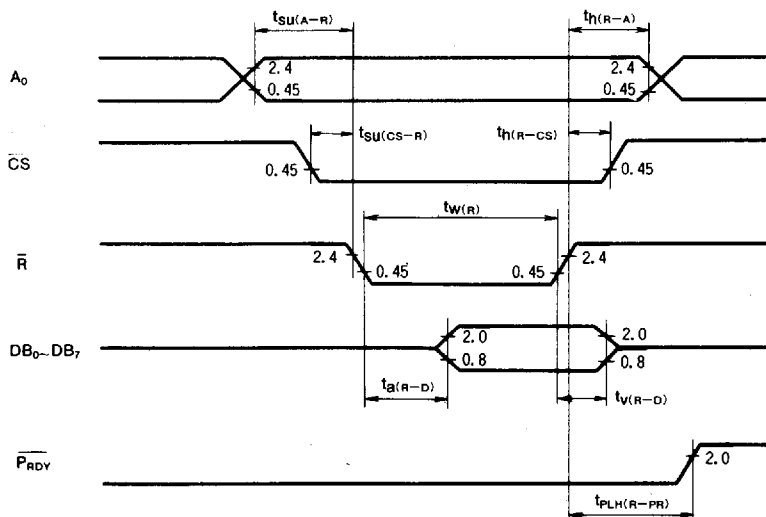

Write

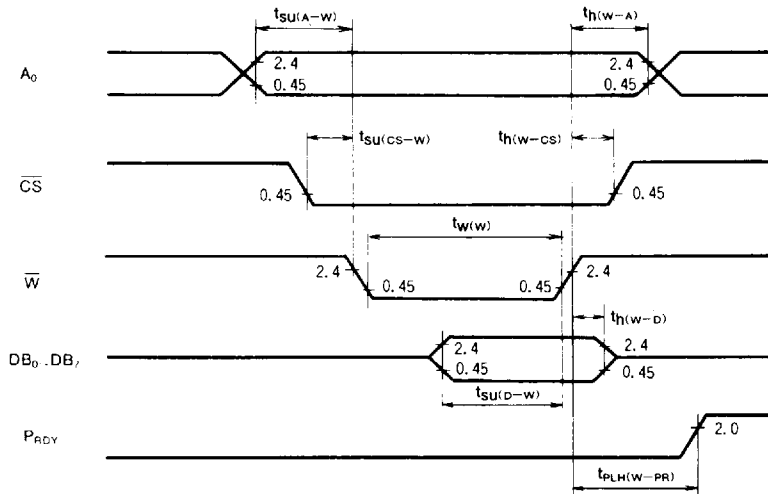

Master CPU interface/ R/W type timing diagram

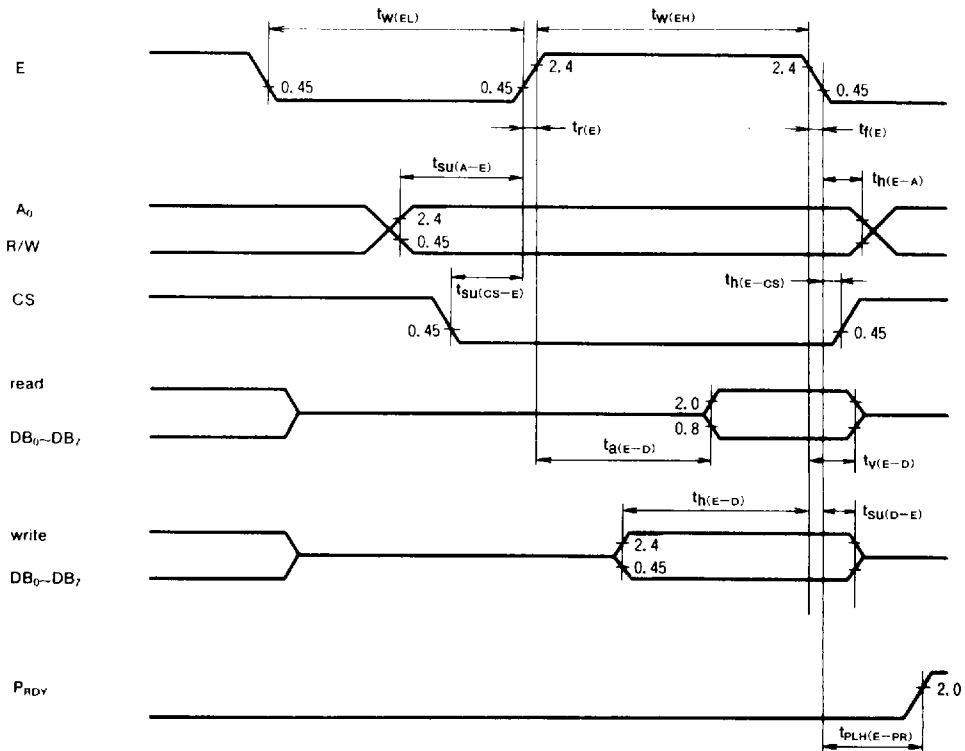

**M37450S1SP/FP, M37450S2SP/FP
M37450S4SP/FP**

MITSUBISHI (MICMPTR/MIPRC) 61E D

8-BIT CMOS MICROCOMPUTER

Local bus timing diagram

