

MITSUBISHI <CONTROL / DRIVER IC>

M54122L

EARTH LEAKAGE CURRENT DETECTOR

DESCRIPTION

The M54122L is a semiconductor integrated circuit with amplifier for a high-speed earth leakage circuit breaker.

FEATURES

- Suitable for JIS C 8371
- Good temperature characteristics of input sensitivity current
- High input sensitivity ($V_T = 13.5\text{mV Typ.}$)
- Low external component count
- High noise and surge-proof
- Low power dissipation ($P_d = 5\text{mW Typ.}$) and may be used both as 100V and 200V.
- High mounting density by SIL package with 8 pins
- Wide temperature range ($T_a = -20 - +80^\circ\text{C}$)

APPLICATION

High speed earth leakage circuit breaker

FUNCTION

The M54122L circuit for the amplifying parts of earth leakage circuit breaker consists of differential amplifier, latch circuit and voltage regulator. It is connected to the secondary side of the zero-current transformer (ZCT) which detects leakage current in the both input of the differential amplifier. Signals amplified by differential amplifier are integrated by an external capacitor, and connects to the input terminal of latch circuit with output suitable for the characteristics of high-speed earth leakage circuit breaker. Latch circuit keeps low in the output till the input voltage reaches the fixed level, and output becomes high when the leakage current more than fixed flows. It drives a thyristor connected to the output terminal of latch circuit.

PIN CONFIGURATION (TOP VIEW)

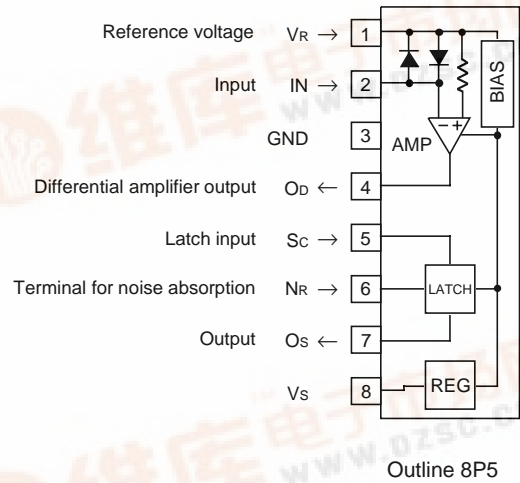

BLOCK DIAGRAM

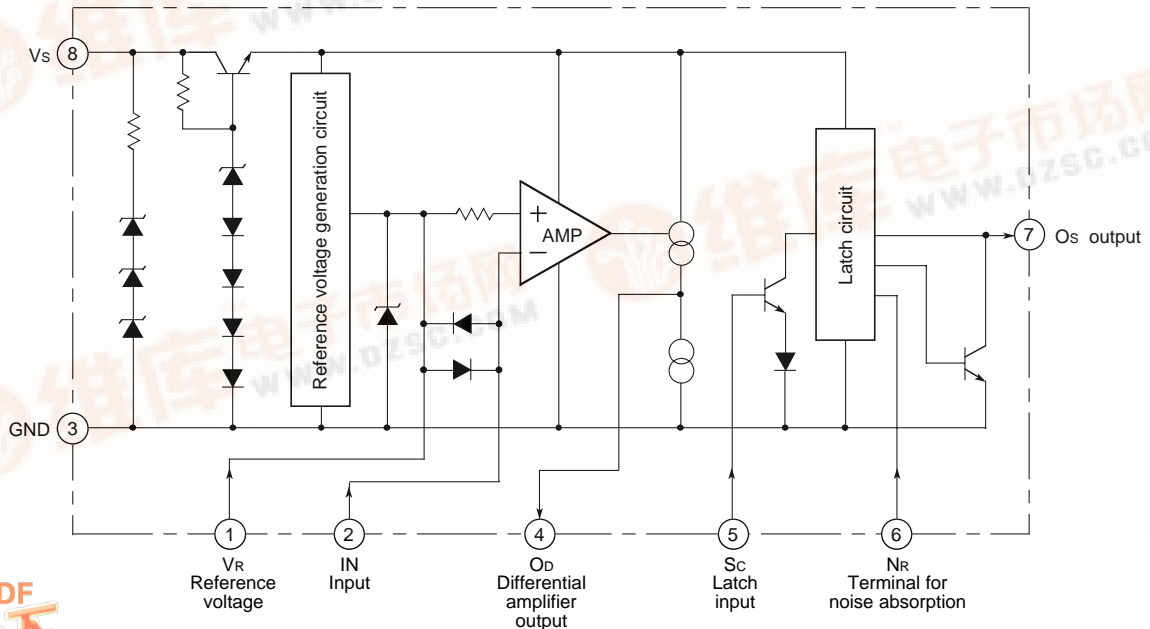

EARTH LEAKAGE CURRENT DETECTOR**ABSOLUTE MAXIMUM RATINGS** (Ta = -20 – 80°C unless otherwise noted)

Symbol	Parameter	Conditions	Ratings	Unit
Is	Supply current		8	mA
I _{VR}	V _R terminal current	Between V _R -IN (Note 1)	250	mA
		Between V _R -GND	30	
		Between IN-V _R (Note 1)	-250	
I _{IN}	IN terminal current	Between IN-V _R (Note 1)	250	mA
		Between IN-GND	30	
		Between V _R -IN (Note 1)	-250	
I _{SC}	Sc terminal current		5	mA
P _d	Power dissipation		200	mW
T _{opr}	Operating temperature		-20 – 80	°C
T _{stg}	Storage temperature		-55 – 125	°C

Note 1: Current value between V_R and IN, and between IN and V_R is less than 1ms in the pulse width, and duty cycle is less than 12%. In applying AC current continuously, it is 100mA_{rms} in the off-state.

Remarks: GND terminal (pin ③) of the circuit is a basis of all the voltages except differential input clamp voltage of DC electrical characteristics, and direction of current is plus (no signal) in flowing into the circuit and is minus (- signal) in flowing out of it. Maximum value and minimum one are shown as absolute value. Please don't apply voltage whose standard is GND terminal in V_R and IN pin.

RECOMMENDED OPERATING CONDITIONS (Ta = -20 – 80°C unless otherwise noted)

Symbol	Parameter	Limits			Unit
		Min.	Typ.	Max.	
V _s	Supply voltage when latch circuit is off-state.	12			V
C _{vs}	External capacitor between V _s and GND	1			μF
C _{os}	External capacitor between O _s and GND			1	μF

ELECTRICAL CHARACTERISTICS (Ta = -20 – 80°C unless otherwise noted)

Symbol	Parameter	Test conditions	Temperature(°C)	Test circuit	Limits			Unit	
					Min.	Typ.*	Max.		
I _{S1}	Supply current	V _S = 12V, V _R -V _I = 30mV	-20	1			580	μA	
			25	1		400	530		
			80	1			480		
V _T	Trip voltage	V _S = 16V, V _R -V _I (Note 2)	-20 – +80	2	10	13.5	17	mV _{rms}	
I _{TD1}	Timed current 1	V _S = 16V, V _R -V _I = 30mV V _{OD} = 1.2V	25	3	-12		-30	μA	
I _{TD2}	Timed current 2	V _S = 16V, short circuit between V _R and V _I , V _{OD} = 0.8V	25	4	17		37	μA	
I _O	Output current	V _{SC} = 1.4V V _{OS} = 0.8V		Is1 = 580μA	-20	5	-200		μA
				Is1 = 530μA	25	5	-100		
				Is1 = 480μA	80	5	-75		
V _{SC} "ON"	Sc ON voltage (Note 3)	V _S = 16V	25	6	0.7		1.4	V	
I _{SC} "ON"	Sc input current	V _S = 12V	25	7			5	μA	
I _{OSL}	Output low-level current	V _S = 12V, V _{OSL} = 0.2V	-20 – +80	8	200			μA	
V _{IC}	Input clamp voltage	V _S = 12V, I _{IC} = 20mA	-20 – +80	9	4.3		6.7	V	
V _{IDC}	Differential input clamp voltage	I _{IDC} = 100mA	-20 – +80	10	0.4		2	V	
V _{SM}	Maximum current voltage	I _{SM} = 7mA	25	11	20		28	V	
I _{S2}	Supply current 2 (Note 4)	V _R -V _I V _{OS} = 0.6V (Note 5)	-20 – +80	12			900	μA	
V _S "OFF"	Latch circuit off-state supply voltage (Note 6)		25	13	0.5			V	
T _{ON}	Operating time (Note 7)	V _S = 16V, V _R -V _I = 0.3V	25	14	2		4	ms	

*: Typical values are at Ta = 25°C.

Note 2: When standard value of voltage (60Hz) between V_R and V_I is minimum, and output O_s is low-level, or when standard value of voltage (60Hz) between V_R and V_I is maximum, and output O_s is high-level, it is considered as a good one.

3: When standard value of voltage V_{SC} "ON" is minimum, and output O_s is low-level, or when standard value of voltage V_{SC} "ON" is maximum, and output O_s is high-level, it is considered as a good one.

4: Supply current 2 is necessary to keep high in output O_s.

5: After applying 30mV between V_R and V_I and shorting between them, it is considered as a good one if standard value of I_{GT} flows out of output O_s.

6: After supply voltage applies 12V and output O_s is high-level, it is considered as a good one in the standard value of supply voltage and in the low-level of output O_s.

7: Operating time is a time from applying fixed input till operating latch circuit in 0.047μF between O_D and GND.

TEST CIRCUIT

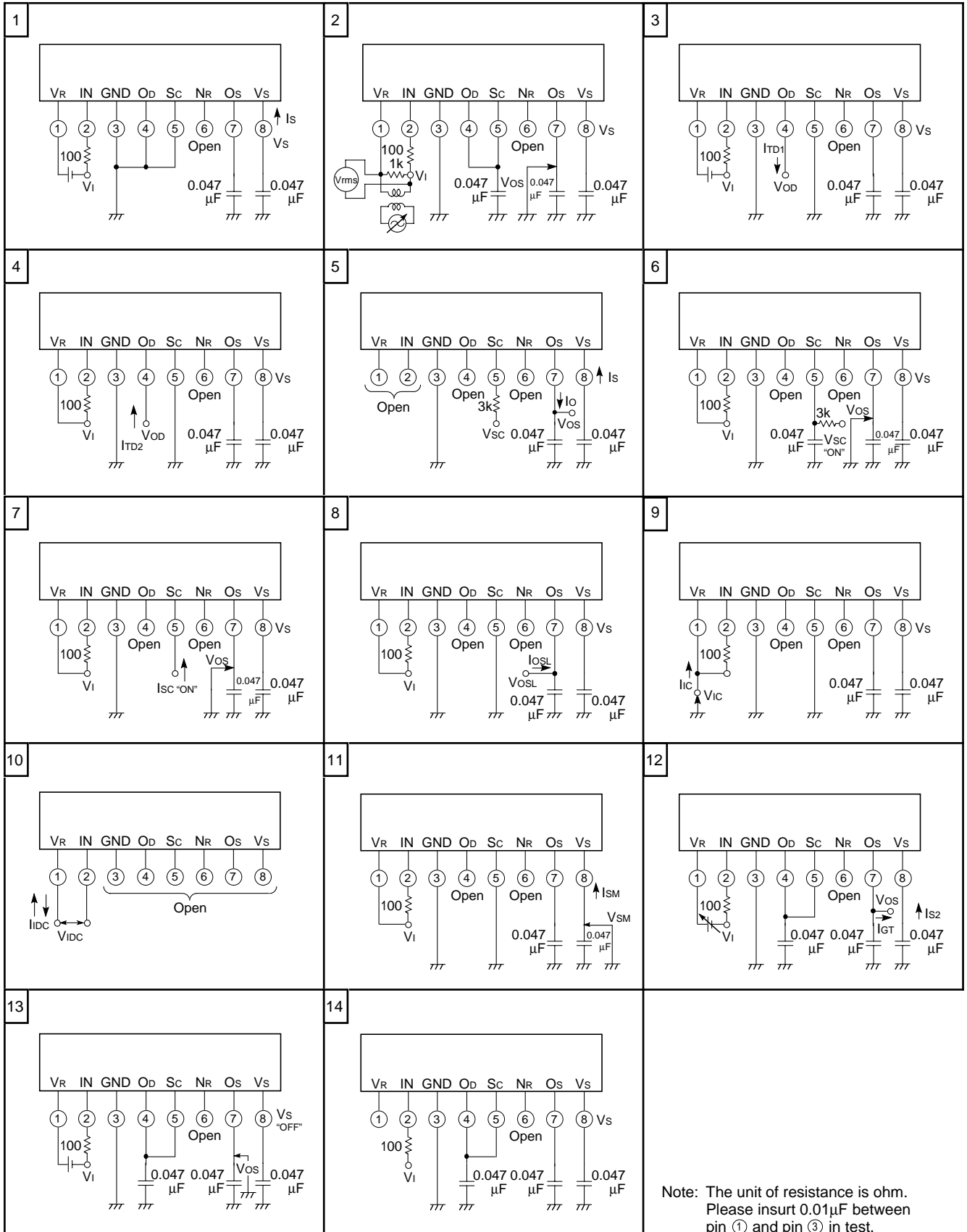

Note: The unit of resistance is ohm.
Please insert 0.01μF between pin ① and pin ③ in test.

TYPICAL CHARACTERISTICS

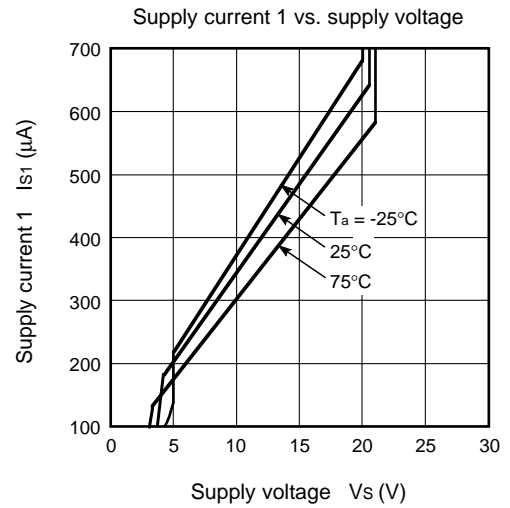
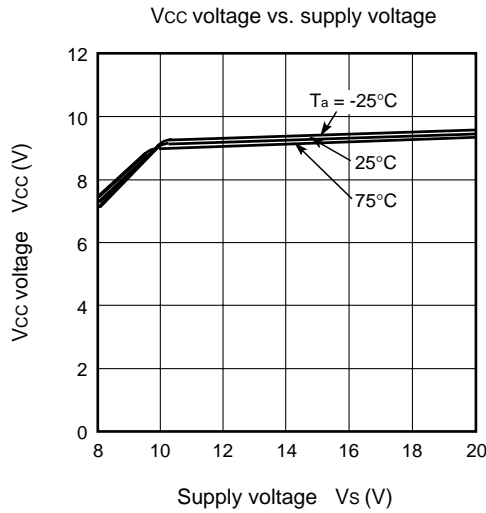

Vcc voltage generates by the constant voltage circuit in IC. This is measured not by M54122L but by a special element.

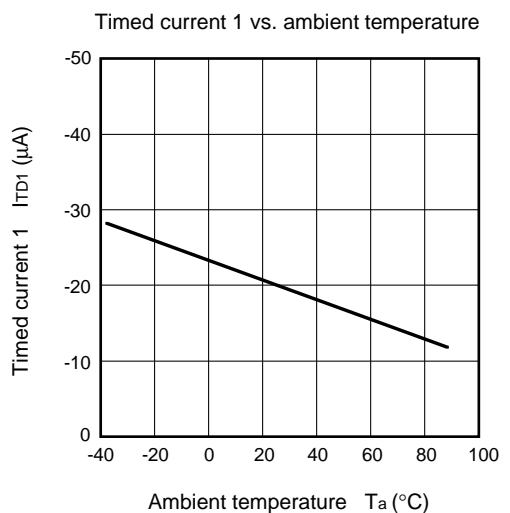
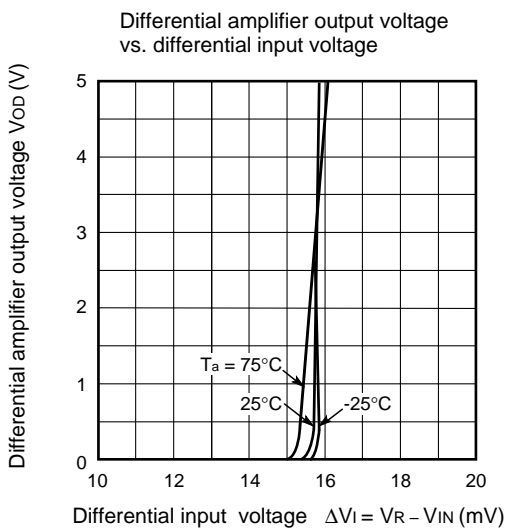
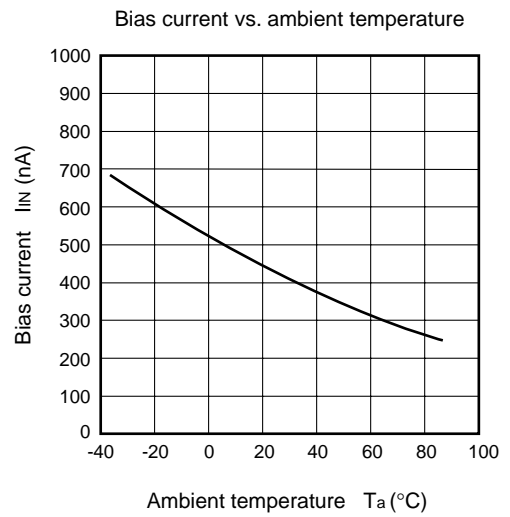
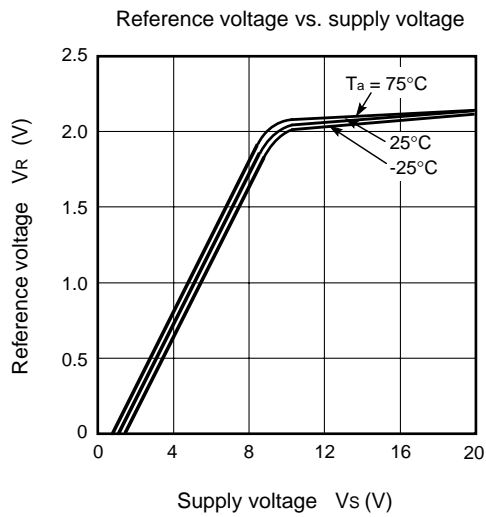

Os voltage vs. Sc voltage

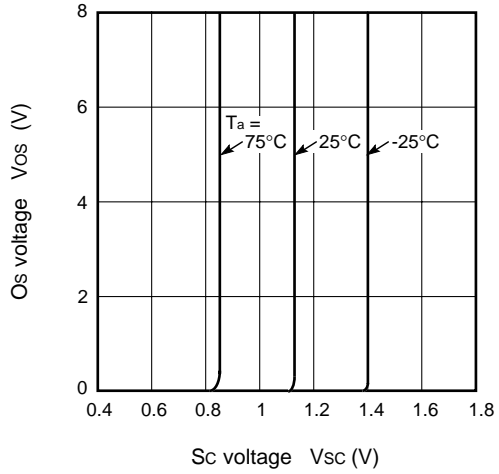

Operating time vs. ambient temperature

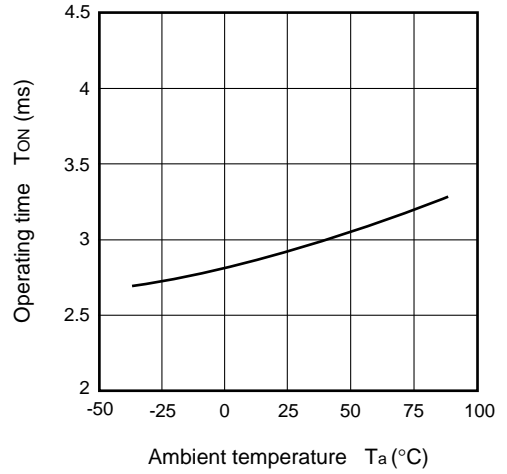

Output current vs. Os output voltage

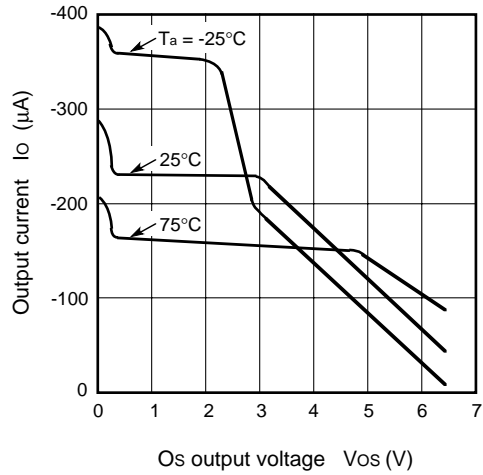

Trip voltage vs. ambient temperature

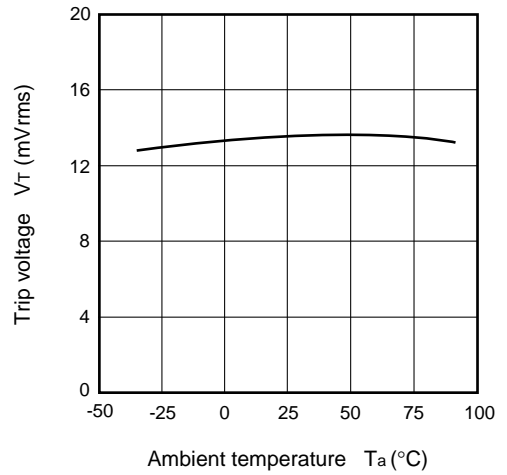

APPLICATION EXAMPLE

• HIGH-SPEED LEAKAGE CIRCUIT BREAKER WITH M54122L

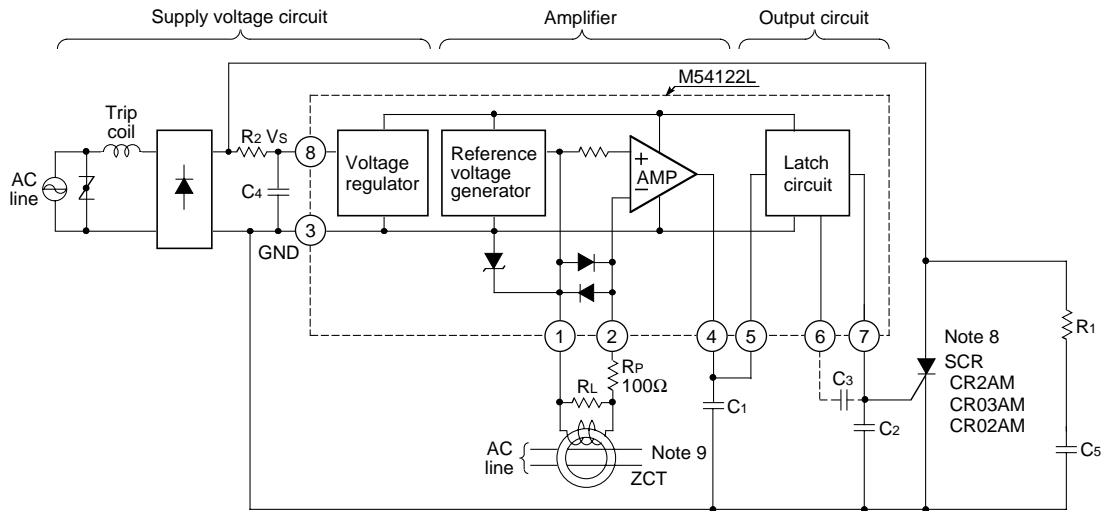

Note 8 : Gate current must be selected.
 Please select voltage resistance by AC supply voltage.
 9 : MZ Core Series by Soryo Denshi Kagaku Co., Ltd (Mitsubishi Subsidiary)
 Tel. +81-427-74-7813

Supply voltage circuit is connected as a previous diagram. Please decide constants R_1 , R_2 , C_4 , and C_5 of a filter in order to keep at least 12V in V_s , when normal supply current flows.

In this case, please connect C_4 (more than $1\mu\text{F}$) and C_2 (less than $1\mu\text{F}$). ZCT and load resistance R_L of ZCT are connected between input pin ① and ②. In this case protective resistance ($R_P = 100\Omega$) must be insured. Sensitivity current is regulated by R_L , and output of amplifier shows in pin ④. External capacitor C_1 between pin ④ and GND is used for noise removal.

When large current is grounded in the primary side (AC line) of ZCT, the wave form in the secondary side of ZCT is distorted and some signals doesn't appear in the output of amplifier. So please connect a varistor or a diode (2 pcs.) to ZCT in parallel.

Latch circuit is used to inspect the output level of amplifier and to supply gate current on the external SCR. When input pin becomes more than 1.1V (Typ.), latch circuit operates and supply gate current in the gate of SCR connected to the output pin ⑦.

Pin ⑥ can be used in the open state, but please connect capacitor (about $0.047\mu\text{F}$) between pin ⑥ and pin ⑦.

Operating time vs. input voltage

