

MITSUBISHI BIPOLAR DIGITAL ICs

MITSUBISHI ELEK {LINEAR} 80 DE 6249826 0009208 8 **M54521P**

6249826 MITSUBISHI ELEK (LINEAR) 80C 09208 0 *T-43-25*

5-UNIT 500mA DARLINGTON TRANSISTOR ARRAY

DESCRIPTION

The M54521P, 5-channel sink driver, consists of 10 NPN transistors connected to form high current gain driver pairs.

FEATURES

- Output sustaining voltage to 30V
- High output sink current to 500mA
- Wide operating temperature range ($T_a = -20 \sim +75^\circ\text{C}$)

APPLICATION

Relay and printer drivers, LED or incandescent display digit driver, interfacing for standard MOS/BIPOLAR logics

FUNCTION

The M54521P is comprised of five NPN darlington driver pairs. All emitters and the substrate are connected together to pin 7. The output are capable of sinking 500mA and will withstand 30V in the OFF state.

PIN CONFIGURATION (TOP VIEW)

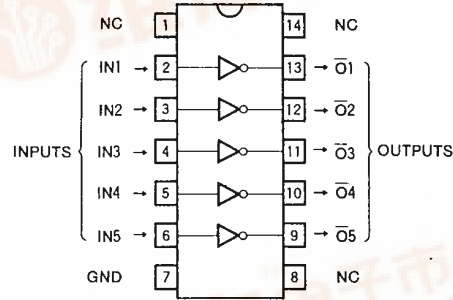

Outline 14P4

NC : NO CONNECTION

CIRCUIT SCHEMATIC

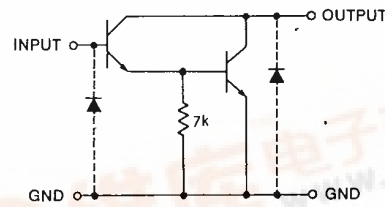

Unit : Ω

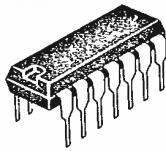

14-pin molded plastic DIP

ABSOLUTE MAXIMUM RATINGS ($T_a = -20 \sim +75^\circ\text{C}$, unless otherwise noted)

Symbol	Parameter	Conditions	Ratings	Unit
V_{CE0}	Output sustaining voltage	Transistor OFF	-0.5 ~ +30	V
I_c	Collector current	Transistor ON	500	mA
P_d	Power dissipation	$T_a = 25^\circ\text{C}$	1.47	W
T_{opr}	Operating ambient temperature range		-20 ~ +75	$^\circ\text{C}$
T_{stg}	Storage temperature range		-55 ~ +125	$^\circ\text{C}$



MITSUBISHI ELEK (LINEAR) 80 DE 6249826 0009209 0 M54521P

6249826 MITSUBISHI ELEK (LINEAR) 80C 09209 0 T-43-25

5-UNIT 500mA DARLINGTON TRANSISTOR ARRAY

RECOMMENDED OPERATIONAL CONDITIONS ($T_a = -20 \sim +75^\circ\text{C}$, unless otherwise noted)

Symbol	Parameter		Limits			Unit
			Min	Typ	Max	
V_O	Output voltage		0		30	V
I_C	Collector current per channel	Percent duty cycle less than 10%	0		400	mA
		Percent duty cycle less than 55%	0		200	
I_{IH}	"H" Input current	$I_C = 200\text{mA}$	1		5	mA
		$I_C = 400\text{mA}$	2		5	
I_{IL}	"L" Input current			0		μA

ELECTRICAL CHARACTERISTICS ($T_a = -20 \sim +75^\circ\text{C}$, unless otherwise noted)

Symbol	Parameter	Test conditions	Limits			Unit
			Min	Typ*	Max	
$V_{(BR)CEO}$	Output sustaining voltage	$I_{CEO} = 100\mu\text{A}$	30			V
$V_{CE(sat)}$	Output saturation voltage	$V_I = 2\text{mA}, I_C = 400\text{mA}$		1.0	2.4	V
		$V_I = 1\text{mA}, I_C = 200\text{mA}$		0.8	1.6	
V_I	Input voltage	$I_I = 1\text{mA}$	0.6	1.35	1.7	V

* : A typical value is at $T_a = 25^\circ\text{C}$.

TYPICAL CHARACTERISTICS

ALLOWABLE AVERAGE POWER DISSIPATION

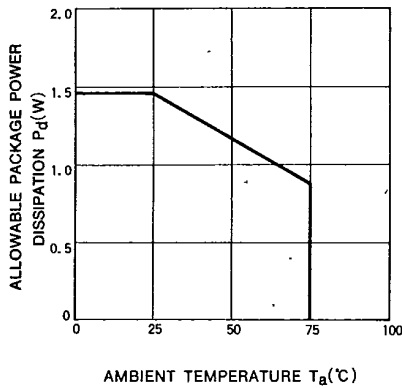

OUTPUT CURRENT CHARACTERISTICS

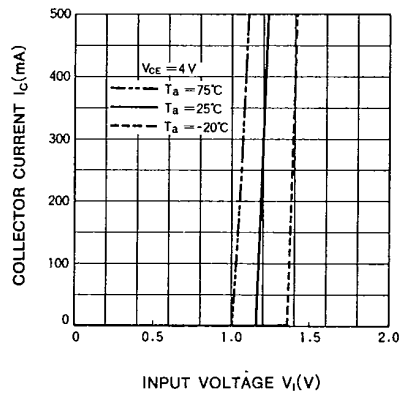

MITSUBISHI ELEK (LINEAR) 80 DE 6249826 0009210 6 M54521P

6249826 MITSUBISHI ELEK (LINEAR) 80C 09210 D 7-43-25

5-UNIT 500mA DARLINGTON TRANSISTOR ARRAY

ALLOWABLE COLLECTOR CURRENT AS A FUNCTION OF DUTY CYCLE

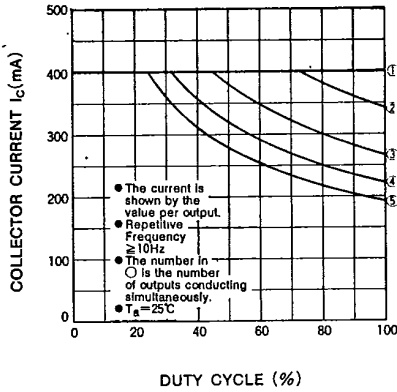

ALLOWABLE COLLECTOR CURRENT AS A FUNCTION OF DUTY CYCLE

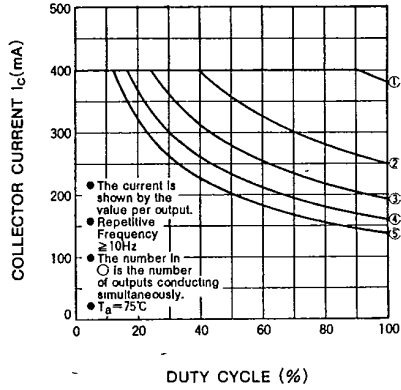

DC CURRENT GAIN CHARACTERISTICS

