

MITSUBISHI BIPOLAR DIGITAL ICs

M54654P

MITSUBISHI (DGTL LOGIC) 3LE D ■ 6249827 0014637 4 ■ MIT3
QUADRUPLE LINE RECEIVER

DESCRIPTION

The M54654P is a semiconductor integrated circuit containing a line receiver suitable for use as an interface between data terminals and data transmitters.

FEATURES

- Meets all the specifications set by JIS C 6361 and EIA Standard RS-232-C.
- Supply voltage can be either a 5V or 12V.
- Input resistance ($R_i=5k\Omega$ typ.)
- Wide output voltage range ($V_o=-25\sim+25V$)
- When input A is open, output Y is H (in case of Fail-safe Operation).
- Hysteresis possible when in normal operation
- Output can be directly connected to TTL.

APPLICATION

Interface between data terminal equipment and data transmitter equipment
 Level converter

FUNCTION

Containing 4 line receivers with Schmitt circuits and inverters, this unit is suitable, like the line driver M54650P, as an interface IC in data transmission systems. It meets the specifications of both JIS C 6361 and EIA Standard RS-232-C. It can also be used as a level converter.

This receiver can use a 5V voltage source but, as a constant-voltage circuit is included in the IC, it can operate on 12V also. In order to satisfy the above forementioned specifications it also has a fail-safe function. Hysteresis varies when in fail-safe operation and when in normal operation. Output can be connected directly with DTL and TTL.

FUNCTION TABLE

A	Y
L	H
H	L

- Note 1 : When using V_{CC1} (pin⑩), V_{CC2} (pin⑯) is either open or connected to V_{CC1} .
 2 : When using V_{CC2} , V_{CC1} is either open or connected to threshold pin.

ABSOLUTE MAXIMUM RATINGS ($T_a=0\sim75^\circ C$, unless otherwise noted)

Symbol	Parameter	Conditions	Limits	Unit
V_{CC1}	Supply voltage		7	V
V_{CC2}	Supply voltage		14	V
V_i	Input voltage		± 25	V
V_o	Output voltage		V_{CC1}	V
P_d	Power dissipation		500	mW
T_{opr}	Operating free-air ambient temperature range		0~75	$^\circ C$
T_{stg}	Storage temperature range		-65~+150	$^\circ C$

T-7545-05

PIN CONFIGURATION (TOP VIEW)

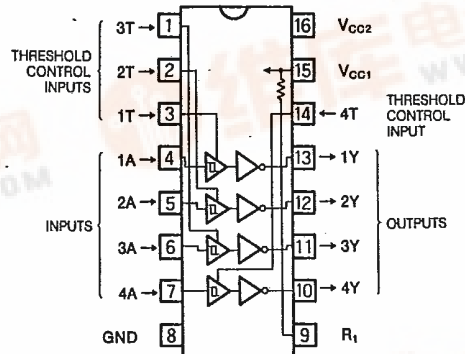

Outline 16P4

CIRCUIT SCHEMATIC (EACH CIRCUIT)

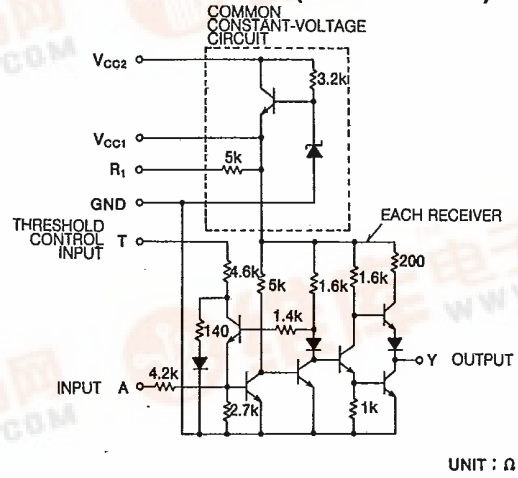

UNIT : Ω

RECOMMENDED OPERATING CONDITIONS ($T_a = 0 \sim 75^\circ\text{C}$, unless otherwise noted)

Symbol	Parameter	Limits			Unit
		Min	Typ	Max	
V_{CC1}	Supply voltage	4.5	5	5.5	V
V_{CC2}	Supply voltage	10.8	12	13.2	V
V_I	Input voltage			± 15	V
F_O	Fan out			10	V

ELECTRICAL CHARACTERISTICS ($T_a = 0 \sim 75^\circ\text{C}$, unless otherwise noted)

Symbol	Parameter	Test conditions	Limits			Unit	Test circuit
			Min	Typ	Max		
V_{IH}	High-level input voltage		3			V	
V_{IL}	Low-level input voltage				-3	V	
V_{T+}	Positive-going threshold voltage	Normal	0.8	2	3	V	1
		Fall-safe					
V_{T-}	Negative-going threshold voltage	Normal	-3	-1.2	0	V	2
		Fall-safe	0.4	1.1	2.6	V	
$V_{T+} - V_{T-}$	Hysteresis	Normal	0.8	3.3	6	V	
		Fall-safe	0	1.1	2.6	V	
V_{OH}	High-level output voltage	$I_{OH} = -400\mu\text{A}, V_I = -3\text{V}$	2.4	3.5		V	1
	Fall-safe	$I_{OH} = -400\mu\text{A}, V_I = \text{Open}$	2.4	3.5		V	
V_{OL}	Low-level output voltage	$I_{OL} = 16\text{mA}, V_I = 3\text{V}$		0.23	0.4	V	2
r_i, R_i	Input impedance	$-25 \leq V_I \leq -14$	3	5	7	k Ω	3
		$-14 \leq V_I \leq -3$	3	5	7	k Ω	
		$-3 < V_I < 3$	3	6	8	k Ω	
		$3 \leq V_I \leq 14$	3	5	7	k Ω	
		$14 \leq V_I \leq 25$	3	5	7	k Ω	
$V_{I(\text{OPEN})}$	Open input voltage	$I_i = 0\text{mA}$	0	0.2	2	V	4
I_{OS}	Short-circuit output current (Note 3)	$V_{CC1} = 5.5\text{V}, V_O = 0\text{V}$	-10	-20	-40	mA	5
I_{CC1}	Supply current	$V_{CC1} = 5.5\text{V}, T_a = 25^\circ\text{C}$		20	35	mA	6
I_{CC2}	Supply current	$V_{CC2} = 13.2\text{V}, T_a = 25^\circ\text{C}$		23	40	mA	

* : All typical values are $V_{CC1} = 5\text{V}, T_a = 25^\circ\text{C}$. Note 3 : Test in as short a time as possible and do not test more than 2 outputs at same time.

SWITCHING CHARACTERISTICS ($V_{CC1} = 5\text{V}, T_a = 25^\circ\text{C}$, unless otherwise noted)

Symbol	Parameter	Test conditions	Limits			Unit	Test circuit
			Min	Typ	Max		
t_{PLH}	Low-to-high-level, high-to-low-level output propagation time; from Input A to output Y	$C_L = 50\text{pF}, R_L = 390\Omega$		22		ns	Note 4
t_{PHL}				20		ns	
t_{TLH}	Low-to-high-level, high-to-low-level output transition time			9		ns	
t_{THL}				6		ns	

TIMING DIAGRAM (Reference level = 1.5V)

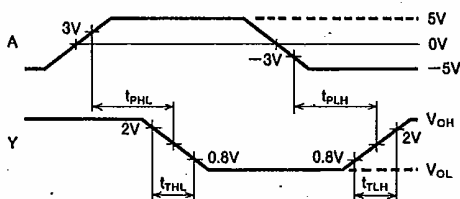

Note 4 : Test circuit

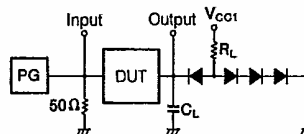

1. The pulse generator (PG) characteristics : $t_r = 10\text{ns}, t_f = 10\text{ns}, \text{PRR} = 1\text{MHz}, t_{PW} = 200\text{ns}, V_p = 10\text{V}_{p-p}$.
2. All diodes used are high-speed switching diodes ($t_{rr} \leq 4\text{ns}$).
3. C_L includes probe and jig capacitance.

TEST CIRCUITS

1

TEST PARAMETER	A	T	Y	Vcc1 (PIN⑨)	Vcc2 (PIN⑩)	
INPUT OPEN	V _{OH}	OPEN	OPEN	I _{OH}	4.5V	OPEN
(Fail-safe)	V _{OH}	OPEN	OPEN	I _{OH}	OPEN	10.8V
V _{t+} -SMALLEST	V _{OH}	0.8V	OPEN	I _{OH}	5.5V	OPEN
V _{t+} -SMALLEST (Fail-safe)	V _{OH}	0.8V	OPEN	I _{OH}	OPEN	13.2V
V _{t+} -SMALLEST (Normal)	V _{OH}	*	PIN⑨	I _{OH}	5.5V, T	OPEN
(Normal)	V _{OH}	*	PIN⑩	I _{OH}	T	13.2V
V _{t+} -LARGEST	V _{OH}	-3V	PIN⑩	I _{OH}	5.5V, T	OPEN
(Normal)	V _{OH}	-3V	PIN⑨	I _{OH}	T	13.2V

* : AFTER MOMENTARILY APPLYING -5V, APPLY 0.8V.

2

TEST PARAMETER	A	T	Y	Vcc1 (PIN⑨)	Vcc2 (PIN⑩)	
V _{t+} -SMALLEST	V _{OL}	3V	OPEN	I _{OL}	4.5V	OPEN
V _{t+} -LARGEST (Fail-safe)	V _{OL}	3V	OPEN	I _{OL}	OPEN	10.8V
V _{t+} -SMALLEST (Normal)	V _{OL}	3V	PIN⑩	I _{OL}	4.5V, T	OPEN
(Normal)	V _{OL}	3V	PIN⑨	I _{OL}	T	10.8V
V _{t+} -LARGEST	V _{OL}	*	PIN⑩	I _{OL}	5.5V, T	OPEN
(Normal)	V _{OL}	*	PIN⑨	I _{OL}	T	13.2V

* : AFTER MOMENTARILY APPLYING 5V, SHORT TO GROUND.

3

T	Vcc1 (PIN⑨)	Vcc2 (PIN⑩)
OPEN	5V	OPEN
OPEN	GND	OPEN
OPEN	OPEN	OPEN
PIN⑩	T, 5V	OPEN
GND	GND	OPEN
OPEN	OPEN	12V
OPEN	OPEN	GND
PIN⑩	T	12V
PIN⑩	T	GND
PIN⑩	T	OPEN

$-R_1 = \frac{V_i}{I_i}, r_1 = \frac{\Delta V_i}{\Delta I_i}$

4

T	Vcc1 (PIN⑨)	Vcc2 (PIN⑩)
OPEN	5.5V	OPEN
PIN⑩	5.5V	OPEN
OPEN	OPEN	13.2V
PIN⑩	T	13.2V

5

6

MEASURE ALL FOUR CIRCUITS AT SAME TIME.

TYPICAL CHARACTERISTICS

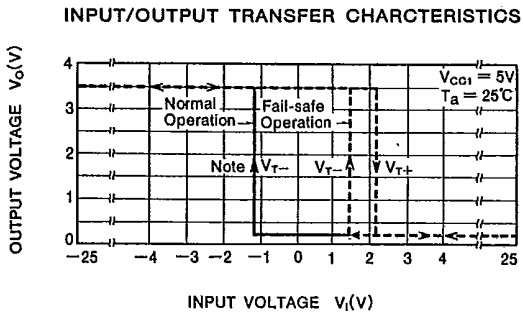

INPUT CURRENT VS INPUT VOLTAGE

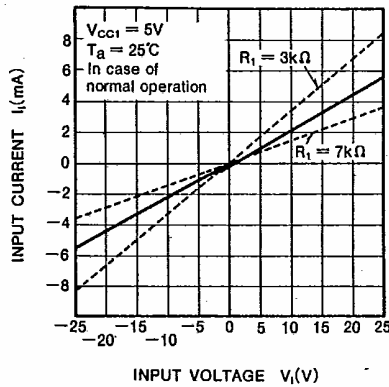

Note 4 : In case of normal operation, connect all threshold pins to V_{CC1} .

5 : In case of fail-safe operation, leave all threshold pins open.

APPLICATION EXAMPLES

DATA TRANSMISSION SYSTEM

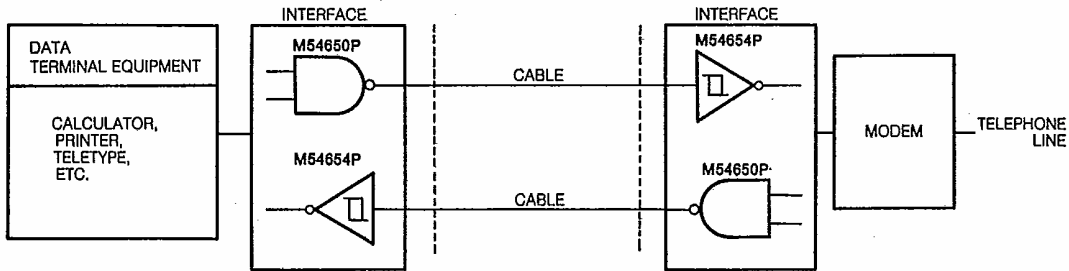

TRANSMISSION SPEED : 20k BITS/SEC (IN CASE OF CABLE WITH EQUIVALENT FULL 2500pF LOAD)

HYSTERESIS REDUCTION

In normal operation it is possible to reduce the width of hysteresis by decreasing negative going threshold voltage $|V_{T-}|$. $|V_{T-}|$ can be decreased by externally placing a resistor between threshold control pin (T) and V_{CC1} . The larger the resistor the smaller $|V_{T-}|$. Included in the IC is a $5k\Omega$ (connected to R_1 pin) which can be used as R_v .

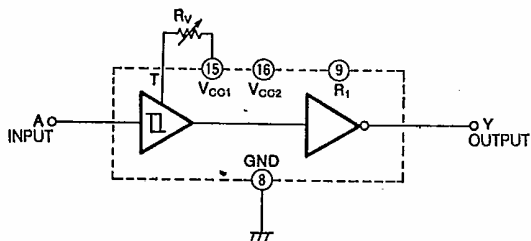

INPUT/OUTPUT TRANSFER CHARACTERISTICS

