



**M54HC109**  
**M74HC109**

## DUAL J-K FLIP FLOP WITH PRESET AND CLEAR

- HIGH SPEED  
 $f_{MAX} = 63 \text{ MHz (TYP.) AT } V_{CC} = 5 \text{ V}$
- LOW POWER DISSIPATION  
 $I_{CC} = 2 \mu\text{A (MAX.) AT } T_A = 25 \text{ }^\circ\text{C}$
- HIGH NOISE IMMUNITY  
 $V_{NIH} = V_{NIL} = 28 \% V_{CC} \text{ (MIN.)}$
- OUTPUT DRIVE CAPABILITY  
10 LSTTL LOADS
- SYMMETRICAL OUTPUT IMPEDANCE  
 $|I_{OH}| = I_{OL} = 4 \text{ mA (MIN.)}$
- BALANCED PROPAGATION DELAYS  
 $t_{PLH} = t_{PHL}$
- WIDE OPERATING VOLTAGE RANGE  
 $V_{CC} \text{ (OPR)} = 2 \text{ V TO } 6 \text{ V}$
- PIN AND FUNCTION COMPATIBLE  
WITH 54/74LS109

### DESCRIPTION

The M54/74HC109 is a high speed CMOS DUAL J-K FLIP-FLOP WITH PRESET AND CLEAR fabricated in silicon gate C<sup>2</sup>MOS technology.

It has the same high speed performance of LSTTL combined with true CMOS low power consumption.

In accordance with the logic level on the J and  $\bar{K}$  input is device changes state on positive going transitions of the clock pulse. CLEAR and PRESET are independent of the clock and accomplished by a low logic level on the corresponding input.

All inputs are equipped with protection circuits against static discharge and transient excess voltage.

### INPUT AND OUTPUT EQUIVALENT CIRCUIT

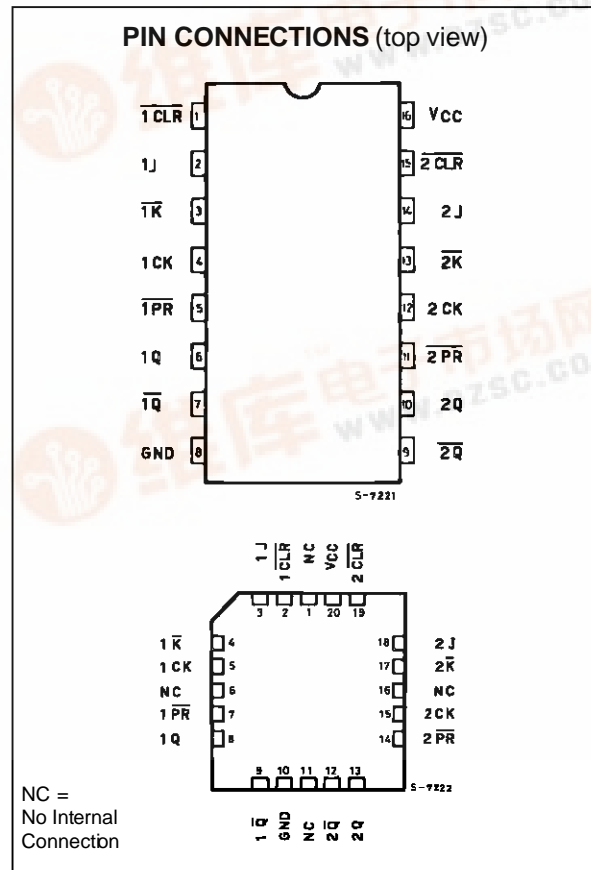
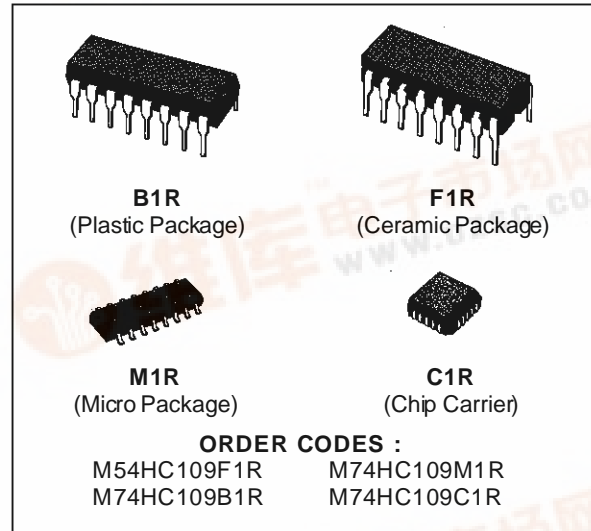
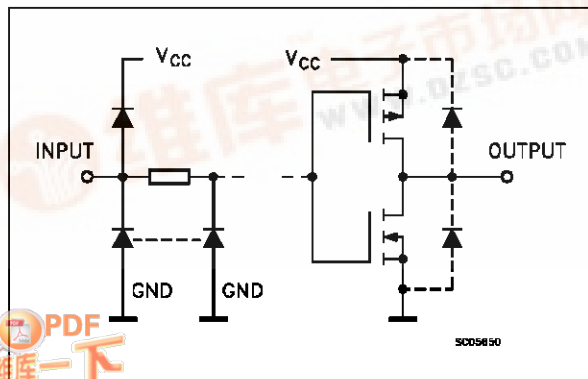

# M54/M74HC109

## PIN DESCRIPTION

PIN No	SYMBOL	NAME AND FUNCTION
1, 15	1CLR, 2CLR	Asynchronous Reset Direct Input
2, 4, 3, 13	1J, 2J, 1K, 2K	Synchronous Inputs; Flip-flops 1 and 2
4, 12	1CK, 2CK	Clock Input
5, 11	1PR, 2PR	Asynchronous Set Direct Input (Active LOW)
6, 10	1Q, 2Q	True Flip-flop Outputs
7, 9	1Q̄, 2Q̄	Complement Flip-flop Outputs
8	GND	Ground (0V)
16	V <sub>CC</sub>	Positive Supply Voltage

## IEC LOGIC SYMBOL

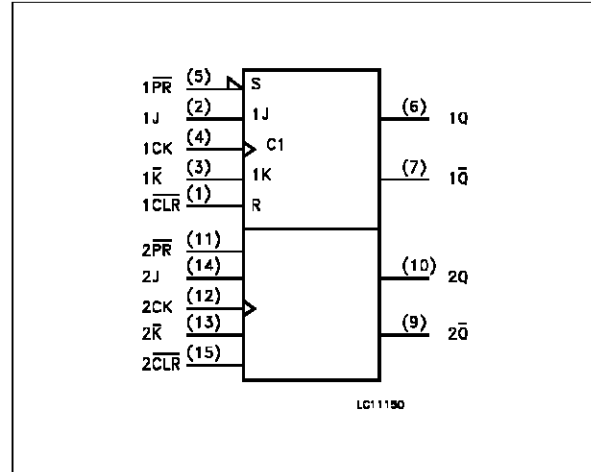

## LOGIC CIRCUIT

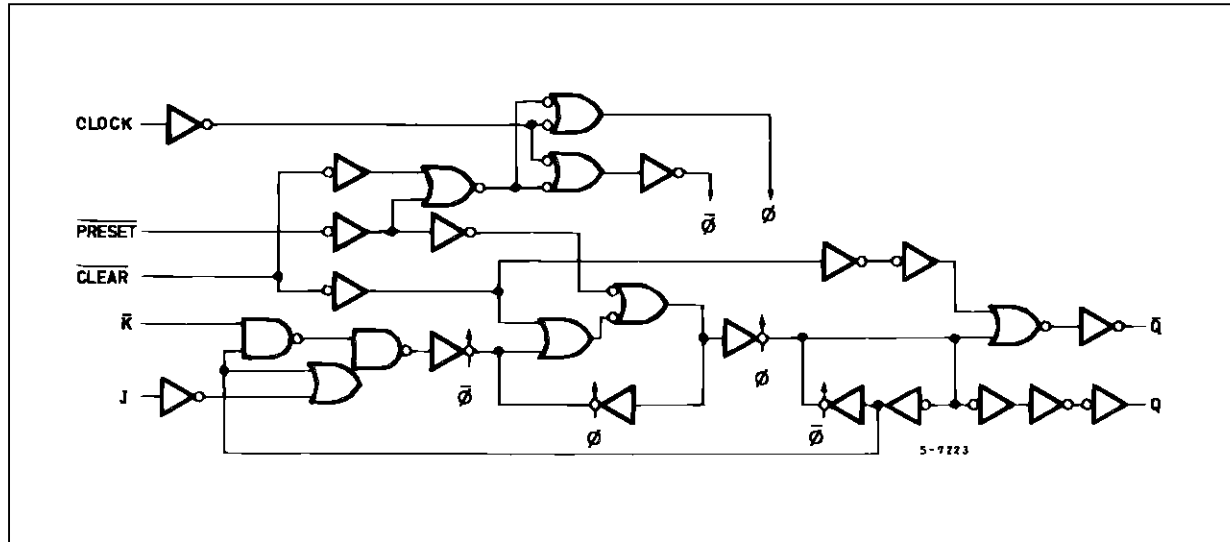

## TRUTH TABLE

INPUTS					OUTPUTS		FUNCTION
CLR	PR	J	K	CK	Q	Q̄	
L	H	X	X	X	L	H	CLEAR
H	L	X	X	X	H	L	PRESET
L	L	X	X	X	H	H	
H	H	L	H	⌋	Q <sub>n</sub>	Q̄ <sub>n</sub>	NO CHANGE
H	H	L	L	⌋	L	H	
H	H	H	H	⌋	H	L	
H	H	H	L	⌋	Q̄ <sub>n</sub>	Q <sub>n</sub>	TOGGLE
H	H	X	X	⌋	Q <sub>n</sub>	Q̄ <sub>n</sub>	NO CHANGE

X = DON'T CARE

**ABSOLUTE MAXIMUM RATINGS**

Symbol	Parameter	Value	Unit
$V_{CC}$	Supply Voltage	-0.5 to +7	V
$V_I$	DC Input Voltage	-0.5 to $V_{CC} + 0.5$	V
$V_O$	DC Output Voltage	-0.5 to $V_{CC} + 0.5$	V
$I_{IK}$	DC Input Diode Current	$\pm 20$	mA
$I_{OK}$	DC Output Diode Current	$\pm 20$	mA
$I_O$	DC Output Source Sink Current Per Output Pin	$\pm 25$	mA
$I_{CC}$ or $I_{GND}$	DC $V_{CC}$ or Ground Current	$\pm 50$	mA
$P_D$	Power Dissipation	500 (*)	mW
$T_{stg}$	Storage Temperature	-65 to +150	$^{\circ}C$
$T_L$	Lead Temperature (10 sec)	300	$^{\circ}C$

Absolute Maximum Ratings are those values beyond which damage to the device may occur. Functional operation under these condition is not implied.  
 (\*) 500 mW:  $\pm 65^{\circ}C$  derate to 300 mW by 10mW/ $^{\circ}C$ : 65  $^{\circ}C$  to 85  $^{\circ}C$

**RECOMMENDED OPERATING CONDITIONS**

Symbol	Parameter	Value	Unit	
$V_{CC}$	Supply Voltage	2 to 6	V	
$V_I$	Input Voltage	0 to $V_{CC}$	V	
$V_O$	Output Voltage	0 to $V_{CC}$	V	
$T_{op}$	Operating Temperature: <b>M54HC Series</b> <b>M74HC Series</b>	-55 to +125 -40 to +85	$^{\circ}C$ $^{\circ}C$	
$t_r, t_f$	Input Rise and Fall Time	$V_{CC} = 2 V$ $V_{CC} = 4.5 V$ $V_{CC} = 6 V$	0 to 1000 0 to 500 0 to 400	ns

## M54/M74HC109

### DC SPECIFICATIONS

Symbol	Parameter	Test Conditions		Value						Unit		
		V <sub>CC</sub> (V)		T <sub>A</sub> = 25 °C 54HC and 74HC			-40 to 85 °C 74HC		-55 to 125 °C 54HC			
				Min.	Typ.	Max.	Min.	Max.	Min.		Max.	
V <sub>IH</sub>	High Level Input Voltage	2.0		1.5			1.5		1.5		V	
		4.5		3.15			3.15		3.15			
		6.0		4.2			4.2		4.2			
V <sub>IL</sub>	Low Level Input Voltage	2.0				0.5		0.5		0.5	V	
		4.5				1.35		1.35		1.35		
		6.0				1.8		1.8		1.8		
V <sub>OH</sub>	High Level Output Voltage	2.0	V <sub>I</sub> = V <sub>IH</sub> or V <sub>IL</sub>	I <sub>O</sub> = -20 μA	1.9	2.0		1.9		1.9	V	
		4.5			4.4	4.5		4.4		4.4		
		6.0			5.9	6.0		5.9		5.9		
		4.5	I <sub>O</sub> = -4.0 mA	4.18	4.31		4.13		4.10			
		6.0		I <sub>O</sub> = -5.2 mA	5.68	5.8		5.63		5.60		
V <sub>OL</sub>	Low Level Output Voltage	2.0	V <sub>I</sub> = V <sub>IH</sub> or V <sub>IL</sub>	I <sub>O</sub> = 20 μA		0.0	0.1		0.1		0.1	V
		4.5				0.0	0.1		0.1		0.1	
		6.0				0.0	0.1		0.1		0.1	
		4.5		I <sub>O</sub> = 4.0 mA		0.17	0.26		0.33		0.40	
		6.0			I <sub>O</sub> = 5.2 mA		0.18	0.26		0.33		
I <sub>I</sub>	Input Leakage Current	6.0	V <sub>I</sub> = V <sub>CC</sub> or GND			±0.1		±1		±1	μA	
I <sub>CC</sub>	Quiescent Supply Current	6.0	V <sub>I</sub> = V <sub>CC</sub> or GND			2		20		40	μA	

AC ELECTRICAL CHARACTERISTICS ( $C_L = 50$  pF, Input  $t_r = t_f = 6$  ns)

Symbol	Parameter	Test Conditions		Value						Unit	
		V <sub>CC</sub> (V)		T <sub>A</sub> = 25 °C 54HC and 74HC			-40 to 85 °C 74HC		-55 to 125 °C 54HC		
				Min.	Typ.	Max.	Min.	Max.	Min.		Max.
t <sub>TLH</sub> t <sub>THL</sub>	Output Transition Time	2.0			30	75		95		110	ns
		4.5			8	15		19		22	
		6.0			7	13		16		19	
t <sub>PLH</sub> t <sub>PHL</sub>	Propagation Delay Time (CK-Q, $\bar{Q}$ )	2.0			50	150		190		225	ns
		4.5			16	30		38		45	
		6.0			13	26		32		38	
t <sub>PLH</sub> t <sub>PHL</sub>	Propagation Delay Time (CLR, PR-Q, $\bar{Q}$ )	2.0			50	150		190		225	ns
		4.5			16	30		38		45	
		6.0			13	26		32		38	
f <sub>MAX</sub>	Maximum Clock Frequency	2.0		6.2	17		5		4.2		MHz
		4.5		31	59		25		21		
		6.0		37	67		30		25		
t <sub>W(H)</sub> t <sub>W(L)</sub>	Minimum Pulse Width (CLOCK)	2.0			15	75		95		110	ns
		4.5			6	15		19		22	
		6.0			6	13		16		19	
t <sub>W(L)</sub>	Minimum Pulse Width (CLR, PR)	2.0			15	75		95		110	ns
		4.5			6	15		19		22	
		6.0			6	13		16		19	
t <sub>s</sub>	Minimum Set-up Time	2.0			17	75		95		110	ns
		4.5			5	15		19		22	
		6.0			4	13		16		19	
t <sub>h</sub>	Minimum Hold Time	2.0				0		0		0	ns
		4.5				0		0		0	
		6.0				0		0		0	
t <sub>REM</sub>	Minimum Removal Time (CLR, PR)	2.0			13	50		65		75	ns
		4.5			4	10		13		15	
		6.0			3	9		11		13	
C <sub>IN</sub>	Input Capacitance				5	10		10		10	pF
C <sub>PD</sub> (*)	Power Dissipation Capacitance				41						pF

(\*) C<sub>PD</sub> is defined as the value of the IC's internal equivalent capacitance which is calculated from the operating current consumption without load. (Refer to Test Circuit). Average operating current can be obtained by the following equation.  $I_{CC(opr)} = C_{PD} \cdot V_{CC} \cdot f_{IN} + I_{CC}/2$  (per Flip-flop)

# M54/M74HC109

## SWITCHING CHARACTERISTICS TEST WAVEFORM

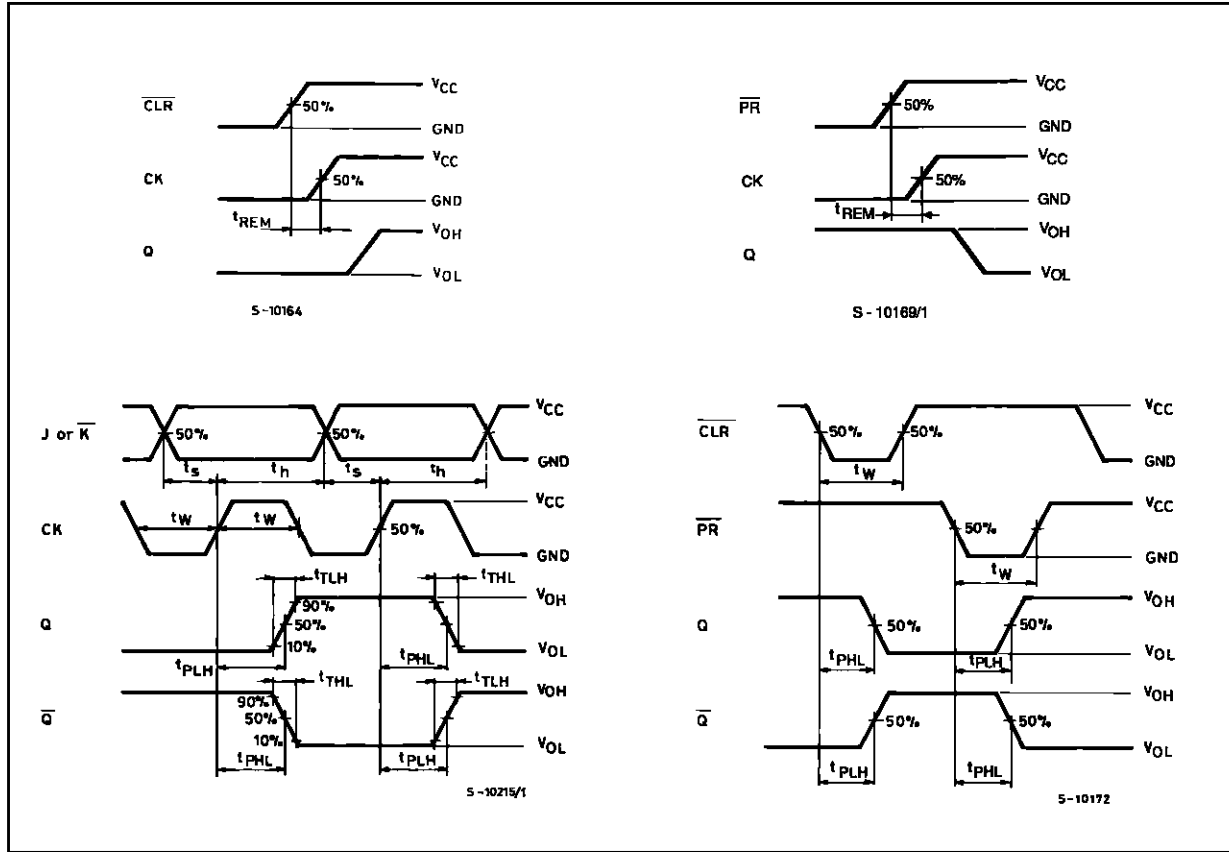

## TEST CIRCUIT $I_{CC}$ (Opr.)

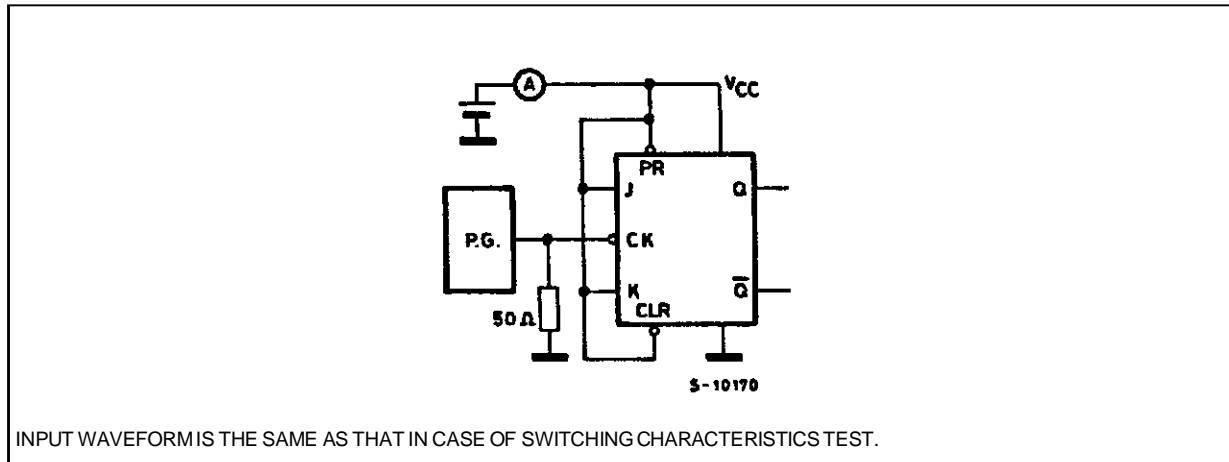

INPUT WAVEFORM IS THE SAME AS THAT IN CASE OF SWITCHING CHARACTERISTICS TEST.

**Plastic DIP16 (0.25) MECHANICAL DATA**

DIM.	mm			inch		
	MIN.	TYP.	MAX.	MIN.	TYP.	MAX.
a1	0.51			0.020		
B	0.77		1.65	0.030		0.065
b		0.5			0.020	
b1		0.25			0.010	
D			20			0.787
E		8.5			0.335	
e		2.54			0.100	
e3		17.78			0.700	
F			7.1			0.280
I			5.1			0.201
L		3.3			0.130	
Z			1.27			0.050

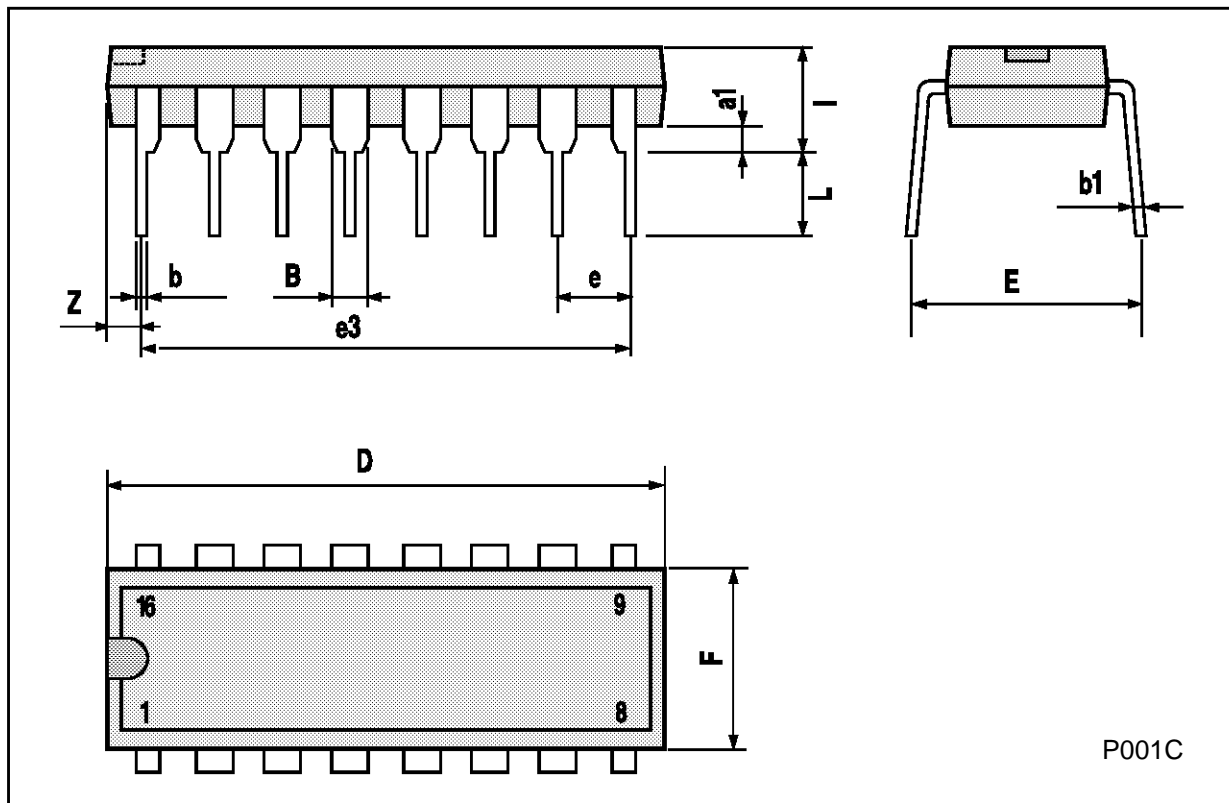

P001C

M54/M74HC109

**Ceramic DIP16/1 MECHANICAL DATA**

DIM.	mm			inch		
	MIN.	TYP.	MAX.	MIN.	TYP.	MAX.
A			20			0.787
B			7			0.276
D		3.3			0.130	
E	0.38			0.015		
e3		17.78			0.700	
F	2.29		2.79	0.090		0.110
G	0.4		0.55	0.016		0.022
H	1.17		1.52	0.046		0.060
L	0.22		0.31	0.009		0.012
M	0.51		1.27	0.020		0.050
N			10.3			0.406
P	7.8		8.05	0.307		0.317
Q			5.08			0.200

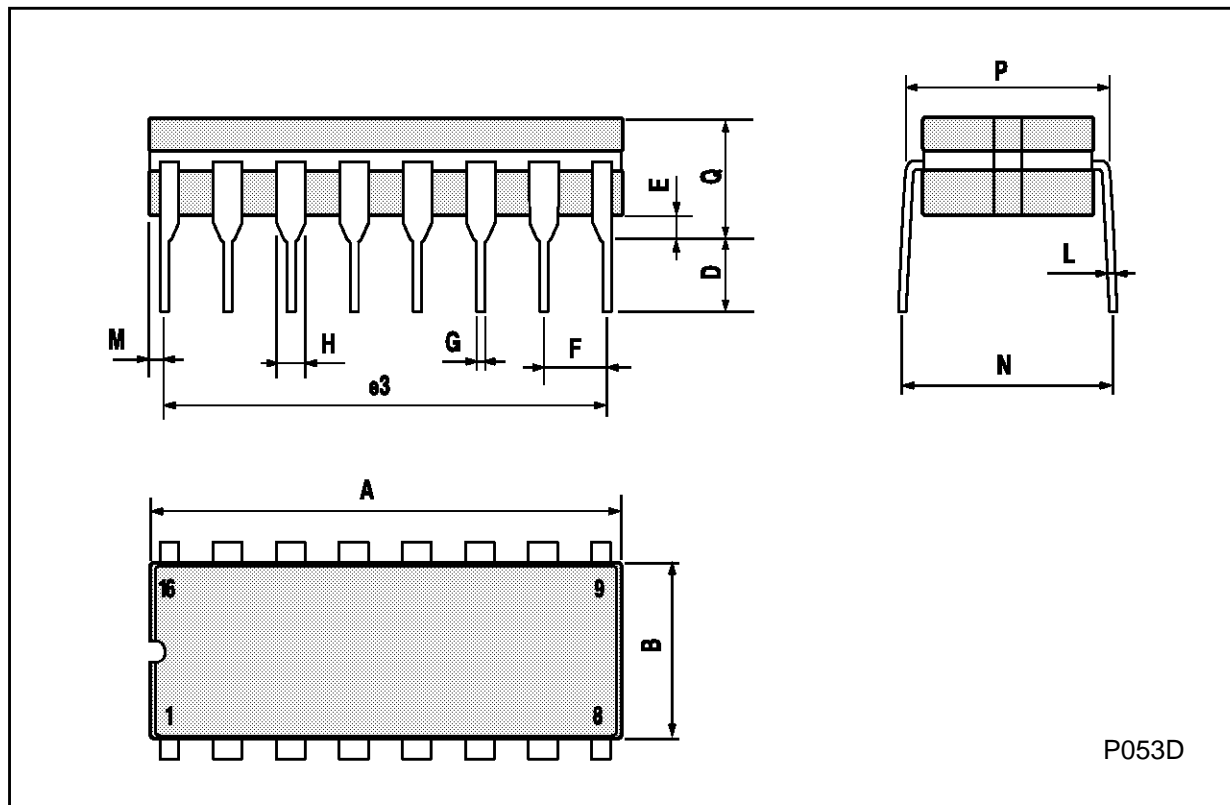

P053D

## SO16 (Narrow) MECHANICAL DATA

DIM.	mm			inch		
	MIN.	TYP.	MAX.	MIN.	TYP.	MAX.
A			1.75			0.068
a1	0.1		0.2	0.004		0.007
a2			1.65			0.064
b	0.35		0.46	0.013		0.018
b1	0.19		0.25	0.007		0.010
C		0.5			0.019	
c1	45° (typ.)					
D	9.8		10	0.385		0.393
E	5.8		6.2	0.228		0.244
e		1.27			0.050	
e3		8.89			0.350	
F	3.8		4.0	0.149		0.157
G	4.6		5.3	0.181		0.208
L	0.5		1.27	0.019		0.050
M			0.62			0.024
S	8° (max.)					

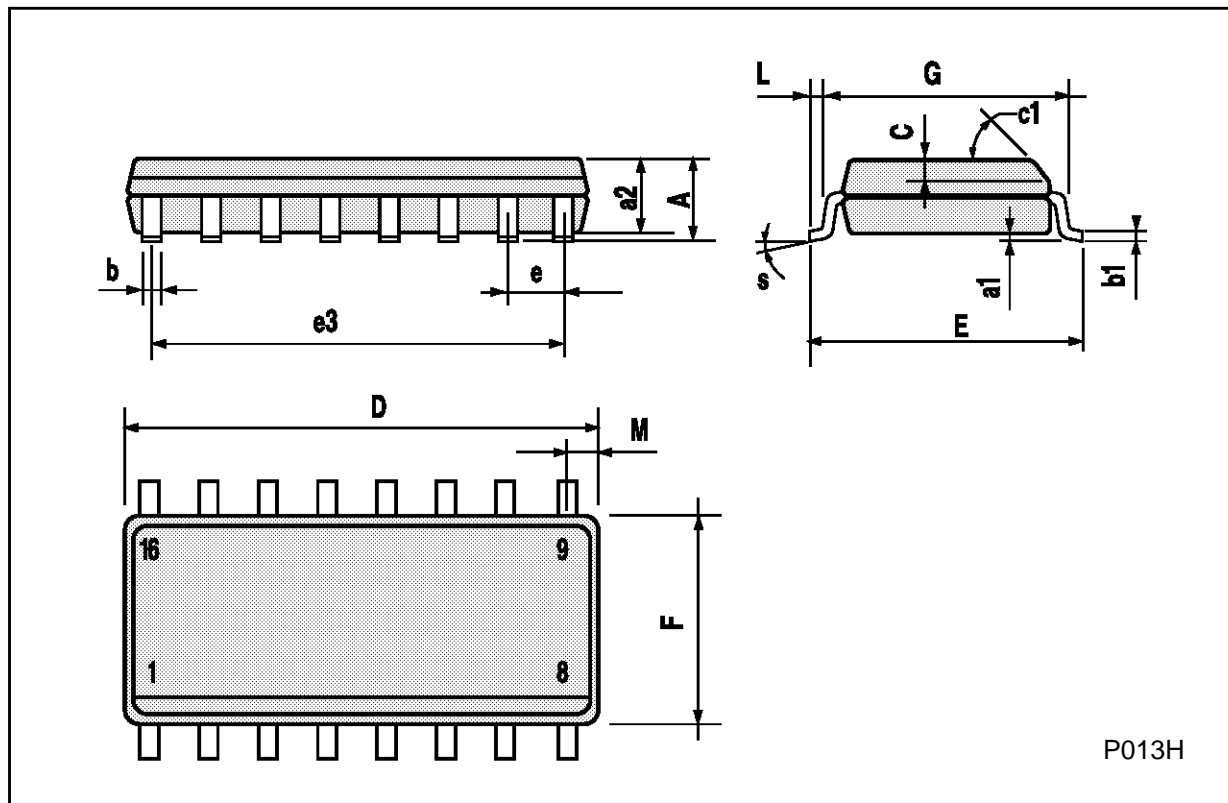

**PLCC20 MECHANICAL DATA**

DIM.	mm			inch		
	MIN.	TYP.	MAX.	MIN.	TYP.	MAX.
A	9.78		10.03	0.385		0.395
B	8.89		9.04	0.350		0.356
D	4.2		4.57	0.165		0.180
d1		2.54			0.100	
d2		0.56			0.022	
E	7.37		8.38	0.290		0.330
e		1.27			0.050	
e3		5.08			0.200	
F		0.38			0.015	
G			0.101			0.004
M		1.27			0.050	
M1		1.14			0.045	

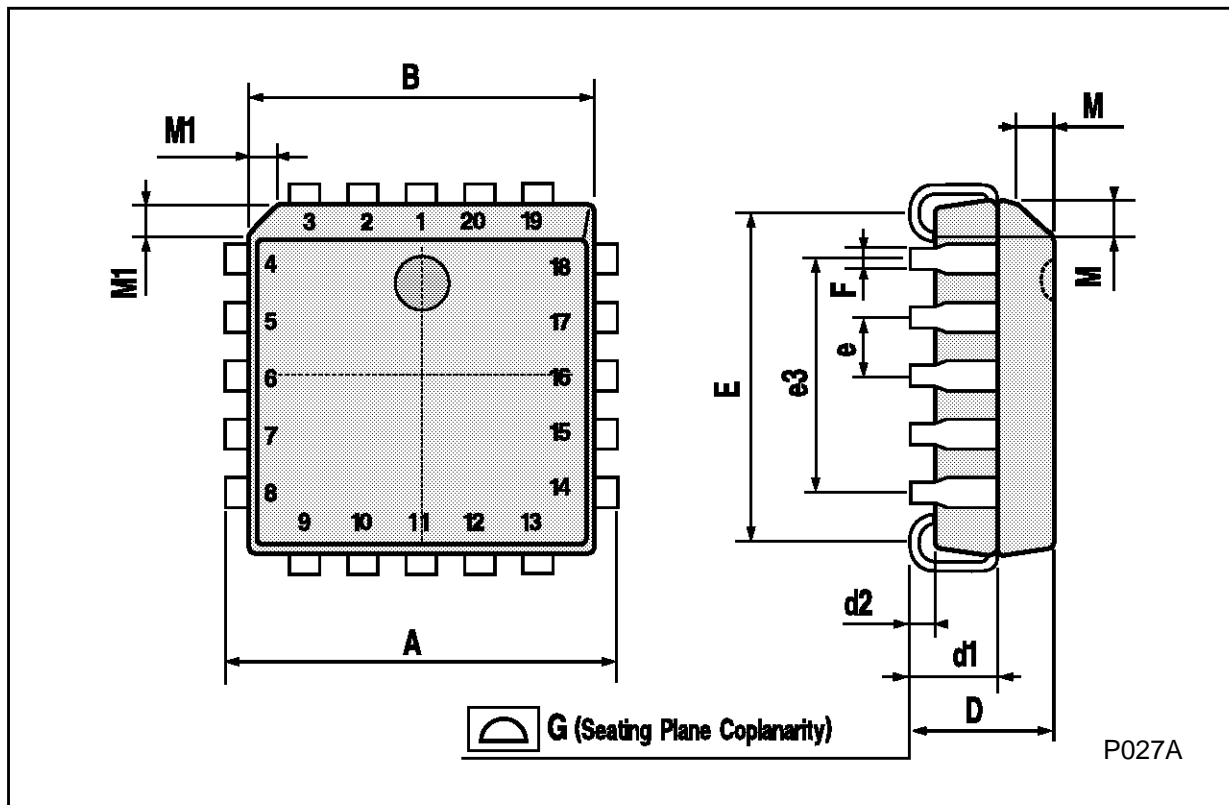

Information furnished is believed to be accurate and reliable. However, SGS-THOMSON Microelectronics assumes no responsibility for the consequences of use of such information nor for any infringement of patents or other rights of third parties which may result from its use. No license is granted by implication or otherwise under any patent or patent rights of SGS-THOMSON Microelectronics. Specifications mentioned in this publication are subject to change without notice. This publication supersedes and replaces all information previously supplied. SGS-THOMSON Microelectronics products are not authorized for use as critical components in life support devices or systems without express written approval of SGS-THOMSON Microelectronics.

© 1994 SGS-THOMSON Microelectronics - All Rights Reserved

SGS-THOMSON Microelectronics GROUP OF COMPANIES  
Australia - Brazil - France - Germany - Hong Kong - Italy - Japan - Korea - Malaysia - Malta - Morocco - The Netherlands -  
Singapore - Spain - Sweden - Switzerland - Taiwan - Thailand - United Kingdom - U.S.A