

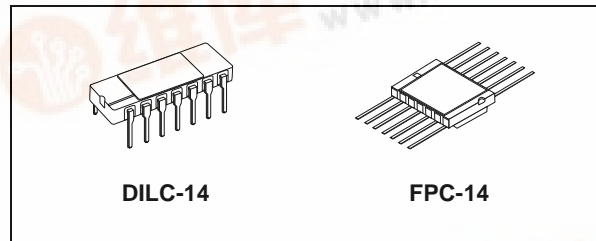

# M54HC125

## RAD-HARD QUAD BUS BUFFER (3-STATE)

- HIGH SPEED:  
 $t_{PD} = 8\text{ns}$  (TYP.) at  $V_{CC} = 6\text{V}$
- LOW POWER DISSIPATION:  
 $I_{CC} = 4\mu\text{A}$  (MAX.) at  $T_A = 25^\circ\text{C}$
- HIGH NOISE IMMUNITY:  
 $V_{NIH} = V_{NIL} = 28\% V_{CC}$  (MIN.)
- SYMMETRICAL OUTPUT IMPEDANCE:  
 $|I_{OH}| = I_{OL} = 6\text{mA}$  (MIN)
- BALANCED PROPAGATION DELAYS:  
 $t_{PLH} \cong t_{PHL}$
- WIDE OPERATING VOLTAGE RANGE:  
 $V_{CC}$  (OPR) = 2V to 6V
- PIN AND FUNCTION COMPATIBLE WITH  
 54 SERIES 125
- SPACE GRADE-1: ESA SCC QUALIFIED
- 50 krad QUALIFIED, 100 krad AVAILABLE ON  
 REQUEST
- NO SEL UNDER HIGH LET HEAVY IONS  
 IRRADIATION
- DEVICE FULLY COMPLIANT WITH  
 SCC-9401-039



### ORDER CODES

PACKAGE	FM	EM
DILC	M54HC125D	M54HC125D1
FPC	M54HC125K	M54HC125K1

The device requires the 3-STATE control input  $\overline{G}$  to be set high to place the output into the high impedance state. All inputs are equipped with protection circuits against static discharge and transient excess voltage.

### DESCRIPTION

The M54HC125 is an high speed CMOS QUAD BUFFER (3-STATE) fabricated with silicon gate C<sup>2</sup>MOS technology.

### PIN CONNECTION

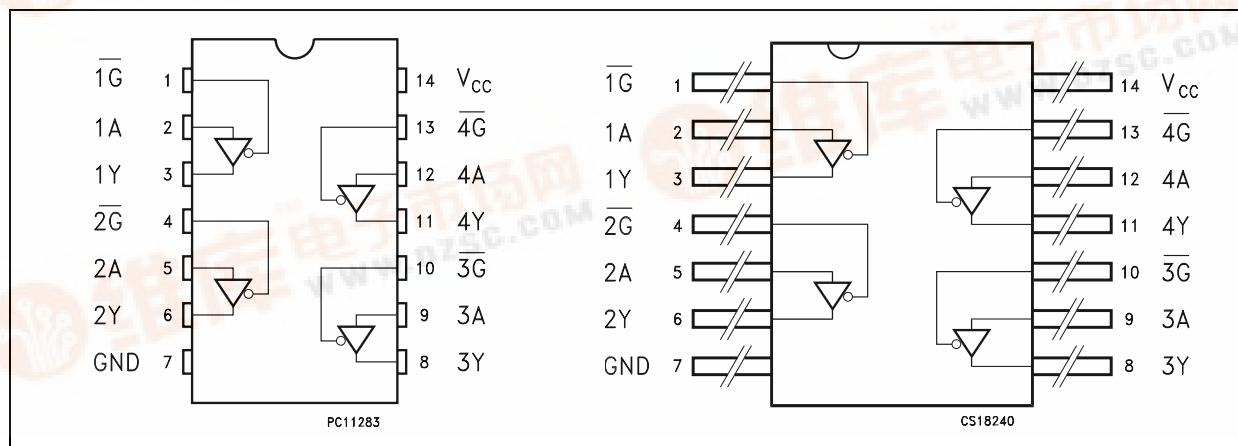

# M54HC125

## IEC LOGIC SYMBOLS

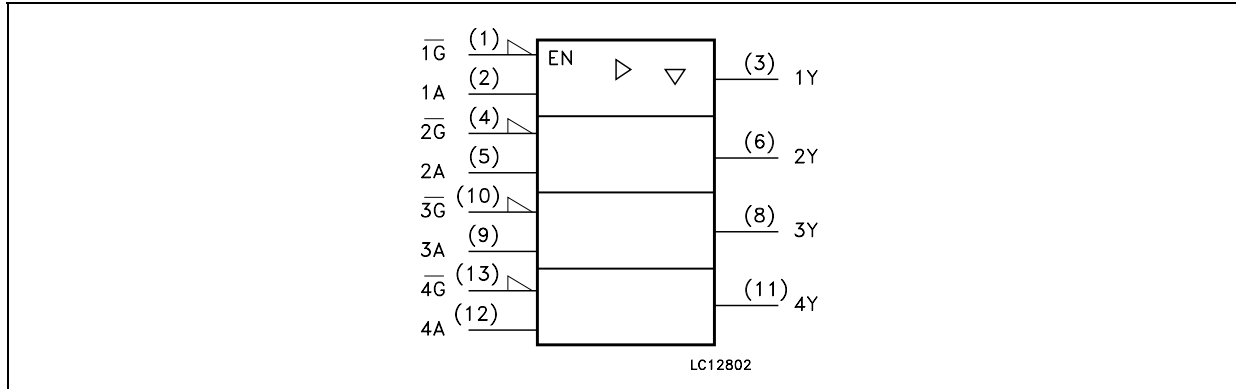

## INPUT AND OUTPUT EQUIVALENT CIRCUIT

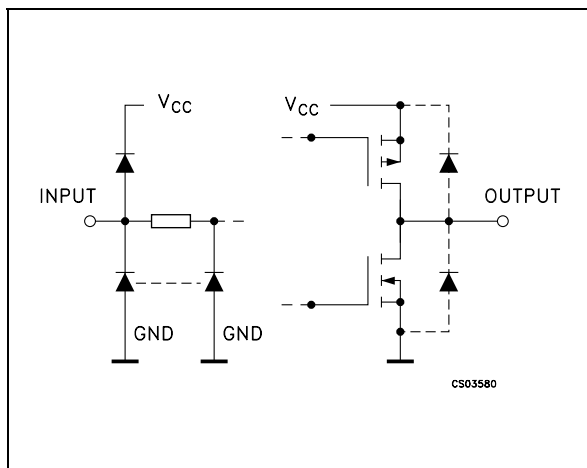

## PIN DESCRIPTION

PIN N°	SYMBOL	NAME AND FUNCTION
1, 4, 10, 13	1G TO 4G	Output Enable Input
2, 5, 9, 12	1A TO 4A	Data Inputs
3, 6, 8, 11	1Y TO 4Y	Data Outputs
7	GND	Ground (0V)
14	V <sub>CC</sub>	Positive Supply Voltage

## TRUTH TABLE

A	$\bar{G}$	Y
X	H	Z
L	L	L
H	L	H

## ABSOLUTE MAXIMUM RATINGS

Symbol	Parameter	Value	Unit
V <sub>CC</sub>	Supply Voltage	-0.5 to +7	V
V <sub>I</sub>	DC Input Voltage	-0.5 to V <sub>CC</sub> + 0.5	V
V <sub>O</sub>	DC Output Voltage	-0.5 to V <sub>CC</sub> + 0.5	V
I <sub>IK</sub>	DC Input Diode Current	± 20	mA
I <sub>OK</sub>	DC Output Diode Current	± 20	mA
I <sub>O</sub>	DC Output Current	± 35	mA
I <sub>CC</sub> or I <sub>GND</sub>	DC V <sub>CC</sub> or Ground Current	± 70	mA
P <sub>D</sub>	Power Dissipation	420	mW
T <sub>stg</sub>	Storage Temperature	-65 to +150	°C
T <sub>L</sub>	Lead Temperature (10 sec)	265	°C

Absolute Maximum Ratings are those values beyond which damage to the device may occur. Functional operation under these conditions is not implied.

## RECOMMENDED OPERATING CONDITIONS

Symbol	Parameter	Value	Unit	
$V_{CC}$	Supply Voltage	2 to 6	V	
$V_I$	Input Voltage	0 to $V_{CC}$	V	
$V_O$	Output Voltage	0 to $V_{CC}$	V	
$T_{op}$	Operating Temperature	-55 to 125	°C	
$t_r, t_f$	Input Rise and Fall Time	$V_{CC} = 2.0V$	0 to 1000	ns
		$V_{CC} = 4.5V$	0 to 500	ns
		$V_{CC} = 6.0V$	0 to 400	ns

## DC SPECIFICATIONS

Symbol	Parameter	Test Condition		Value						Unit	
		$V_{CC}$ (V)		$T_A = 25^\circ C$			-40 to 85°C		-55 to 125°C		
				Min.	Typ.	Max.	Min.	Max.	Min.		Max.
$V_{IH}$	High Level Input Voltage	2.0		1.5			1.5		1.5		V
		4.5		3.15			3.15		3.15		
		6.0		4.2			4.2		4.2		
$V_{IL}$	Low Level Input Voltage	2.0				0.5		0.5		0.5	V
		4.5				1.35		1.35		1.35	
		6.0				1.8		1.8		1.8	
$V_{OH}$	High Level Output Voltage	2.0	$I_O = -20 \mu A$	1.9	2.0		1.9		1.9		V
		4.5	$I_O = -20 \mu A$	4.4	4.5		4.4		4.4		
		6.0	$I_O = -20 \mu A$	5.9	6.0		5.9		5.9		
		4.5	$I_O = -6.0 mA$	4.18	4.31		4.13		4.10		
		6.0	$I_O = -7.8 mA$	5.68	5.8		5.63		5.60		
$V_{OL}$	Low Level Output Voltage	2.0	$I_O = 20 \mu A$		0.0	0.1		0.1		0.1	V
		4.5	$I_O = 20 \mu A$		0.0	0.1		0.1		0.1	
		6.0	$I_O = 20 \mu A$		0.0	0.1		0.1		0.1	
		4.5	$I_O = 6.0 mA$		0.17	0.26		0.33		0.40	
		6.0	$I_O = 7.8 mA$		0.18	0.26		0.33		0.40	
$I_I$	Input Leakage Current	6.0	$V_I = V_{CC}$ or GND			$\pm 0.1$		$\pm 1$		$\pm 1$	$\mu A$
$I_{OZ}$	High Impedance Output Leakage Current	6.0	$V_I = V_{IH}$ or $V_{IL}$ $V_O = V_{CC}$ or GND			$\pm 0.5$		$\pm 5$		$\pm 10$	$\mu A$
$I_{CC}$	Quiescent Supply Current	6.0	$V_I = V_{CC}$ or GND			4		40		80	$\mu A$

## M54HC125

### AC ELECTRICAL CHARACTERISTICS (Input $t_r = t_f = 6\text{ns}$ )

Symbol	Parameter	Test Condition			Value						Unit	
		$V_{CC}$ (V)	$C_L$ (pF)		$T_A = 25^\circ\text{C}$			$-40$ to $85^\circ\text{C}$		$-55$ to $125^\circ\text{C}$		
					Min.	Typ.	Max.	Min.	Max.	Min.		Max.
$t_{TLH}$ $t_{THL}$	Output Transition Time	2.0	50			20	60		75		90	ns
		4.5				6	12		15		18	
		6.0				5	10		13		15	
$t_{PLH}$ $t_{PHL}$	Propagation Delay Time	2.0	50			36	75		95		110	ns
		4.5				9	15		19		22	
		6.0				8	13		16		19	
		2.0	150			52	105		130		160	ns
		4.5				13	21		26		32	
		6.0				11	18		22		27	
$t_{PZL}$ $t_{PZH}$	High Impedance Output Enable Time	2.0	50	$R_L = 1\text{K}\Omega$		36	75		95		110	ns
		4.5				9	15		19		22	
		6.0				8	13		16		19	
		2.0	150	$R_L = 1\text{K}\Omega$		52	105		130		160	ns
		4.5				13	21		26		32	
		6.0				11	18		22		27	
$t_{PLZ}$ $t_{PHZ}$	High Impedance Output Disable Time	2.0	50	$R_L = 1\text{K}\Omega$		48	80		100		120	ns
		4.5				12	16		20		24	
		6.0				10	14		17		20	

### CAPACITIVE CHARACTERISTICS

Symbol	Parameter	Test Condition			Value						Unit	
		$V_{CC}$ (V)			$T_A = 25^\circ\text{C}$			$-40$ to $85^\circ\text{C}$		$-55$ to $125^\circ\text{C}$		
					Min.	Typ.	Max.	Min.	Max.	Min.		Max.
$C_{IN}$	Input Capacitance	5.0				5	10		10		10	pF
$C_{PD}$	Power Dissipation Capacitance (note 1)	5.0				35						pF

1)  $C_{PD}$  is defined as the value of the IC's internal equivalent capacitance which is calculated from the operating current consumption without load. (Refer to Test Circuit). Average operating current can be obtained by the following equation.  $I_{CC(OPR)} = C_{PD} \times V_{CC} \times f_{IN} + I_{CC}/4$  (per buffer)

TEST CIRCUIT

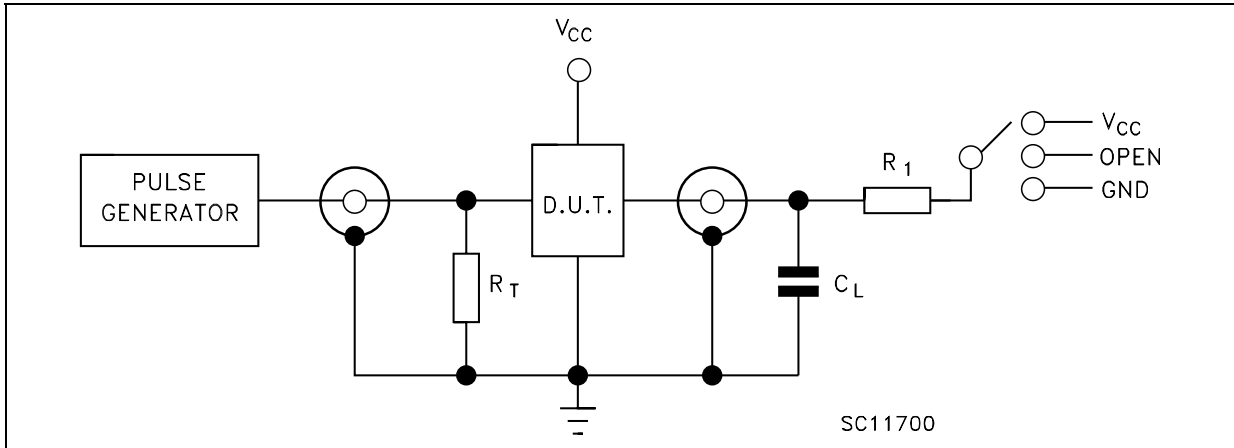

TEST	SWITCH
$t_{PLH}$ , $t_{PHL}$	Open
$t_{PZL}$ , $t_{PLZ}$	$V_{CC}$
$t_{PZH}$ , $t_{PHZ}$	GND

$C_L$  = 50pF/150pF or equivalent (includes jig and probe capacitance)  
 $R_T$  = 1K $\Omega$  or equivalent  
 $R_T$  =  $Z_{OUT}$  of pulse generator (typically 50 $\Omega$ )

WAVEFORM 1: PROPAGATION DELAY TIMES (f=1MHz; 50% duty cycle)

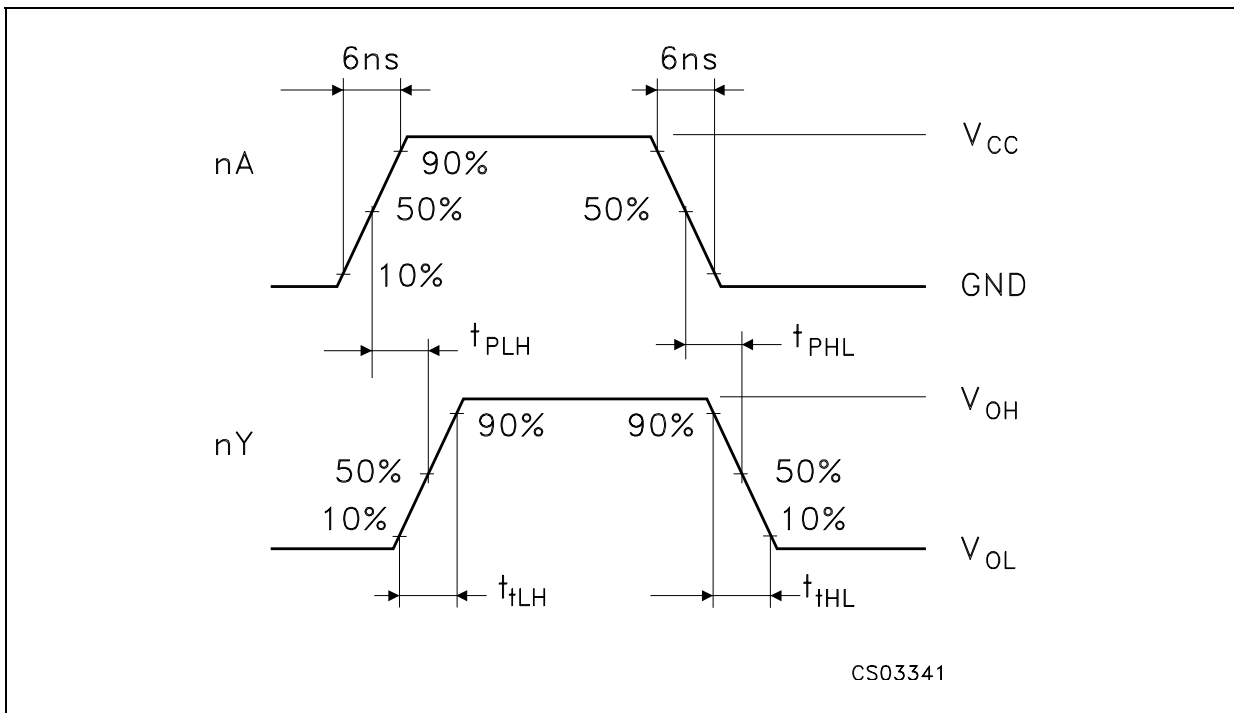



## DILC-14 MECHANICAL DATA

DIM.	mm.			inch		
	MIN.	TYP.	MAX.	MIN.	TYP.	MAX.
A	2.1		22.54	0.083		0.100
a1	3.00		3.70	0.118		0.146
a2	0.63	0.88	1.14	0.025	0.035	0.045
B	1.82	2.03	2.39	0.072	0.080	0.094
b	0.40	0.45	0.50	0.016	0.018	0.020
b1	0.20	0.254	0.30	0.008	0.010	0.012
D	18.79	19.00	19.20	0.740	0.748	0.756
e	7.36	7.62	7.87	0.290	0.300	0.310
e1		2.54			0.100	
e2	15.11	15.24	15.37	0.595	0.600	0.605
e3	7.62	7.87	8.12	0.300	0.310	0.320
F	7.11		7.75	0.280		0.305
l			3.70			0.146
K	10.90		12.1	0.429		0.476
L	1.14	1.27	1.5	0.045	0.050	0.059

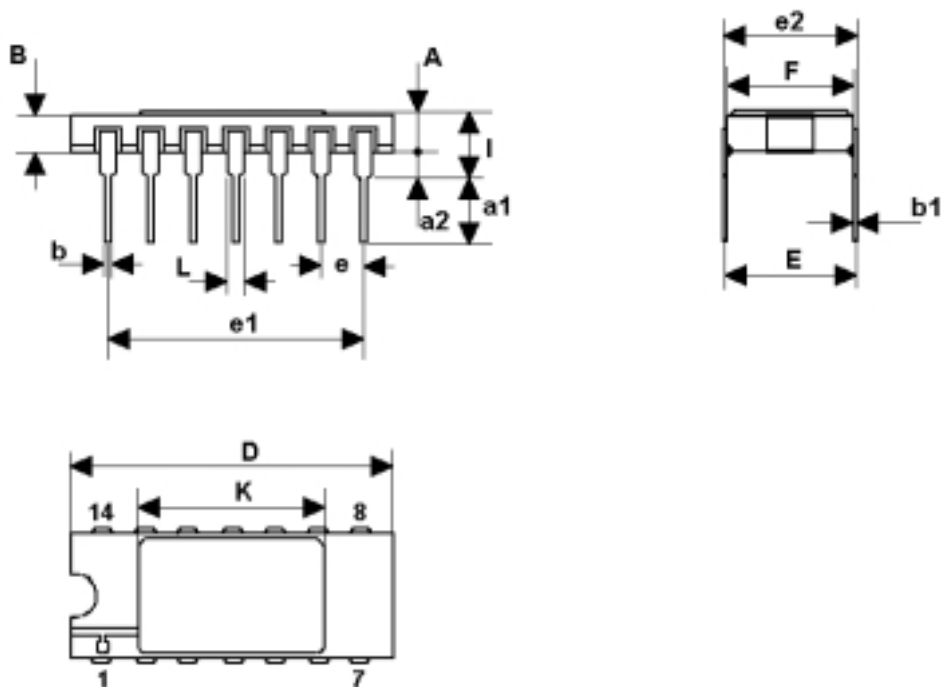

0016173H

**FPC-14 MECHANICAL DATA**

DIM.	mm.			inch		
	MIN.	TYP	MAX.	MIN.	TYP.	MAX.
A	6.75	6.91	7.06	0.266	0.272	0.278
B	9.76	9.95	10.14	0.384	0.392	0.399
C	1.49		1.95	0.059		0.077
D	0.10	0.127	0.15	0.004	0.005	0.006
E	7.50	7.62	7.75	0.295	0.300	0.305
F		1.27			0.050	
G	0.38	0.43	0.48	0.015	0.017	0.019
H		6.0			0.236	
L	18.75		22.0	0.738		0.866
M		0.38			0.015	
N		4.31			0.170	

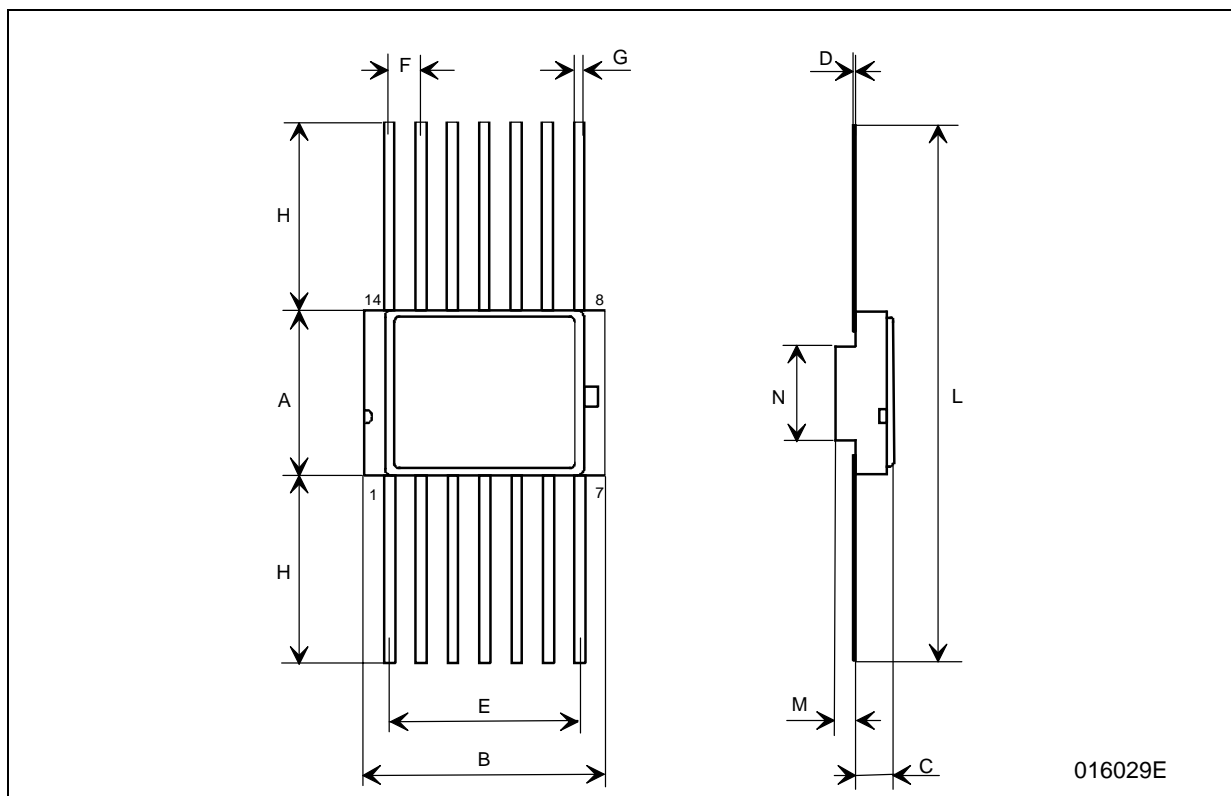

Information furnished is believed to be accurate and reliable. However, STMicroelectronics assumes no responsibility for the consequences of use of such information nor for any infringement of patents or other rights of third parties which may result from its use. No license is granted by implication or otherwise under any patent or patent rights of STMicroelectronics. Specifications mentioned in this publication are subject to change without notice. This publication supersedes and replaces all information previously supplied. STMicroelectronics products are not authorized for use as critical components in life support devices or systems without express written approval of STMicroelectronics.

The ST logo is a registered trademark of STMicroelectronics  
All other names are the property of their respective owners

© 2004 STMicroelectronics - All Rights Reserved  
STMicroelectronics GROUP OF COMPANIES

Australia - Belgium - Brazil - Canada - China - Czech Republic - Finland - France - Germany - Hong Kong - India - Israel - Italy - Japan -  
Malaysia - Malta - Morocco - Singapore - Spain - Sweden - Switzerland - United Kingdom - United States.  
<http://www.st.com>