

MITSUBISHI <CONTROL / DRIVER IC>

# M56745FP

SPINDLE MOTOR DRIVER

## DESCRIPTION

The M56745FP is a semiconductor integrated circuit designed for a single chip controller for CD-ROM spindle motor.

M56745FP has a both (forward and reverse) motor rotation control by the motor speed control terminal.

Also, this device includes a bias circuit for Hall Sensor, a current limit circuit and a thermal shut down function.

## FEATURES

- The supply voltage with wide range. (4.5V to 13.2V)
- High motor drive current (1.0A).
- Motor current control for the both motor rotation is possible.

## APPLICATION

CD-ROM

## PIN CONFIGURATION (TOP VIEW)

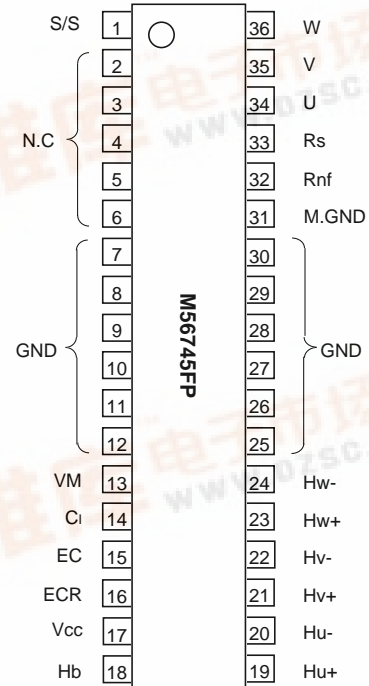

Outline 36P2R-D

N.C.: No connection

## BLOCK DIAGRAM

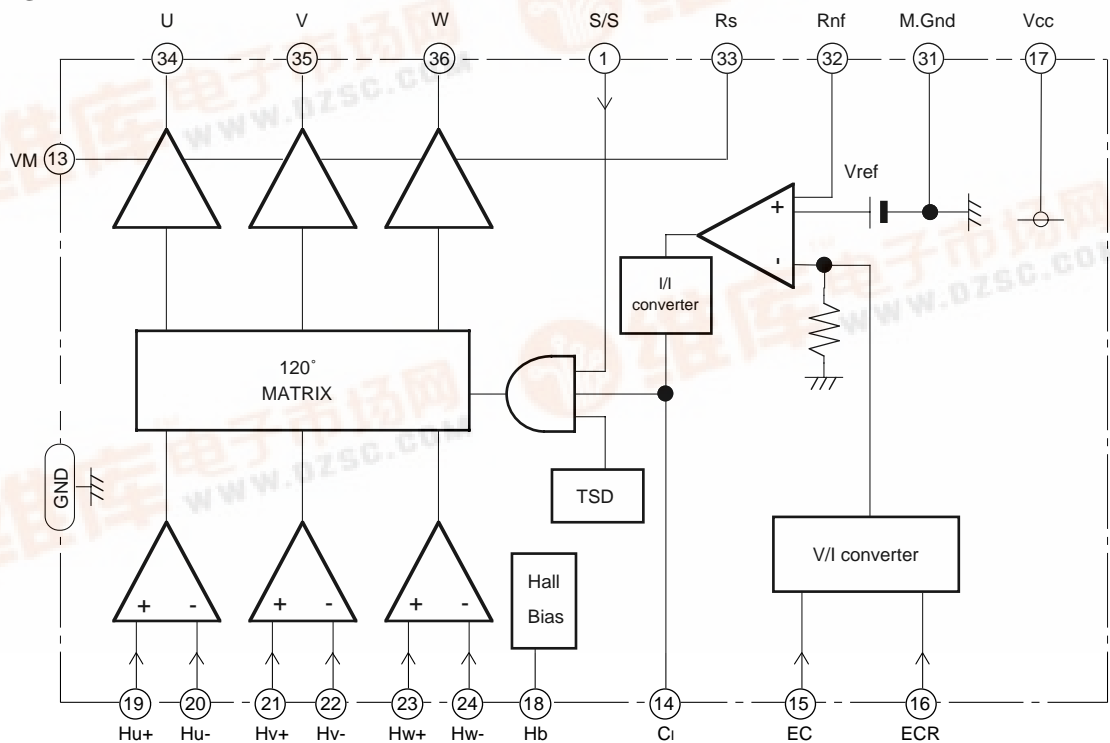

**PIN FUNCTION**

Pin No.	Symbol	Function
①	S/S	Start / Stop
②	N.C	
③	N.C	
④	N.C	
⑤	N.C	
⑥	N.C	
⑦ to ⑫	GND	GND
⑬	VM	Motor supply voltage
⑭	Ci	Phase Compensation
⑮	EC	Motor speed control
⑯	ECR	The reference voltage for EC.
⑰	Vcc	5V supply voltage.
⑱	Hb	Bias for Hall Sensor
⑲	Hu+	Hu+ Sensor amp. input
⑳	Hu-	Hu- Sensor amp. input
㉑	Hv+	Hv+ Sensor amp. input
㉒	Hv-	Hv- Sensor amp. input
㉓	Hw+	Hw+ Sensor amp. input
㉔	Hw-	Hw- Sensor amp. input
㉕ to ㉚	GND	GND
㉛	M.GND	Motor GND.
㉜	Rnf	Current feedback amp. input
㉝	Rs	Motor current sense.
㉞	U	Motor drive output U
㉟	V	Motor drive output V
㊱	W	Motor drive output W

**ABSOLUTE MAXIMUM RATINGS (Ta=25°C)**

Symbol	Parameter	Conditions	Ratings	Units
VM	Motor supply voltage	⑬ pin maximum input voltage	14	V
Vcc	5V supply voltage	⑰ pin maximum input voltage	7.0	V
Io	Output current		1.0	A
VH(c)	Sensor amp. Differential input range	⑲ to ㉔ pins	4.5	V
Pt	Power dissipation	Free Air	1.2	W
Kθ	Thermal derating	Free Air	9.6	mW/°C
Tj	Junction temperature		150	°C
Topr	Operating temperature		-20 – +75	°C
Tstg	Storage temperature		-40 – +125	°C

**RECOMMENDED OPERATING CONDITIONS**

Symbol	Parameter	Limits			Units
		Min.	Typ.	Max.	
Vcc	5V Power supply	4.5	5.0	5.5	V
VM	Motor Power supply	10.8	12.0	13.2	V
Io	Output drive current	—	—	700	mA

**ELECTRICAL CHARACTERISTICS** (Ta=25°C, VM=12V, Vcc=5V, unless otherwise noted)

Symbol	Parameter	Conditions	Limits			Unit
			Min.	Typ.	Max.	
Icc1	Sleep Mode Supply current-1	⑬ pin Input Current (EC=ECR=2.5V), ⑭ pin GND.	—	0	100	μA
Icc2	Sleep Mode Supply current-2	⑰ pin Input Current (EC=ECR=2.5V), ⑭ pin GND.	—	3.8	6.0	mA
Vsat	Saturation voltage	Top and Bottom saturation voltage. Load current 500mA.	—	1.5	2.4	V
ECdead-	Control voltage dead zone	EC < ECR	-50	-25	-5	mV
ECdead+		EC > ECR	+5	+25	+25	
ECR	Reference voltage input range	⑯ pin Input voltage range.	1.9	2.1	2.3	V
EC	Control voltage input range	⑮ pin Input voltage range.	1.0	—	4.0	V
Gio	Current gain	Rs=0.47Ω	0.55	0.65	0.75	A/V
Von	Motor start voltage	① pin input voltage when makes the motor start up.	3.5	—	—	V
Voff	Motor stop voltage	① pin input voltage when makes the motor stop.	—	—	1.5	V
VH (IN)	Sensor amp. common mode input range	⑲ to ⑳ pins input range.	1.2	—	4.5	V
VH (INH)	Sensor amp. input signal revel	⑲ to ⑳ pins input signal revel.	50	—	—	mV
Vlim	Current limit	Rs=0.47Ω	0.45	0.50	0.55	A
VHb	Hall bias terminal output voltage	Load current (IHb) 10mA.	1.0	1.2	1.5	V
IHb	Hall bias terminal sink current		—	—	10	mA

**ELECTRICAL CHARACTERISTICS** (Vcc=5V, VM=12V, Ta=25°C, Unless otherwise noted)

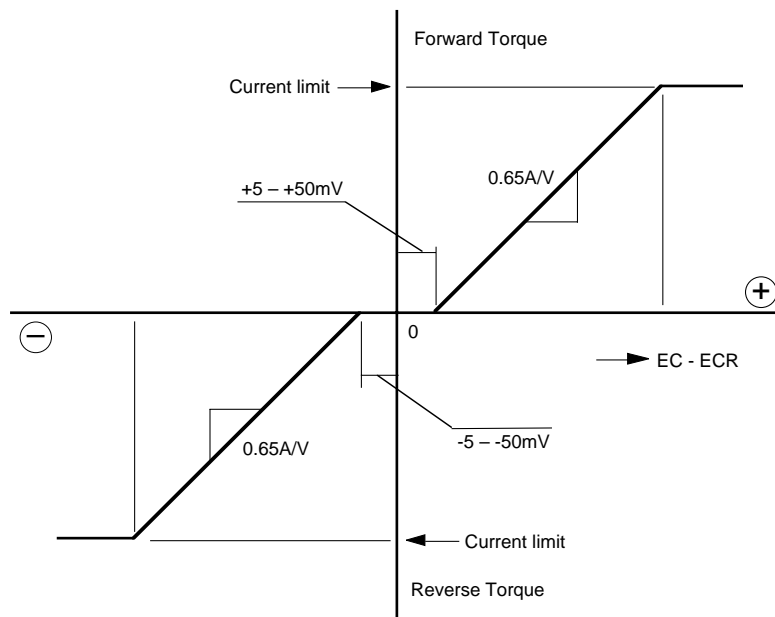

The relationship between the EC (control voltage), ECR (reference voltage) and the torque is as shown in Figure 1. The current gain is 0.65A/V in the both torques and a dead zone is ±5mV to ±50mV.

Figure 1. The characteristics of the control voltage and motor current (Torque).

**BASICALLY CHARACTERISTICS**

Output saturation voltage and Load current characteristics.  
 (Condition  $V_m=12V$ ,  $V_{cc}=5V$ )

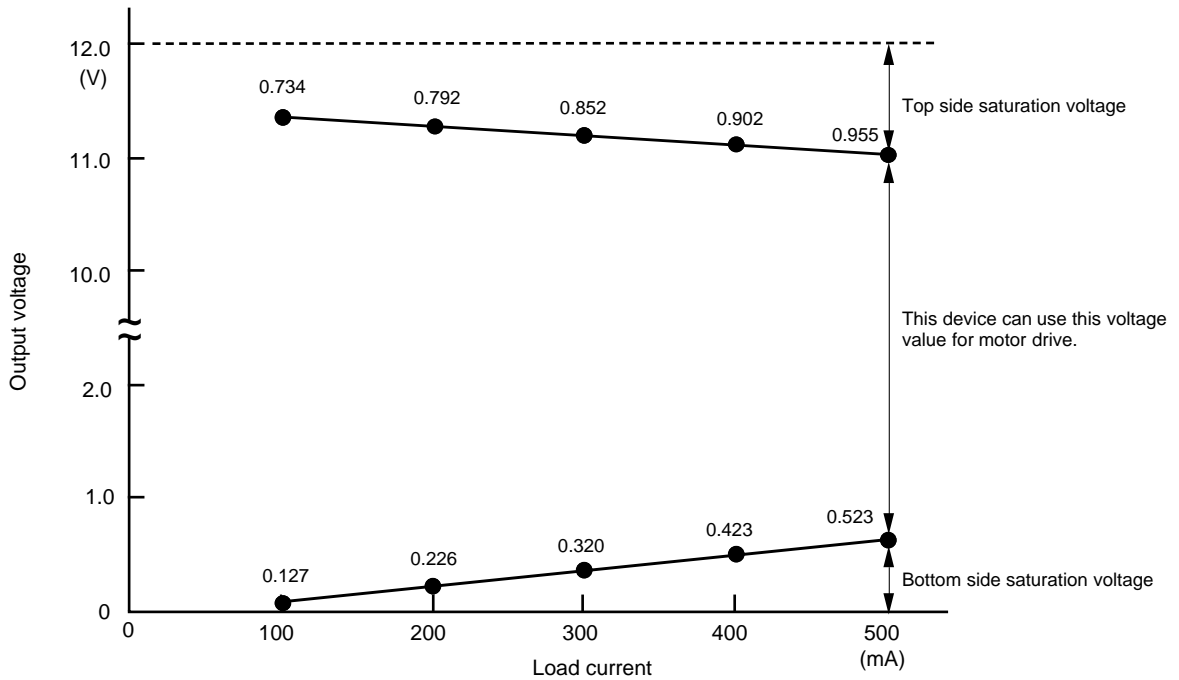

**THERMAL DERATING**

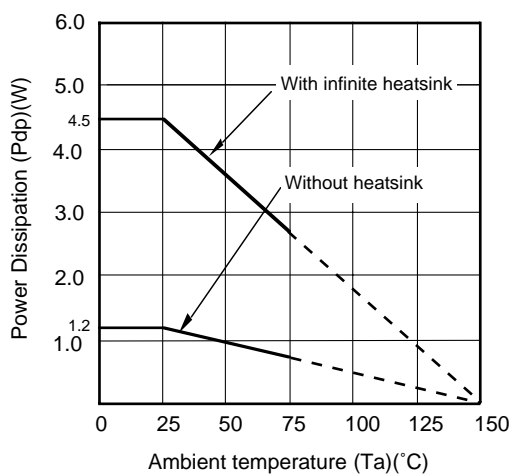

# M56745FP

## SPINDLE MOTOR DRIVER

### APPLICATION CIRCUIT

