

M56788FP

5 CHANNEL ACTUATOR DRIVER

DESCRIPTION

The M56788FP is a semiconductor integrated circuit in order 5ch actuator.

FEATURES

- Low saturation voltage.
- 3.3V DSP available.
- There are two motor power supplies.
Vm1 CH1,2 motor power supply-1
Vm2 CH3,4,5 motor power supply-2
- Built-in OP amp. for Regulator.
(It enables a Regulator which consists of external PNP Tr.s and resistors.)
- Flexible Input amp. setting.(It enables PWM control.)
- Low cross-over distortion.(4.5V-13.2V)
- Wide supply voltage range.(4.5V-13.2V)
- Built-in Thermal Shut Down circuit.
- Built-in Mute circuit.(two systems)
MUTE1:CH1-4, MUTE2:CH5

APPLICATION

MD, CD-audio, CD-ROM, VCD,DVD etc.

PIN CONFIGURATION (TOP VIEW)

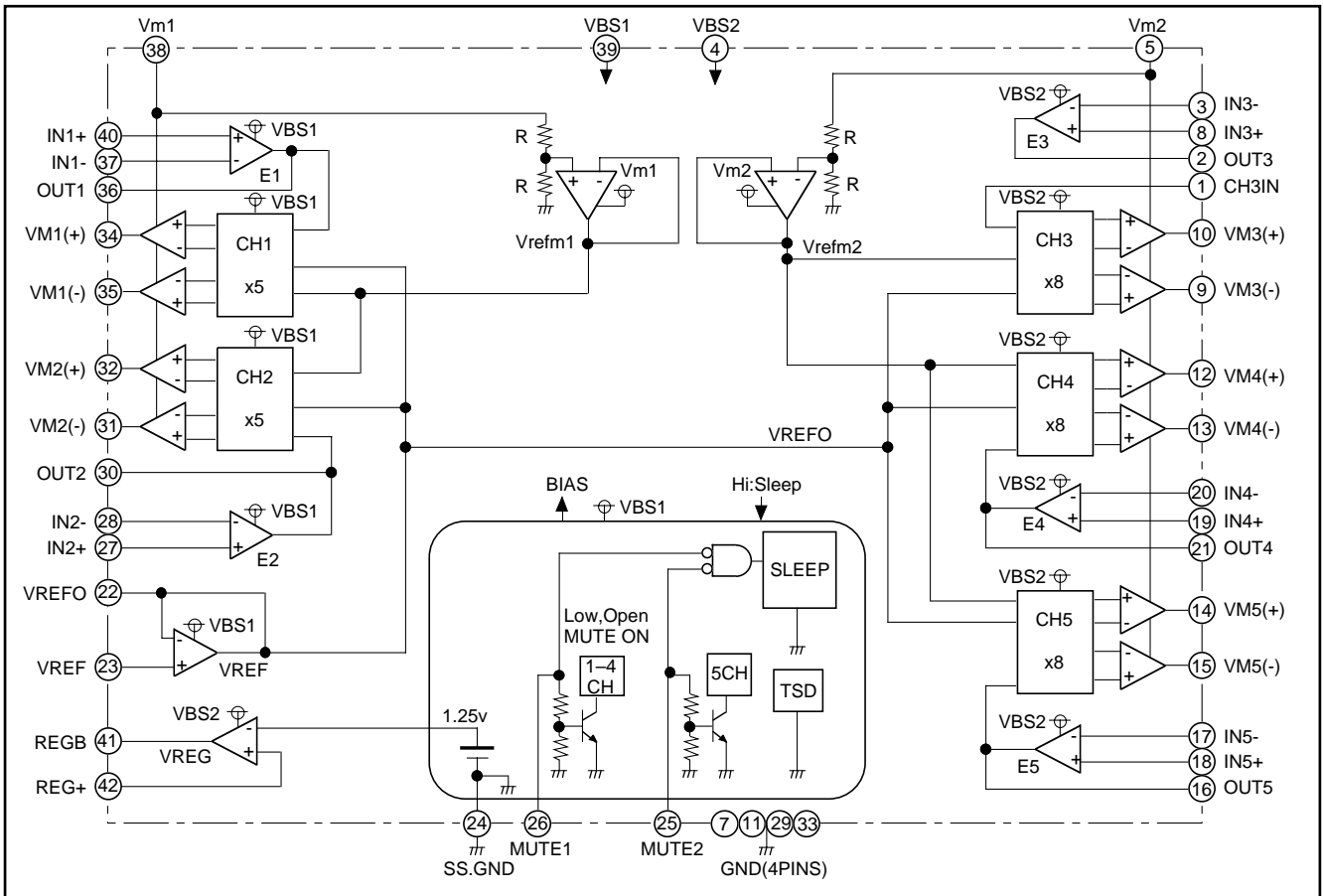
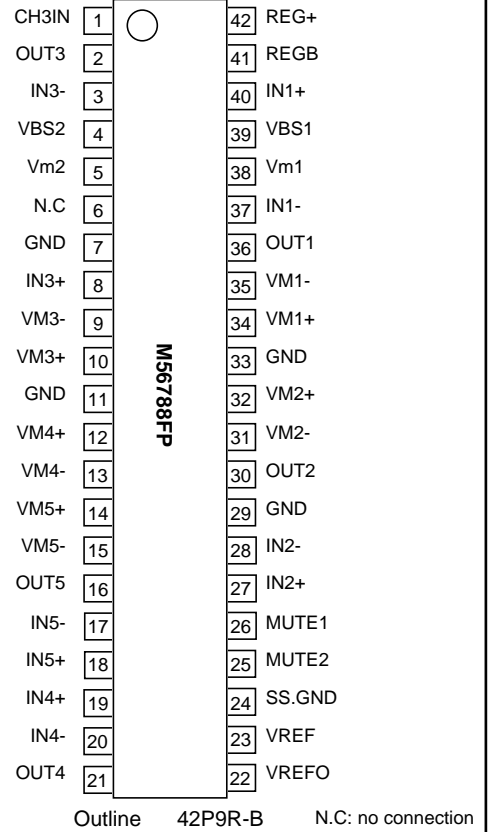

PIN FUNCTION

Terminal	Symbol	Terminal function	Terminal	Symbol	Terminal function
①	CH3IN	CH3 non-inverted input	②②	VREF0	Reference voltage output
②	OUT3	E3 amplifier output	②③	VREF	Reference voltage input
③	IN3-	E3 amplifier inverted input	②④	SS.GND	Small signal GND
④	VBS2	Bootstrap power supply	②⑤	MUTE2	CH5 mute
⑤	Vm2	Motor power supply	②⑥	MUTE1	CH1-4 mute
⑥	N.C	N.C	②⑦	IN2+	E2 amplifier non-inverted input
⑦,⑪	GND	Motor GND	②⑧	IN2-	E2 amplifier inverted input
⑧	IN3+	E3 amplifier non-inverted input	②⑨,③③	GND	Motor GND
⑨	VM3(-)	CH3 inverted output	③⑩	OUT2	E2 amplifier output
⑩	VM3(+)	CH3 non-inverted output	③⑪	VM2(-)	CH2 inverted output
⑫	VM4(+)	CH4 non-inverted output	③⑫	VM2(+)	CH2 non-inverted output
⑬	VM4(-)	CH4 inverted output	③⑬	VM1(+)	CH1 non-inverted output
⑭	VM5(+)	CH5 non-inverted output	③⑭	VM1(-)	CH1 inverted output
⑮	VM5(-)	CH5 inverted output	③⑮	OUT1	E1 amplifier output
⑯	OUT5	E5 amplifier output	③⑰	IN1-	E1 amplifier inverted input
⑰	IN5-	E5 amplifier inverted input	③⑱	Vm1	Motor power supply
⑱	IN5+	E5 amplifier non-inverted input	③⑲	VBS1	Bootstrap power supply
⑳	IN4+	E4 amplifier non-inverted input	④⑰	IN1+	E1 amplifier non-inverted input
㉑	IN4-	E4 amplifier inverted input	④⑱	REGB	Regulator PNP base connect
㉒	OUT4	E4 amplifier output	④⑲	REG+	Regulator voltage setting resistor

ABSOLUTE MAXIMUM RATING (Ta=25°C)

Symbol	Parameter	Conditions	Rating	Units
VBS	Bootstrap power supply	VBS power supply	15	V
Vm	Motor power supply	Vm power supply	15	V
Io	Output Current		500	mA
Vin	Maximum input voltage of terminals	23, 25, 26, 27, 28, 37, 40PIN	0-VBS1	V
		1, 3, 8, 17, 18, 19, 20, 42PIN	0-VBS2	V
Pt	Power dissipation	Free Air	1.2	W
Kq	Thermal derating	Free Air	9.6	mW/°C
Tj	Junction temperature		150	°C
Topr	Operating temperature		-20~+75	°C
Tstg	Storage temperature		-40~+150	°C

RECOMMENDED OPERATING CONDITIONS

Symbol	Parameter	Limits			Units
		Min	Typ	Max	
Vm1,Vm2	Motor power supply		5.0		V
VBS1,VBS2	Bootstrap power supply		Vm*+1.0		V

ELECTRICAL CHARACTERISTICS (Ta=25°C, VBS=Vm=5V unless otherwise noted.)

Symbol	Parameter	Conditions	Limits			Units
			Min	Typ	Max	
Icc1	Supply current-1	VBS1,VBS2,Vm1,Vm2 current	—	35	50	mA
Icc2	Supply current-2	VBS1,VBS2,Vm1,Vm2 current at Sleep Mode (MUTE 1=MUTE 2=0V).	—	1.3	2.2	mA
Vsat1	CH1-5 Saturation voltage	Top and Bottom saturation voltage. Load current 0.5A and no bootstrap.	—	1.35	1.9	V
Voff1	CH1 output offset voltage	VREFO=OUT1=1.5V	-41	—	41	mV
Voff2	CH2 output offset voltage	VREFO=OUT2=1.5V	-41	—	41	mV
Voff3	CH3 output offset voltage	VREFO=CH3IN=1.5V	-47	—	47	mV
Voff4	CH4 output offset voltage	VREFO=OUT4=1.5V	-47	—	47	mV
Voff5	CH5 output offset voltage	VREFO=OUT5=1.5V	-47	—	47	mV
Gain1	CH1 Voltage Gain between input and output	$\frac{\{VM1(+)-VM1(-)\}}{(OUT1-VREFO)}$	4.5	5	5.5	V/V
Gain2	CH2 Voltage Gain between input and output	$\frac{\{VM2(+)-VM2(-)\}}{(OUT2-VREFO)}$	4.5	5	5.5	V/V
Gain3	CH3 Voltage Gain between input and output	$\frac{\{VM3(+)-VM3(-)\}}{(CH3IN-VREFO)}$	7.2	8	8.8	V/V
Gain4	CH4 Voltage Gain between input and output	$\frac{\{VM4(+)-VM4(-)\}}{(OUT4-VREFO)}$	7.2	8	8.8	V/V
Gain5	CH5 Voltage Gain between input and output	$\frac{\{VM5(+)-VM5(-)\}}{(OUT5-VREFO)}$	7.2	8	8.8	V/V
VinE	E1,2,3,4,5 amplifier input voltage range	E1,E2 amp	0.5	—	VBS1-2.0	V
		E3,E4,E5 amp	0.5	—	VBS2-2.0	V
VoutE	E1,2,3,4,5 amplifier output voltage range	E1,E2 amp(no load)	0.5	—	VBS1-0.5	V
		E3,E4,E5 amp(no load)	0.5	—	VBS2-0.5	V
VofE	E1,2,3,4,5 amplifier offset voltage	Vin = 1.5V(at buffer)	-10	—	+10	mV
IinE	E1,2,3,4,5 amplifier input current	IN+=IN-=1.5V	-1.0	-0.05	0	μA
Reg-out	Regulator output voltage range	At VBS=7.5V, Regulator voltage setting resistor 10K/30K, connects external PNP.	4.8	5.0	5.2	V
VinVREF	VREF amplifier input voltage range		1.0	—	VBS1-2.0	V
VofVREF	VREF amplifier offset voltage	Vin=1.5V ±2mA load	-10	—	+10	mV
IinVREF	VREF amplifier input current	VREF=1.5V	-1.0	-0.05	0	μA
Vmute-on	Mute-on voltage	Mute-on	—	—	0.8	V
Vmute-off	Mute-off voltage	Mute-off	2.0	—	—	V
Imute	Mute terminal input current	Mute terminal input current(at 5V input voltage)	—	170	250	μA

MUTE Function

M56788FP has 2 MUTE terminals and the functions are as follows.

MUTE 1 ⑳ pin	MUTE 2 ㉑ pin	Power and Control Amp. circuits of CH1 to CH4.	Power and Control Amp. circuits of CH5.	VREF Amp.	VREG Amp.
High	High	ENABLE	ENABLE	ENABLE	ENABLE
Low/Open	High	DISABLE	ENABLE	ENABLE	ENABLE
High	Low/Open	ENABLE	DISABLE	ENABLE	ENABLE
Low/Open	Low/Open	DISABLE	DISABLE	DISABLE	ENABLE

When both MUTE1 inputs and MUTE 2 inputs are low voltage or open, the IC is in Sleep Mode.

INPUT and OUTPUT CHARACTERISTICS of EACH CHANNELS

CH1,2

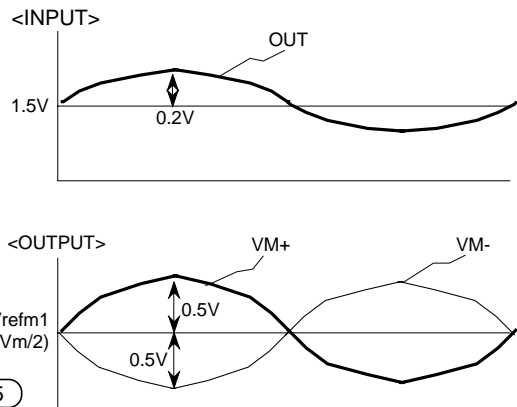
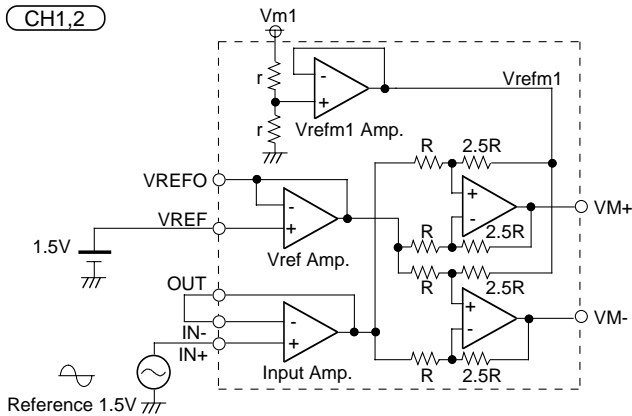

CH3

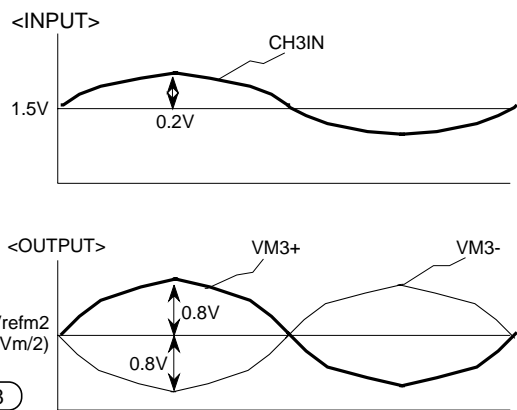
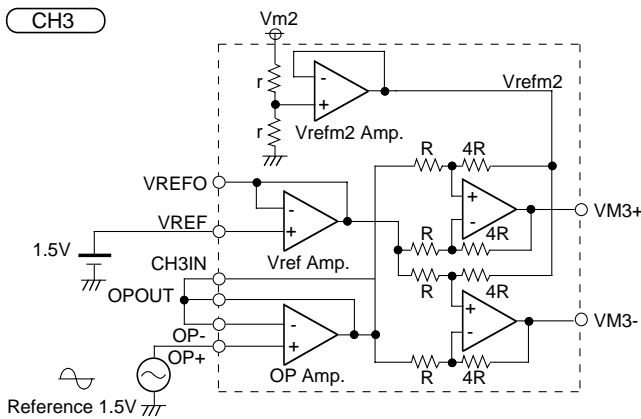

CH4,5

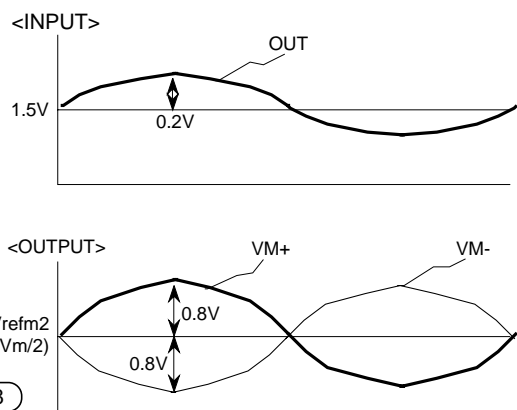
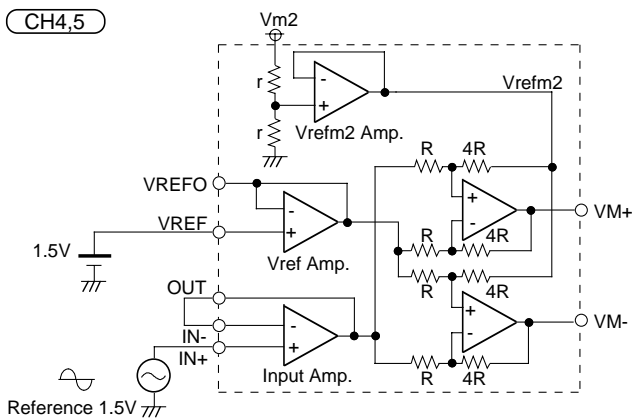

I/O terminal Equivalent circuit

(1)E1, E2 input amplifier
I/O terminal equivalent circuit

(IN1+, IN1-, OUT1, IN2+, IN2-, OUT2)

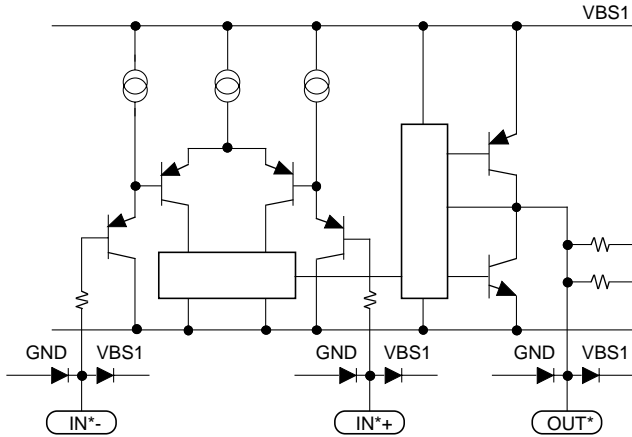

(2)E3, E4, E5 input amplifier
I/O terminal equivalent circuit

(IN3+, IN3-, OUT3, IN4+, IN4-, OUT4, IN5+, IN5-, OUT5)

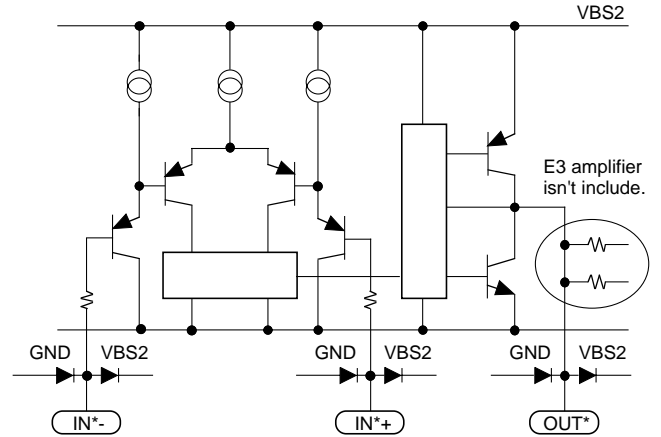

(3)VREF amplifier I/O terminal equivalent circuit

(VREF, VREFO)

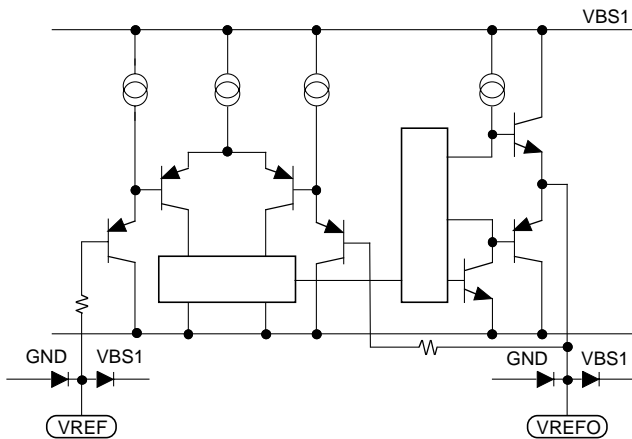

(3)VREG amplifier I/O terminal equivalent circuit

(REG+, REGB)

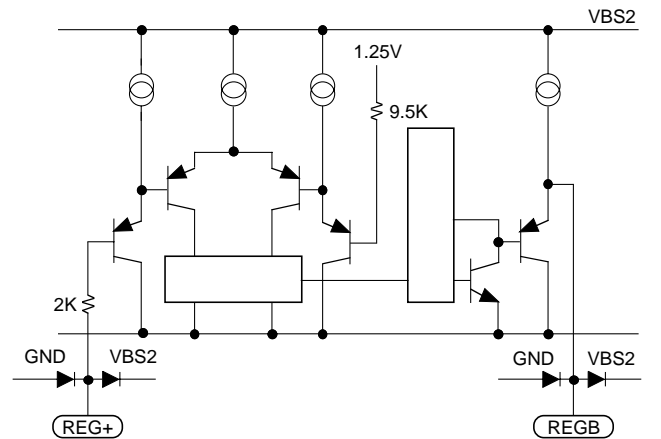

(5)CH3IN input terminal equivalent circuit
Please refer to the application circuits.
(It shows the circuitry of the IC.)

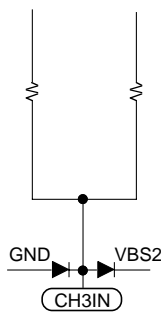

(3)MUTE equivalent circuit

(MUTE1, MUTE2)

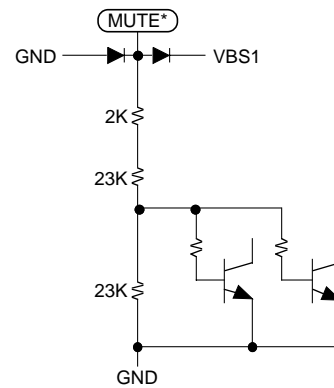

I/O terminal equivalent circuit

(7)CH1,CH2 power I/O terminal equivalent circuit

(VM1(+), VM1(-), VM2(+), VM2(-))

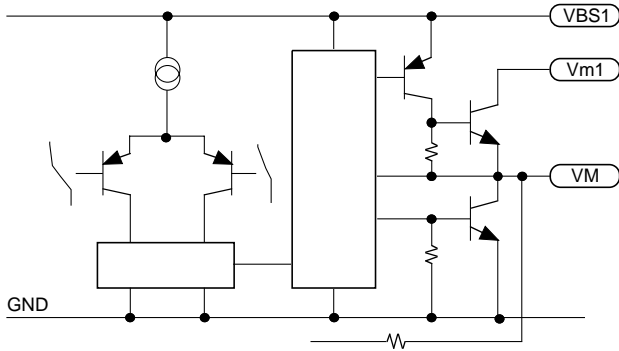

The equivalent circuits of an output stage of power amplifiers are shown in(7) and(8) .

The power supplies of CH1, CH2 are V_{m1} .

And the power supplies of CH3, CH4, CH5 are V_{m2} .

The source side of the power amplifier output stage consists of a PNP and a NPN.

In the case of the CH1 and CH2, the emitta of the PNP is connected to VBS1, and in the case of the CH3, CH4 and CH5, it is connected to VBS2. So the power supplies of the PNP can be adjusted externally.

(8)CH3,CH4,CH5 power amplifier output terminal equivalent circuit

(VM3(+), VM3(-), VM4(+), VM4(-), VM5(+), VM5(-))

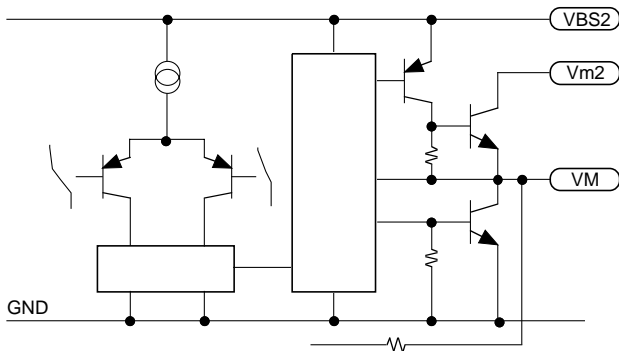

[About bootstrap advantage]

The output stage of the power amplifier consists of the preceding components. If V_{BS}^* is provided with higher voltage input than V_{m}^* (The recommendation voltage is V_{m}^*+1V) externally, the output range can be wider than that of $V_{BS}^*=V_{m}^*$.

Please take advantage of this bootstrap function for the system which has many power supplies. And it is the same with the external bootstrap circuit which provides V_{BS}^* with higher voltage inputs than V_{m}^* .

Also the bootstrap can decrease the saturation voltage at the source side of the power amplifier output stage. Therefore, when the outputs of the power amplifiers which drive motors and actuators are fully swung, the power dissipation of the IC will be decreased.

THERMAL DERATING

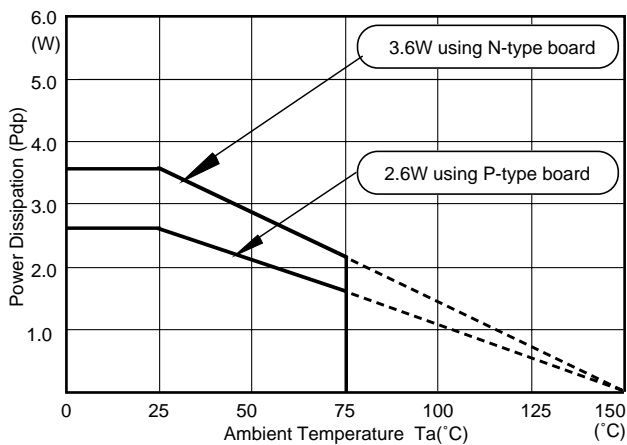

This IC's package is POWER-SSOP, so improving the board on which the IC is mounted enables a large power dissipation without a heat sink.

For example, using an 1 layer glass epoxy resin board, the IC's power dissipation is 2.6W at least. And it comes to 3.6W by using an improved 2 layer board.

The information of the N, P type board is shown in the board information.

APPLICATION CIRCUIT No.1 single input (linear signal) • Direct voltage control

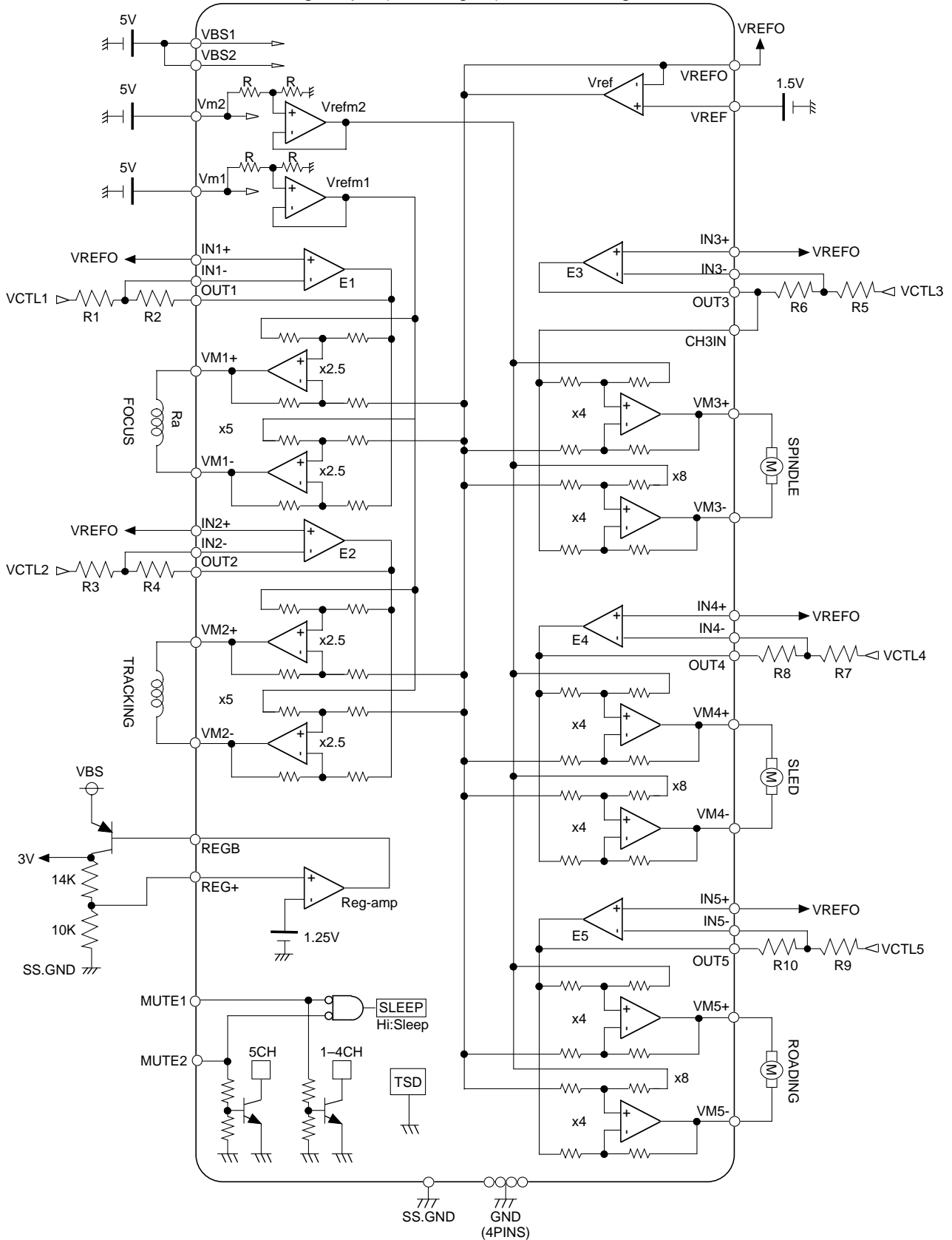

APPLICATION CIRCUIT No.2 Differential PWM input • Direct voltage control (FOCUS, TRACKING, SPINDLE, SLED, ROADING)

