

M57184N-715

UN-INSULATING TYPE DC-DC CONVERTER

DESCRIPTION

M57184N-715 is the un-insulating type DC-DC converter which the rectification voltage of AC200V system can direct input.

A power supply (15V, 350mA, and 5V and 200mA) can be obtained only by attaching a small number of external parts, such as an electrolysis capacitor and a chalk coil.

FEATURE

- Input voltage DC 220 ~ 360V
- Output voltage 15V, 350mA
5V, 200mA

APPLICATION

- Washing machine. Air conditioner. Refrigerator.

OUTLINE DRAWING

Dimensions: mm

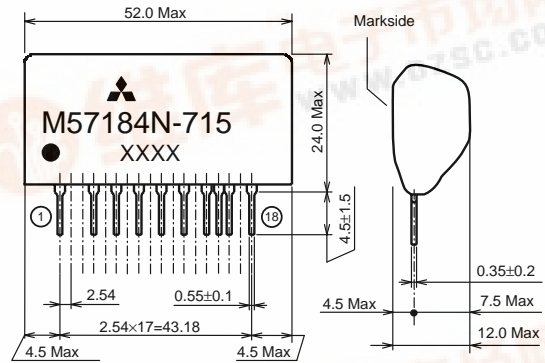

BLOCK DIAGRAM

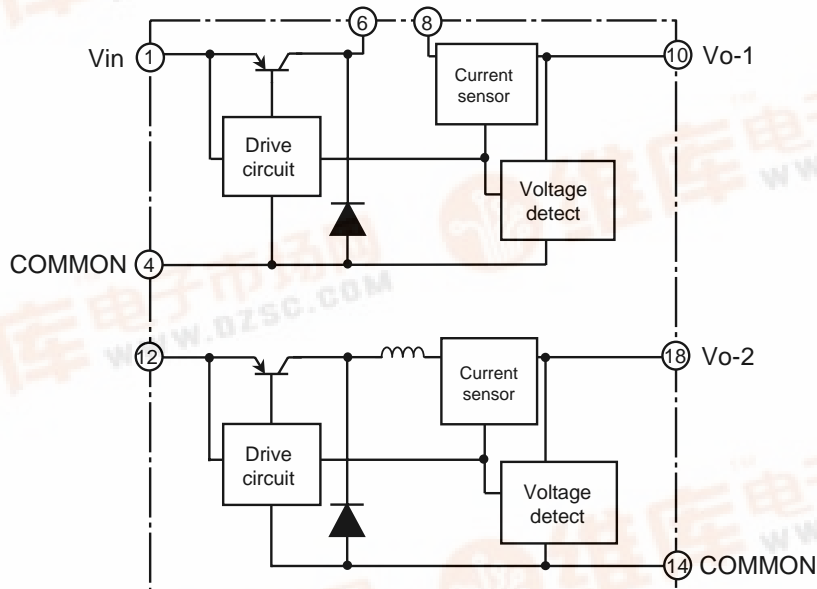

M57184N-715

UN-INSULATING TYPE DC-DC CONVERTER

THE MAXIMUM RATING (Unless otherwise specified, Ta = 25°C)

Symbol	Parameter	Conditions	Ratings	Units
Vin	Input voltage	—	600	V
IL-1	Load current	Vin = 280V, IL-2 = 150mA Notes 1)	370	mA
IL-2	Load current	Vin = 280V, IL-1 = 330mA Notes 1)	250	mA
Pmax	Maximum output power	Vin = 280V	6.3	W
Topr	Operating temperature	There is nothing dew condensation.	-20 ~ +70	°C
Tstg	Storage temperature	There is nothing dew condensation.	-25 ~ +85	°C

Notes 1) A 460mA output is possible for the peak current of IL-1.
Please use each load current in the range which becomes below Pmax.

ELECTRICAL CHARACTERISTICS (Unless otherwise specified, Vin = 280V, Ta = 25°C)

Symbol	Parameter	Test conditions	Ratings			Units
			Min	Typ	Max	
Vin	Input voltage	Recommendation range	220	280	360	V
Vo-1	Output voltage-1	IL-1 = 350mA	14.1	15.0	15.9	V
IL-1	Load current-1	—	0	—	350	mA
Vo-2	Output voltage-2	IL-2 = 200mA	4.7	5.0	5.3	V
IL-2	Load current-2	—	0	—	200	mA
Reg-I-1	Input regulation-1	Vin = 220 ~ 360V, IL-1 = 350mA	—	60	160	mV
Reg-I-2	Input regulation-2	Vin = 220 ~ 360V, IL-2 = 200mA	—	60	160	mV
Reg-L-1	Load regulation-1	IL-1 = 0 ~ 350mA	—	80	200	mV
Reg-L-2	Load regulation-2	IL-2 = 0 ~ 200mA	—	80	200	mV
η	Efficiency	IL-1 = 350mA, IL-2 = 200mA	65	72	—	%
Vp-p	Output ripple voltage	IL-1 = 350mA, IL-2 = 200mA Notes 2)	—	80	200	mVp-p

Notes 2) A spike noise does not contain in output ripple voltage

CIRCUIT DIAGRAM

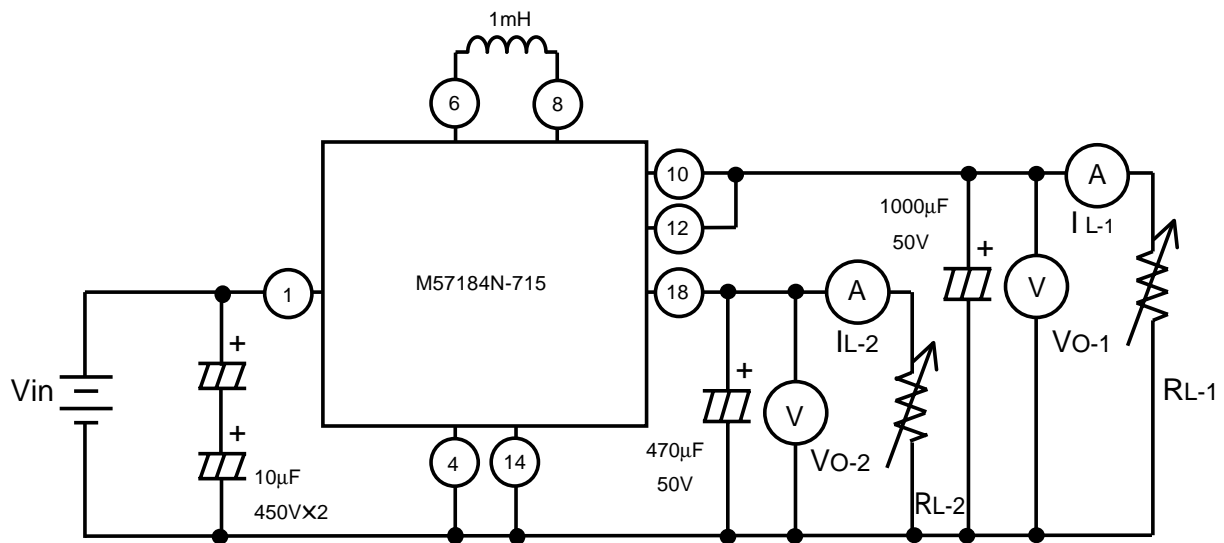

M57184N-715

UN-INSULATING TYPE DC-DC CONVERTER

TYPICAL CHARACTERISTICS

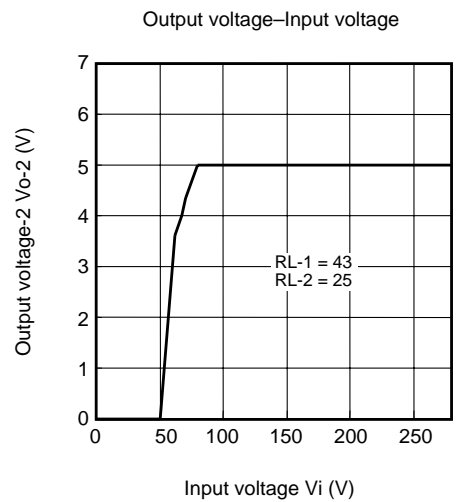
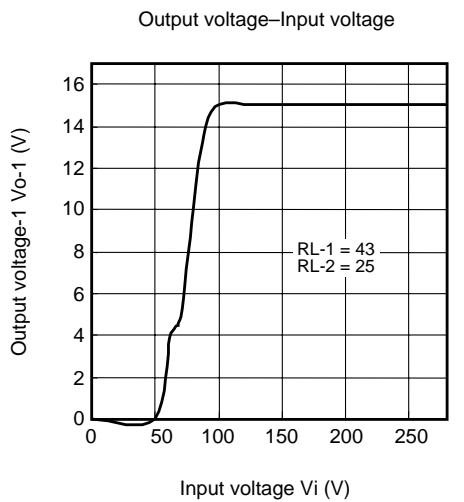
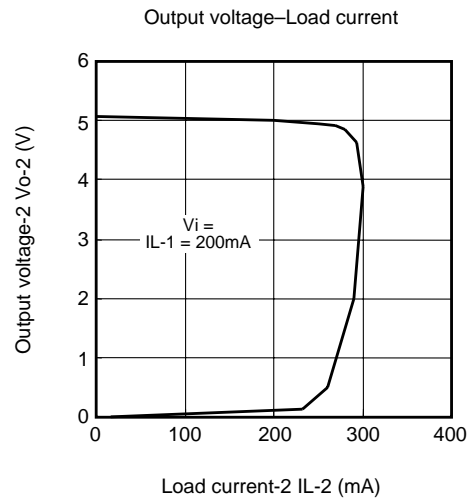
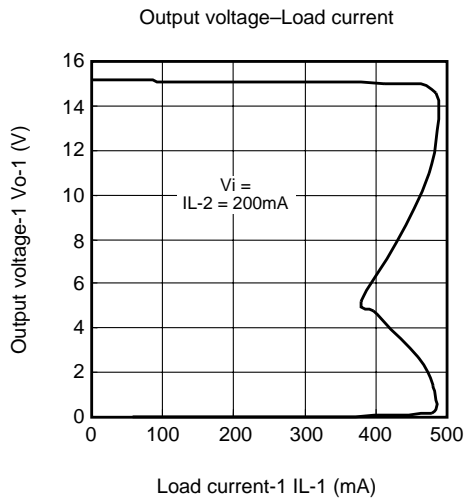
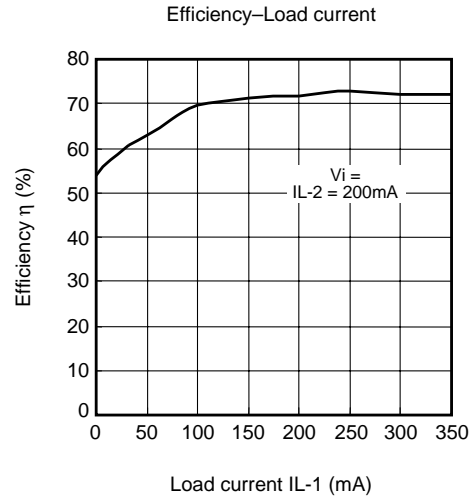
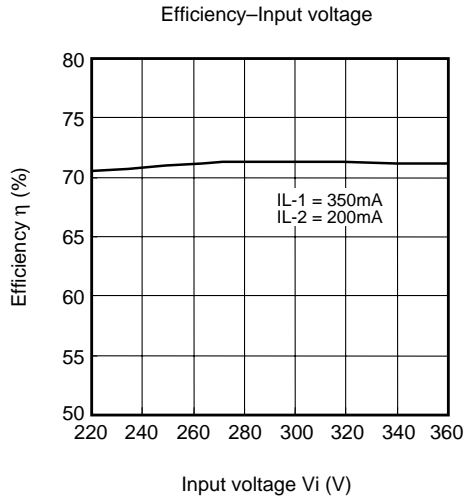

M57184N-715

UN-INSULATING TYPE DC-DC CONVERTER

